

Assembly Instructions

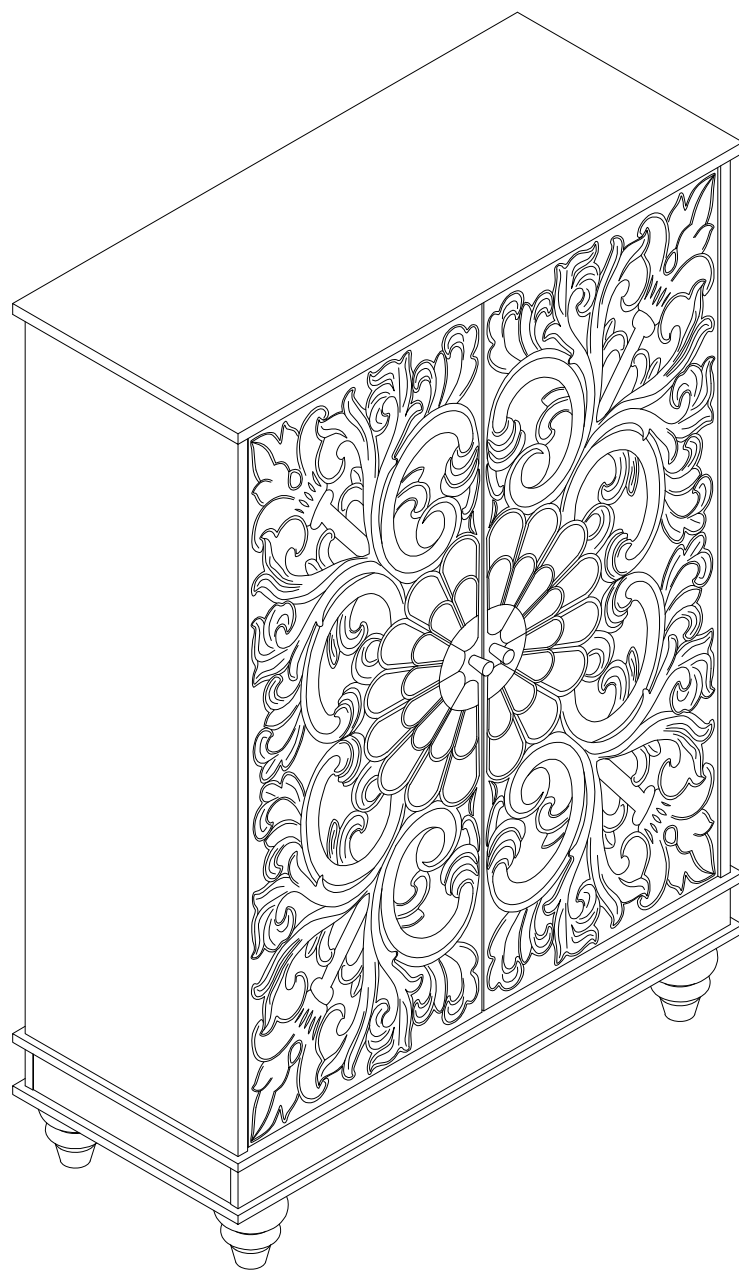

Before Assembly

Tips Before Your Start:

- Remove all wrapping material, including staples & packing straps before you start to assemble.
- DO NOT tighten all screws and bolts until the assembly is completely assembled.
- Keep all hardware parts out of reach of children.

QUICKFIT

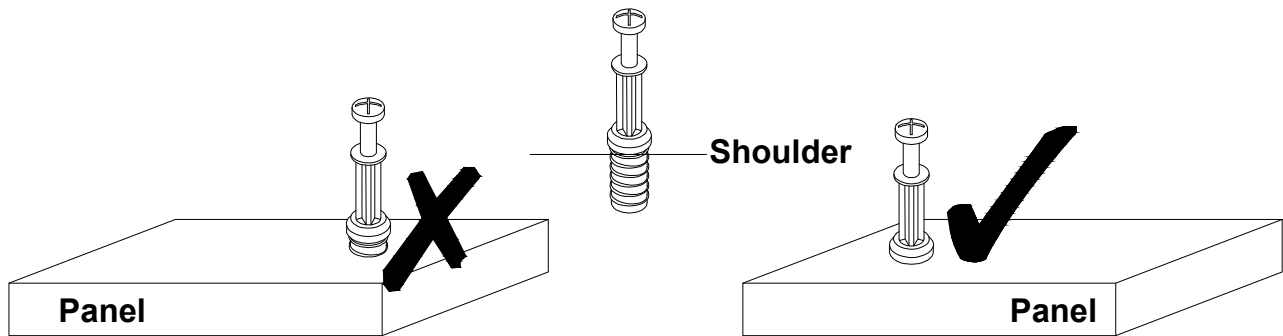

Tighten quickfit until shoulder is flush with panel. Do not overtighten or undertighten.

CAM LOCK

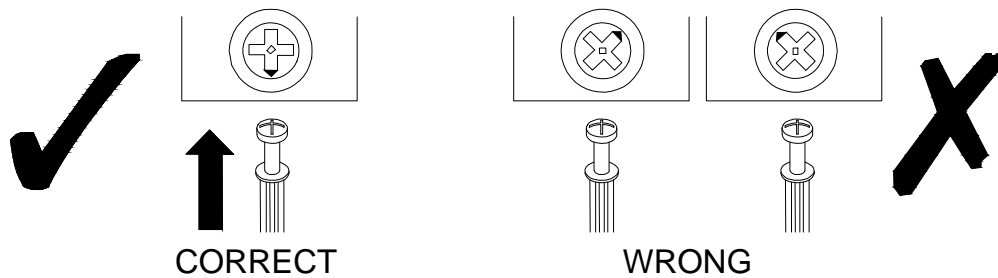

When fitting a cam lock, ensure the starting position is correct before inserting the connecting QUI CKFIT





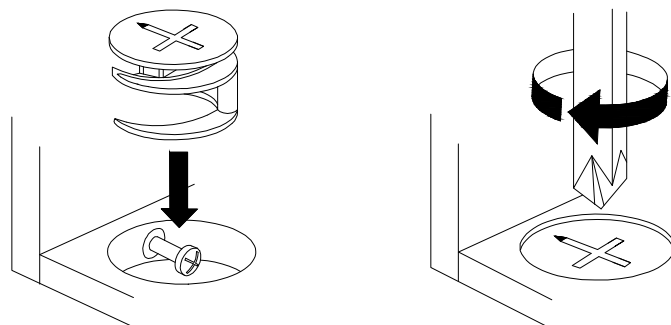



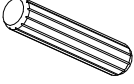
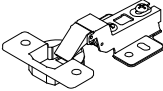

Quickfit head should be in the centre of the cam lock when the two panels are joined.

Cam lock should be inserted before quickfit.

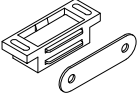

Turn cam lock clockwise to tighten.

Part List

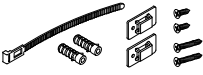
<p>No. A Quantity: 28 Pcs Cam Lock Dowel 8*28mm</p> 	<p>No. B Quantity: 28 Pcs Cam 15</p> 	<p>No. C Quantity: 28 Pcs Sticker Ø20</p> 	<p>No. D Quantity: 12 Pcs Dowel 8*30mm</p> 
<p>No. E Quantity: 4 Pcs Hinge</p> 	<p>No. F Quantity: 2 Pcs Handle</p> 	<p>No. G Quantity: 32 Pcs Screw M3.5*14mm</p> 	<p>No. H Quantity: 2 Pcs Screw M4*25mm</p> 
<p>No. I Quantity: 4 Pcs Slip Mat Ø20</p> 	<p>No. J Quantity: 2 Sets Magnetic Door Catcher</p> 	<p>No. K Quantity: 8 Pcs Shelf Support M5*15mm</p> 	<p>No. L Quantity: 8 Pcs Screw M6*40mm</p> 
<p>No. M Quantity: 1 Pcs Allen Key 4#</p> 	<p>No. N Quantity: 12 Sets Plastic Wedge</p> 	<p>No. O Quantity: 1 Sets Anti-falling Parts</p> 	

Product structure

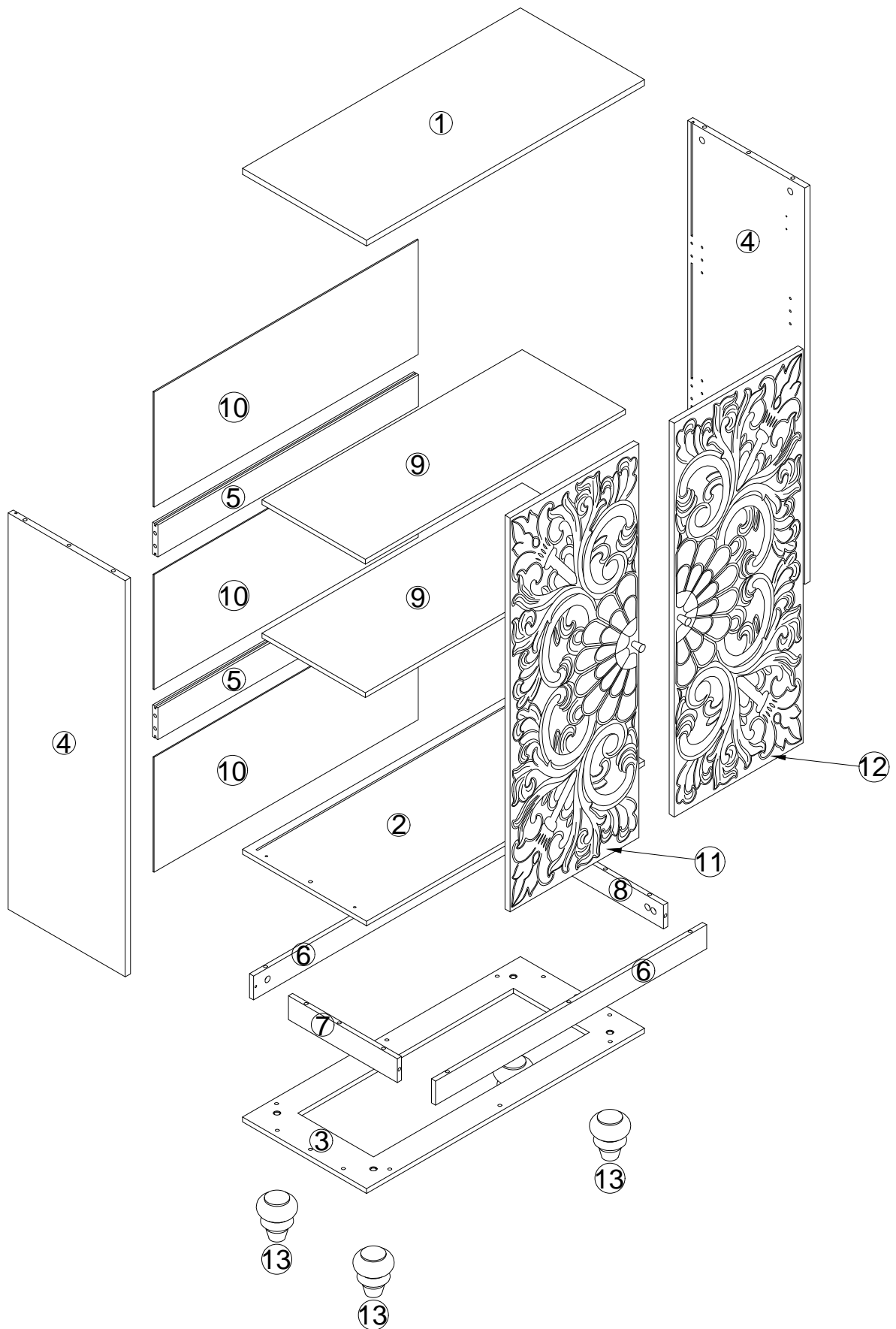

STEP 1

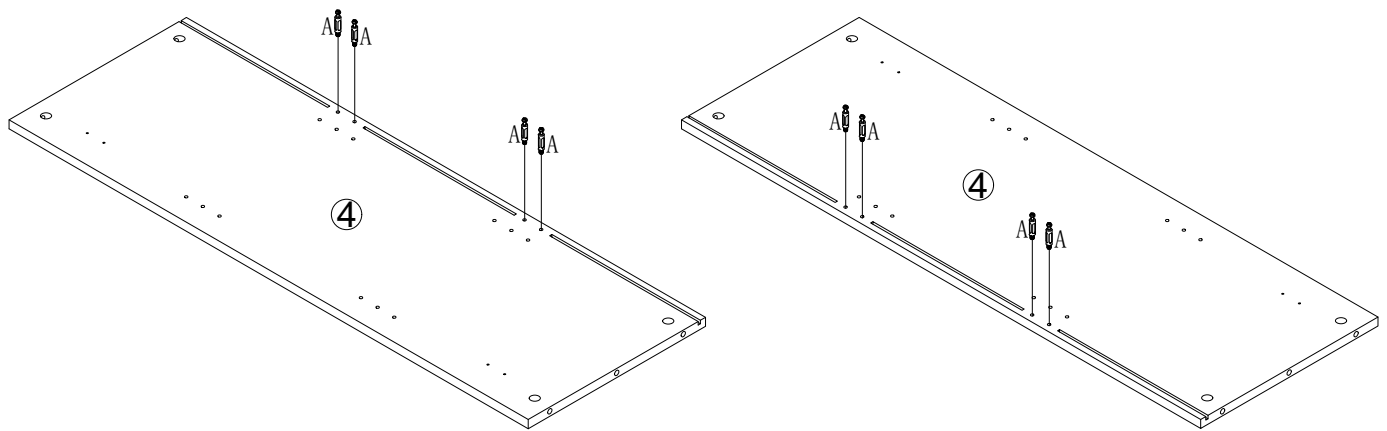

No. A
Quantity: 8 Pcs
8*28 mm



STEP 2

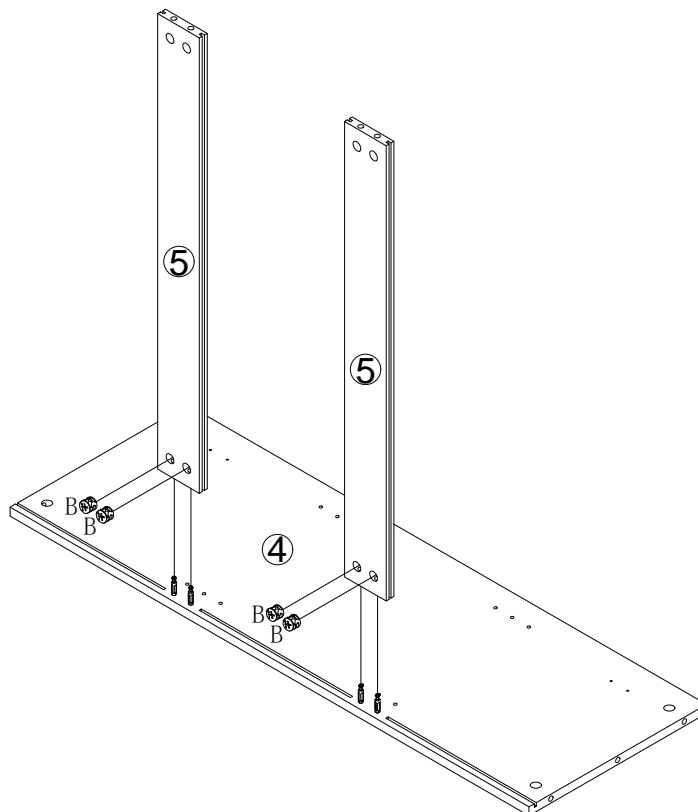

No. B
Quantity: 4 Pcs
Ø15



STEP 3

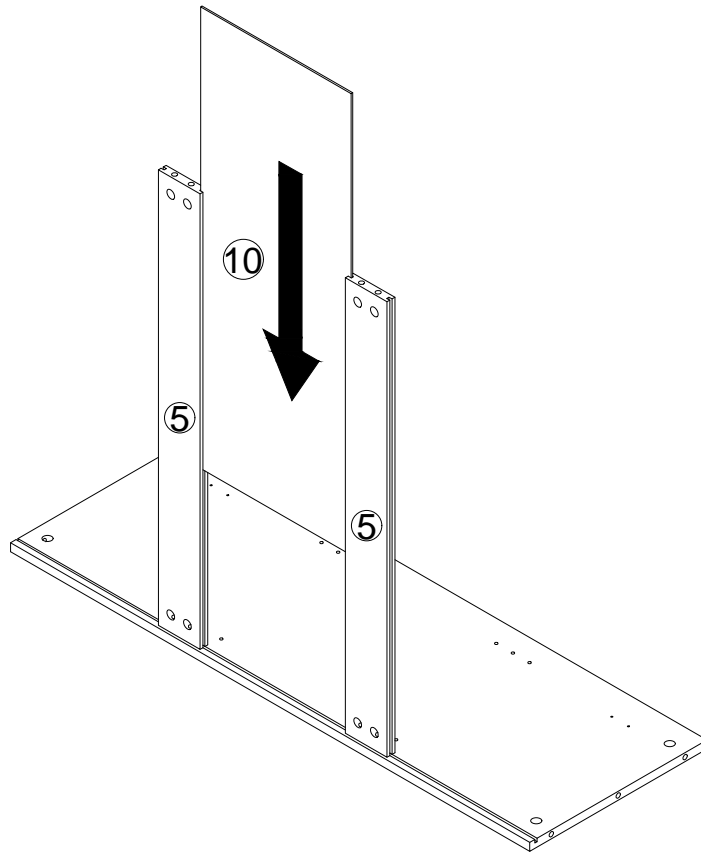

STEP 4

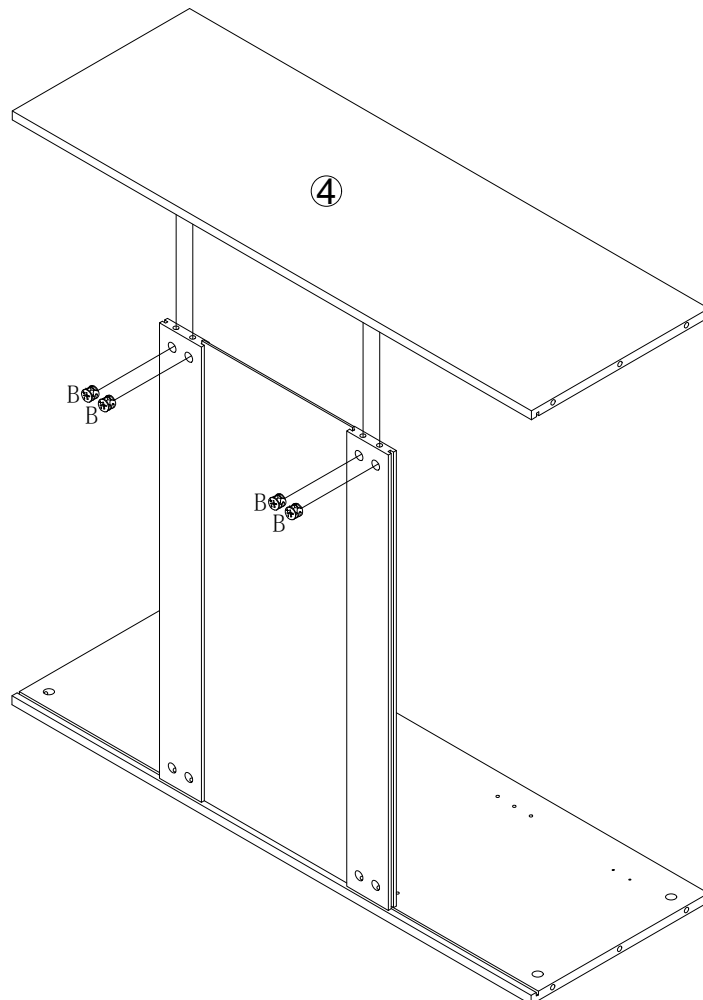

No. B
Quantity: 4 Pcs
Ø15



STEP 5

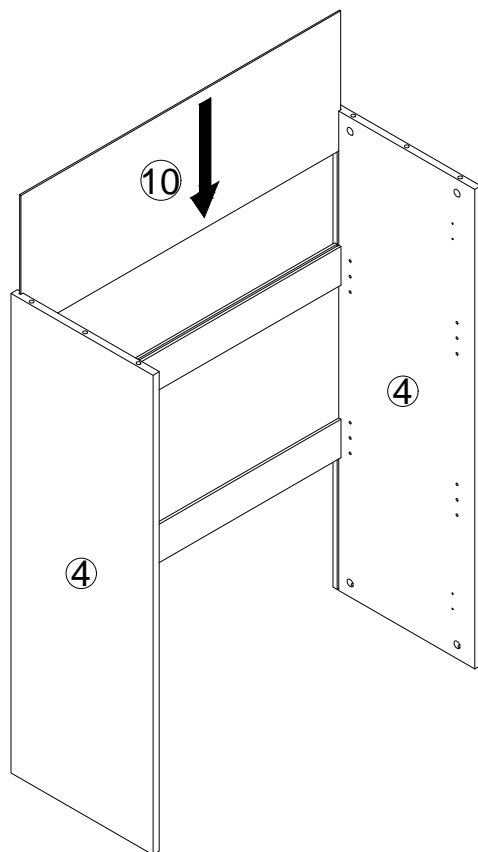

STEP 6

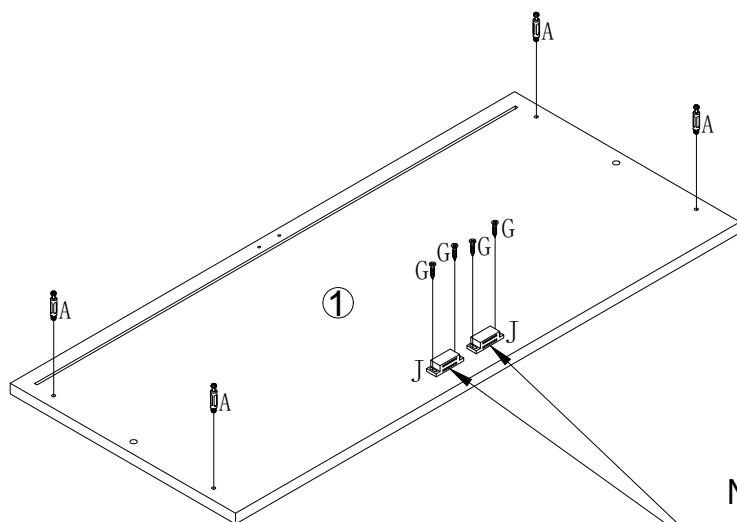

Note: Assemble with the magnetic side facing outwards.

No. A
Quantity: 4 Pcs
8*28 mm



No. G
Quantity: 4 Pcs
M3.5*14mm



No. J
Quantity: 2 Pcs

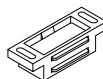

STEP 7

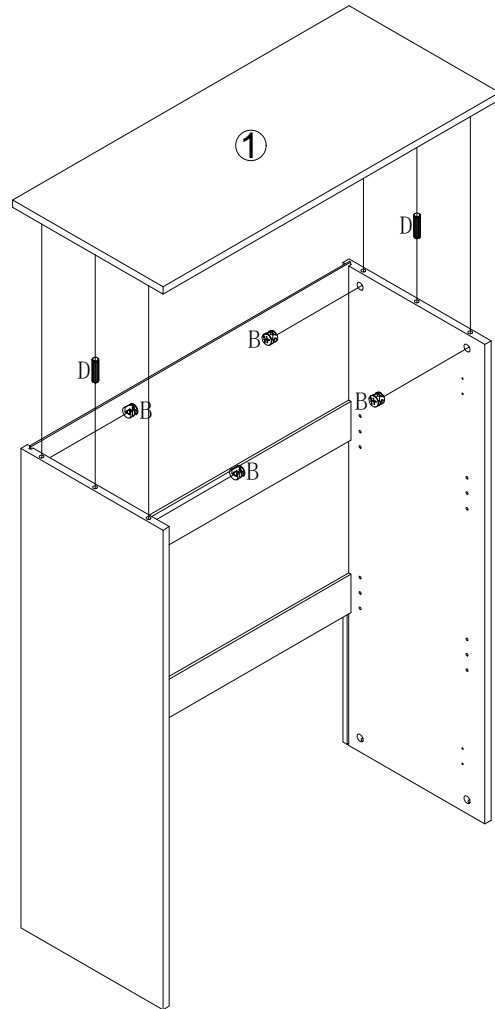

No. B
Quantity: 4 Pcs
Ø15



No. D
Quantity: 2 Pcs
8*30mm

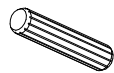

STEP 8

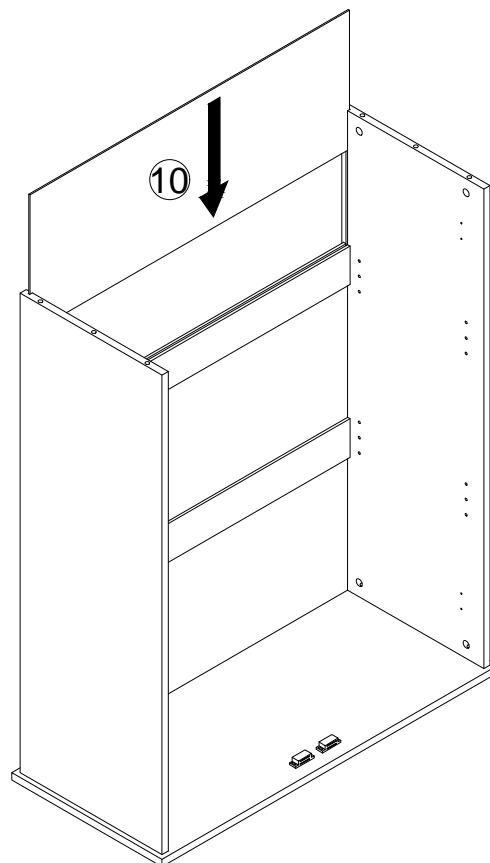

STEP 9

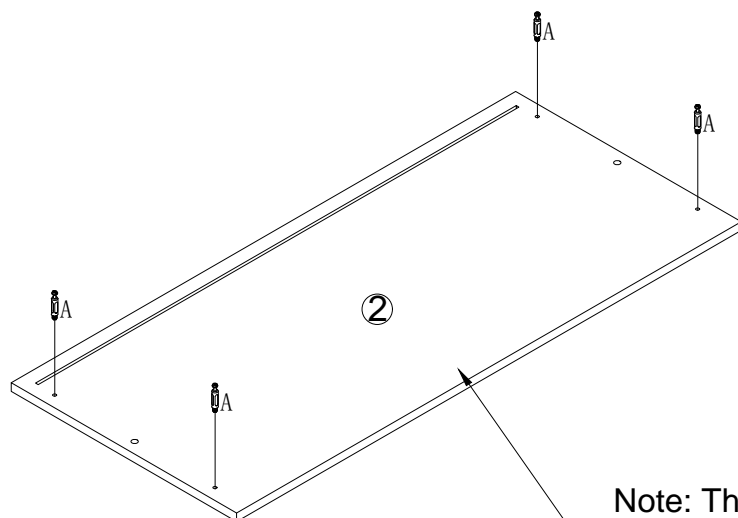

Note: This block has holes on both sides, please pay attention to the difference.

No. A

Quantity: 4 Pcs

8*28 mm



STEP 10

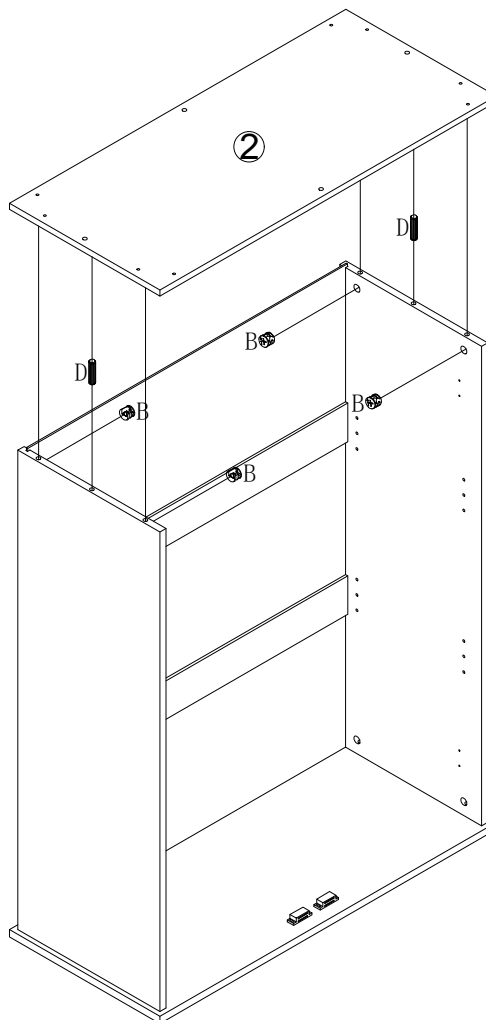

No. B

Quantity: 4 Pcs

Ø15



No. D

Quantity: 2 Pcs

8*30mm

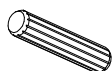

STEP 11

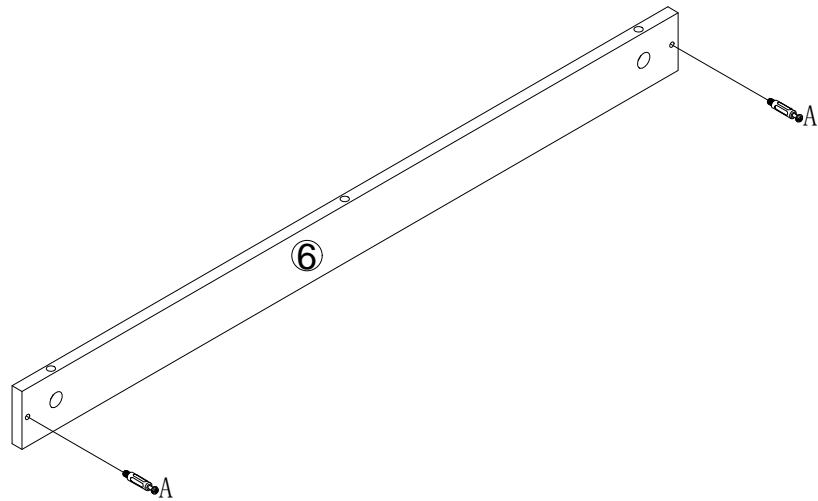

No. A
Quantity: 4 Pcs
8*28 mm



x2

STEP 12

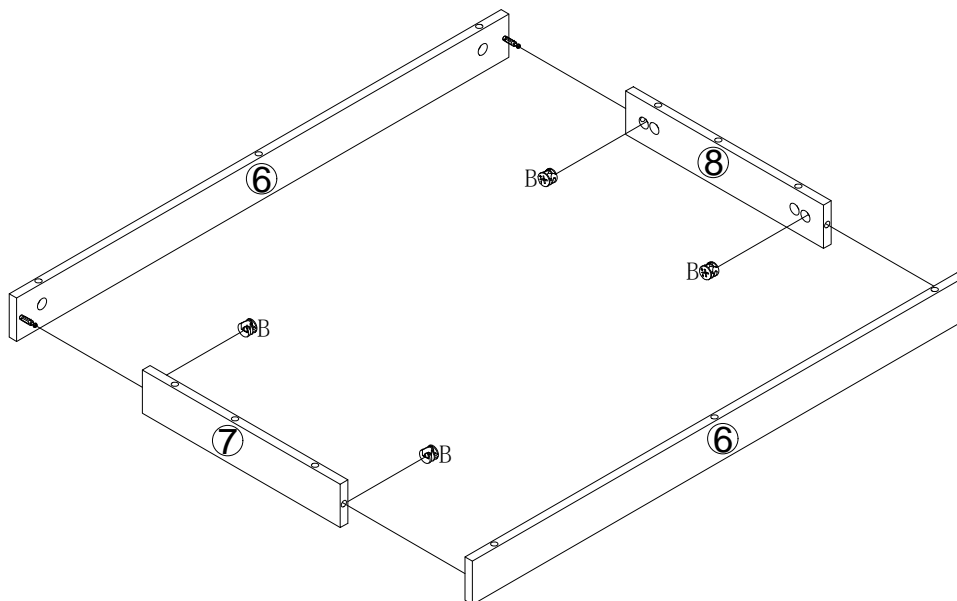

No. B
Quantity: 4 Pcs
Ø15



STEP 13

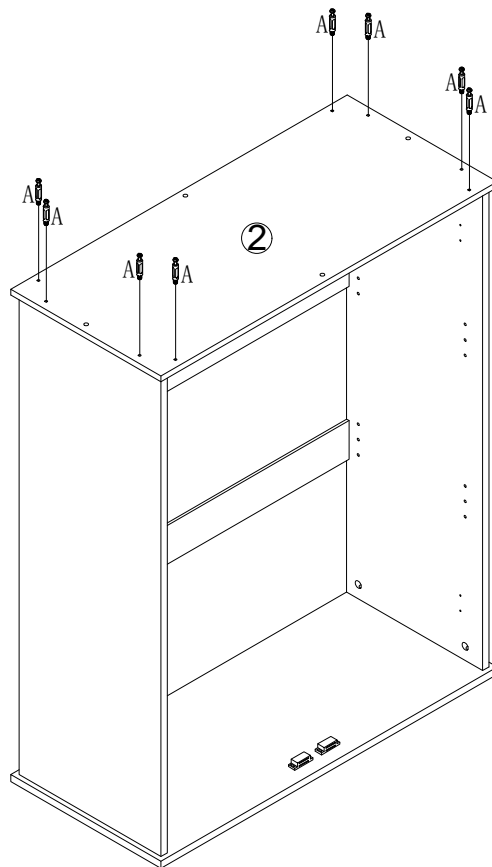

No. A
Quantity: 8 Pcs
8*28 mm



STEP 14

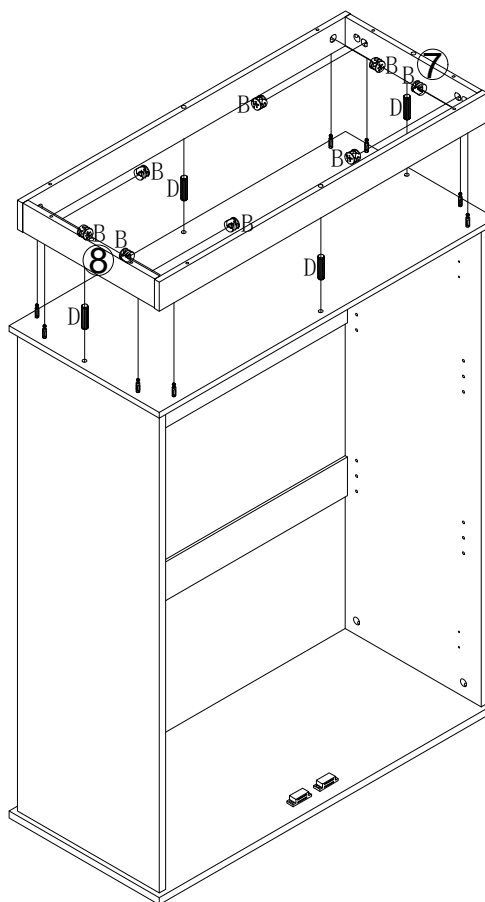

No. B
Quantity: 8 Pcs
Ø15



No. D
Quantity: 4 Pcs
8*30mm

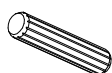

STEP 15

No. D
Quantity: 4 Pcs
8*30mm

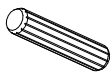

No. L
Quantity: 8 Pcs
M6*40mm



No. M
Quantity: 1 Pcs
4#

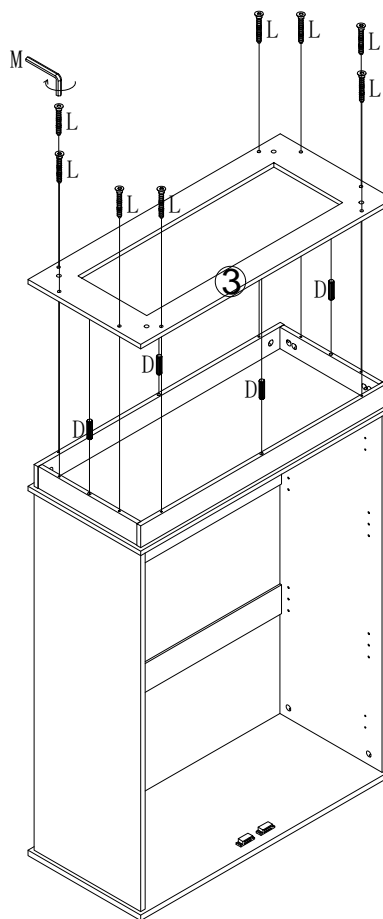

STEP 16

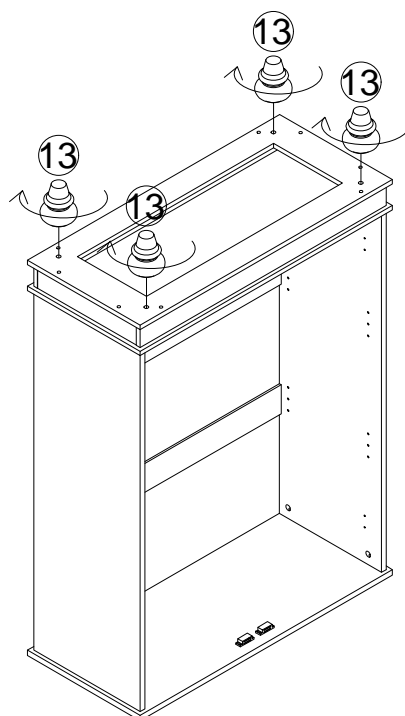

STEP 17

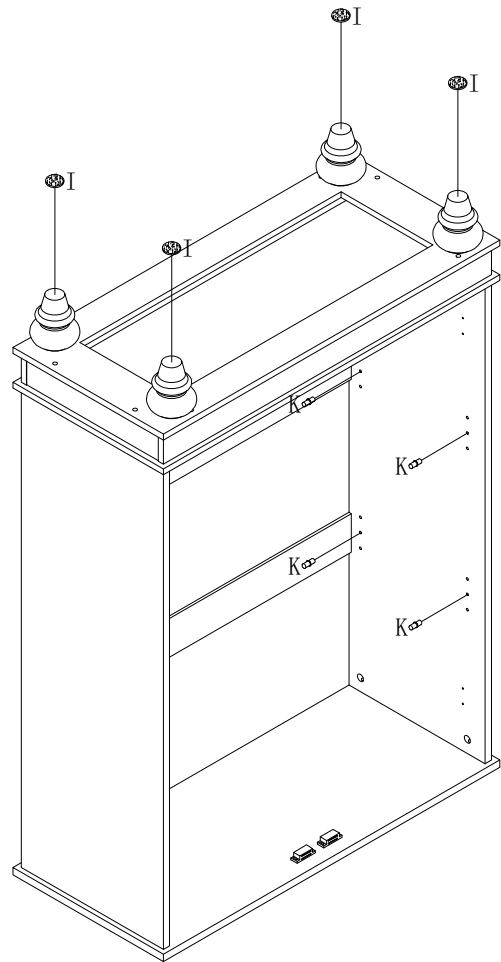

No. I
Quantity: 4 Pcs



No. K
Quantity: 8 Pcs
M5*15mm



STEP 18

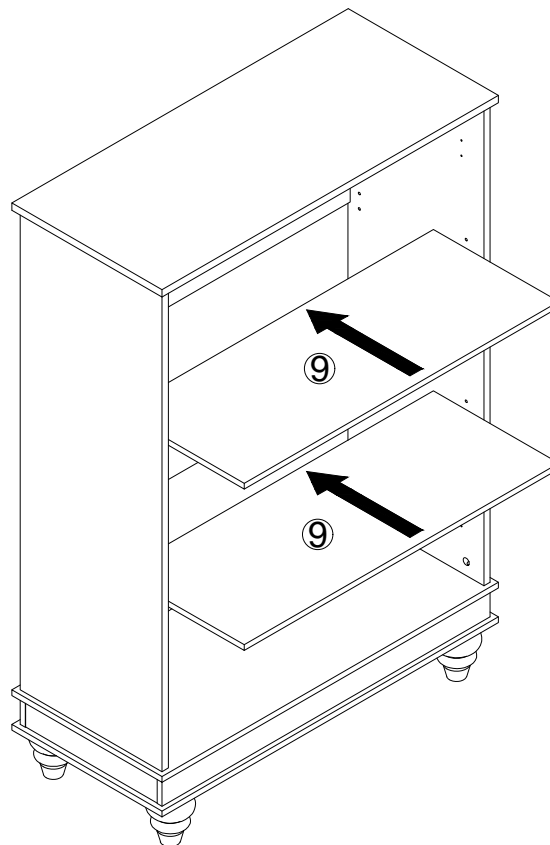

STEP 19

No. E
Quantity: 4 Pcs

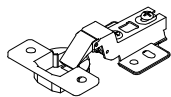

No. F
Quantity: 2 Pcs



No. G
Quantity: 12 Pcs
M3.5*14mm



No. H
Quantity: 2 Pcs
M4*25mm



No. J
Quantity: 2 Pcs

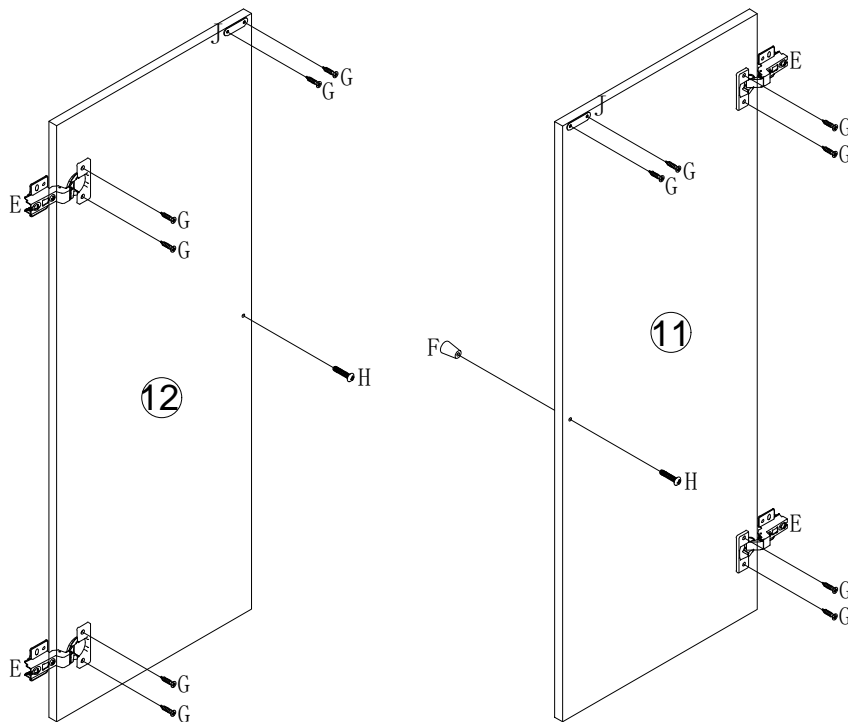

STEP 20

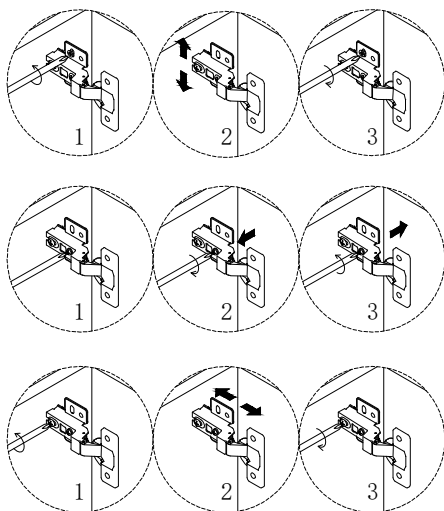

No. G
Quantity: 16 Pcs
M3.5*14mm

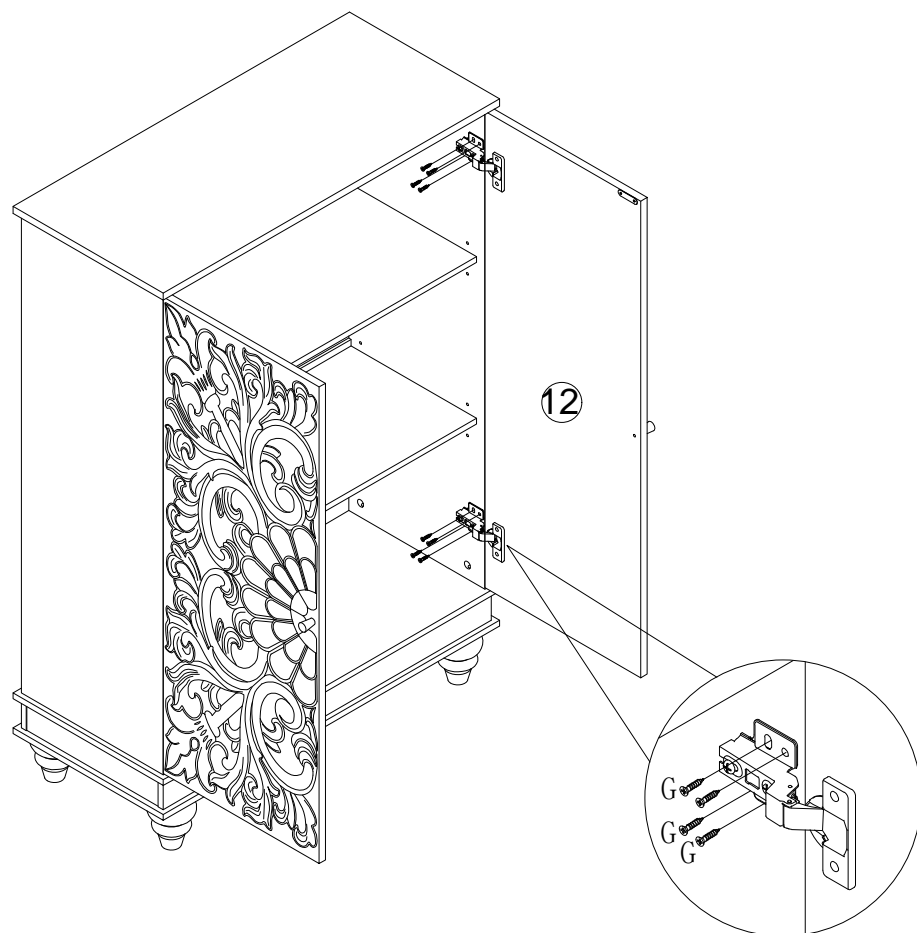

STEP 21

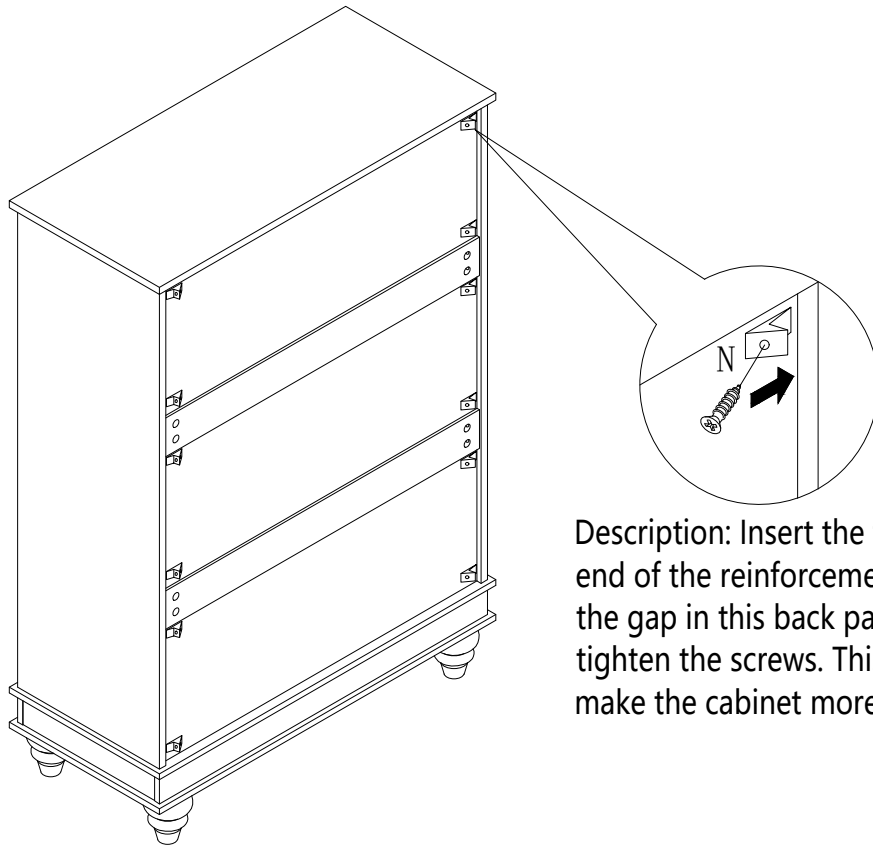

Description: Insert the thinner end of the reinforcement into the gap in this back panel, then tighten the screws. This will make the cabinet more stable.

No. N
Quantity: 12 Sets

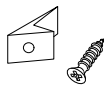

STEP 22

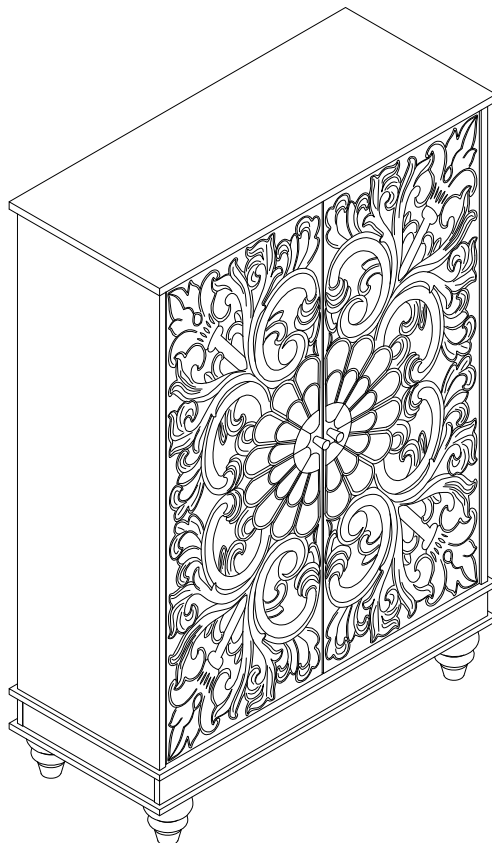

STEP 23

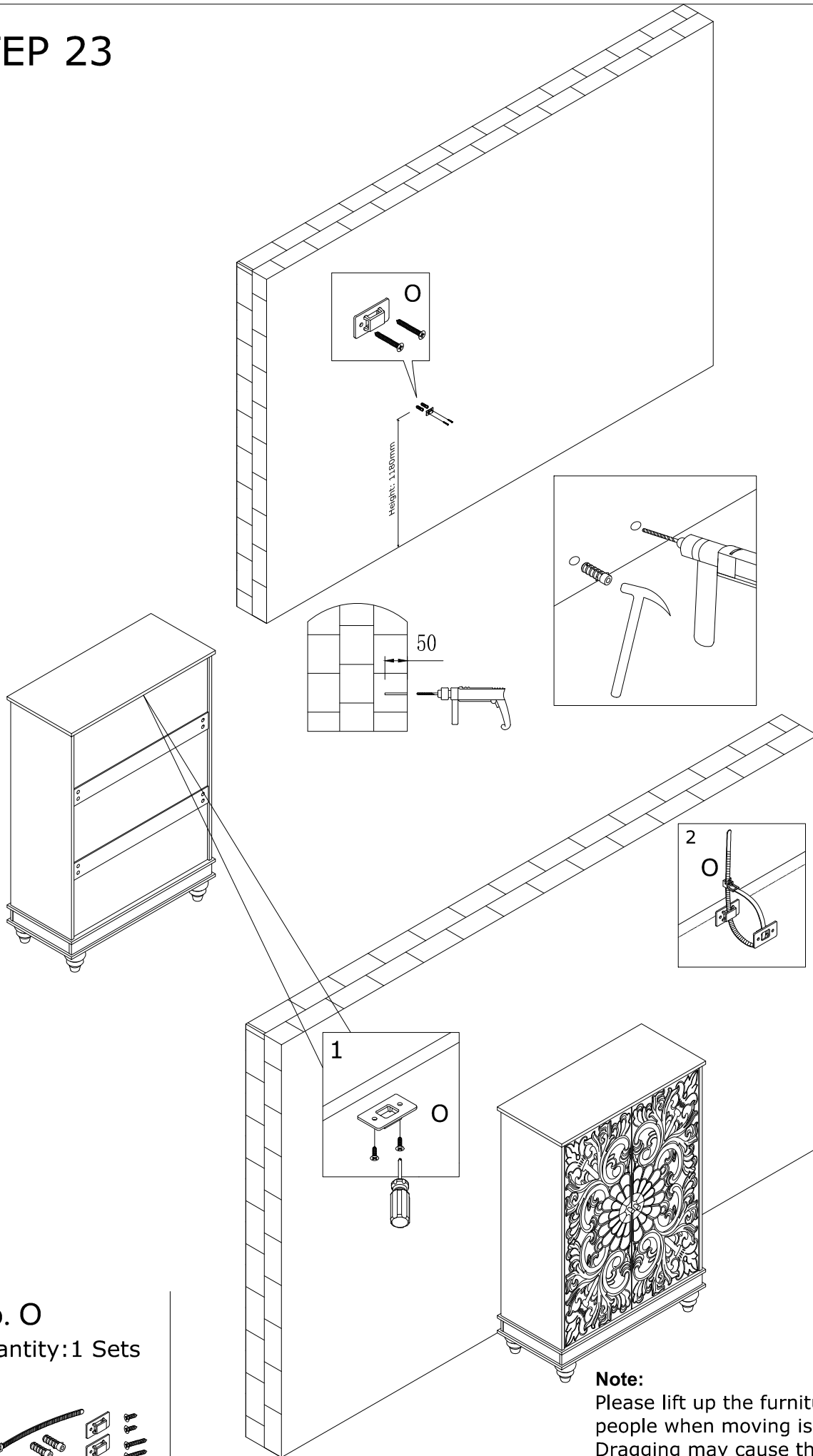

No. O
Quantity: 1 Sets

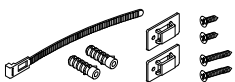

Note:
Please lift up the furniture by two people when moving is needed.
Dragging may cause the legs failure.