

EN_IMPORTANT, RETAIN FOR FUTURE REFERENCE: READ CAREFULLY.

USING CAM LOCK AND QUICKFIT

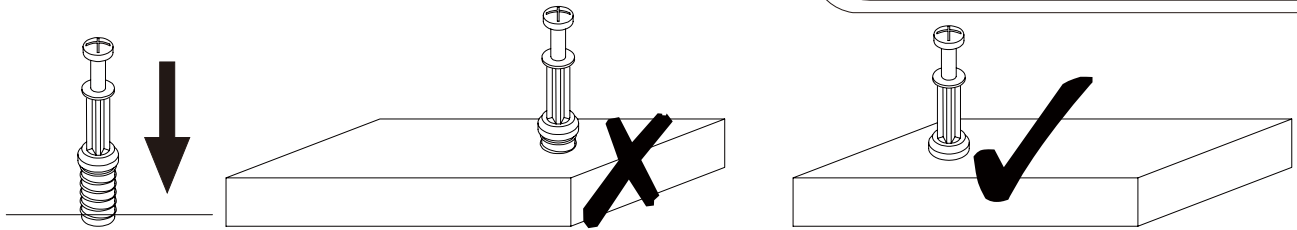

EN_QUICKFIT: Tighten quickfit until shoulder is flush with panel. Do not overtighten or undertighten.

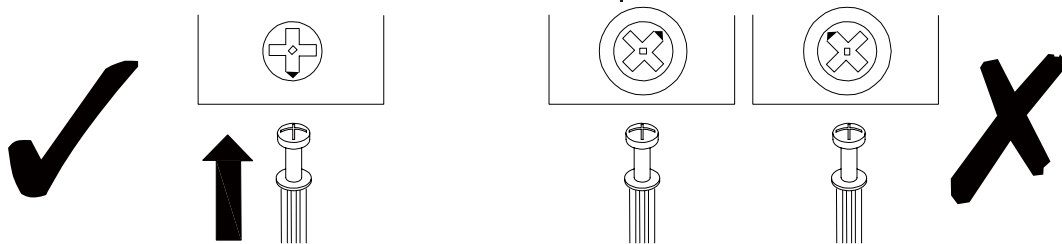

EN_CAM LOCK: When fitting cam lock, ensure starting position is correct before you insert connecting quickfit.

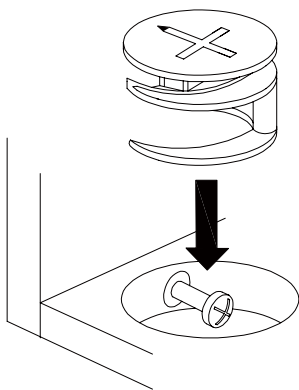



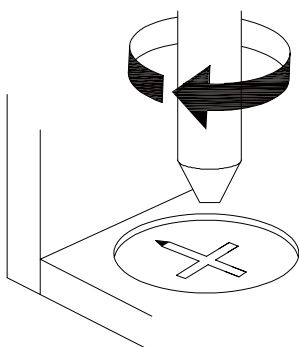

EN_Quickfit head should be in the centre of the cam lock when the two panels are joined.
Cam lock should be inserted before quickfit.



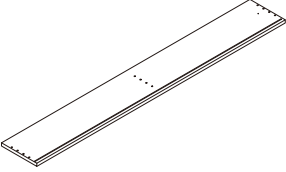
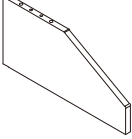
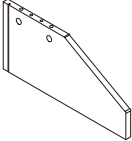
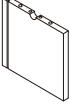
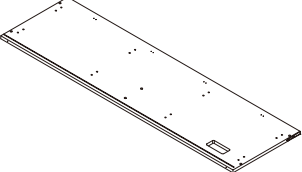
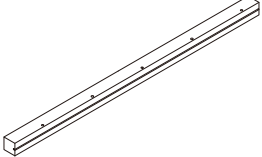
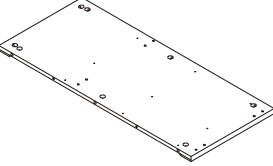
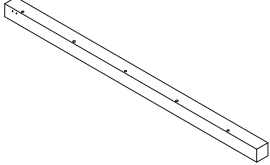
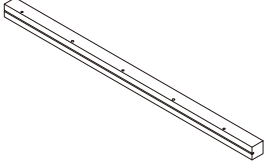
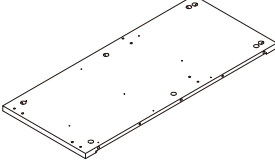

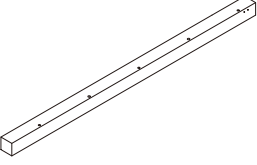
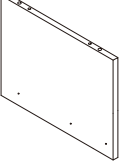
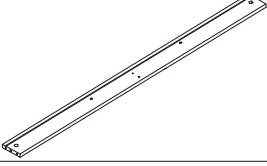
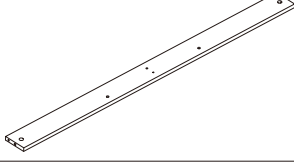
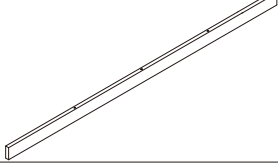
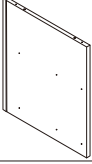
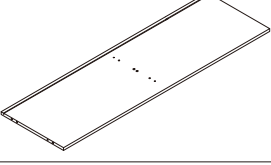





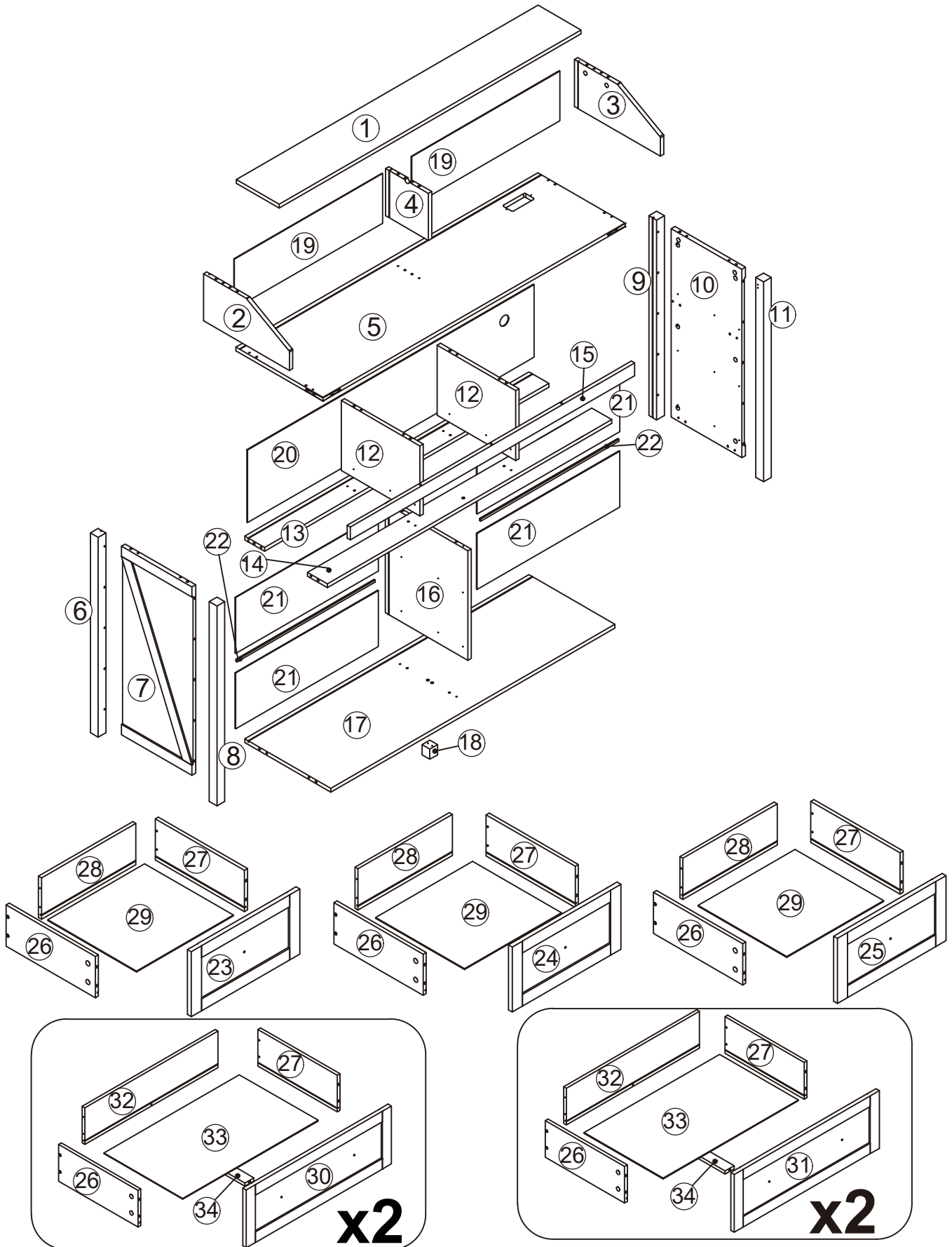

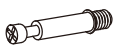



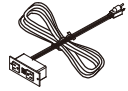





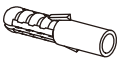

EN_Turn cam lock clockwise to tighten.

PACKING DELALS

NO.	PARTS	QTY	SPARE
①		x1	
②		x1	
③		x1	
④		x1	
⑤		x1	
⑥		x1	
⑦		x1	
⑧		x1	
⑨		x1	
⑩		x1	

NO.	PARTS	QTY	SPARE
⑪		x1	
⑫		x2	
⑬		x1	
⑭		x1	
⑮		x1	
⑯		x1	
⑰		x1	
⑱		x1	
⑲		x2	
⑳		x1	



A x66(+2)  Ø6x35mm	B x66(+2)  Ø15x10mm	C x47(+2)  Ø6x30mm	D x50(+2)  Ø4x35mm	E x108(+3)  Ø3.5x12mm	F x1 
G x2  Ø3x12mm	H x6 	I x11 I-1  I-2 	J x1 	K x4 	L x1 L-1  L-2 
M x1 	N x2 	O x2 	P x2  Ø4x14mm	Q x30(+2) 	R x30(+2)  Ø3x16mm
S x6  Ø20mm	CL x7  L350mm	CR x7  L350mm	DL x7  L350mm	DR x7  L350mm	

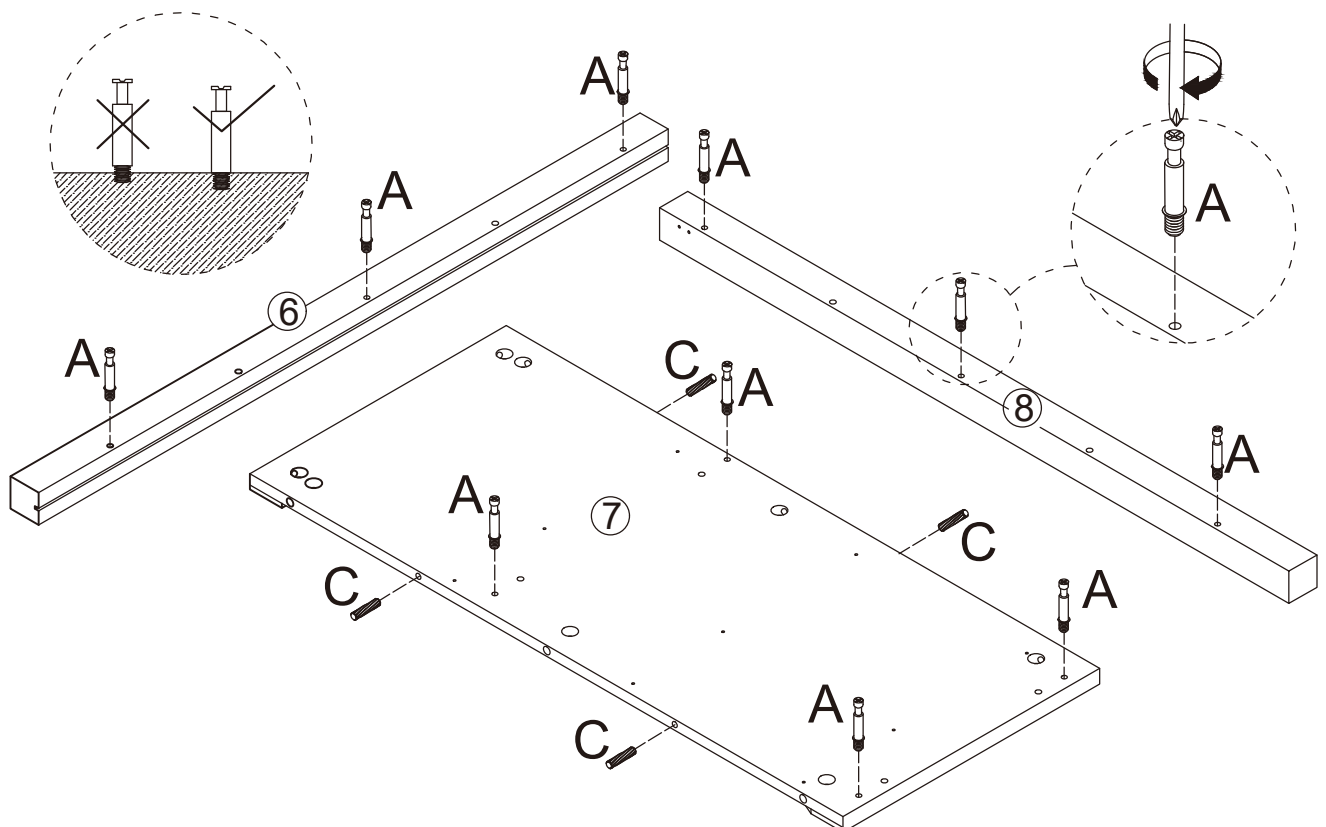
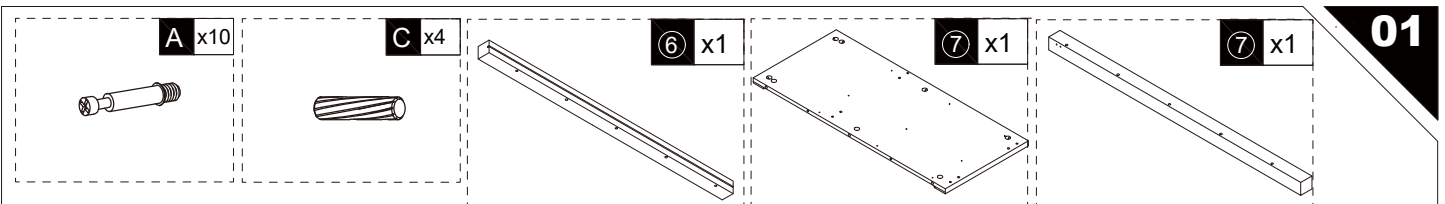

B x6

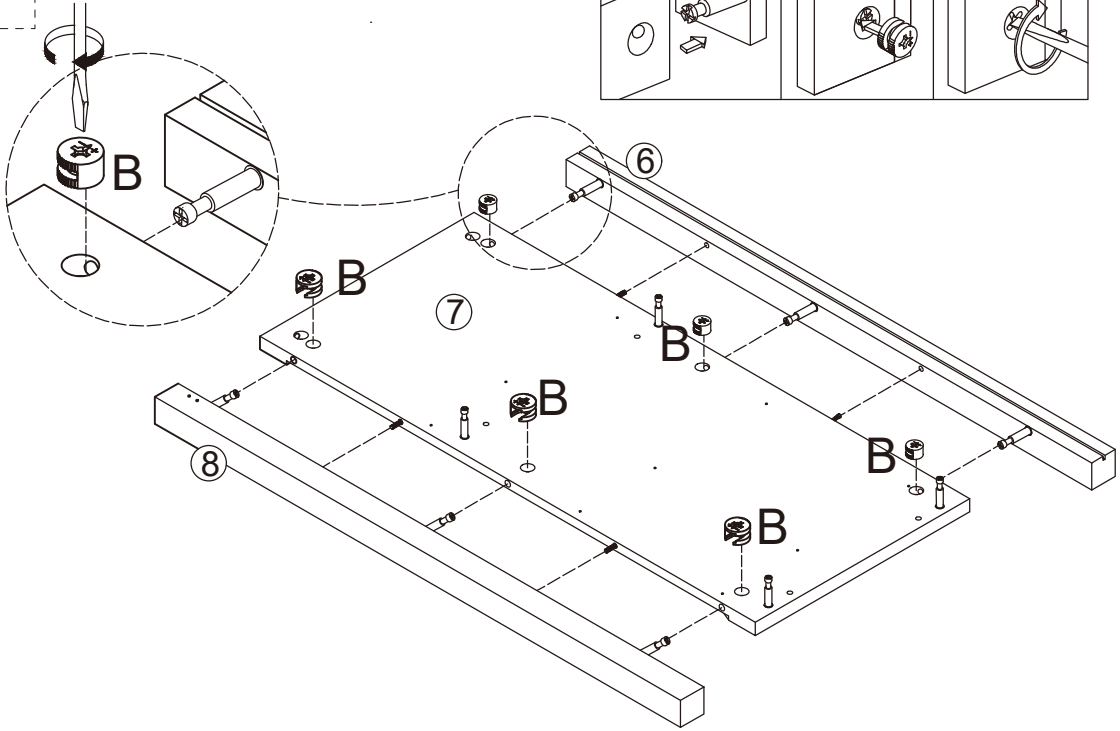
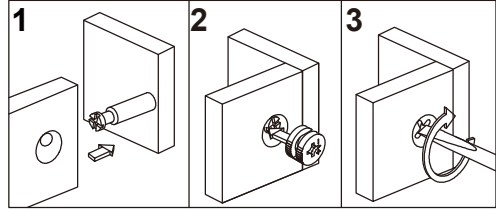

E x9

CL x3

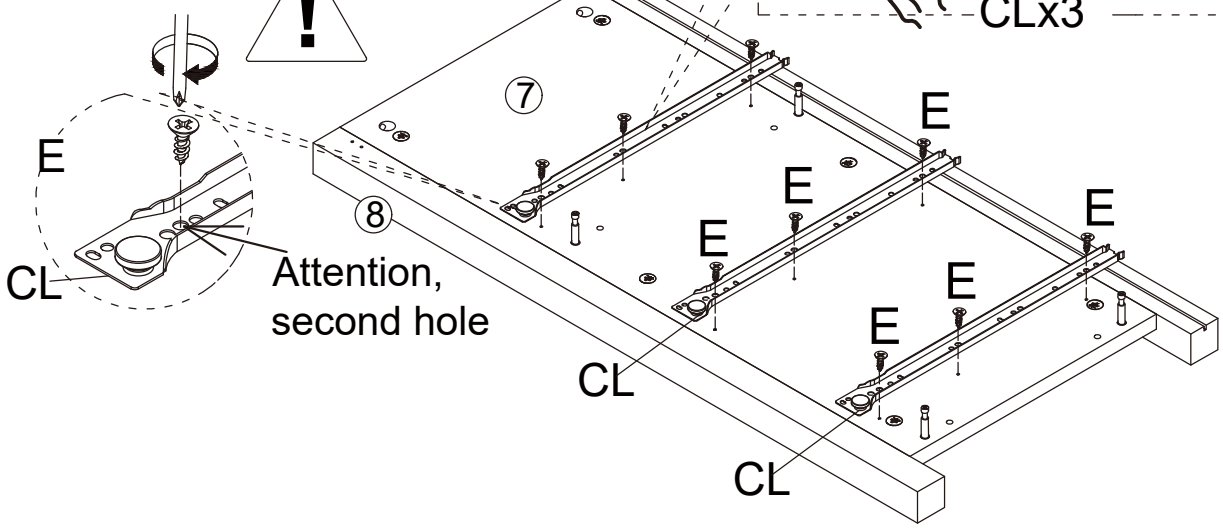
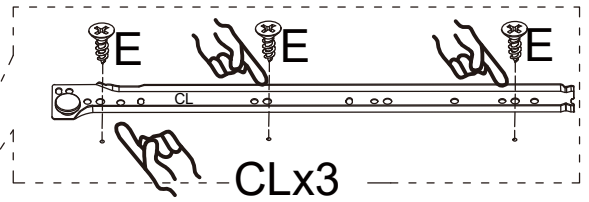
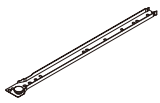

A x10

C x4

9 x1

10 x1

11 x1

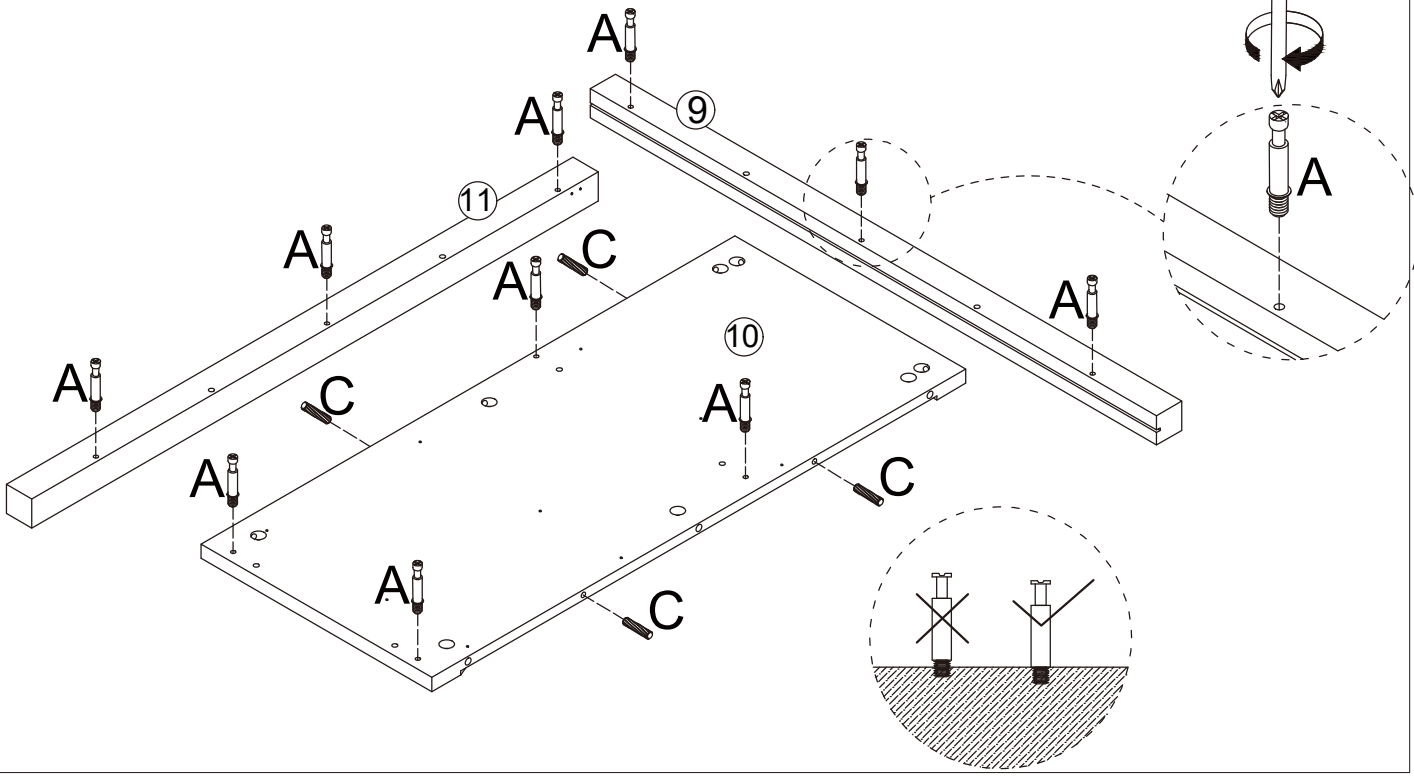
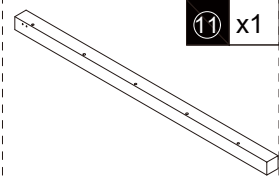
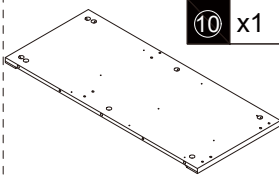
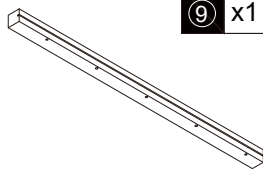
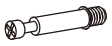

B x6

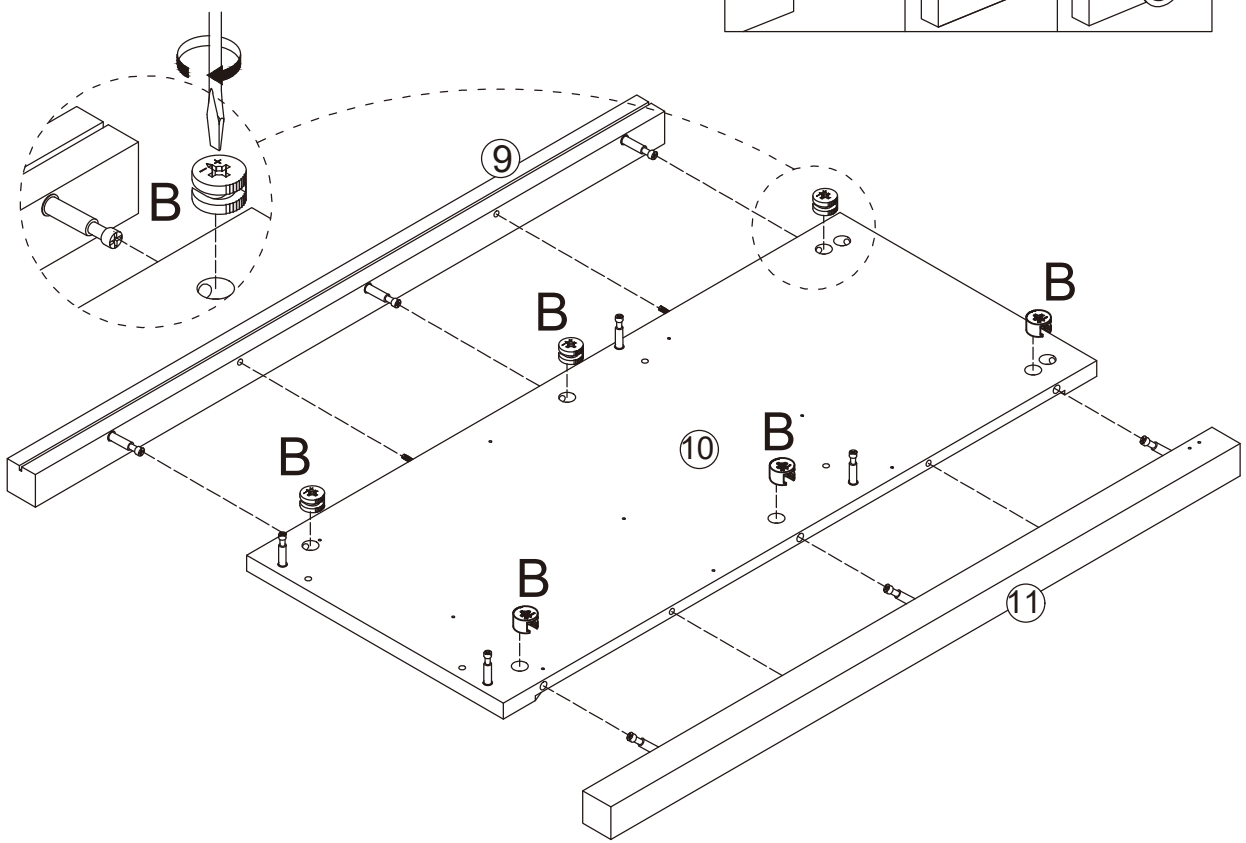
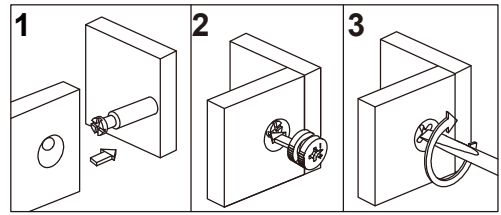

E x9

CRx3

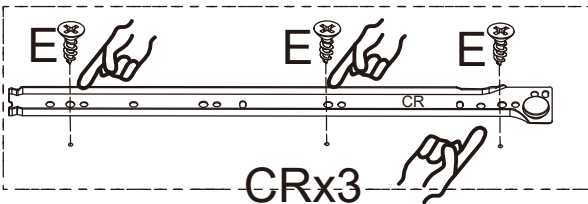
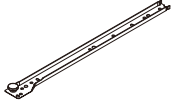

CRx3

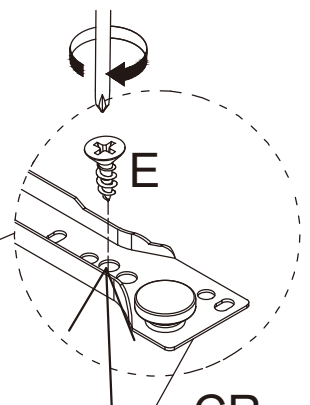
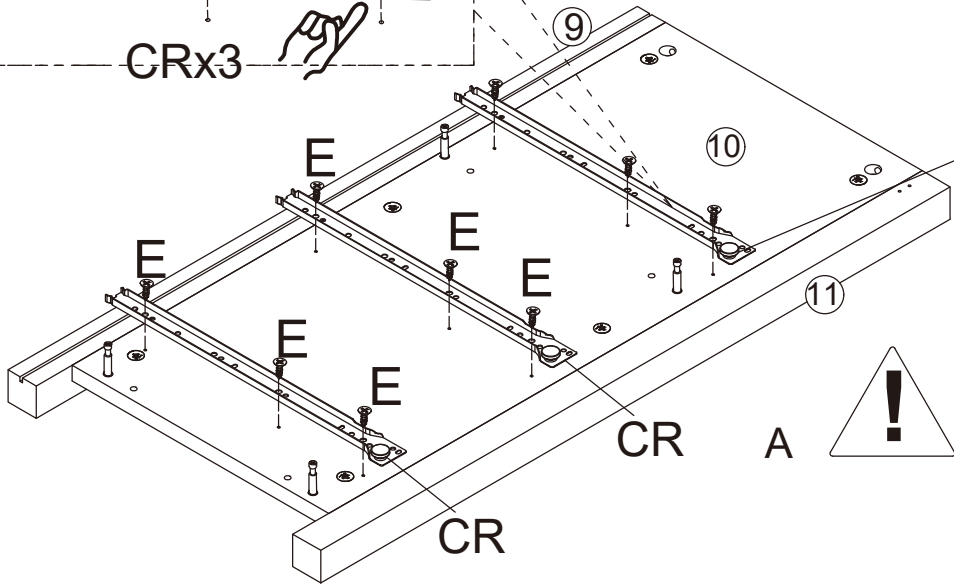

Attention, CR second hole

E x12

CLx2

CRx2

12 x2

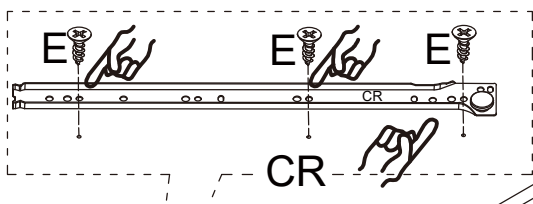
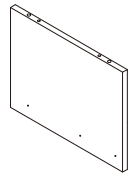
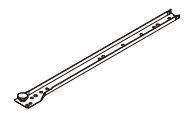
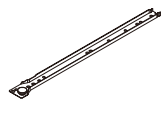

CR

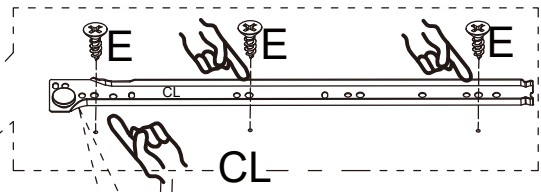

CL

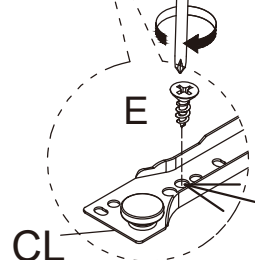
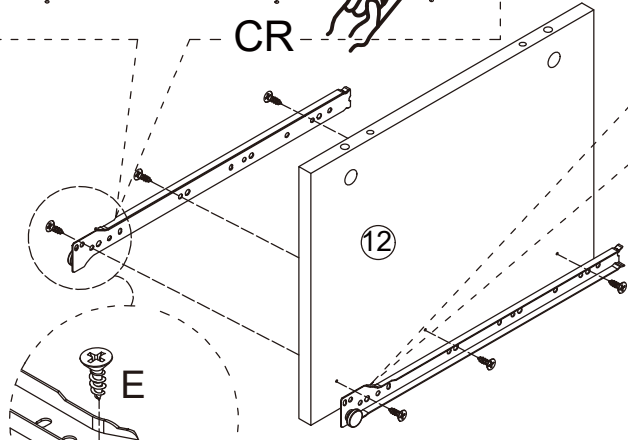

Attention, second hole

Attention, first hole !

x2

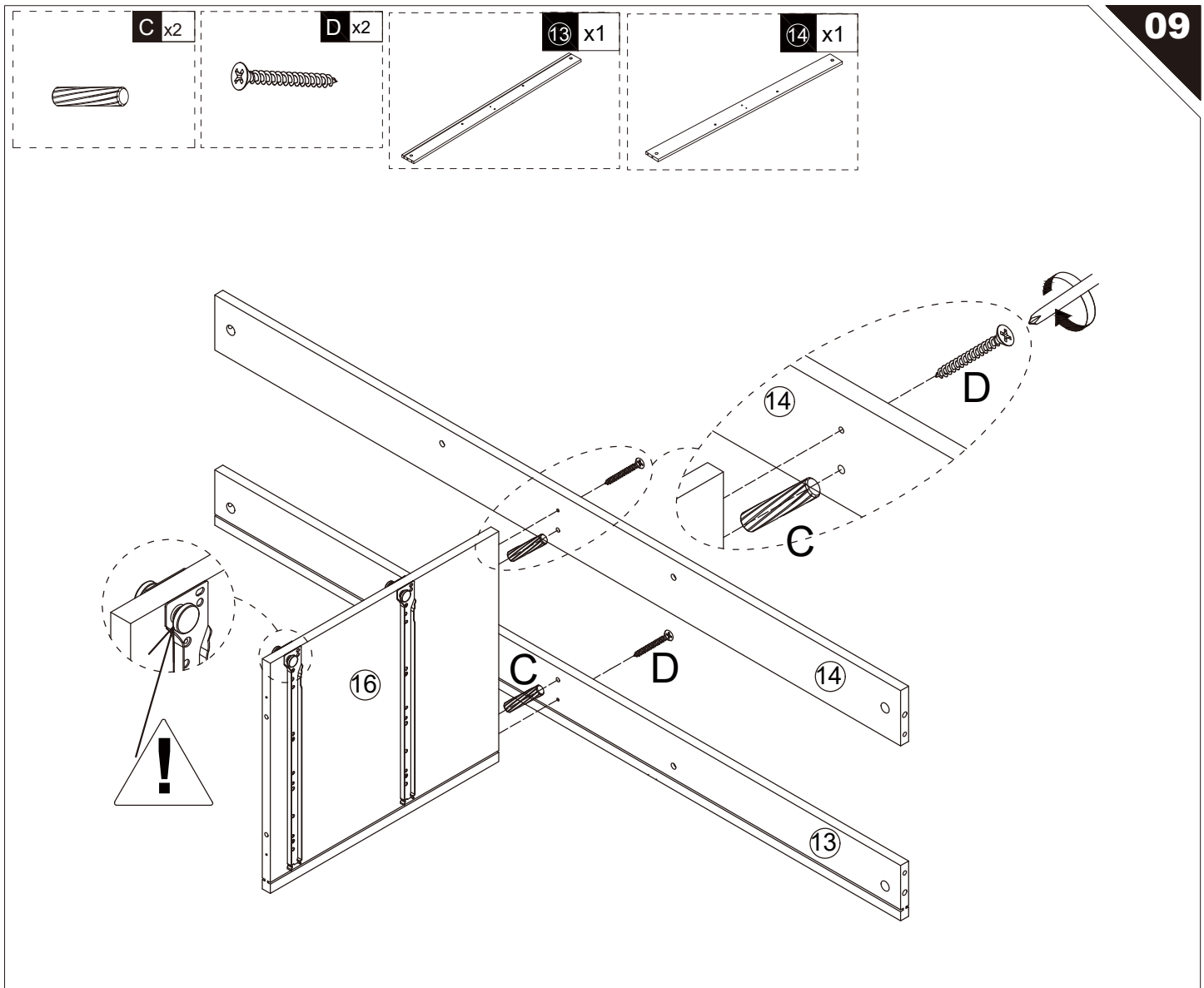
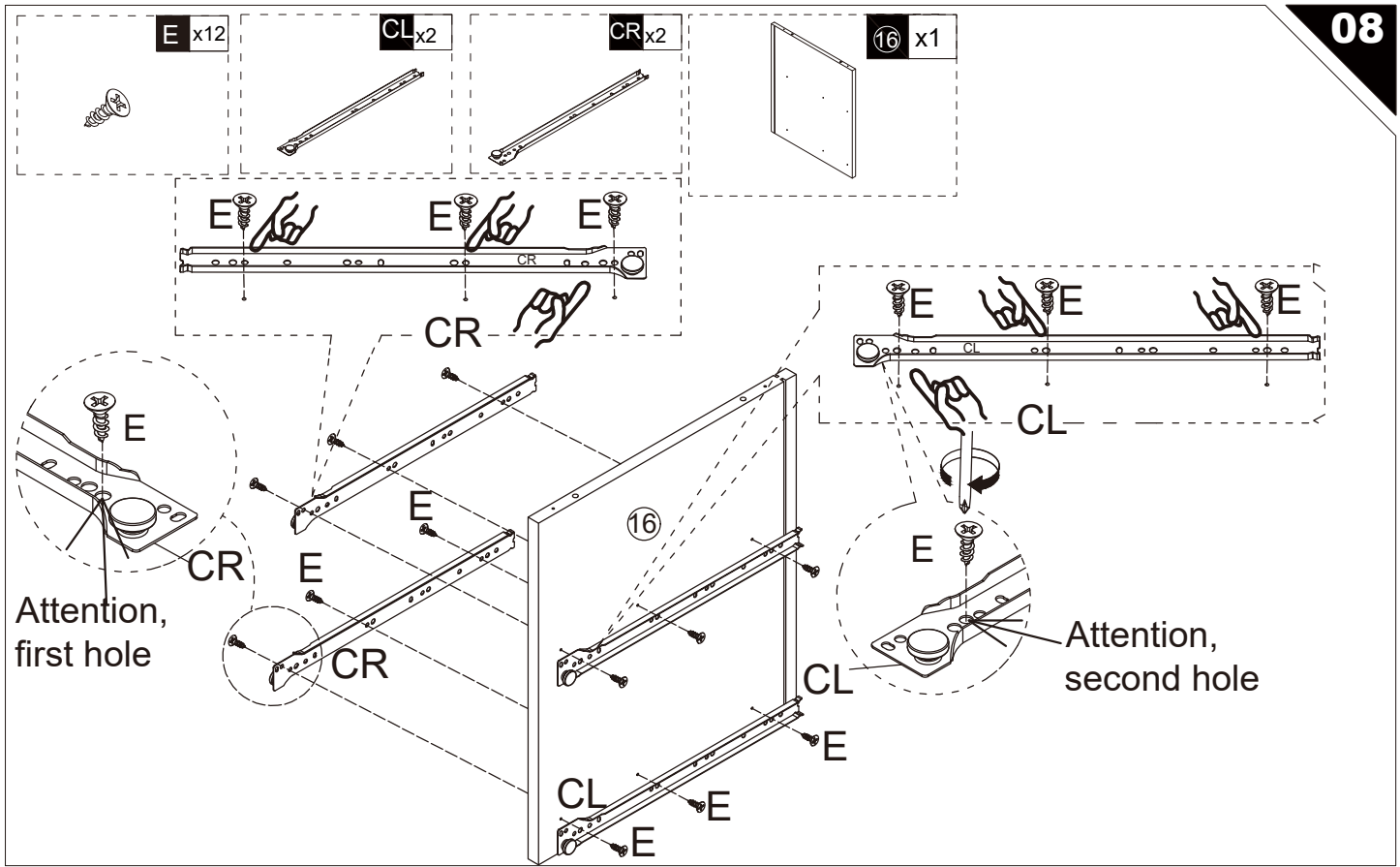

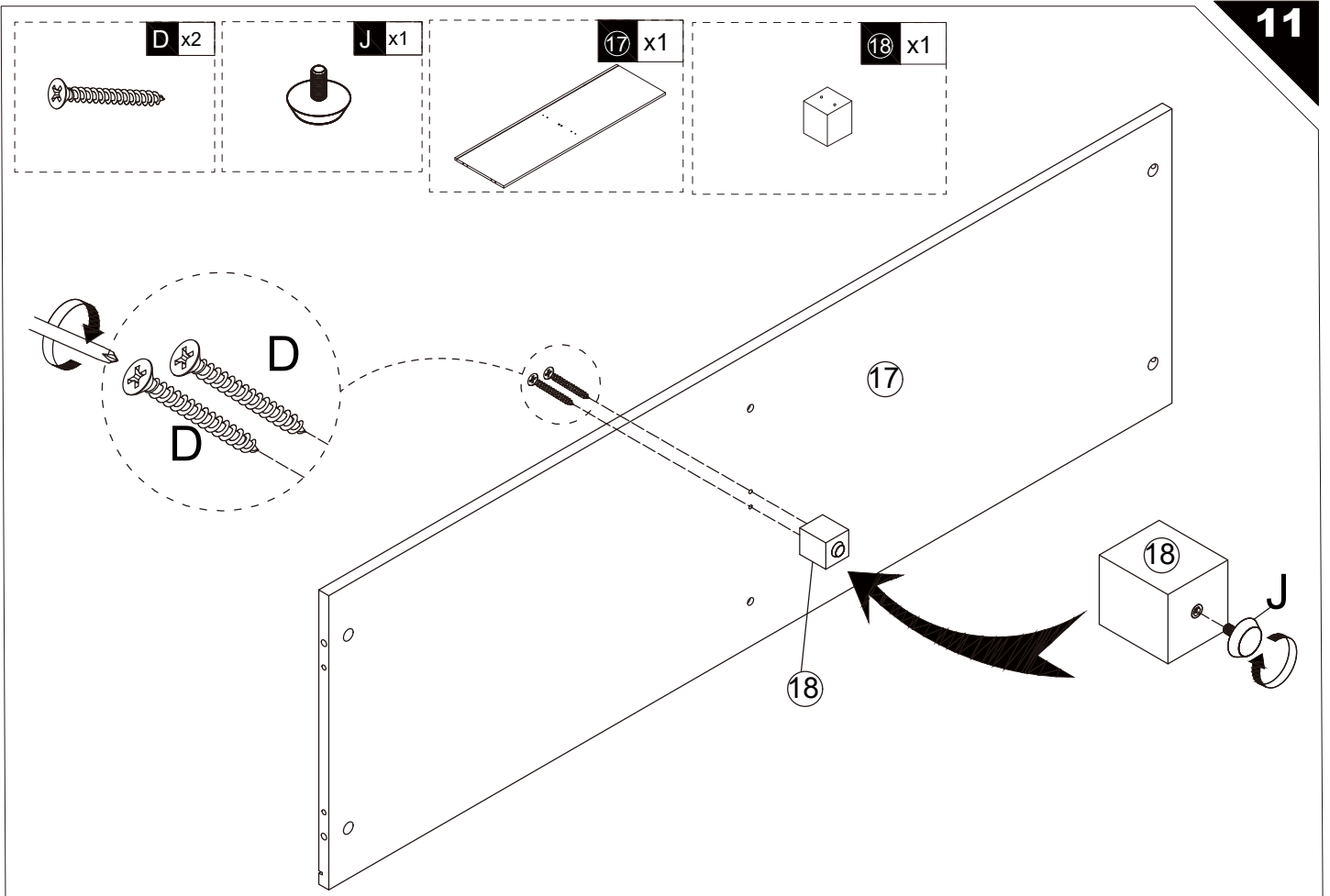
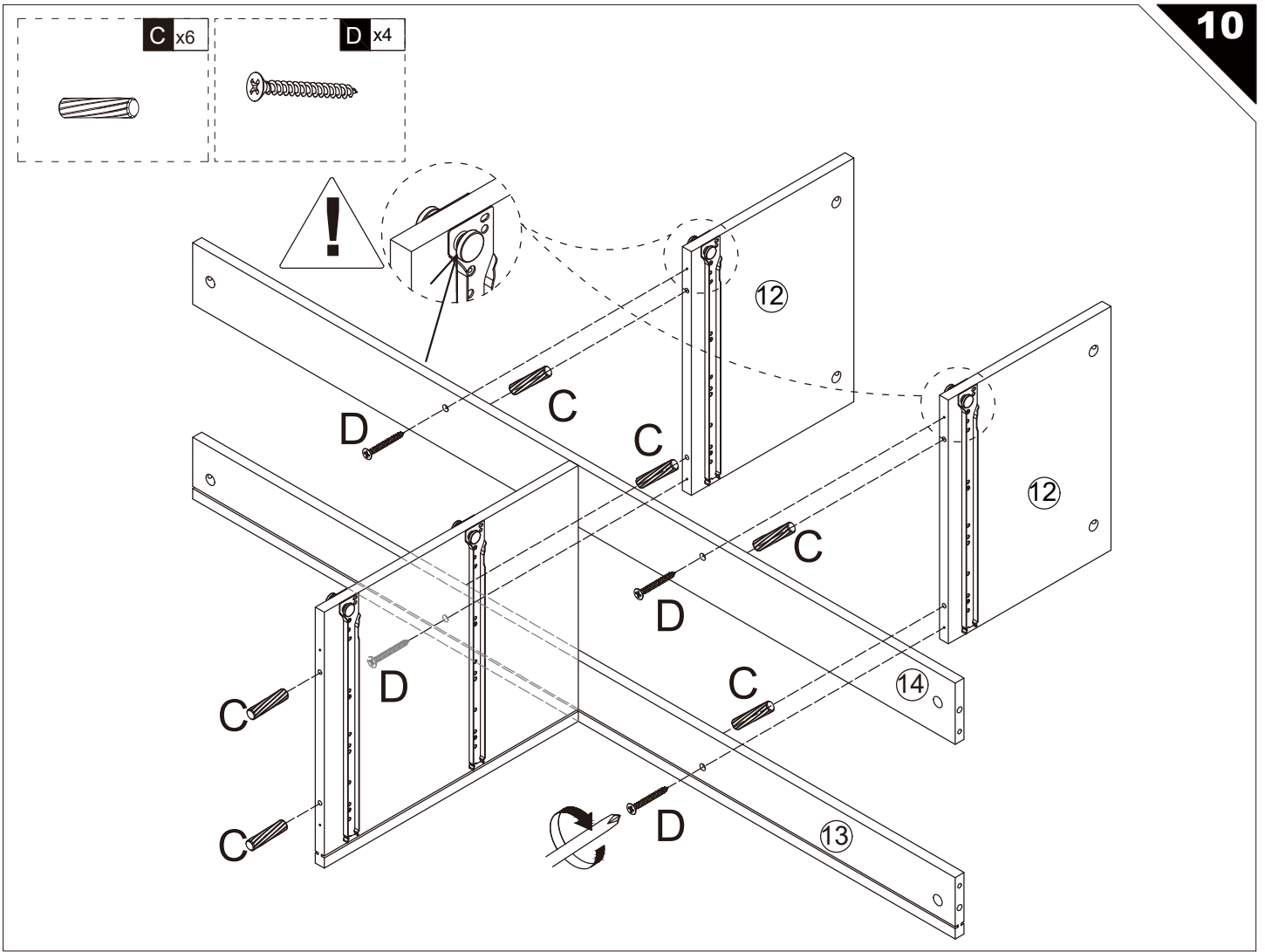

C x8

D x2

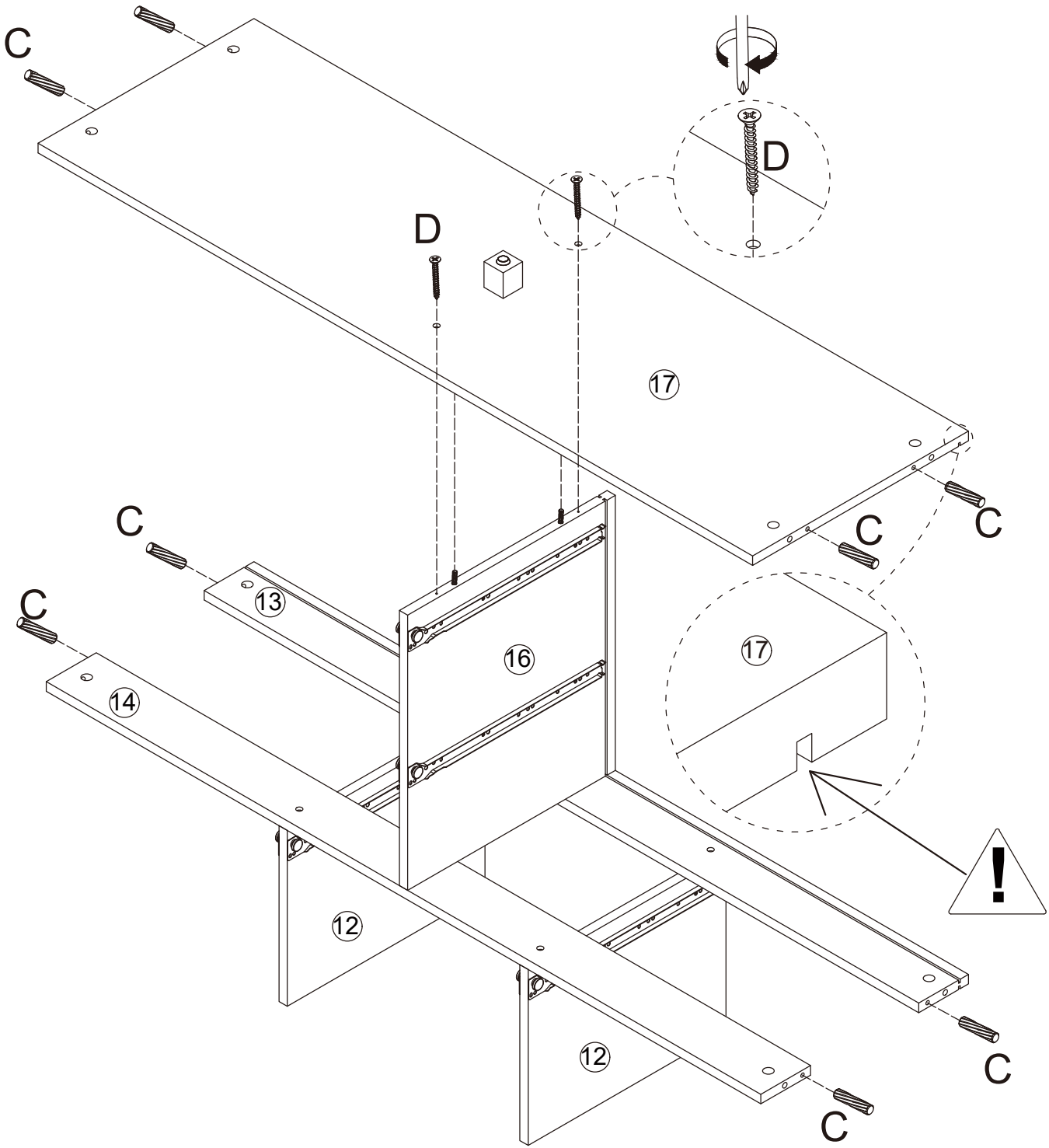

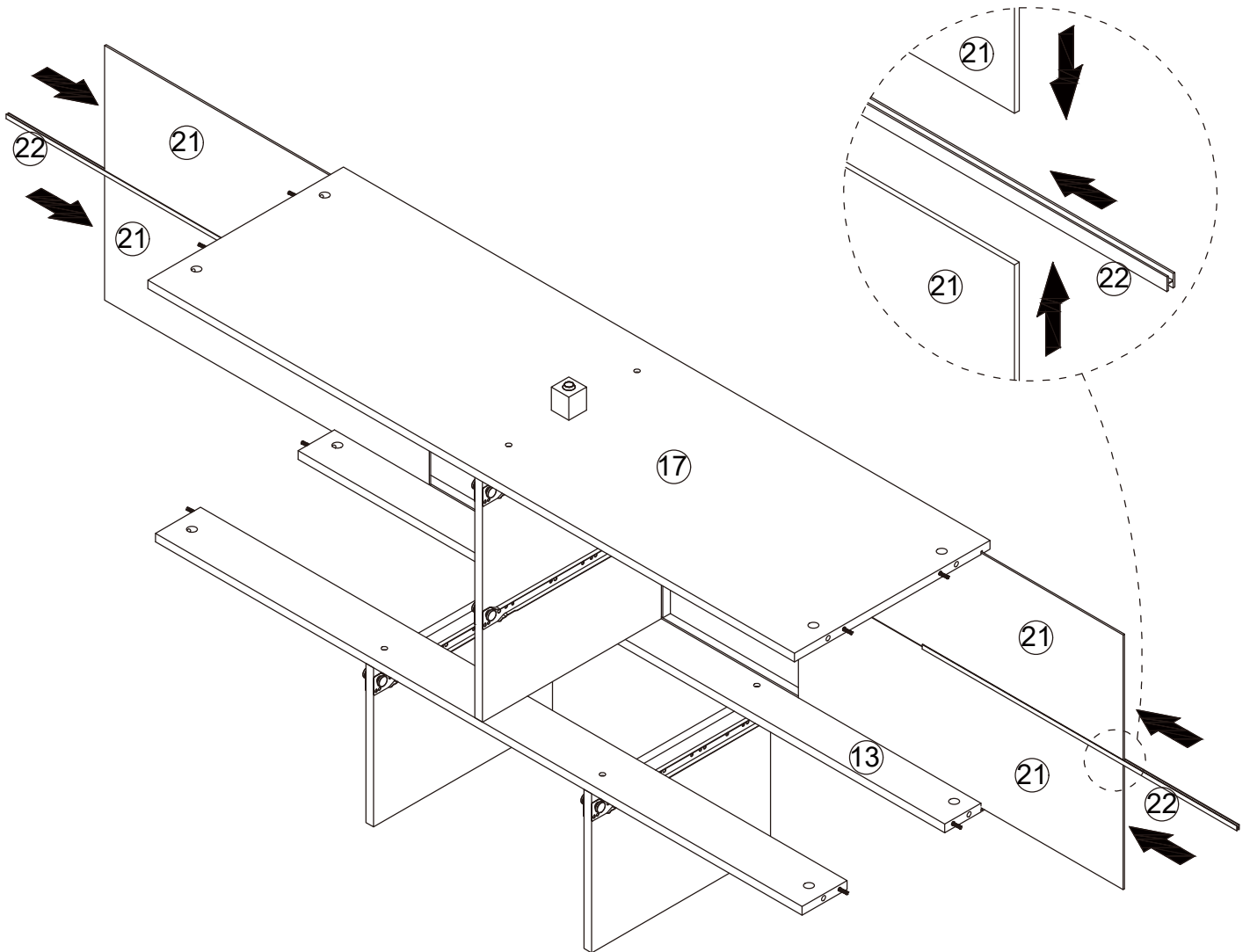
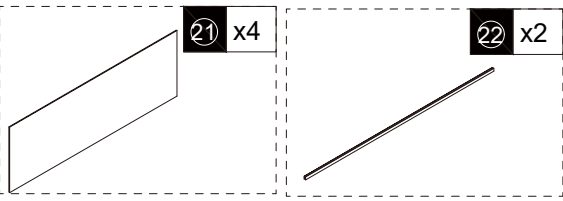

B x4

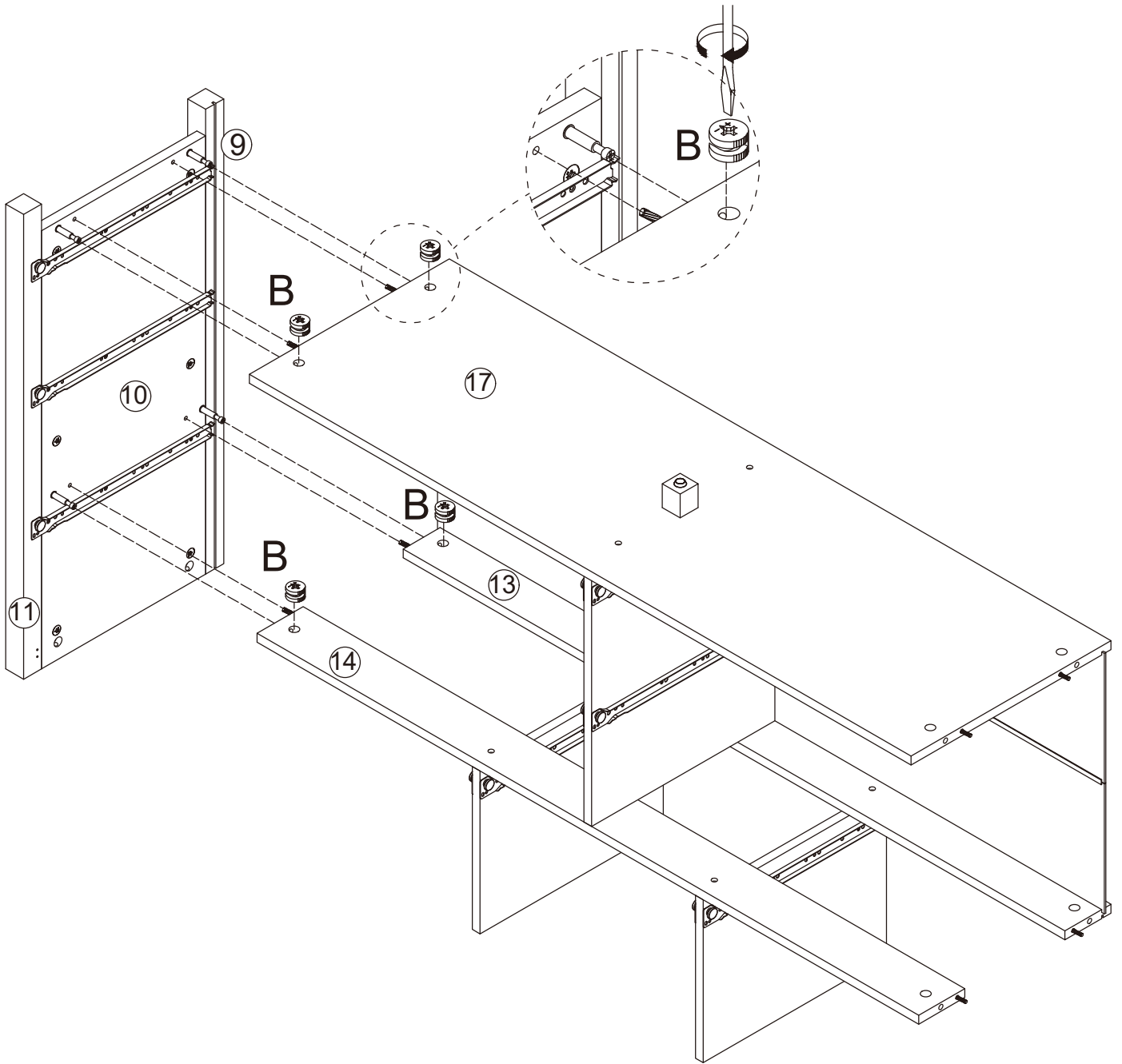
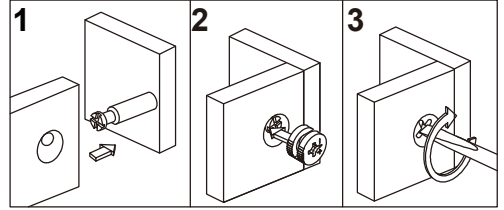

B x4

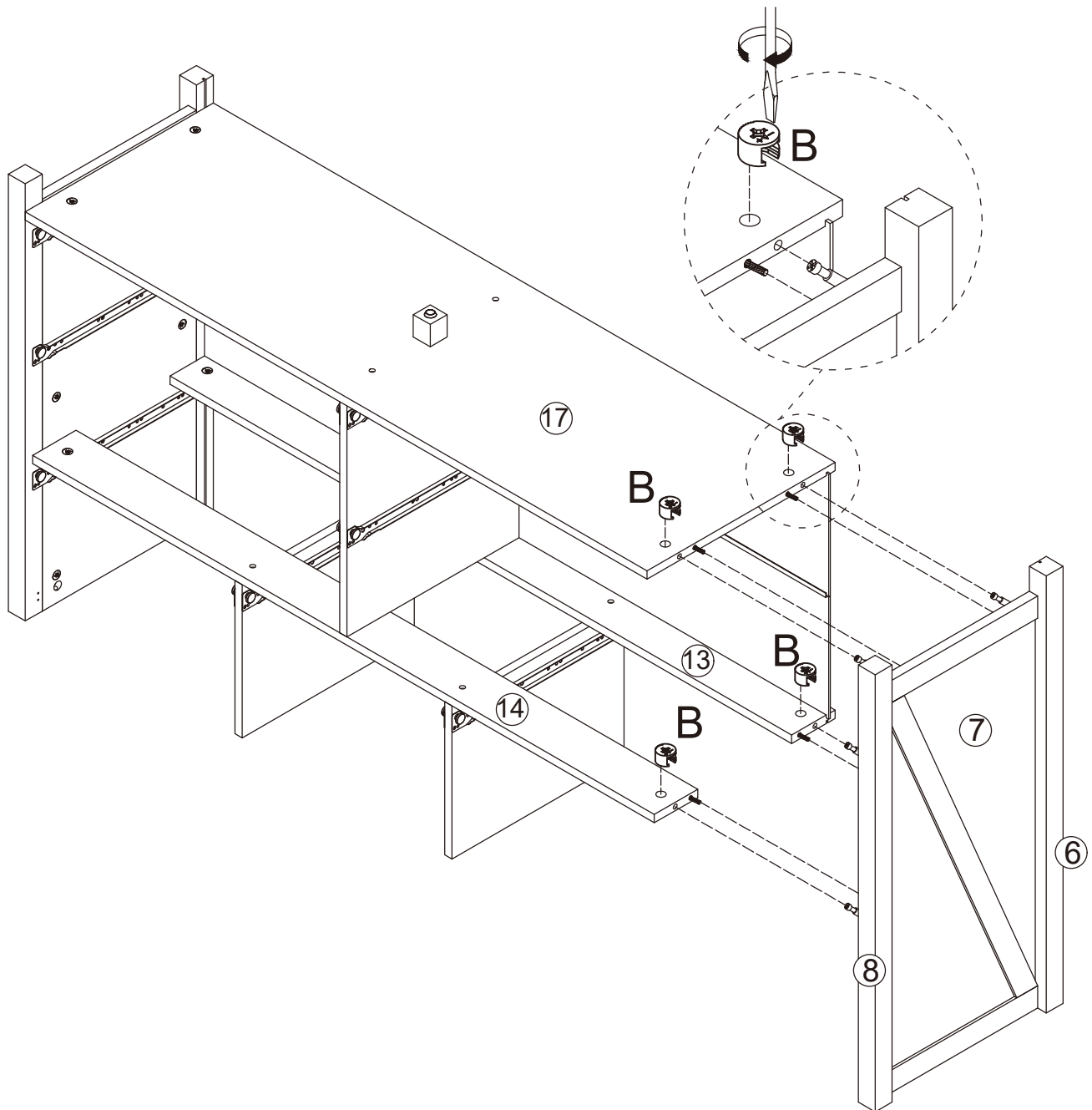
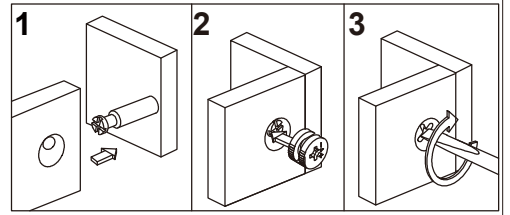

E x12

H x6

K x4

15 x1

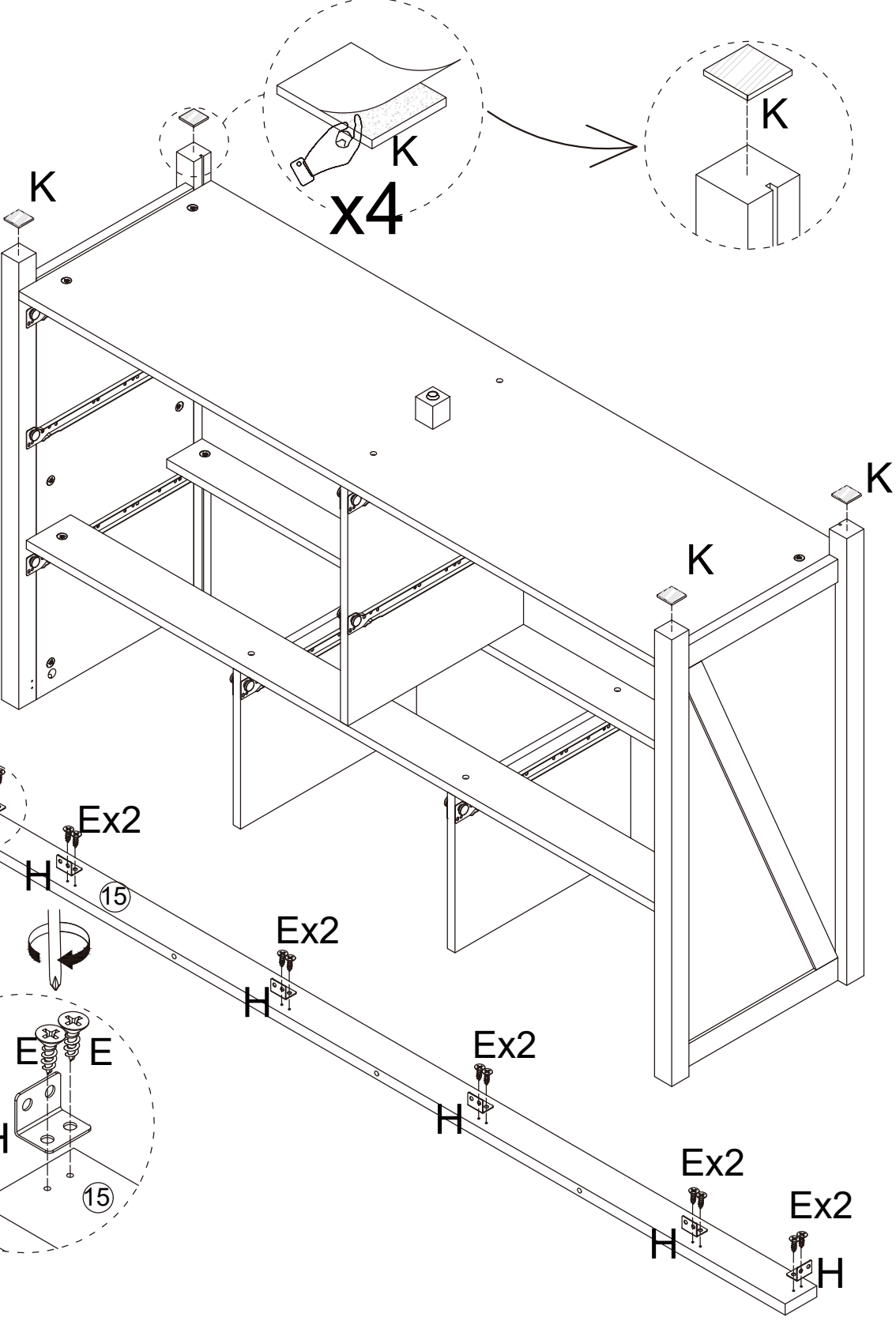
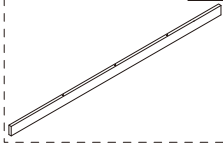

E x4

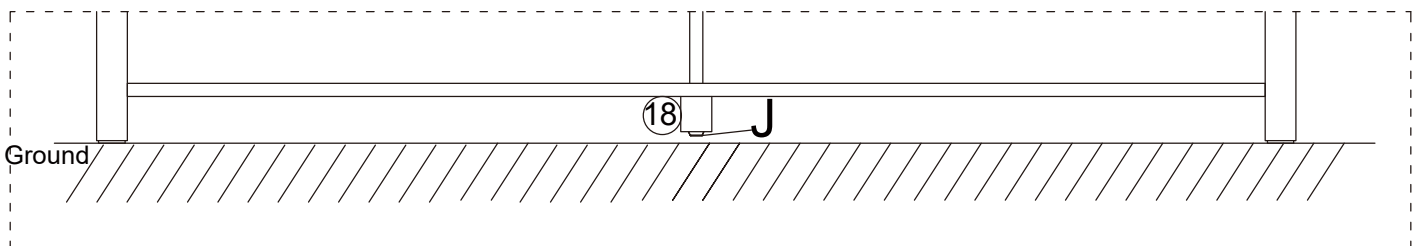
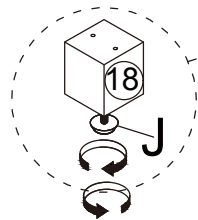
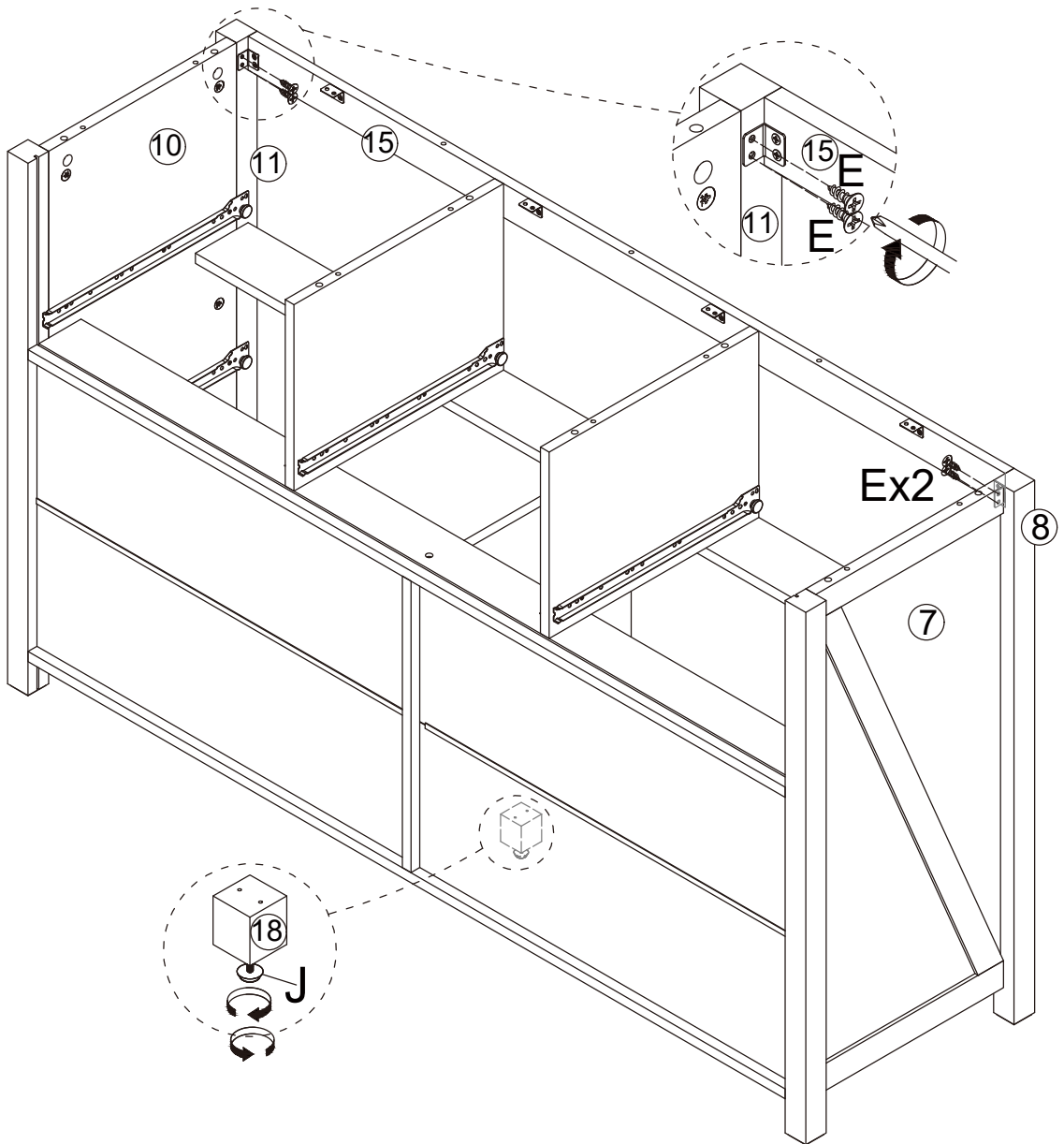

If there is sinking or unevenness with the ground in the middle of the cabinet, please adjust it by rotating the adjustable foot pad (J) under No. 18

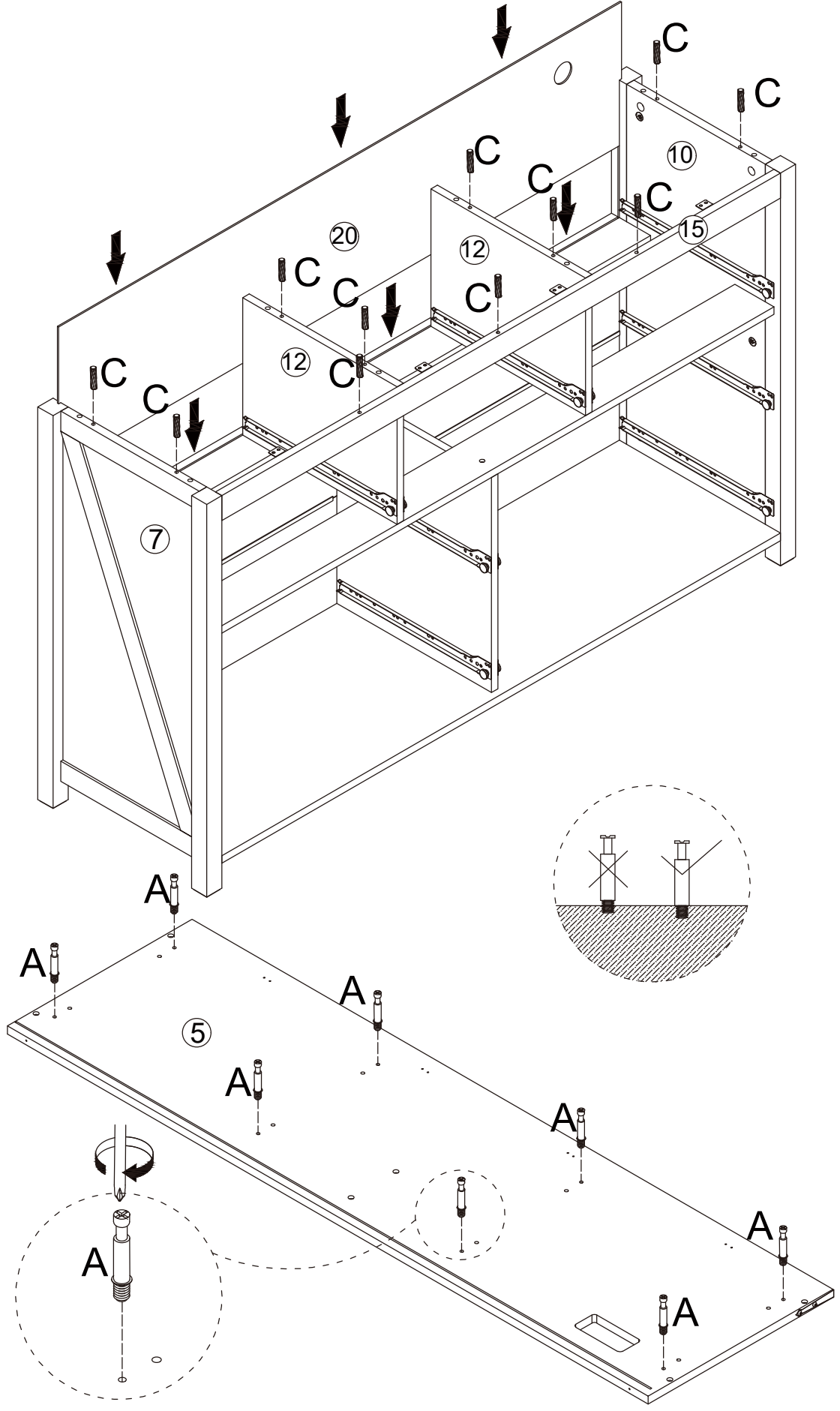
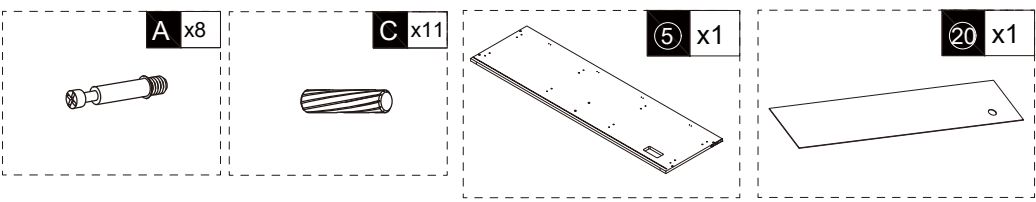

C x6

D x6

② x1

③ x1

④ x1

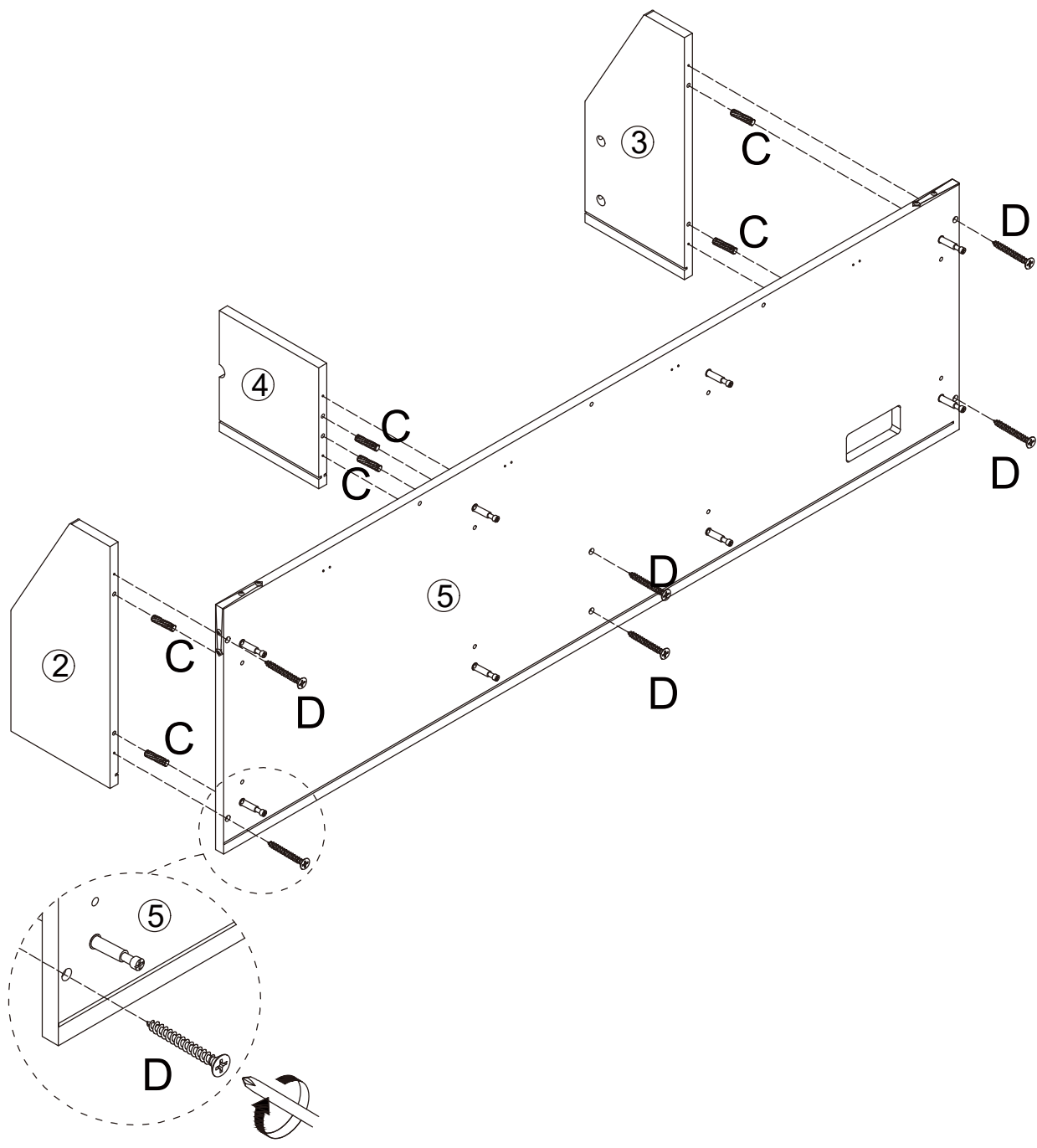
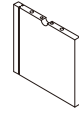
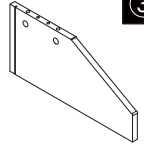
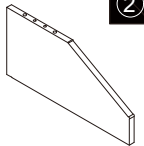

B x8

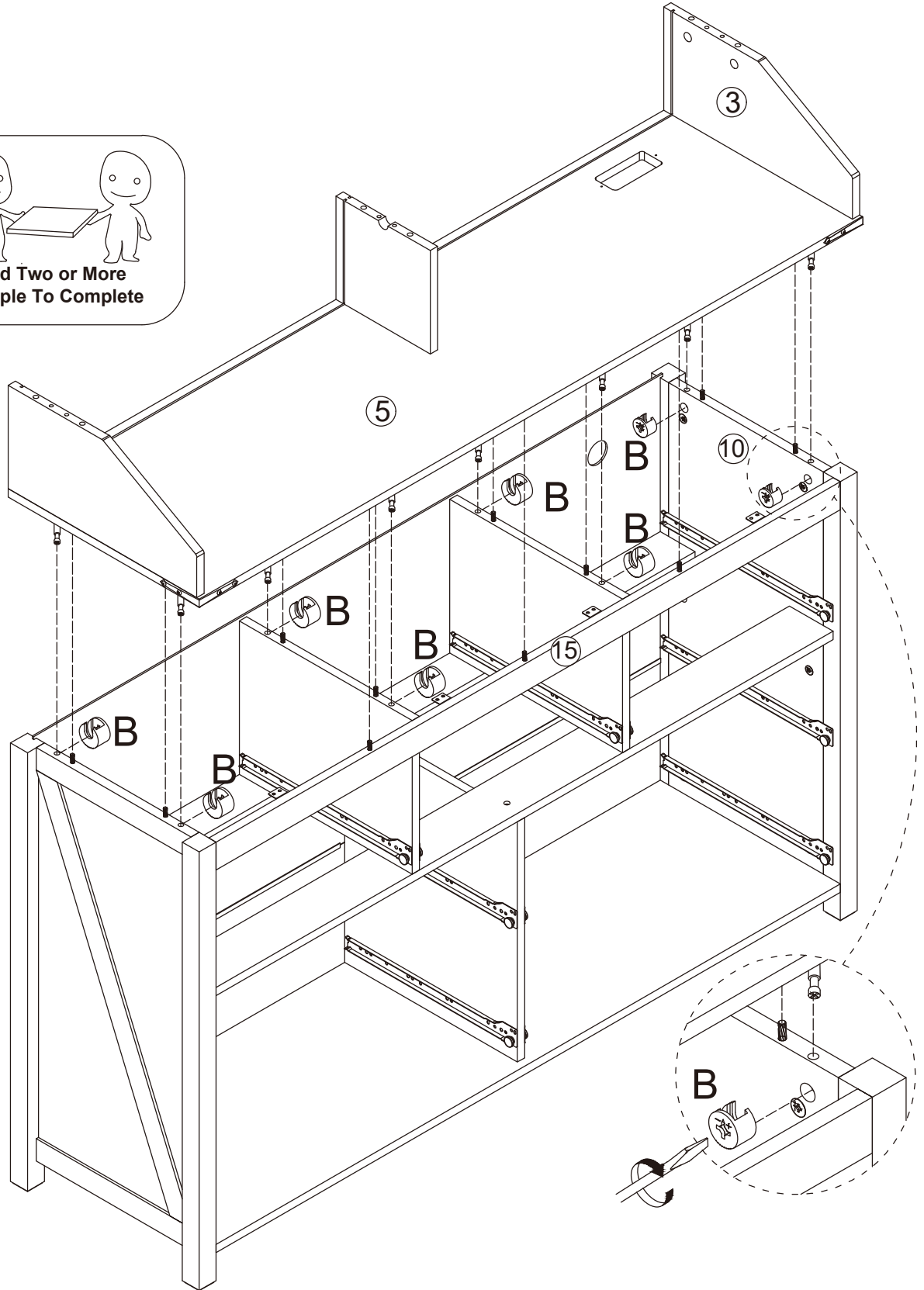
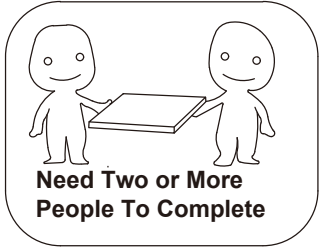
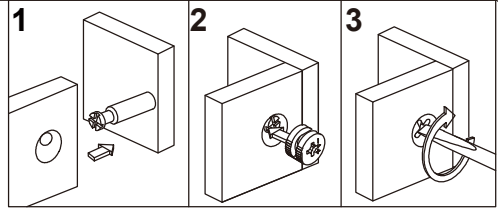

E x8

F x1

G x2

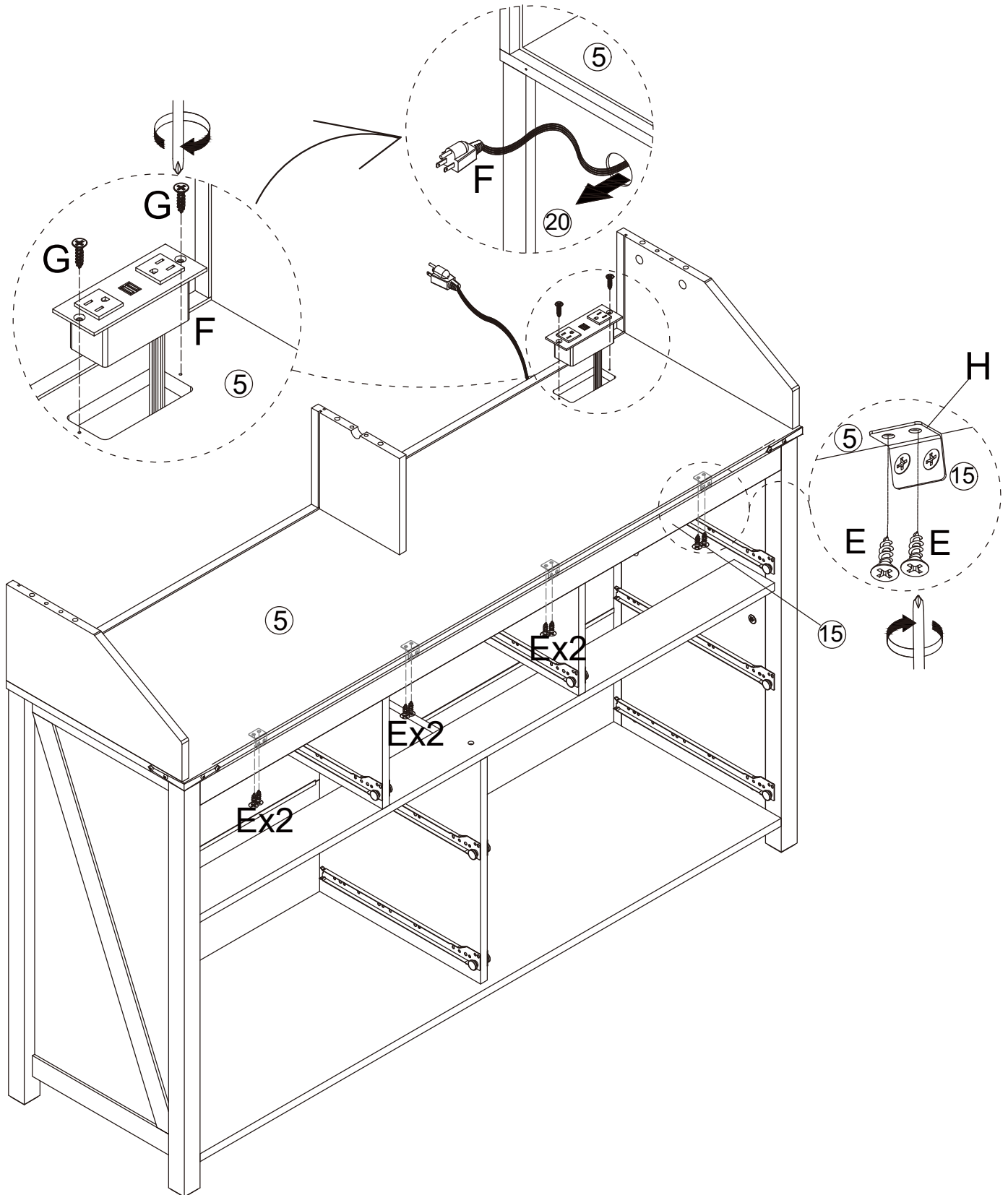
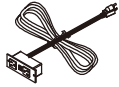

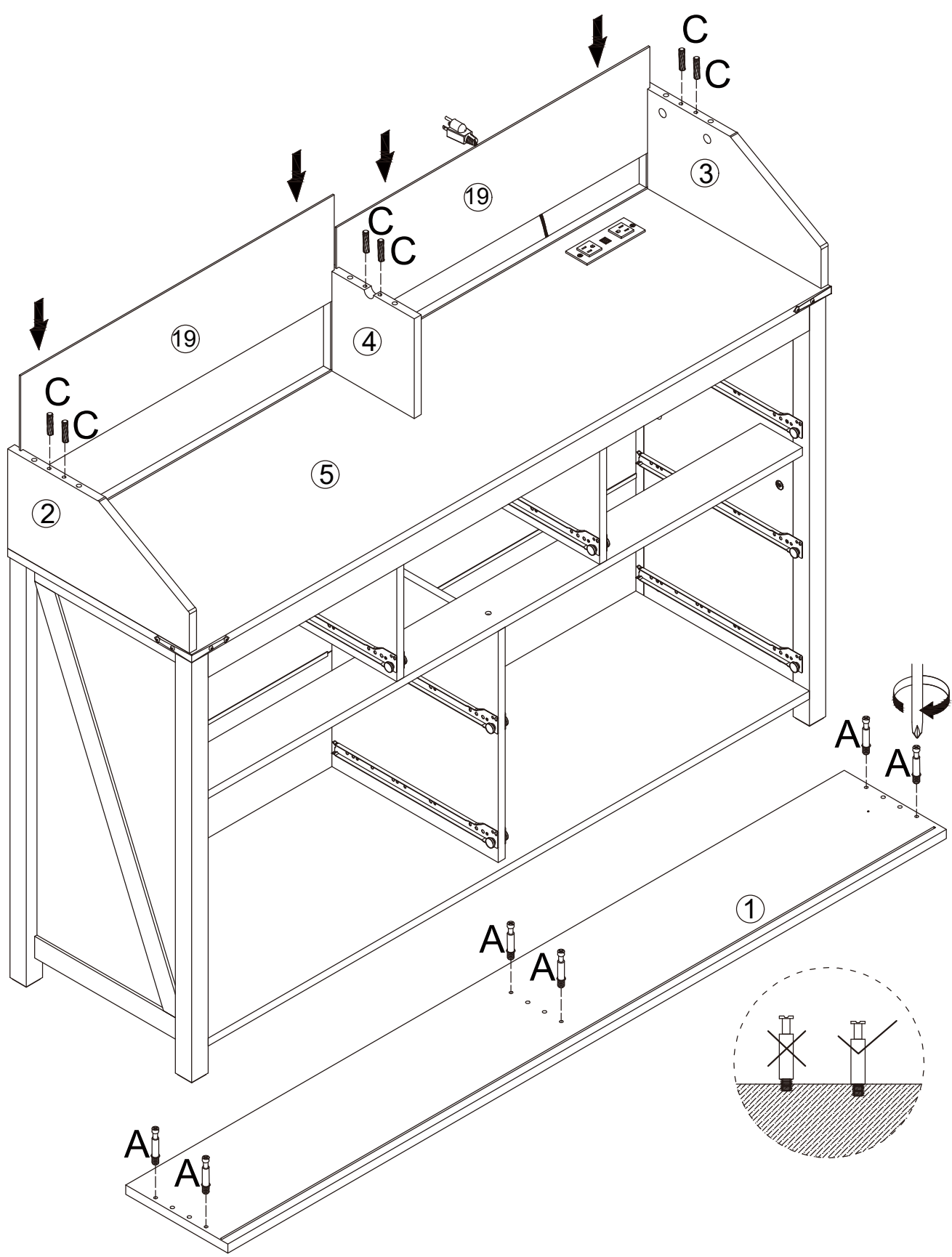
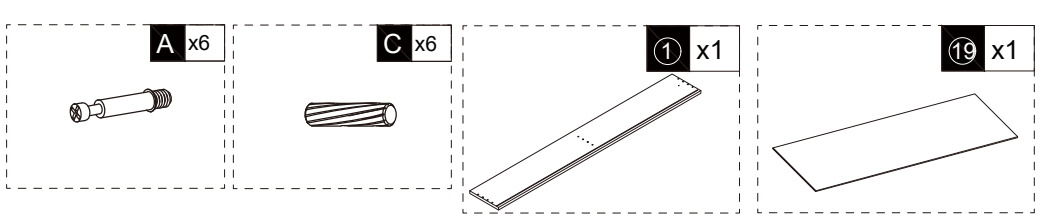

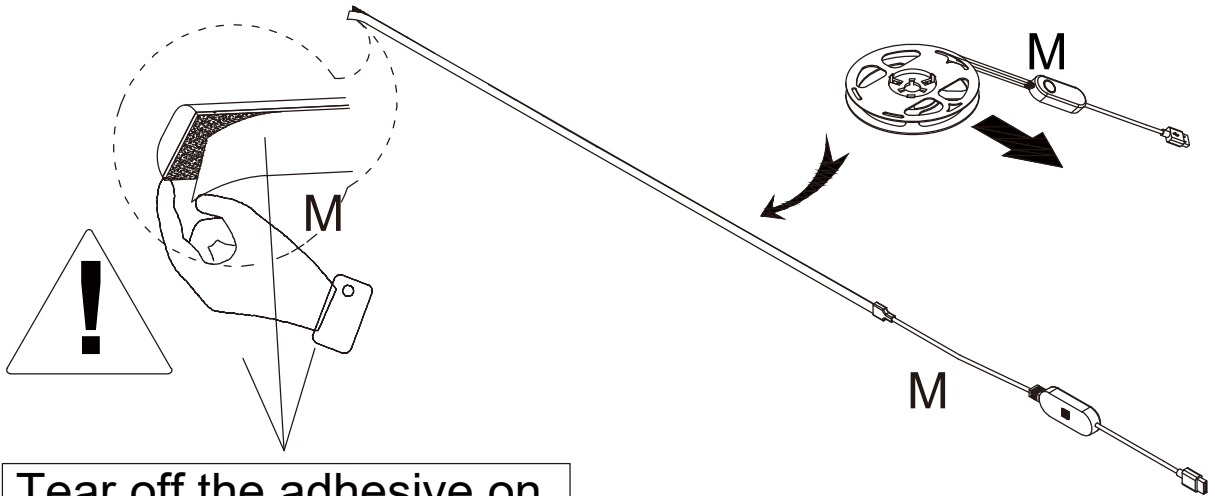
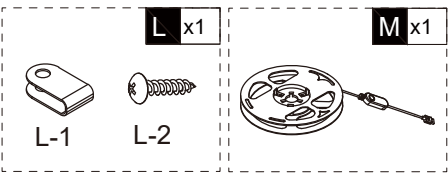

Tear off the adhesive on the back of the light strip

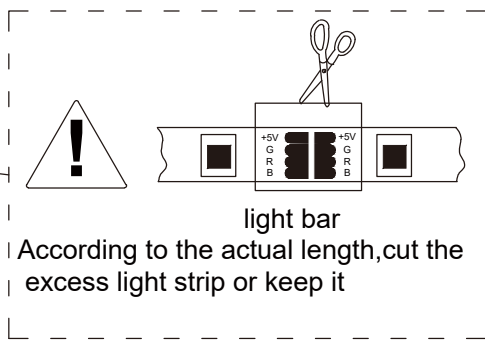
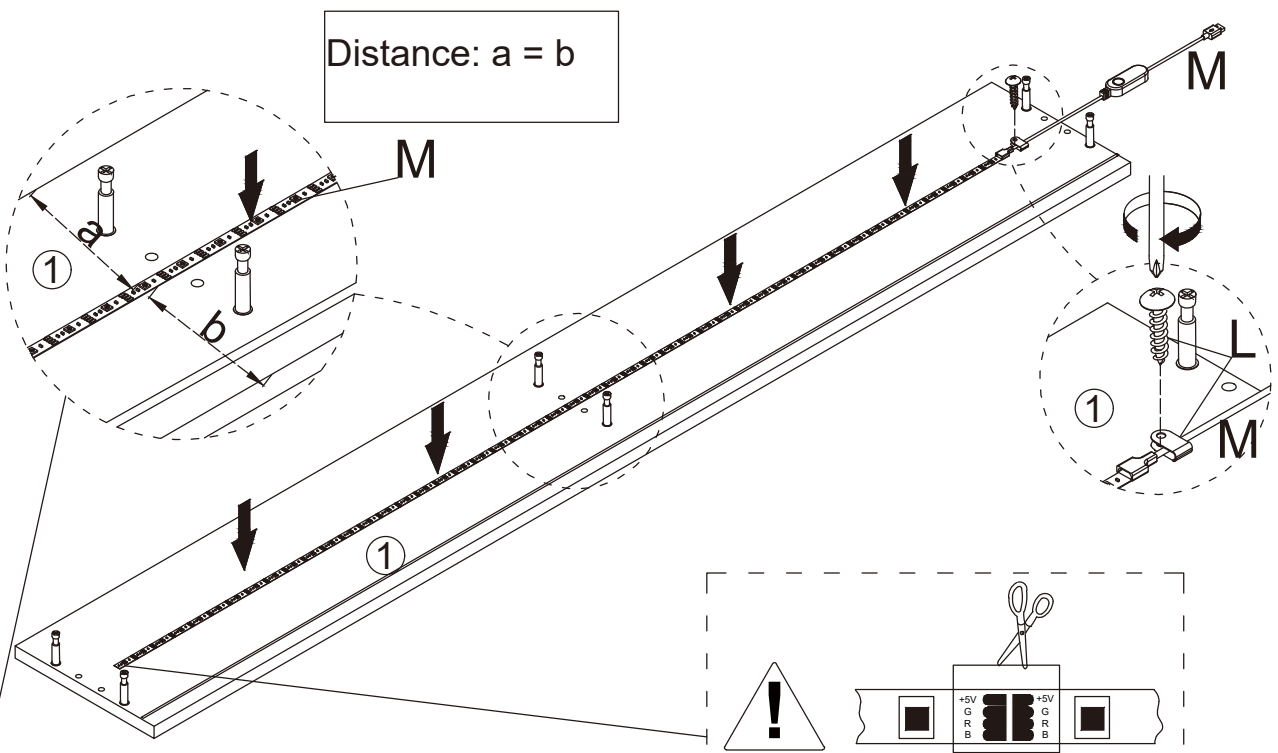

Attention: When pasting the light strip, the light strip should be in the position of pasting on board 1, and the light strip should be in a straight line.



B x6

S x6

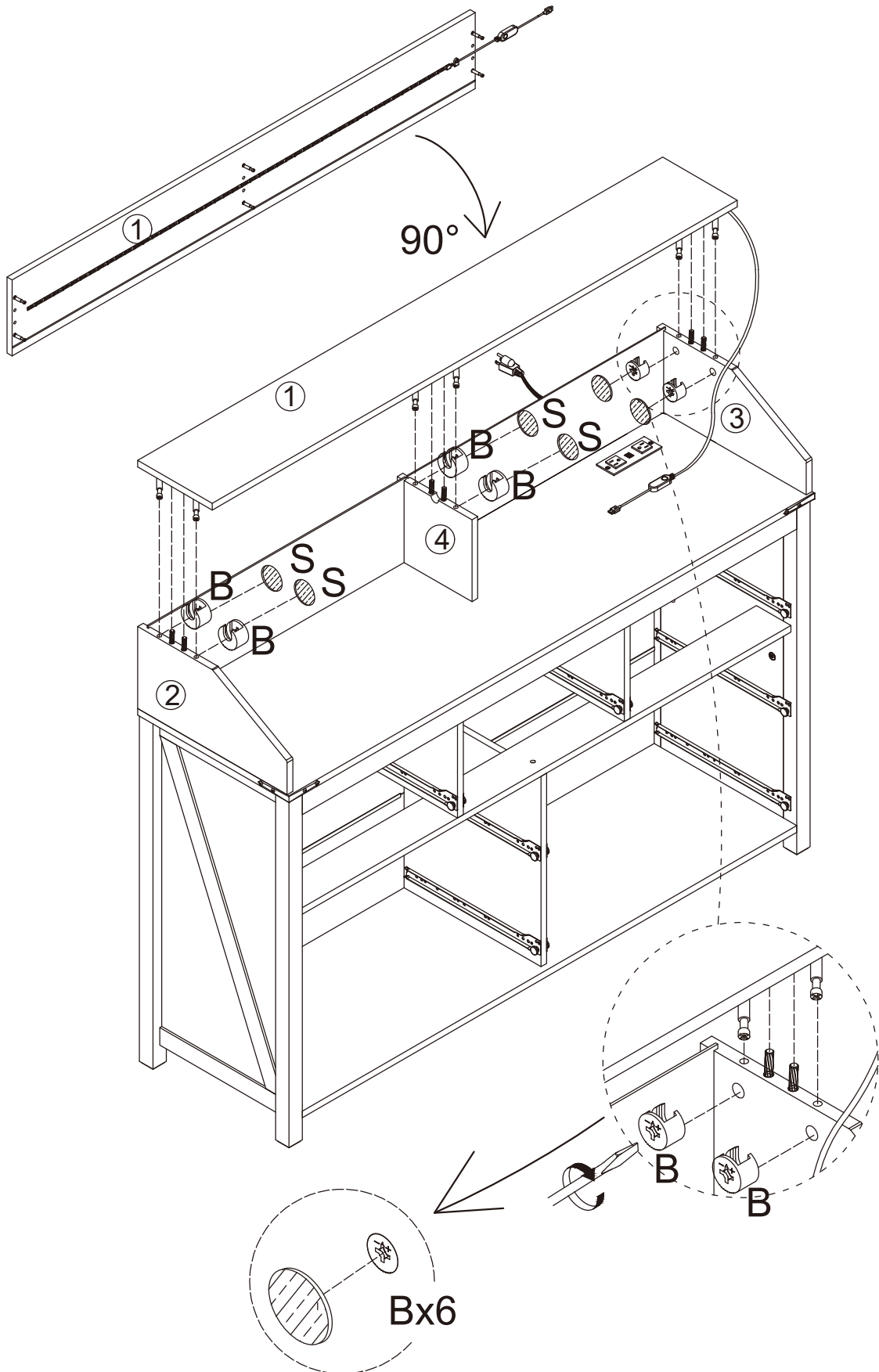
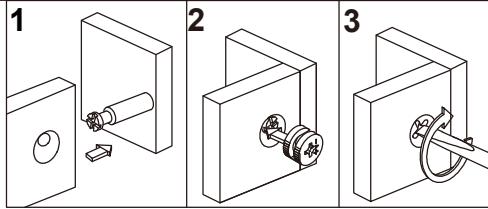

Q x30

R x30

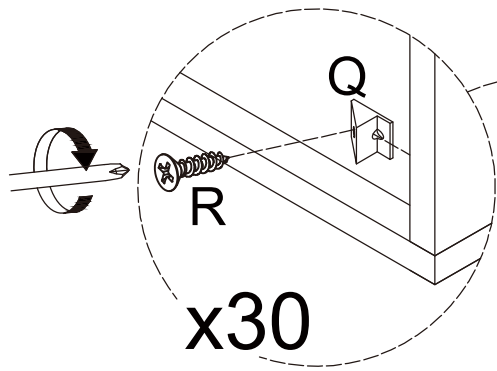
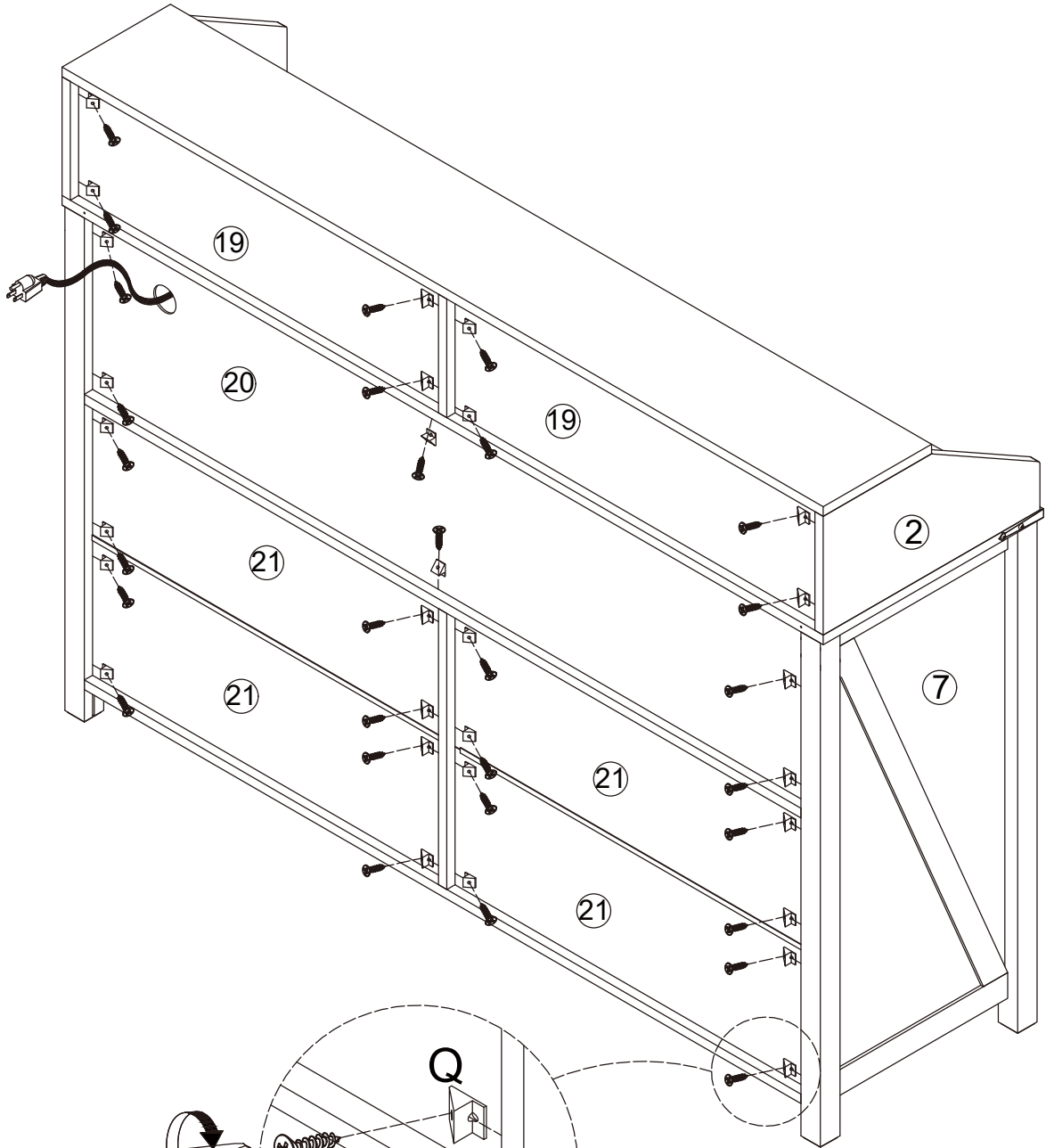

x30

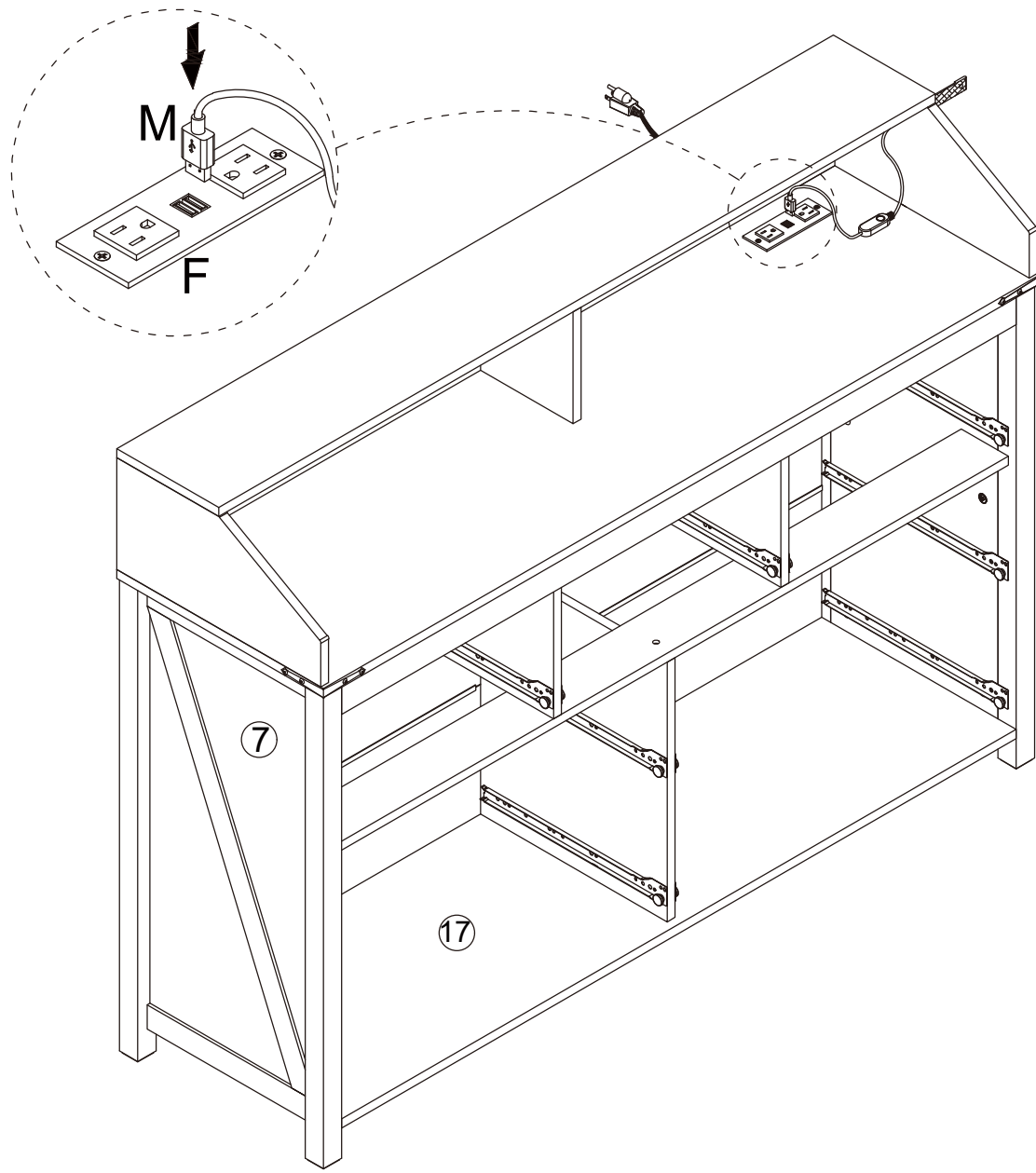

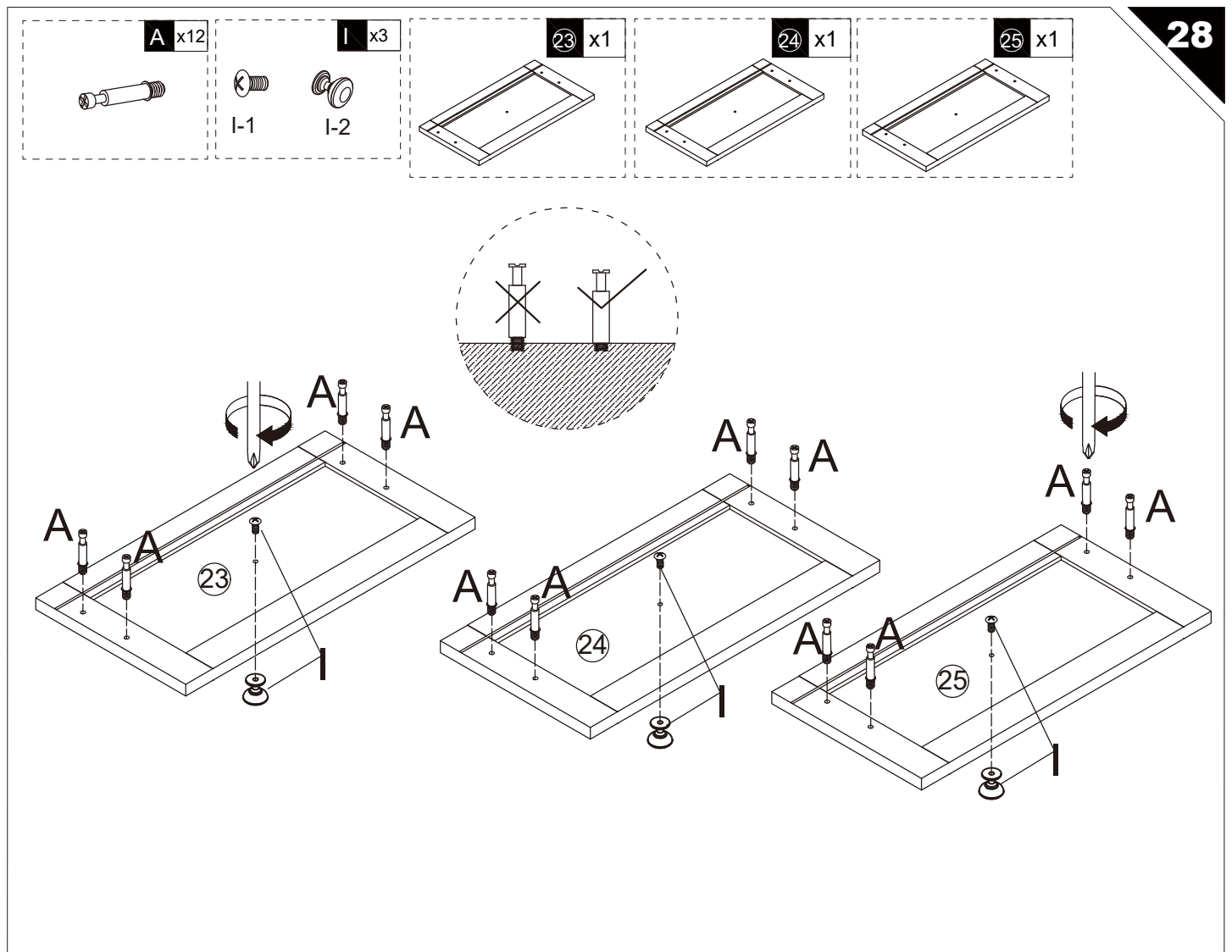
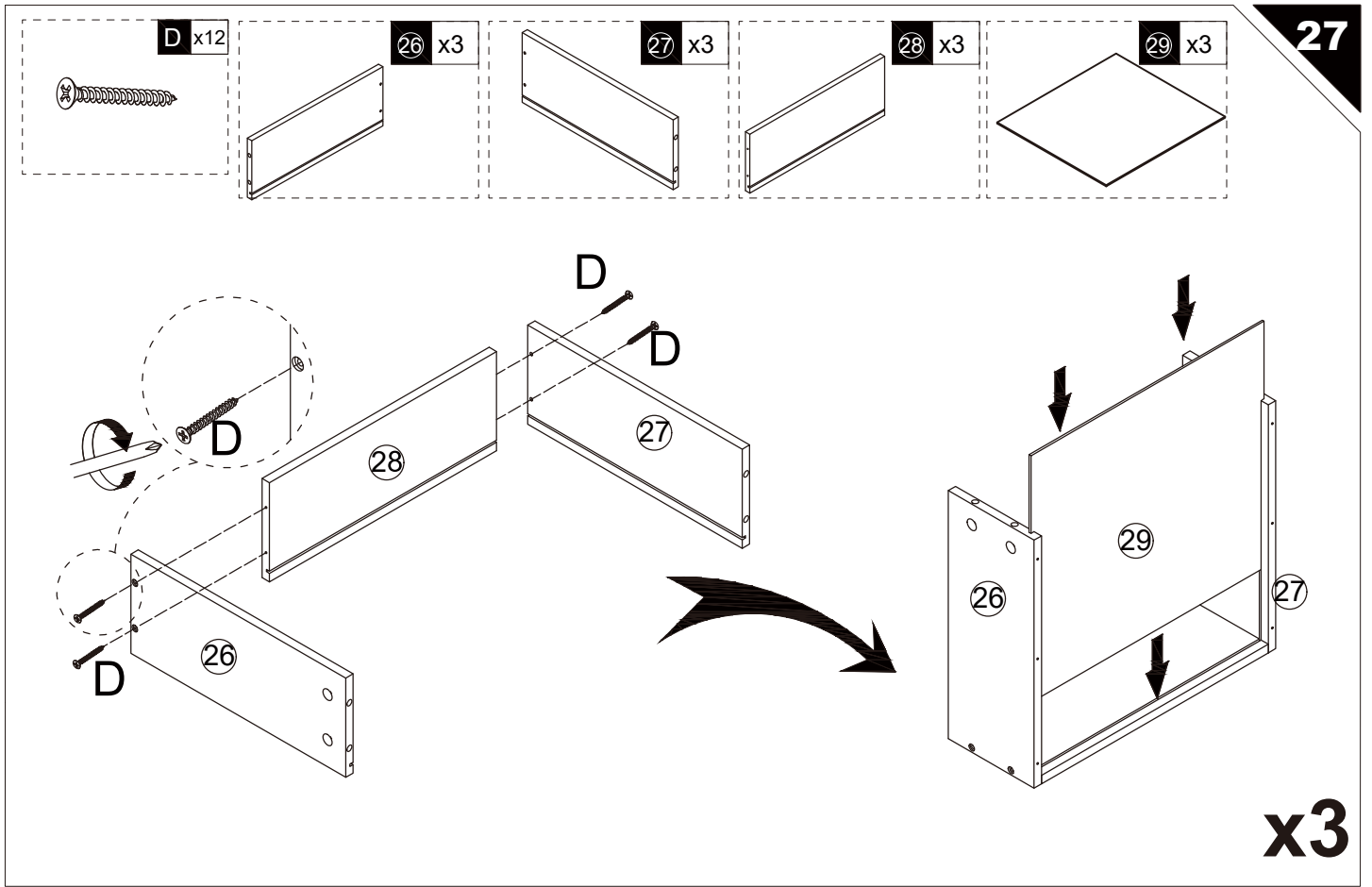

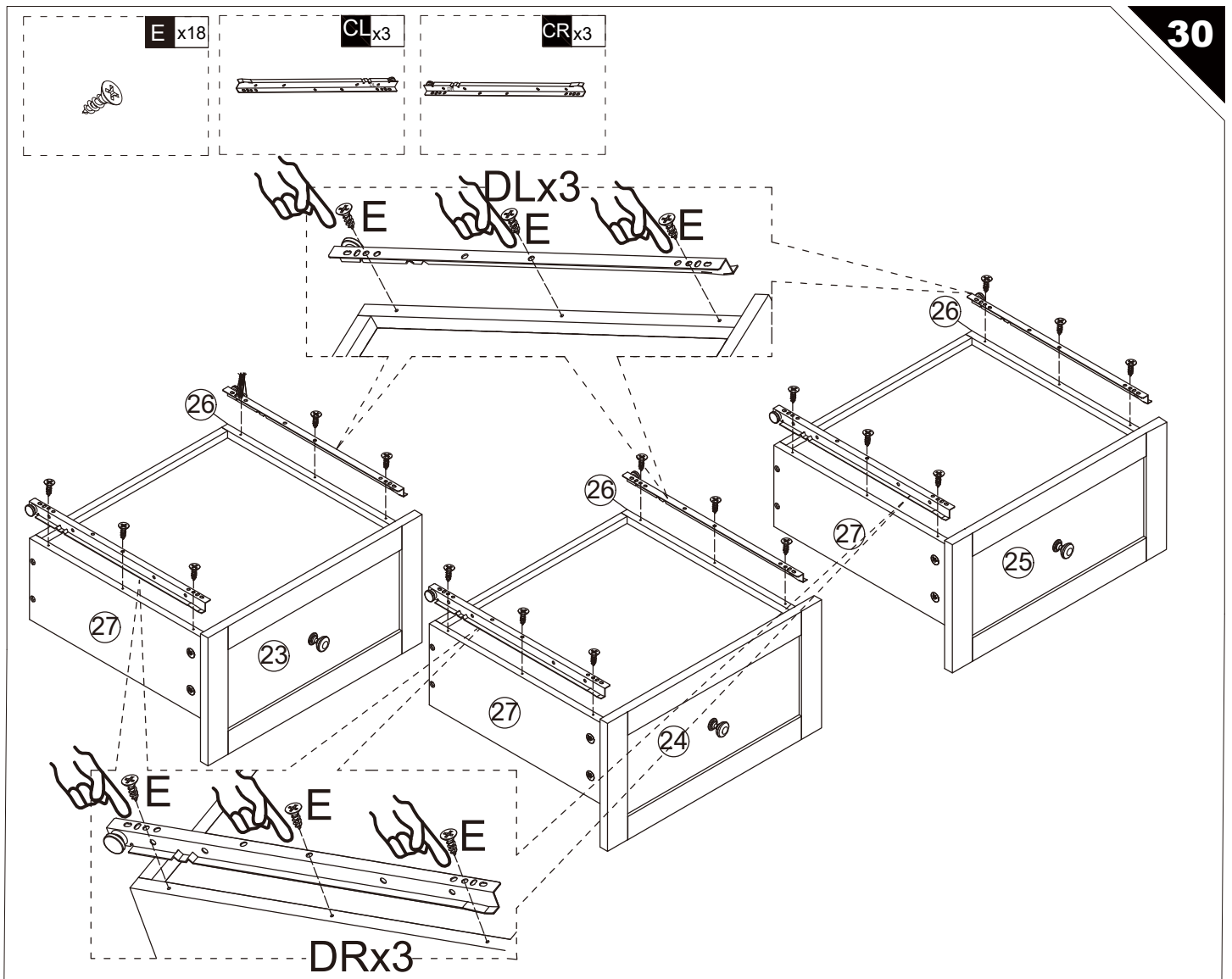
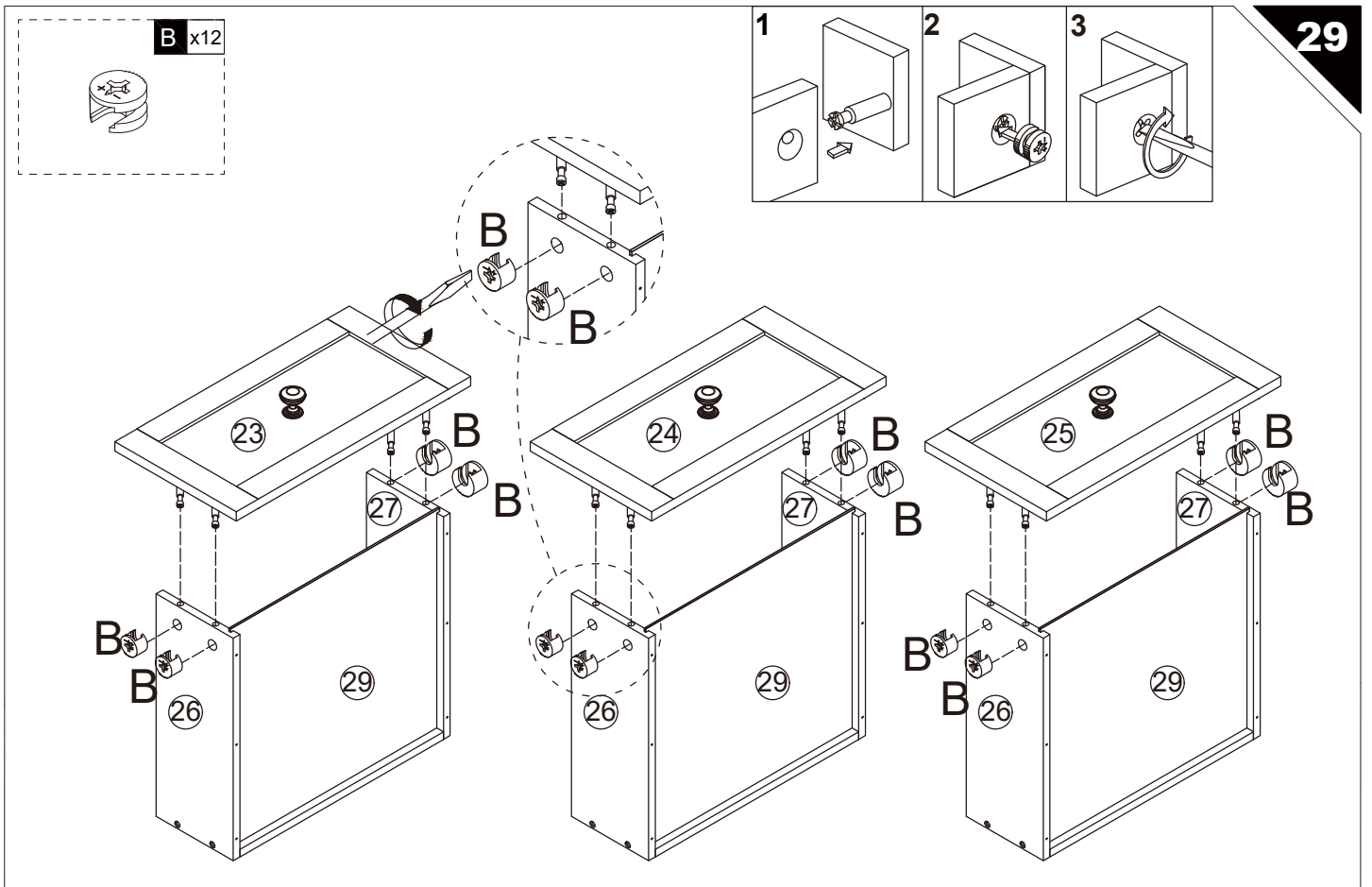

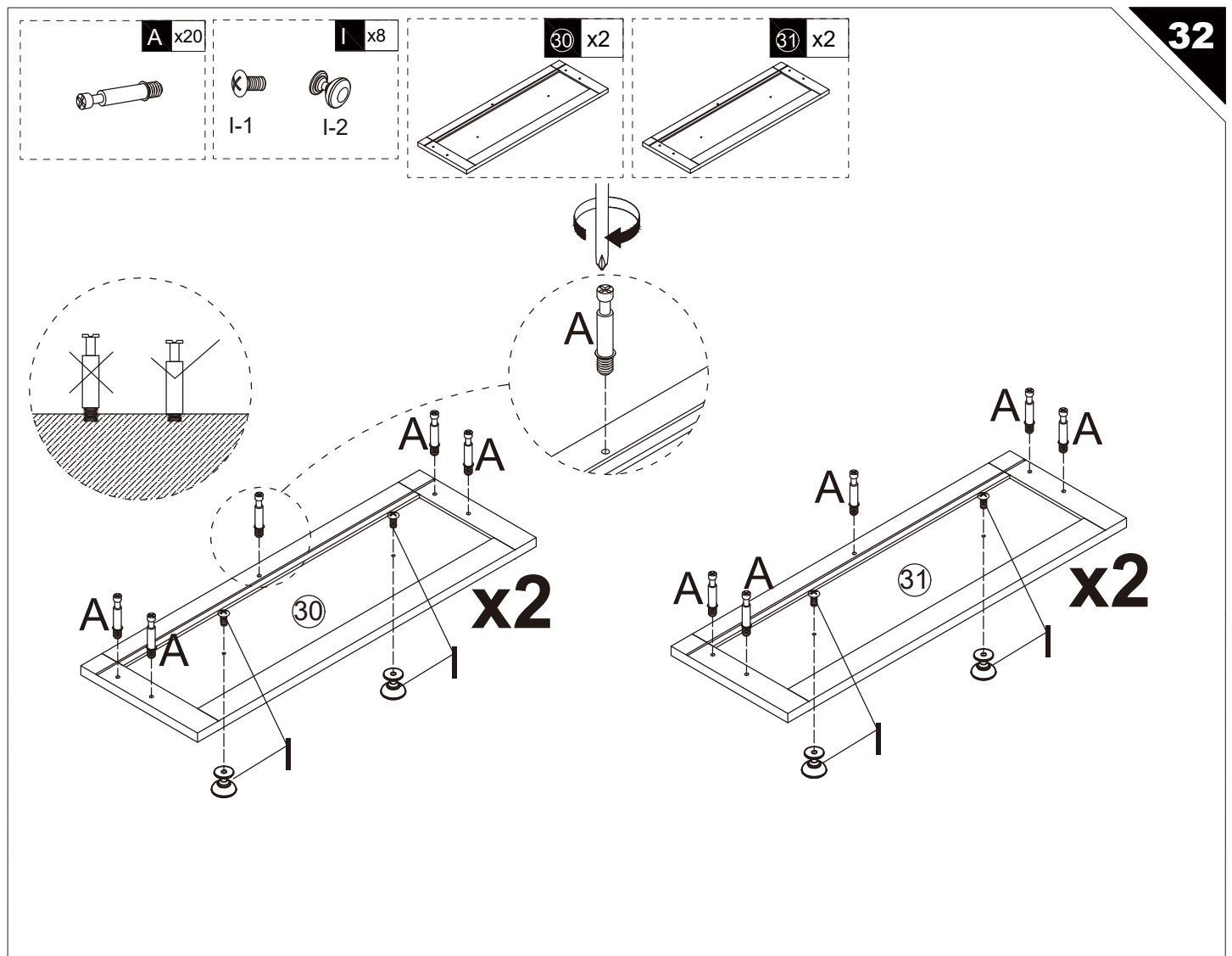
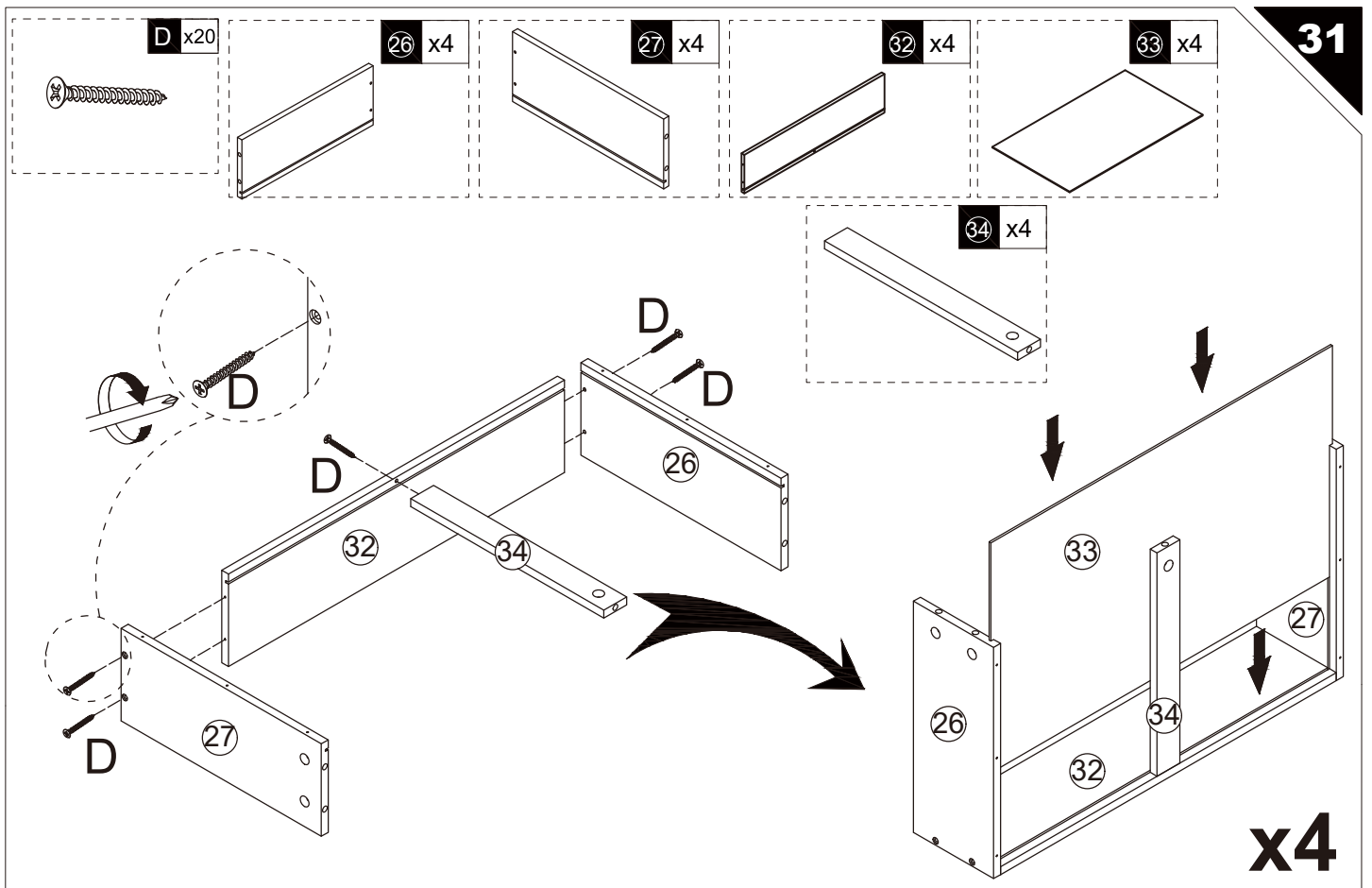

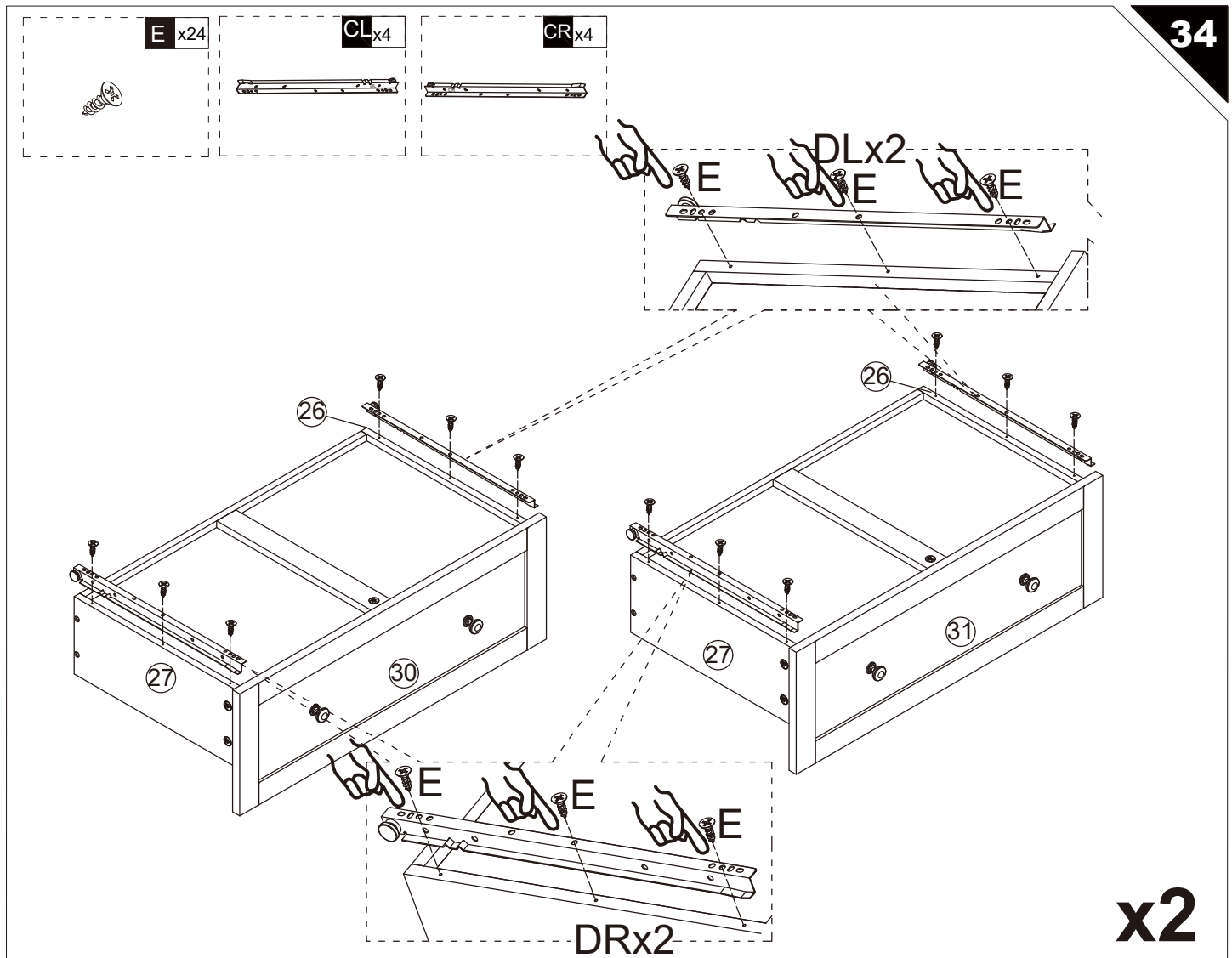
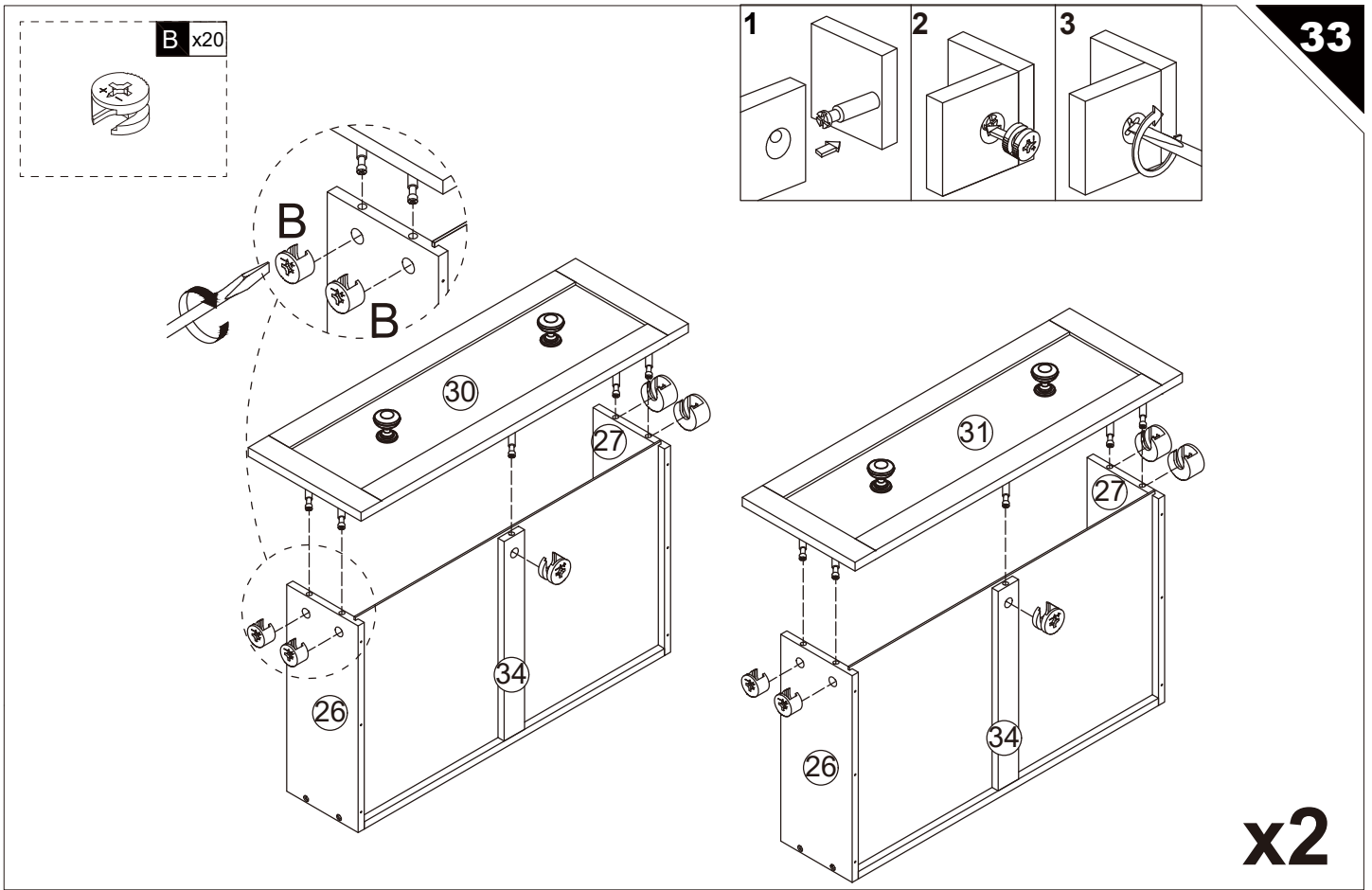

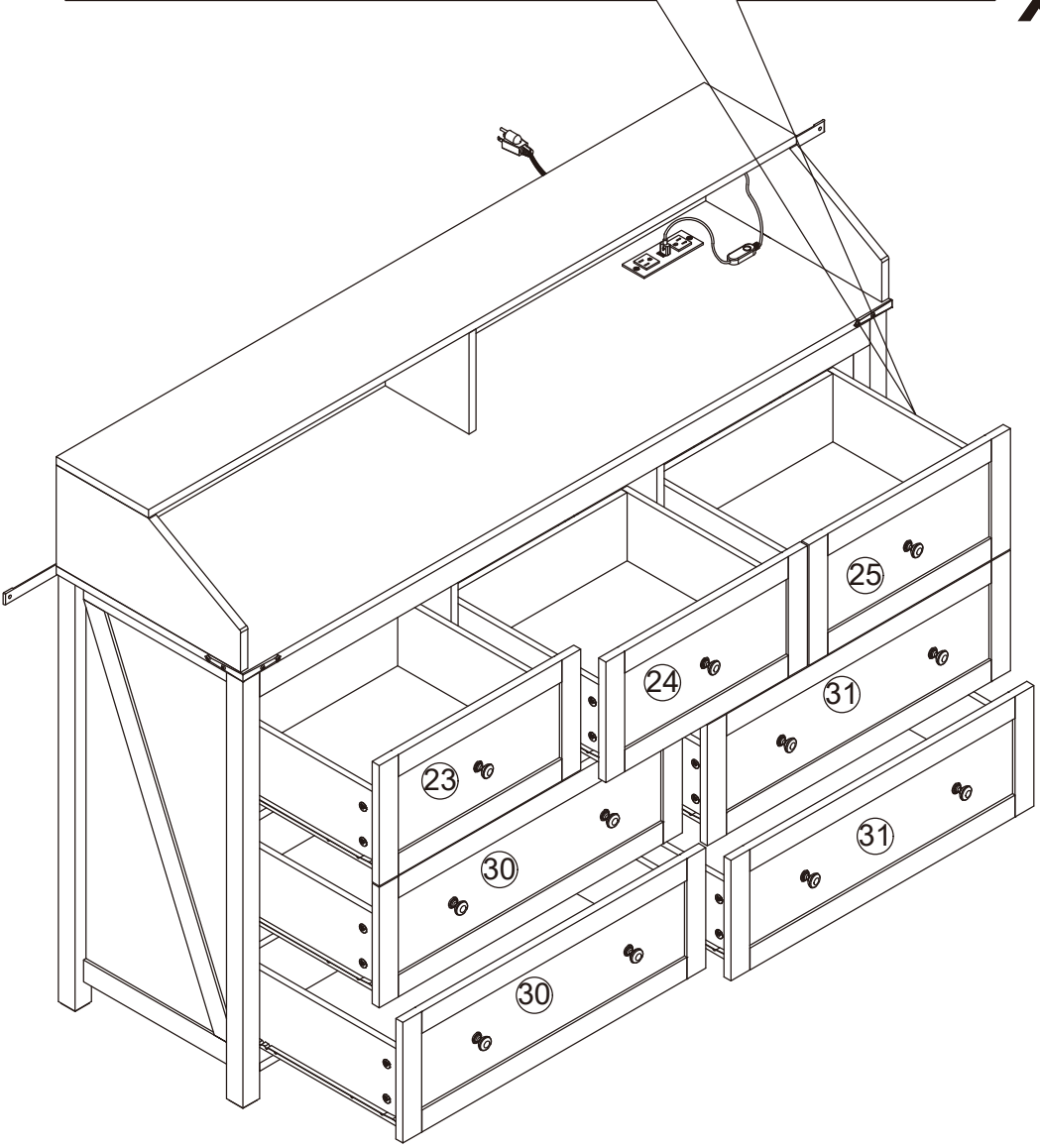
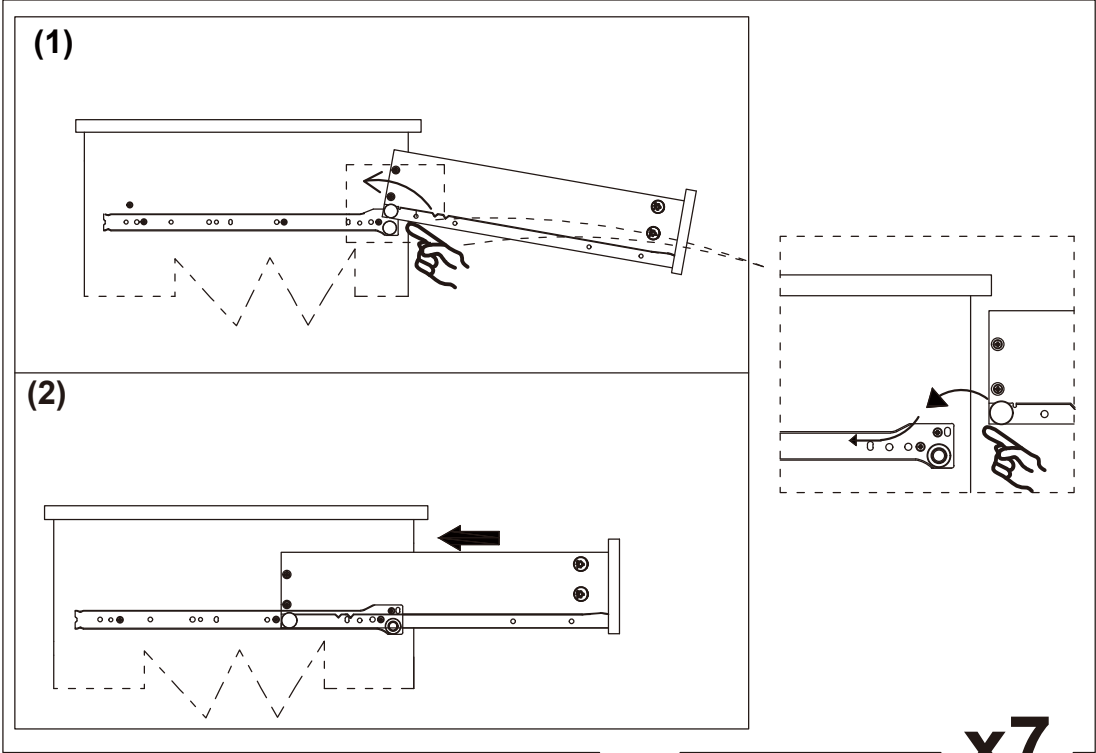

D x2



N x2



O x2

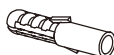

P x2

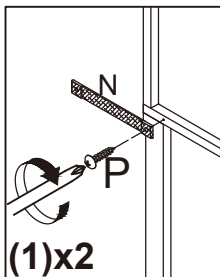

First fix the anti-rewind screw in the reserved hole of the product.

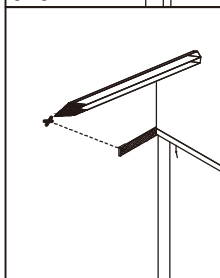

then, use a ruler to measure the approximate height of the product on the wall, and then mark it with a pen.

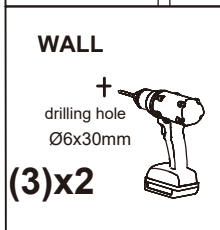

Then use a tape drill to make holes in the wall that are suitable for the product screws.

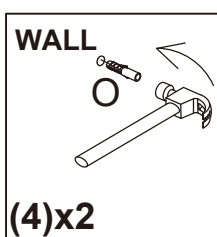

Then, put the expansion bolt into the hole

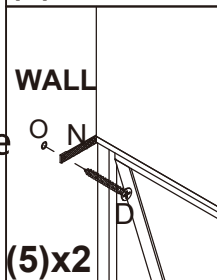

Finally, pass the matching screws through the "anti-rewind" and tighten them to fix them on the wall.

