

Assembly Instruction

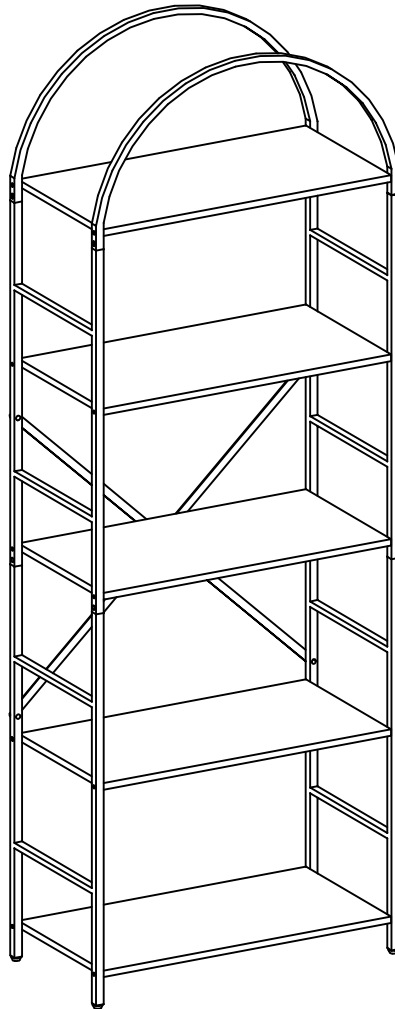

Instruction Manual

Thank you for shopping with us!

We appreciate your purchase and are ready to be at your service!

if you find parts missing, broken, or hard to put together or when you are not satisfied or have any valuable suggestions, please do not hesitate to contact us first!

We will definitely give you a satisfactory solution or answer then!

COMPONENTS ID Nr.

Part Nr.	Qty	Part Nr.	Qty	Part Nr.	Qty
A	5pcs				

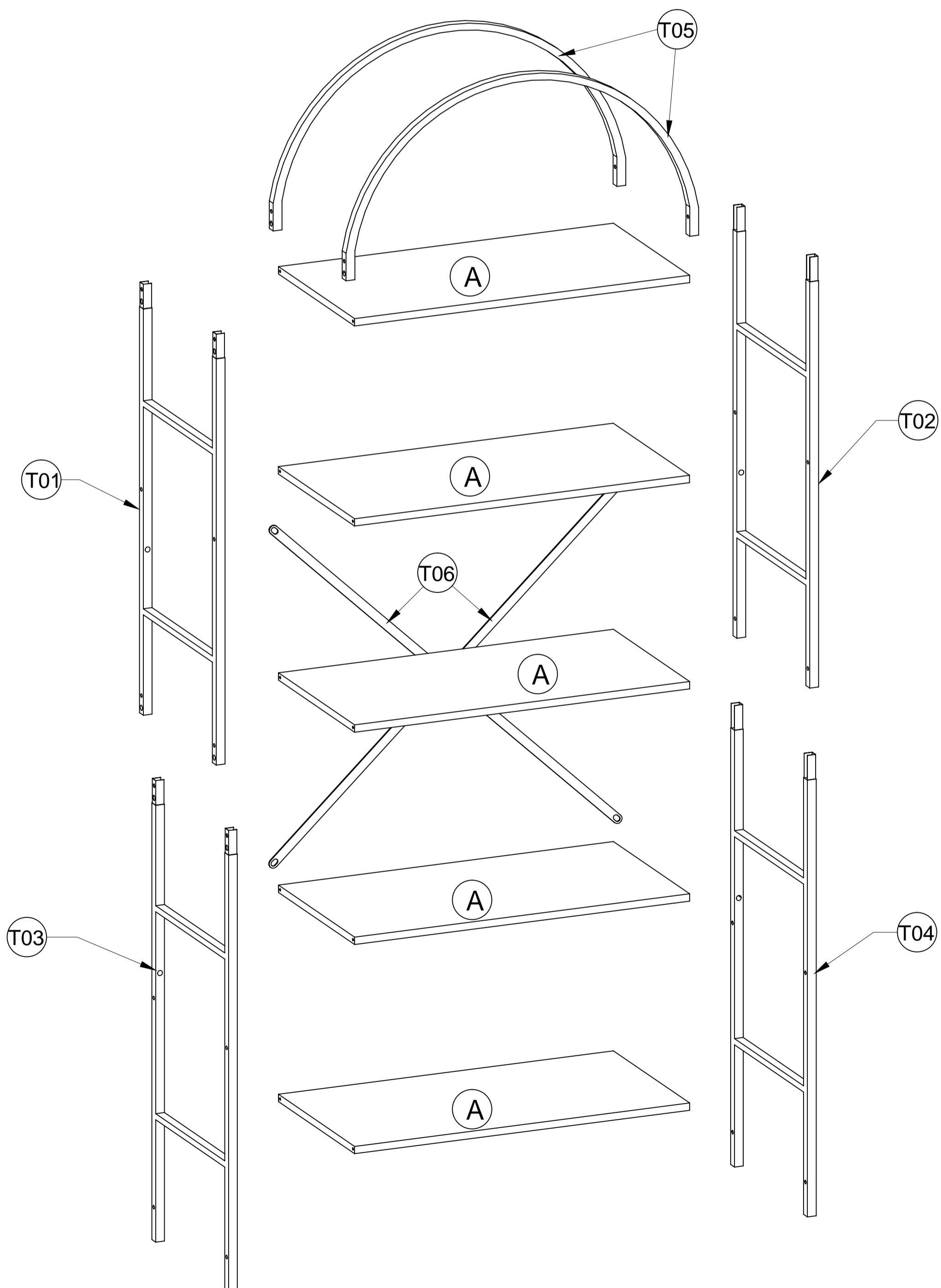

T01	1pcs	T02	1pcs	T03	1pcs
T04	1pcs	T05	2pcs	T06	2pcs

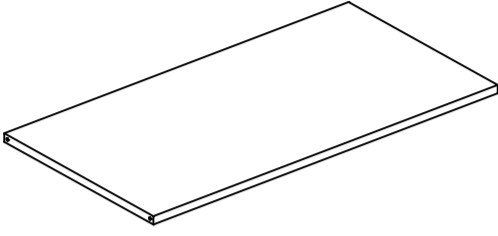
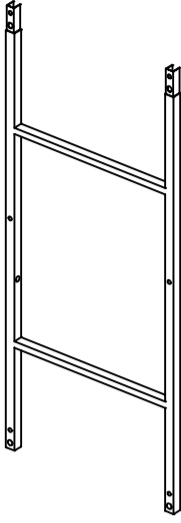
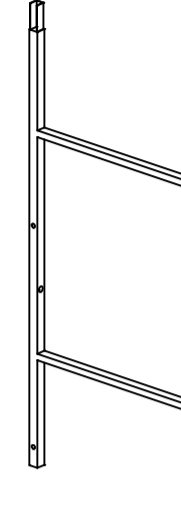
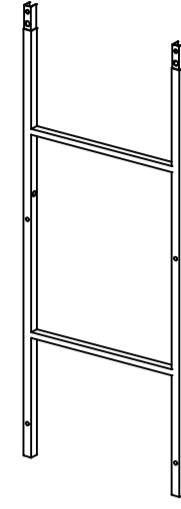
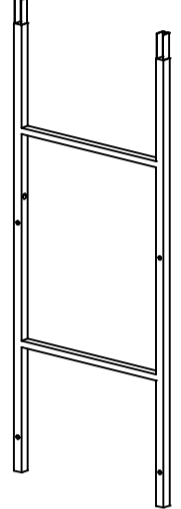
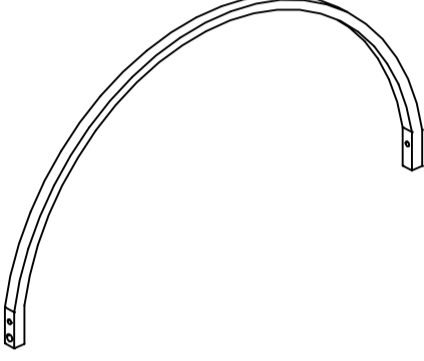
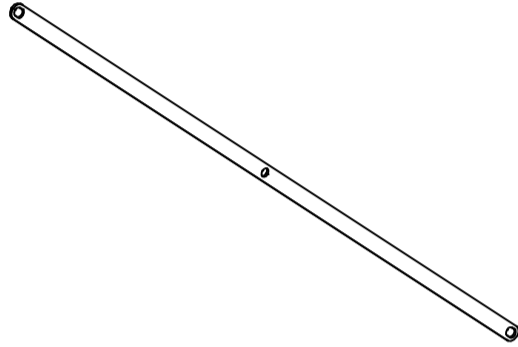

PRODUCT ASSEMBLY

<p>A x 5</p> 	<p>T01 x 1</p> 	<p>T02 x 1</p> 	<p>T03 x 1</p> 
<p>T04 x 1</p> 	<p>T05 x 2</p> 	<p>T06 x 2</p> 	

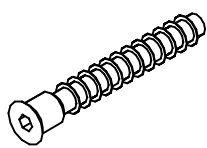
HARDWARE LIST

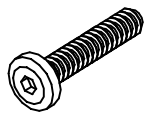
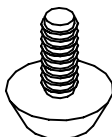
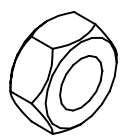
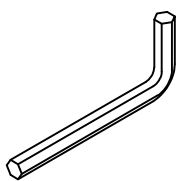
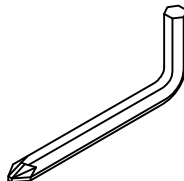
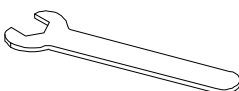
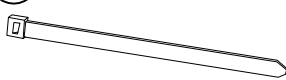
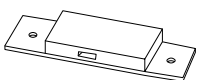
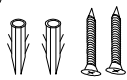
<p>① x 20</p>  <p>D5x50mm</p>	<p>② x 9</p>  <p>M6x10mm</p>	<p>③ x 4</p>  <p>M6X25mm</p>	<p>④ x 4</p>  <p>M6x18mm</p>
<p>⑤ x 5</p>  <p>M6</p>	<p>⑥ x 1</p>  <p>3#</p>	<p>⑦ x 1</p>  <p>4#</p>	<p>⑧ x 1</p>  <p>10MM</p>
<p>⑨ x 2</p>   			

1



Note: Two holes are here at the same side.

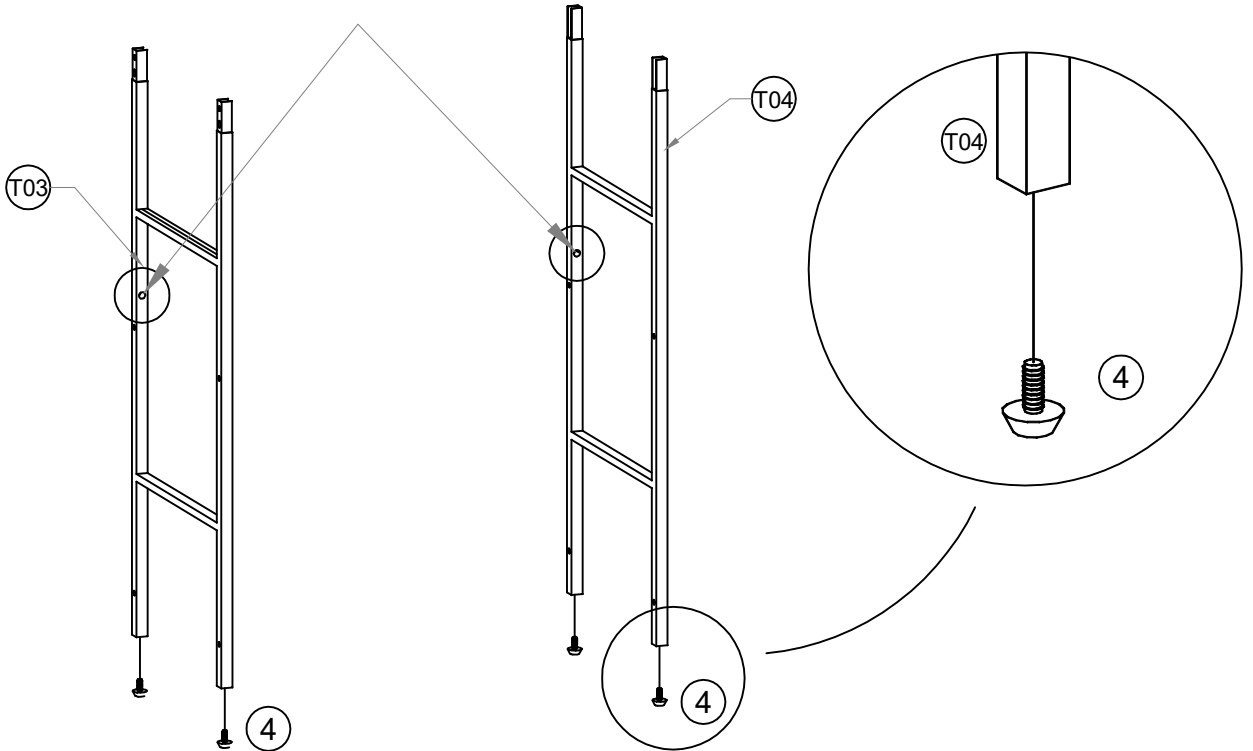

2

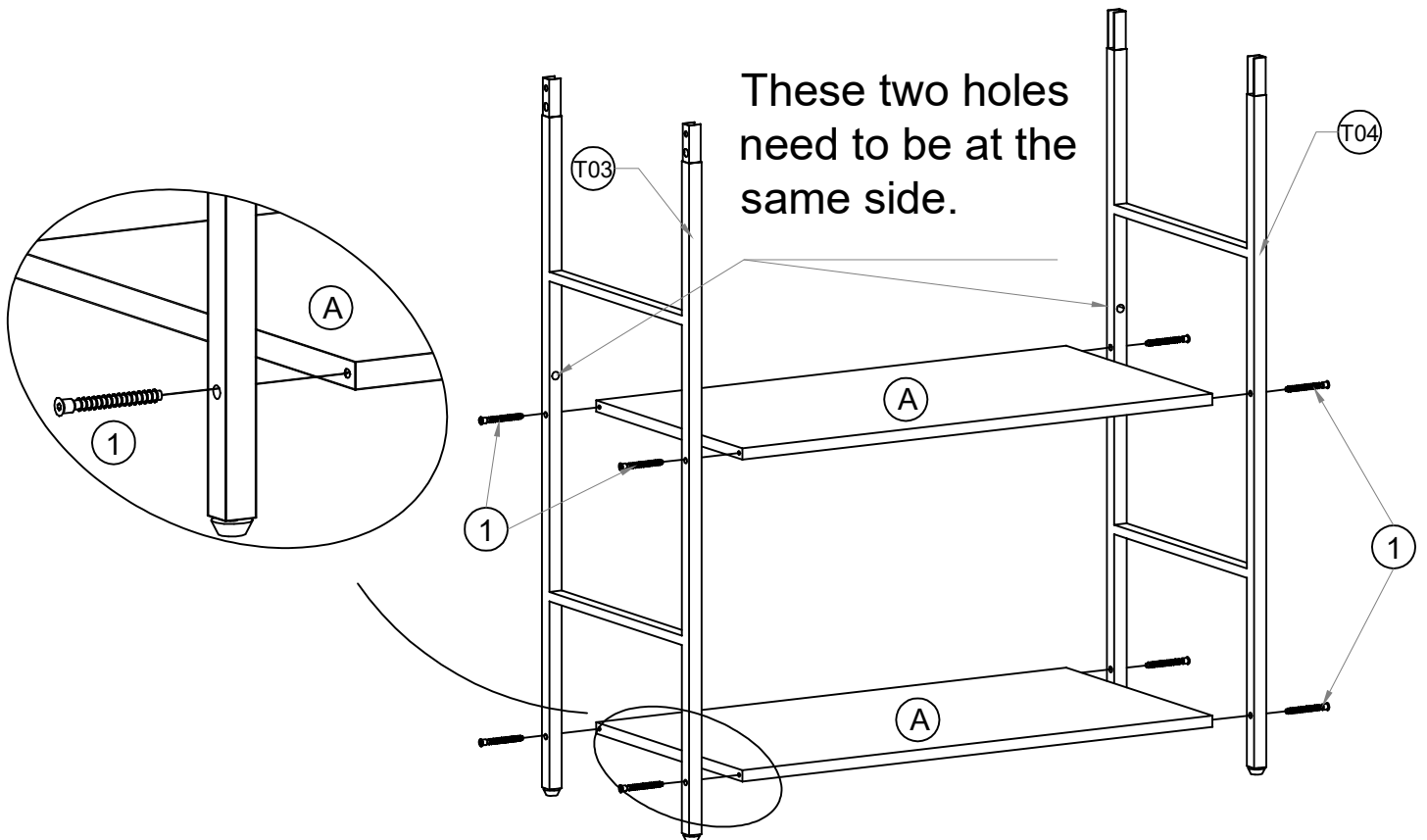
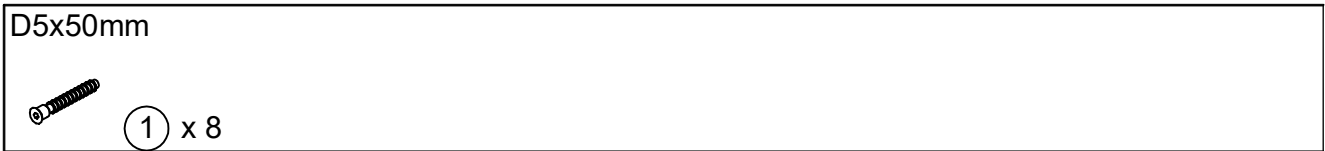

3

M6x10mm



2 x 4

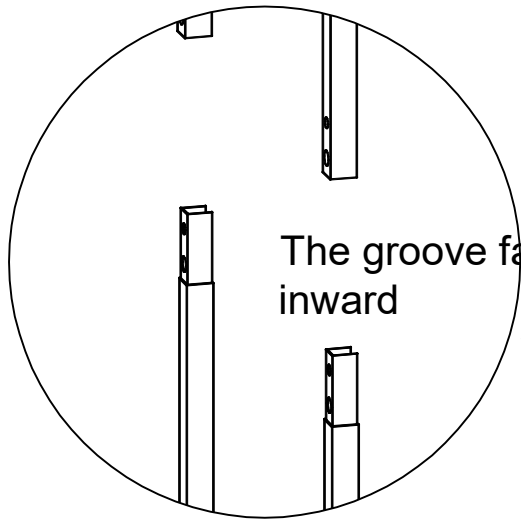

The groove faces inward

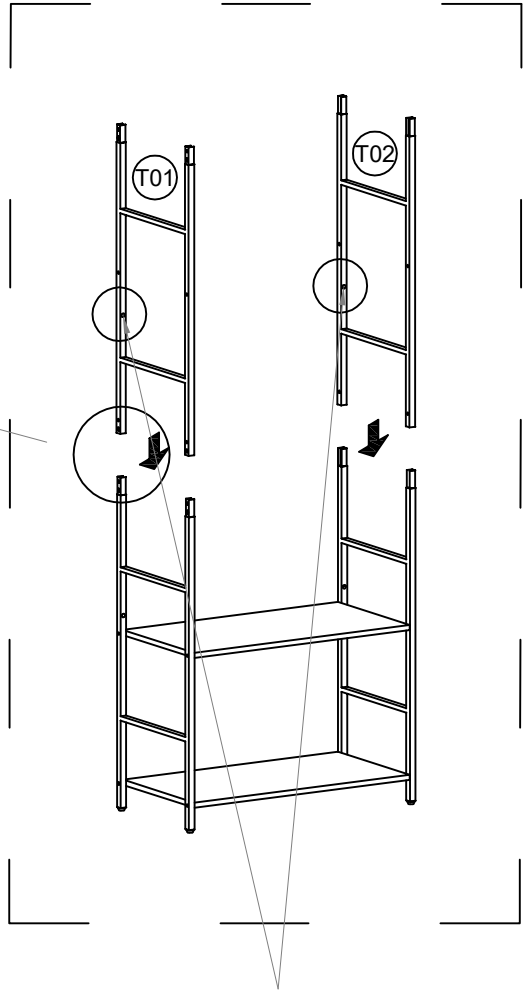

These two holes need to be at the same side.

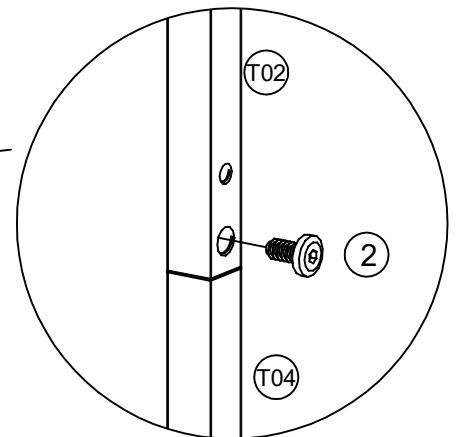
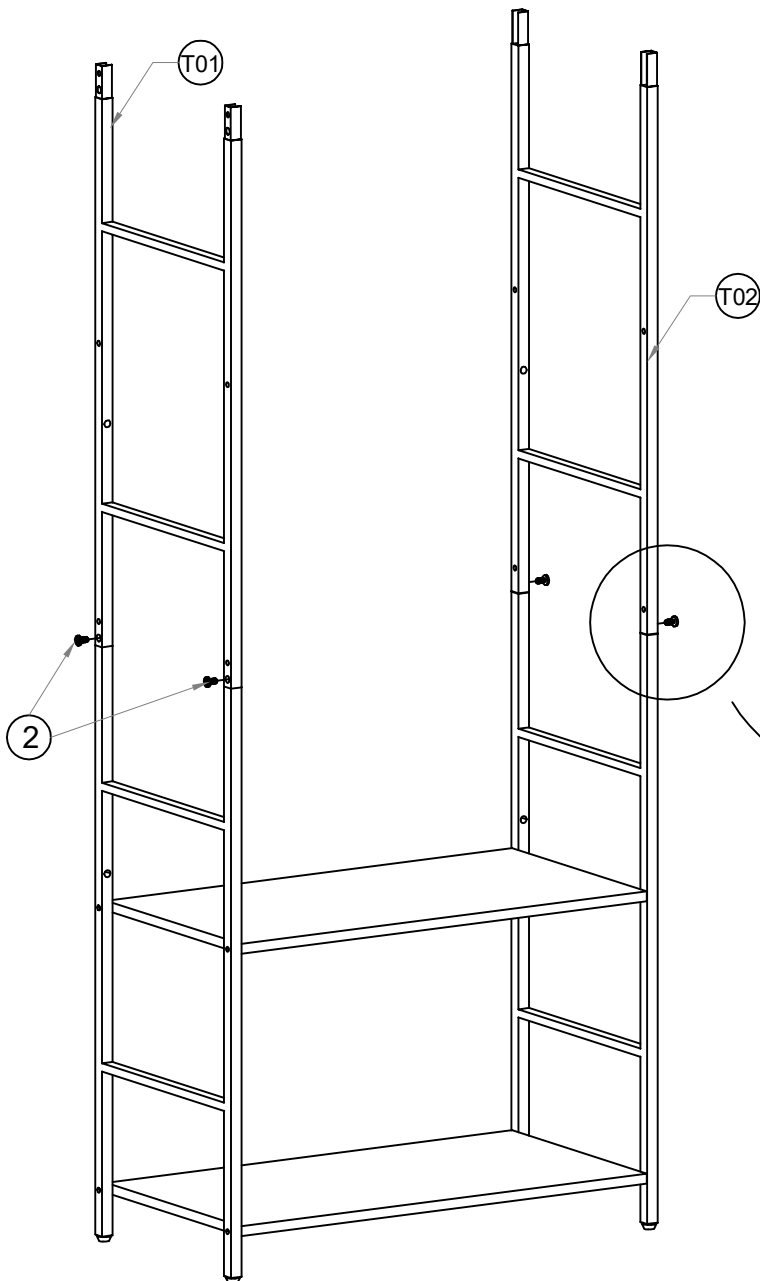

4

D5x50mm



① x 8

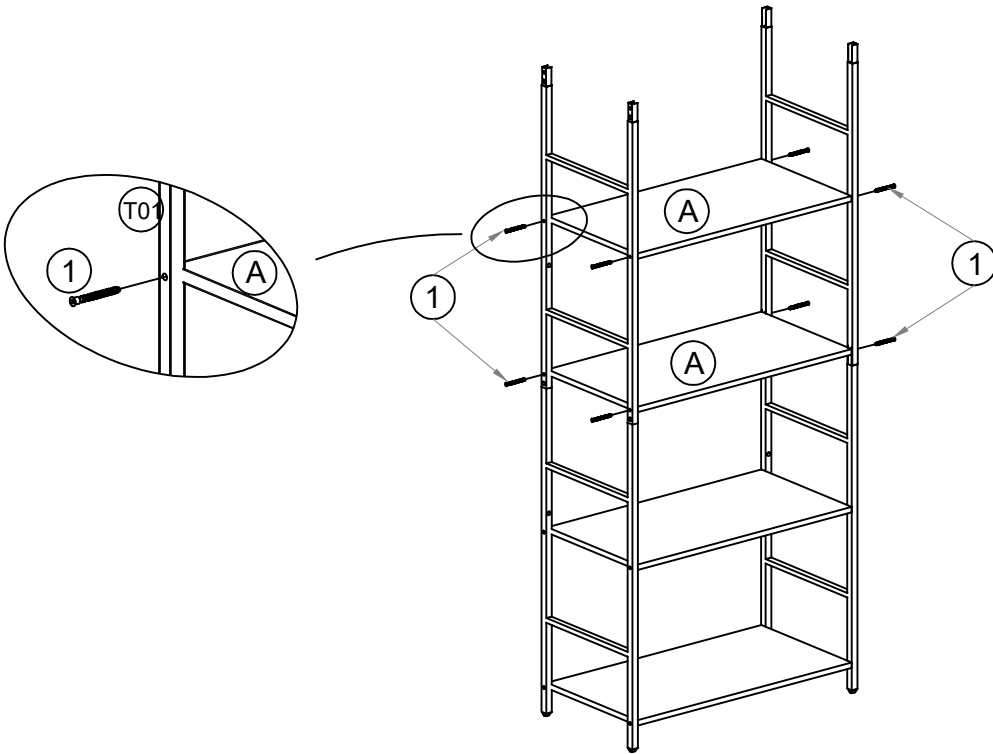

5

M6x10mm



② x 4

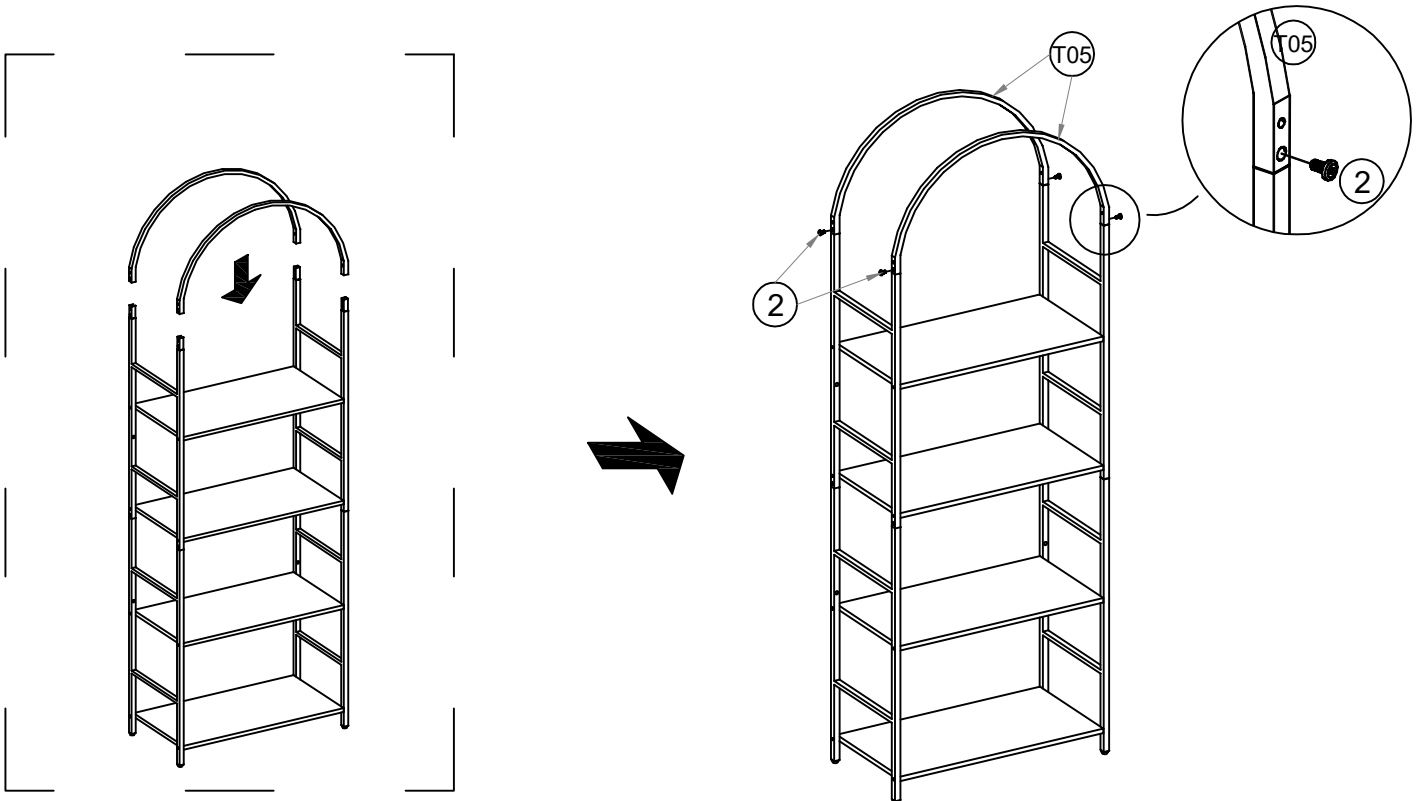

6

D5x50mm



① x 4

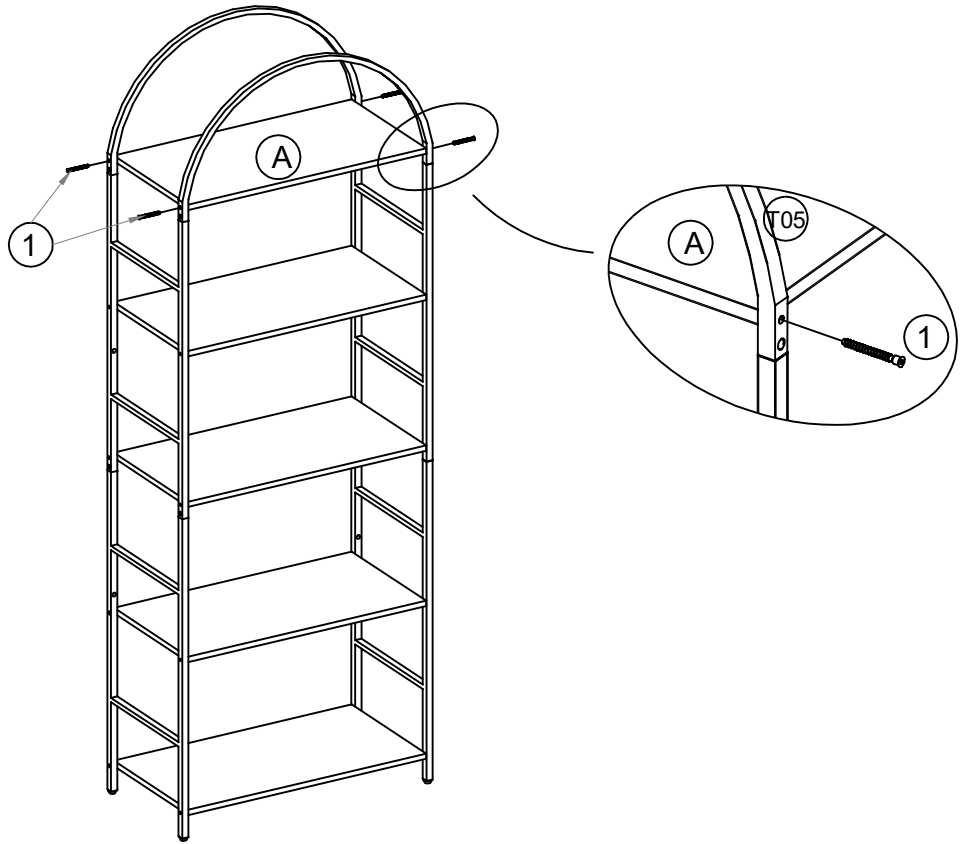

7

M6x10mm

M6x25mm

M6



② x 1



③ x 4



⑤ x 5

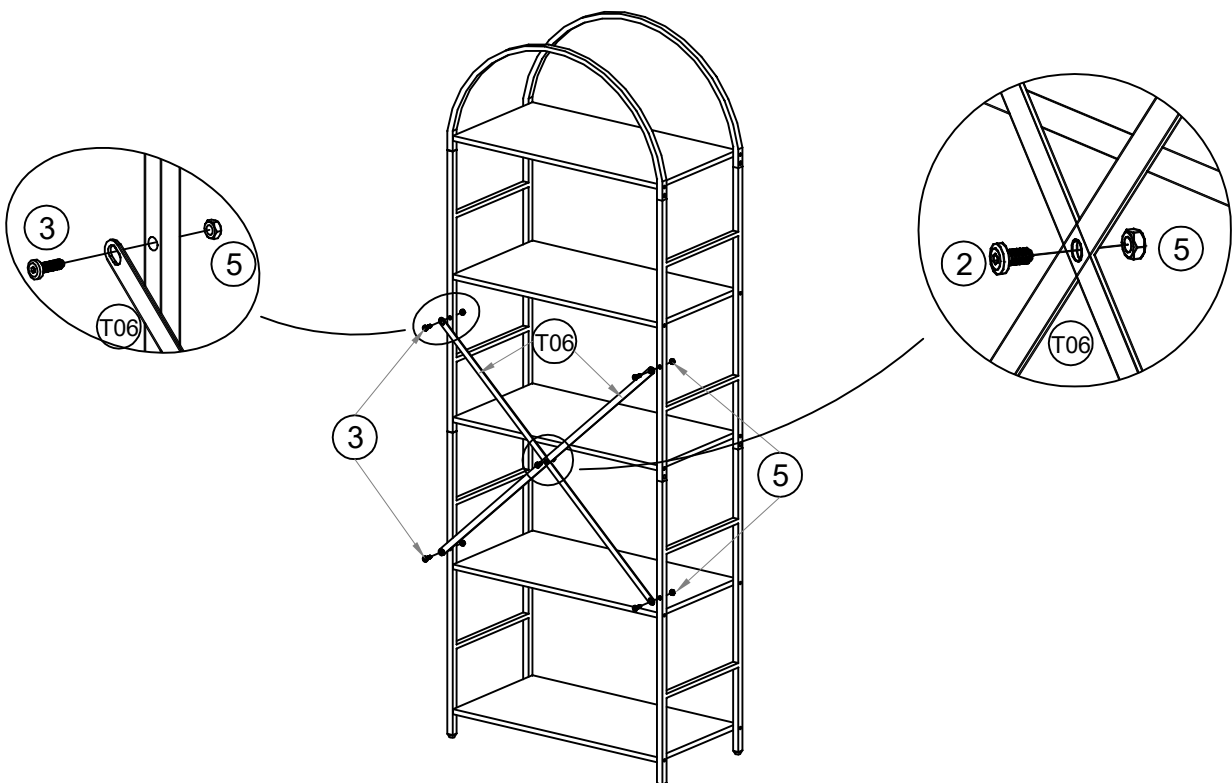

8

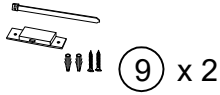

WALL

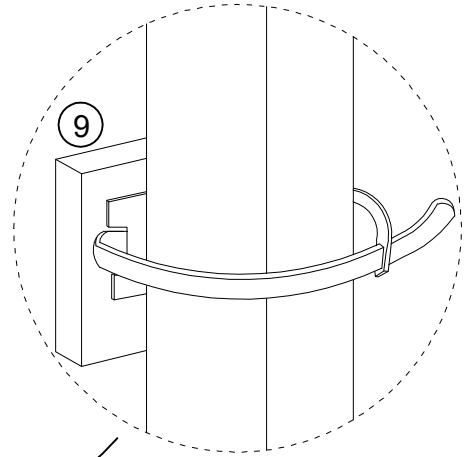
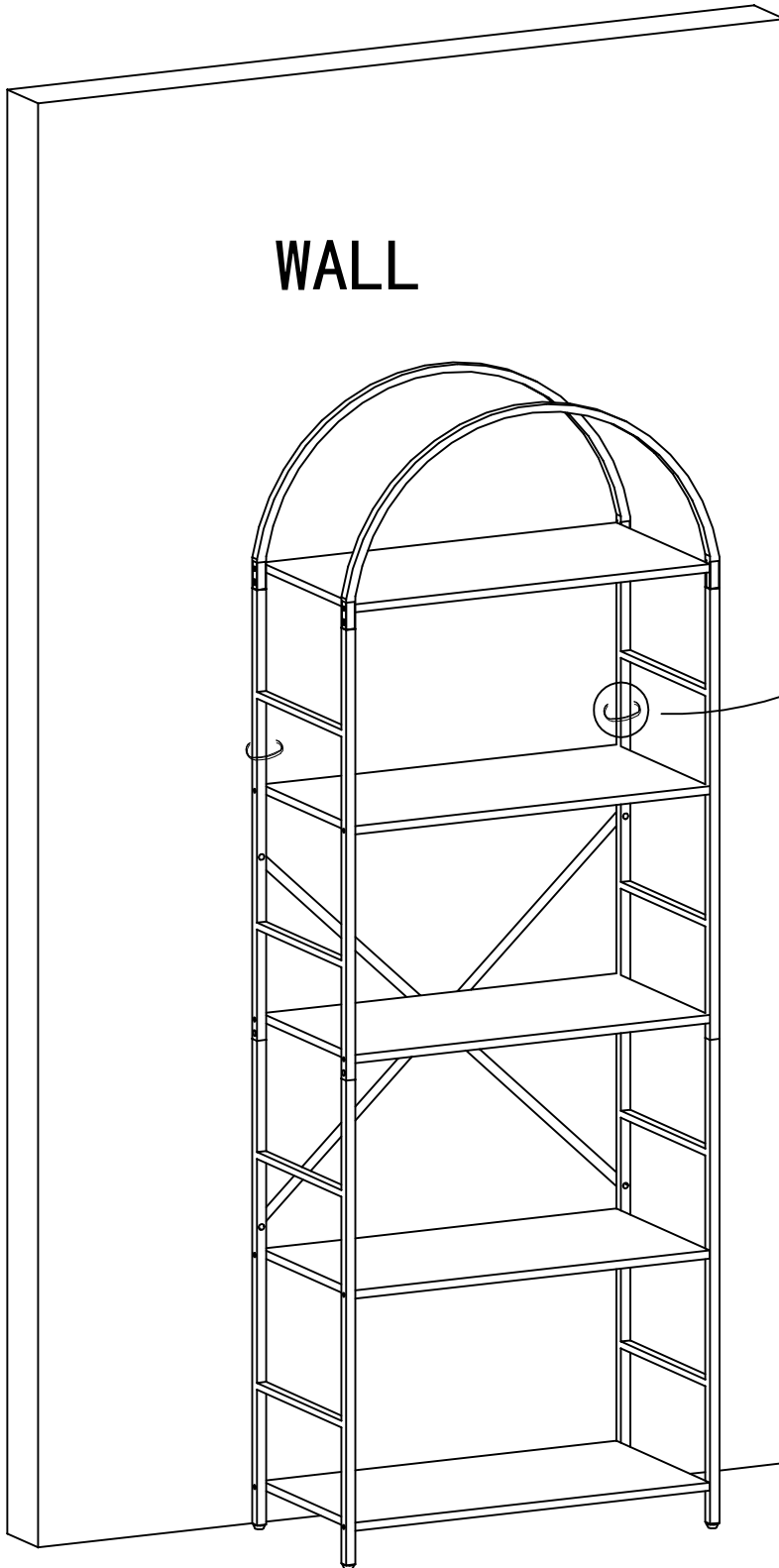
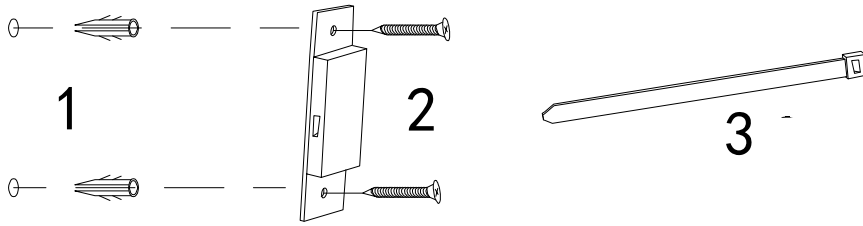

9

Finished assembly

