

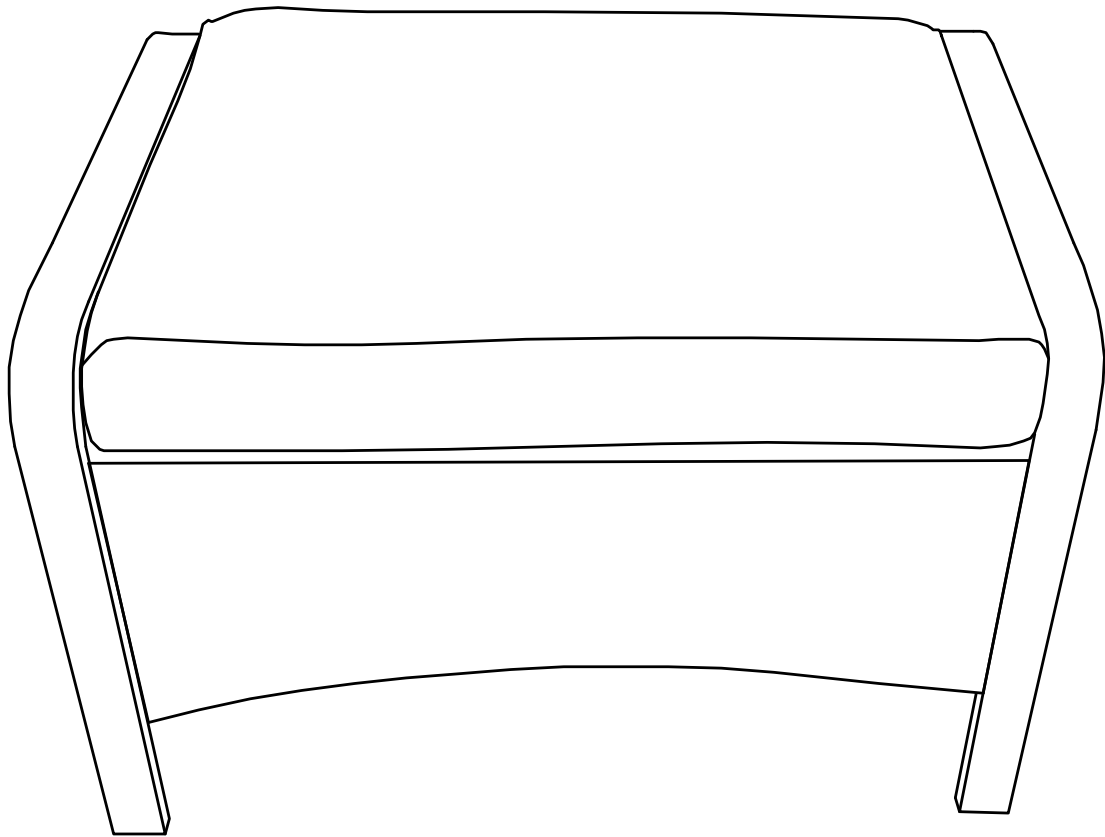





# Assembly Instructions

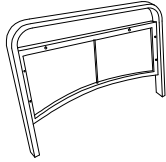

**\*Don't fully tighten all the bolts till the very end!**

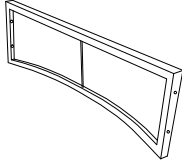
## PRE-ASSEMBLY PREPARATION:

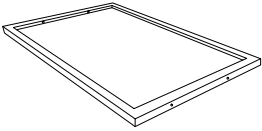
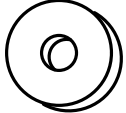
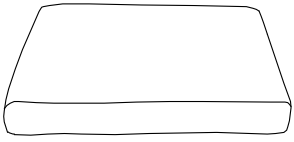
- Please read through the instructions before beginning assembly.
- Clear out the space for assembly and lay out all of the parts based on the Parts List, extra room will allow you to easily determine if all the pieces are present.
- Keep small parts and pieces away from children until fully assembled.

Part no.	Part	QTY	Image	Part no.	Part	QTY	Image
A	Leg panel	2		E	Bolt M6*30mm	8	
B	Side panel	2		F	Bolt M6*40mm	4	
C	Seat panel	1		G	Washer M6	12	
D	Cushion	1		H	Allen wrench	1	

**Step 1:** Attach parts B to parts A with 8pcs bolts E and 8pcs washers G, using Allen wrench H. Note: Don't fully tighten the bolts.

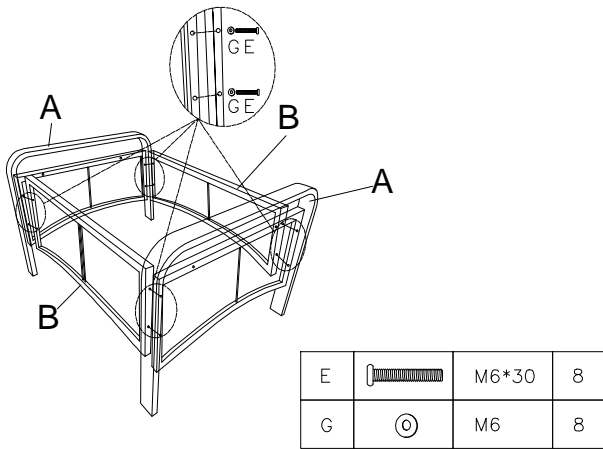

**Step 2:** Attach part C to parts A with 4pcs bolts F and 4pcs washers G, using Allen wrench H. Put the cushion D onto the seat. Assembly is now complete and the product is ready for use.

