

FULL BED ASSEMBLY INSTRUCTIONS

BOX#1

A. HEADBOARD 1PC

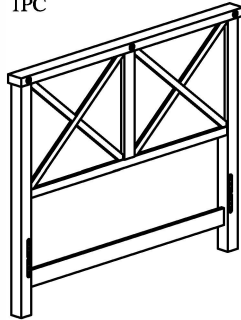

BOX#2

B. FOOTBOARD 1PC

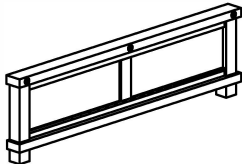

BOX#3

C. SIDERAILS 2PCS

D. BED SLATS 5PCS



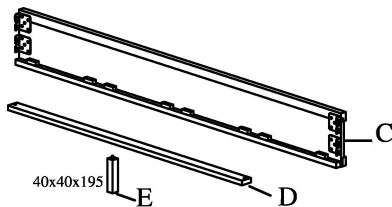

E. LEG SUPPORTS 5PCS

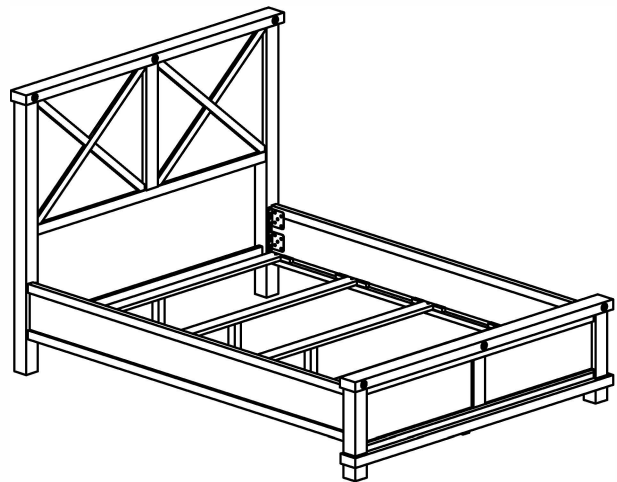

FULL BED ASSEMBLED



HARDWARE ARE PACKED IN BOX

1	ALLEN BOLT M8 x 30 MM	16 PCS	2	WASHER M8	16 PCS	3	ALLEN KEY (4MM)	02 PCS	4	SCREW M4 x 30MM	10 PCS
											

TOOL REQUIRED

PHILLS HEAD SCREW
DRIVER NOT PROVIDED

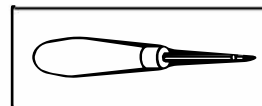

STEP 1:

FIX ONE OF THE SIDERAILS (C) TO THE HEADBOARD (A) USING ALLEN KEY (3) AND ALLEN BOLT (1) AND WASHERS (2).
DO NOT TIGHTEN BOLTS COMPLETELY UNTIL ASSEMBLY IS COMPLETED

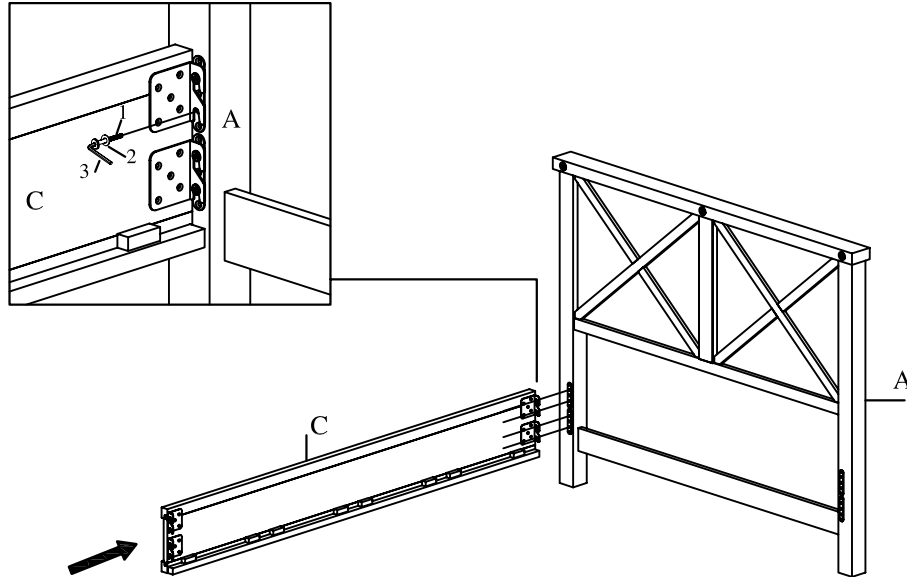

STEP 2:

FIX THE OTHER END OF THE SIDERAILS (C) TO THE FOOTBOARD (B) USING ALLEN KEY (3) AND ALLEN BOLT (1) AND WASHERS (2).
DO NOT TIGHTEN BOLTS COMPLETELY UNTIL ASSEMBLY IS COMPLETED

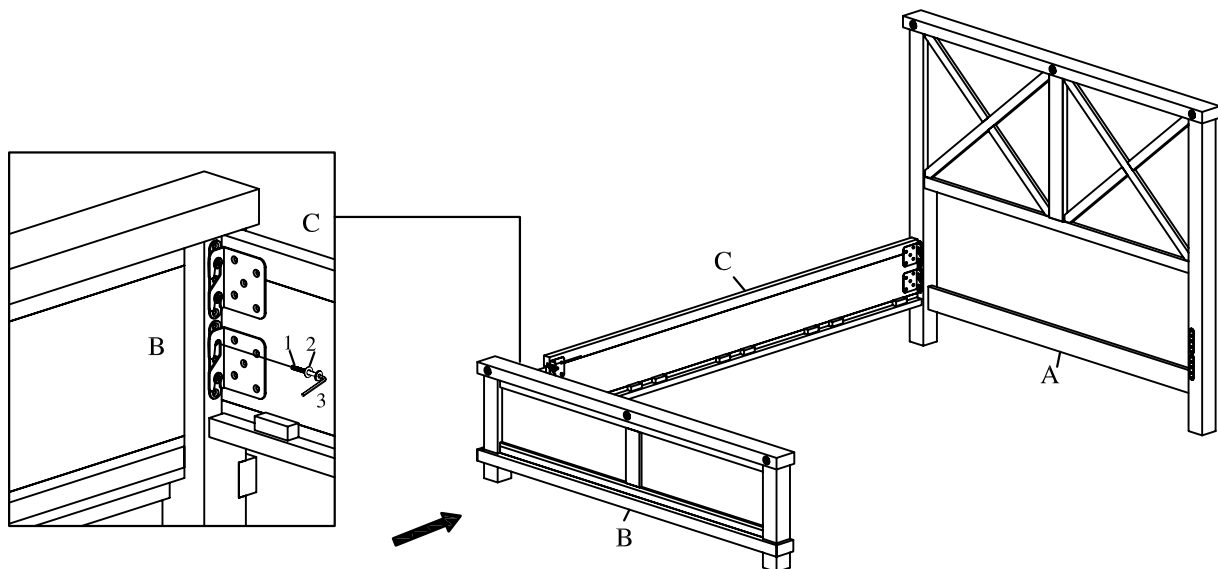

STEP 3:

FIX ONE OF THE SIDERAILS (C) TO THE HEADBOARD (A) AND FOOTBOARD (B) USING ALLEN KEY (3) AND ALLEN BOLT (1) AND WASHERS (2). DO NOT TIGHTEN BOLTS COMPLETELY UNTIL ASSEMBLY IS COMPLETED

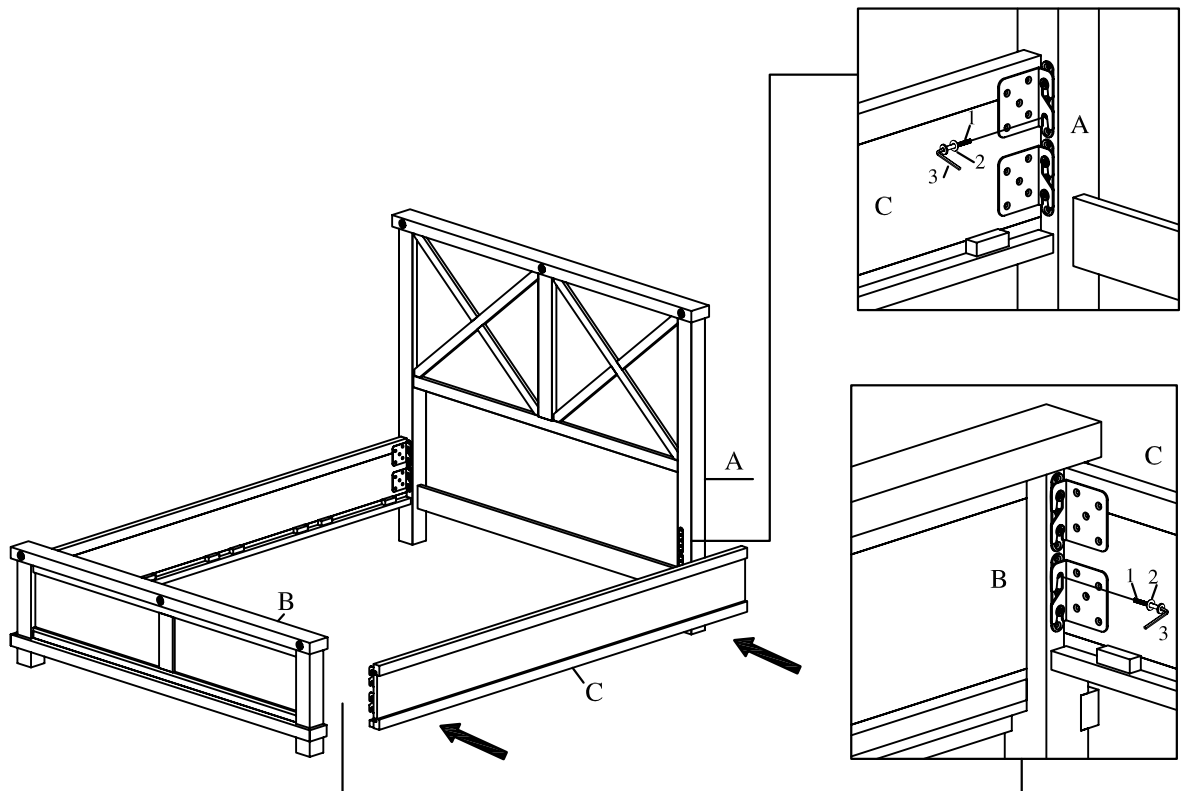

STEP 4:

ATTACH THE LEG (E) TO THE BED SLATS (D)

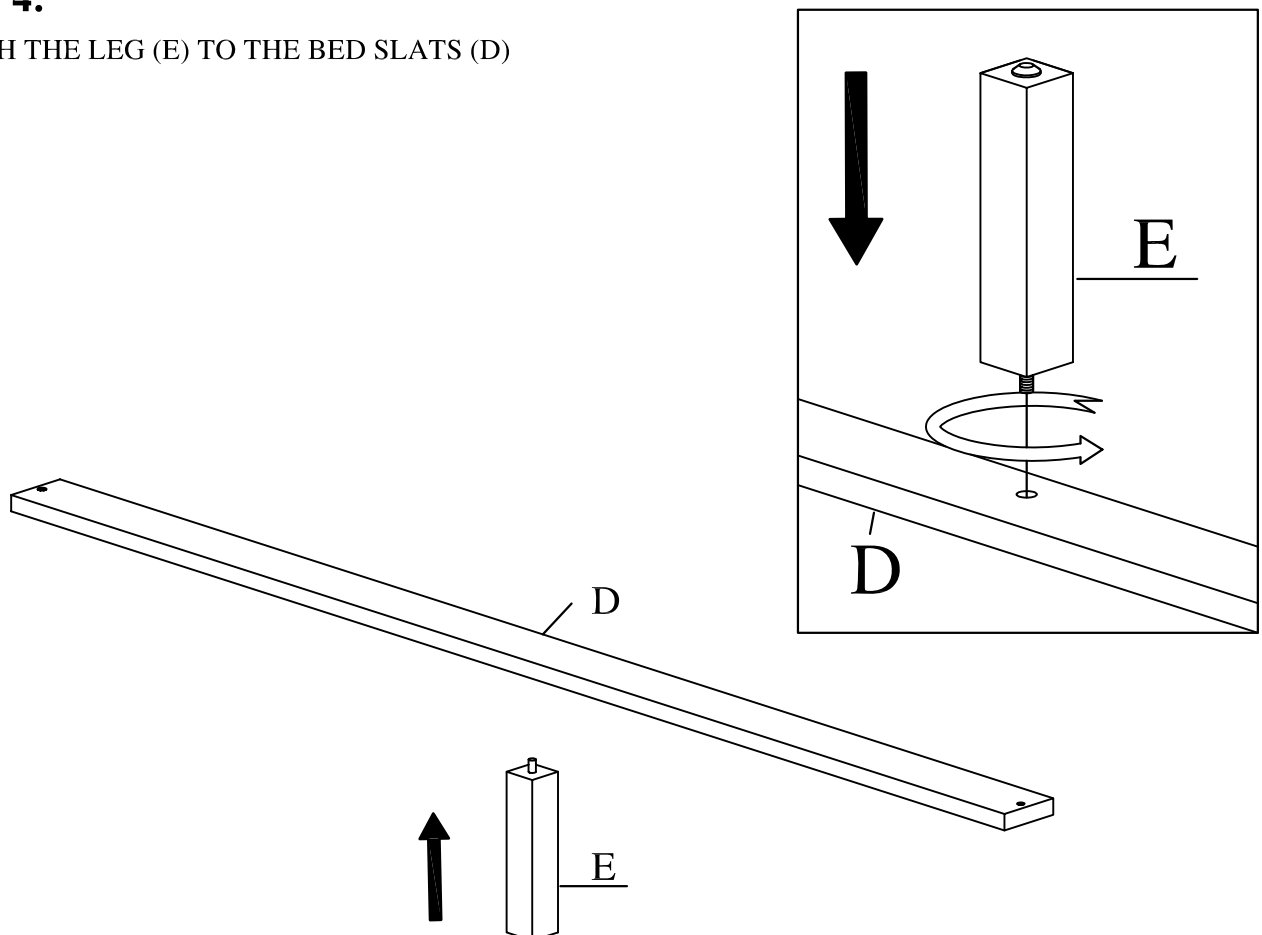

STEP 5:

FOLLOW THE ILLUSTRATION TO PLACE FIVE BED SLATS (D) ON THE BED FRAME. AND SECURE THE BED SLATS (D) USING WOOD SCREWS (4). USE THE PILOT HOLES ON THE SIDERAILS (C) AS YOUR REFERENCE FOR EASY ASSEMBLY.

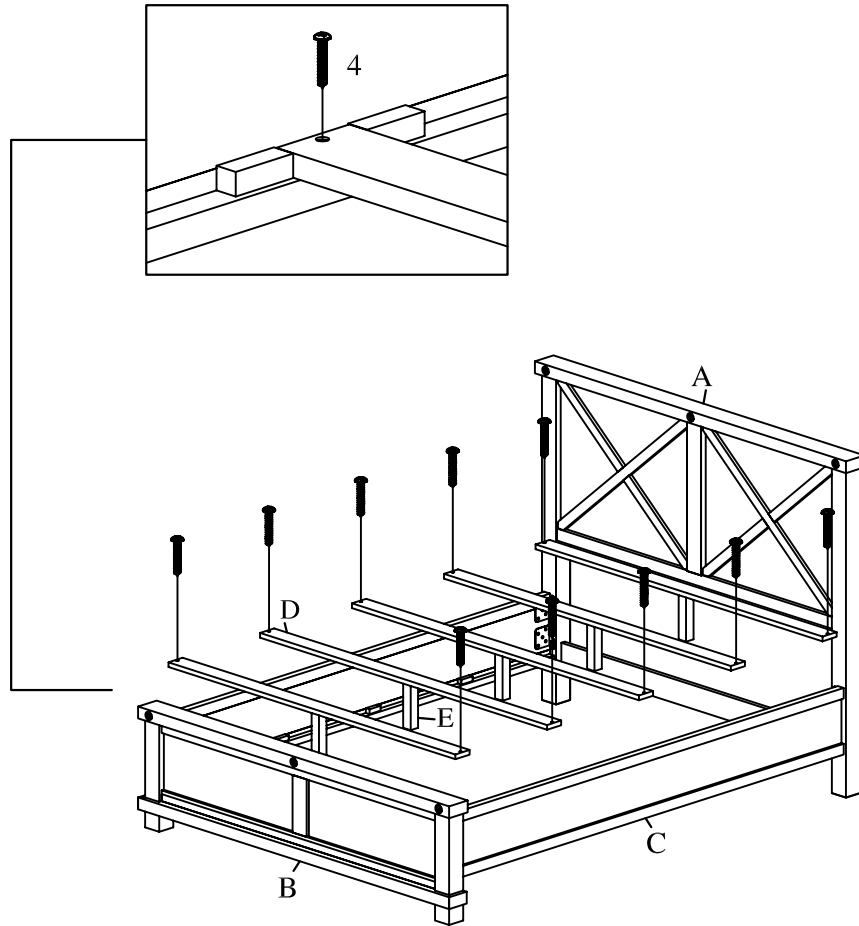

STEP 6:

ASSEMBLY COMPLETE

