

Assembly Instruction

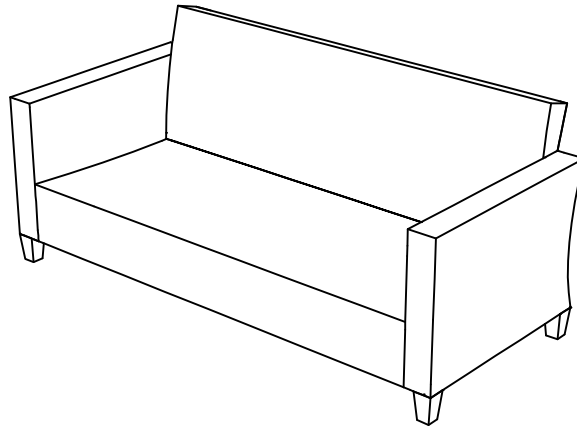













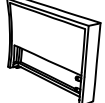

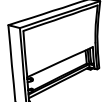
Advice:

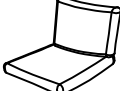
1. Power tools are suggested to be used during installation.
2. More than one person may be required to assemble this product.
3. The best advice is not tightening up any screws until the whole piece is assembled. If having difficulty aligning holes, loosen the screws already installed and readjust the armrest.
4. To avoid mess-up or mismatch, please use the hardware of each box to install the furniture in the same box.

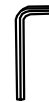

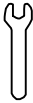
3-Seat Sofa

Parts List

Part Number	Picture	Description	QTY	Part Number	Picture	Description	QTY
S-A		Sofa Back	1	I		Screw (M6*60)	2
S-B		Sofa Seat	1	J		Screw (M6*95)	2
S-C		Left Arm	1	K		Washer (M6)	22
S-D		Right Arm	1	L		Nut (M6)	10
S-E		Seat and Back Cushion	3	M		Nut (M8)	4
F		Sofa Leg	4	N		Allen Key	1
G		Screw (M6*35)	4	O		Wrench (M8)	1
H		Screw (M6*75)	4	P		Wrench (M6)	1
				Q		Washer (M8)	4

STEP 1

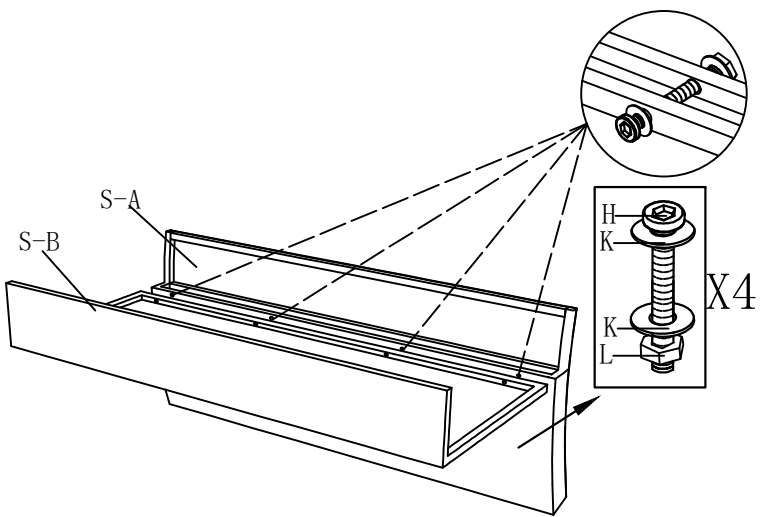

STEP 2

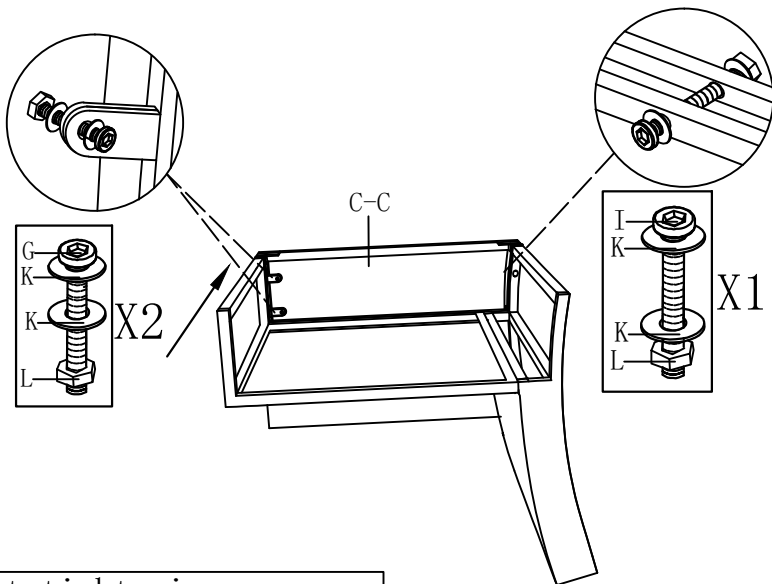

The best advice is not tightening up any screws until the whole piece is assembled.

STEP 3

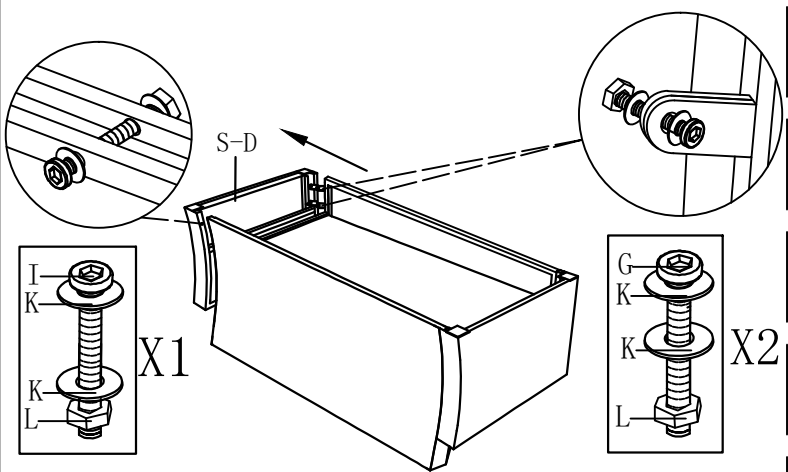

STEP 4

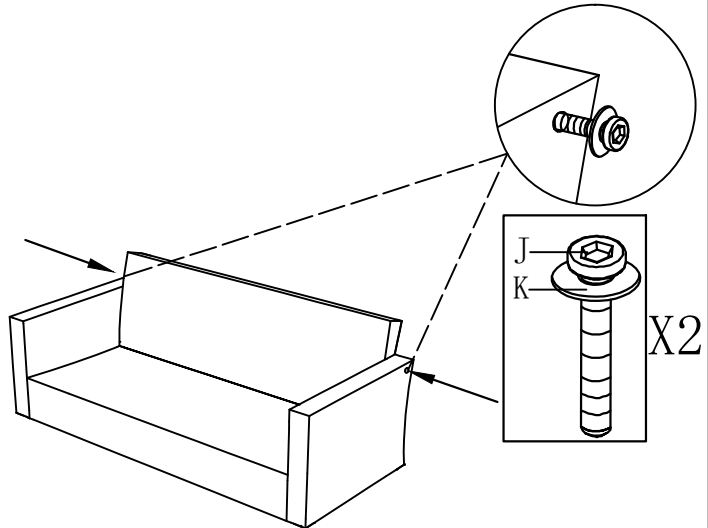

STEP 5

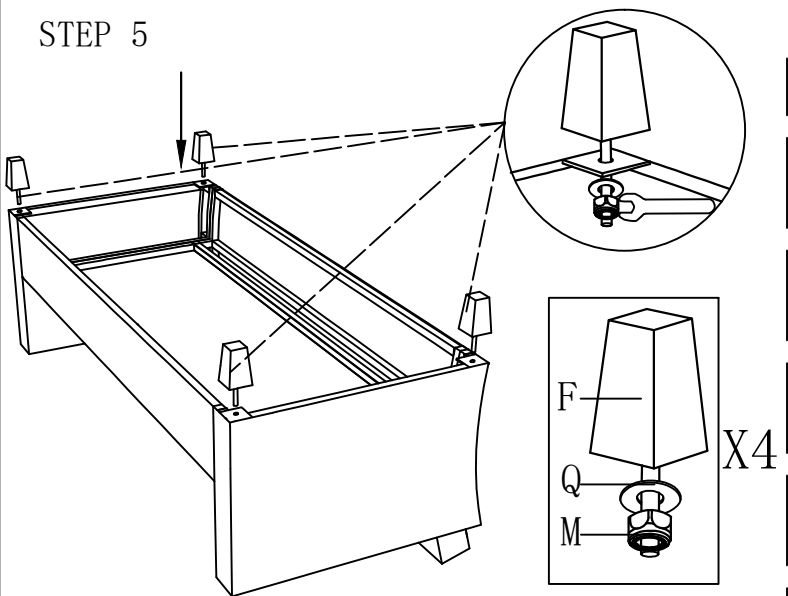

FINISH

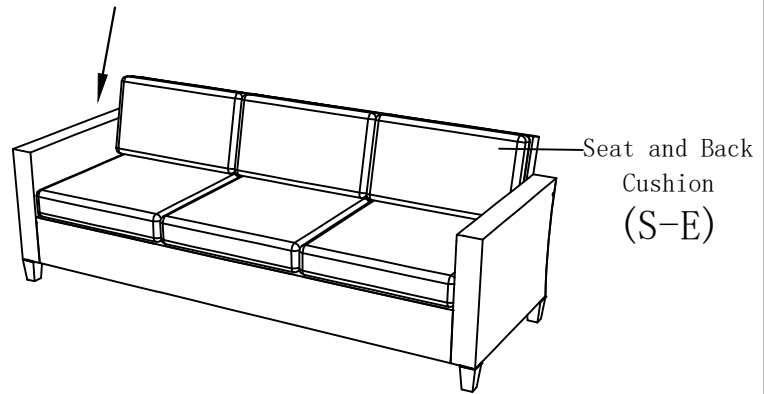

It is recommended to tighten the anti-slip screws with your own M8 wrench.

Please tap the cushions and wait 48 to 72 hours to fully rebound

Assembly Instruction





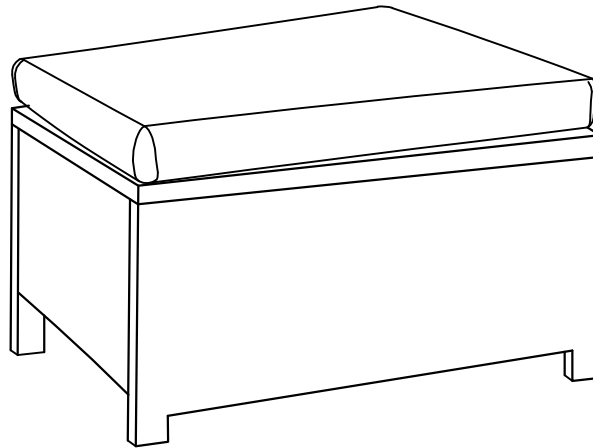

Advice:

1. Power tools are suggested to be used during installation.
2. More than one person may be required to assemble this product.
3. The best advice is not tightening up any screws until the whole piece is assembled. If having difficulty aligning holes, loosen the screws already installed and readjust the armrest.
4. To avoid mess-up or mismatch, please use the hardware of each box to install the furniture in the same box.

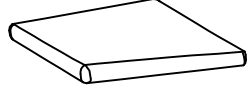

Ottoman

Parts List

Part Number	Picture	Description	QTY
0-A		Top Panel	1
0-B		Side Panel with Legs	2
0-C		Side Panel without Legs	2
0-D		Cushion	1
E		Washer (M6)	14
F		Screw (M6*35)	14
G		Allen Key	1

STEP 1

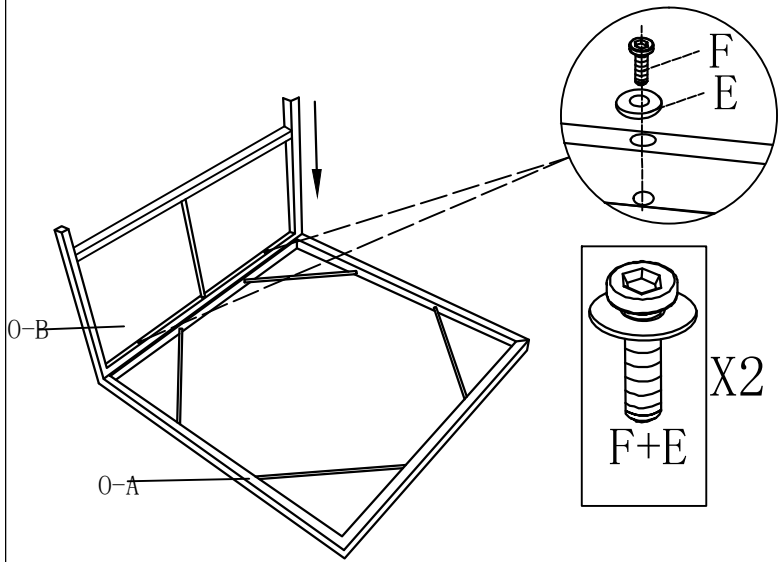

STEP 2

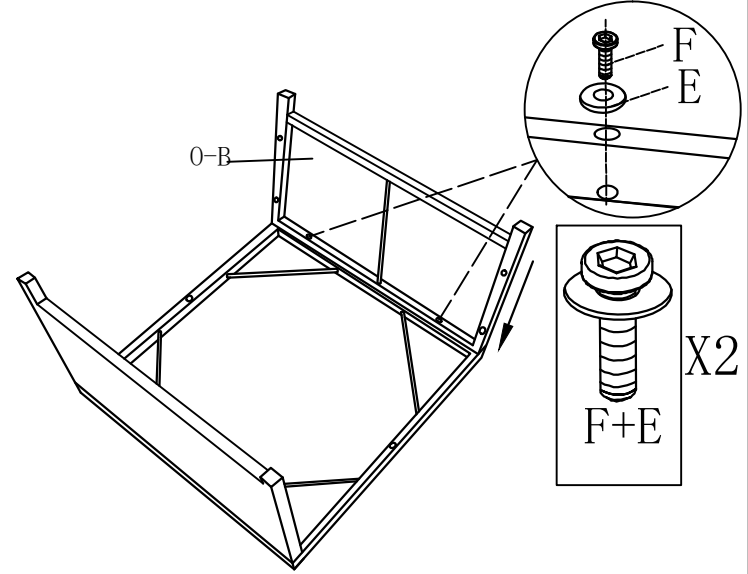

The best advice is not tightening up any screws until the whole piece is assembled.

STEP 3

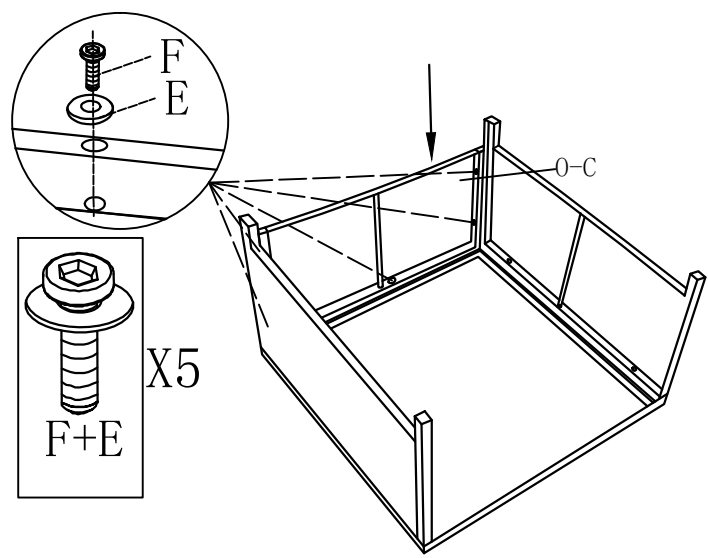

STEP 4

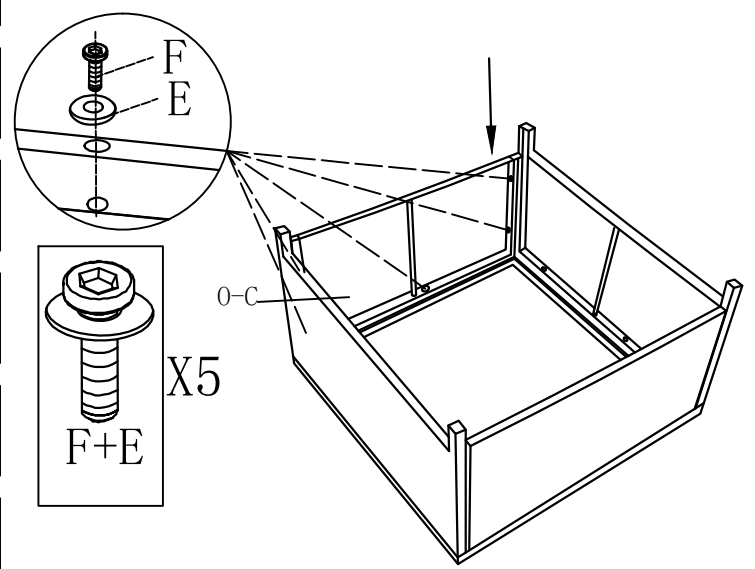

FINISH

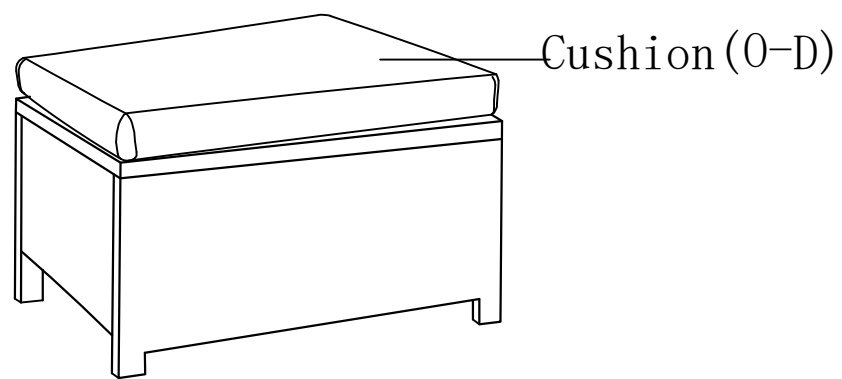

Please tap the cushions and wait 48 to 72 hours to fully rebound

Assembly Instruction



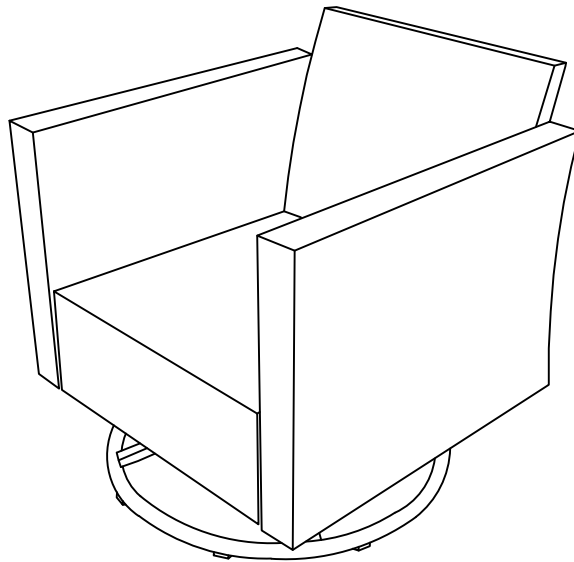

Advice:



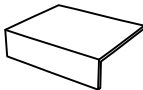
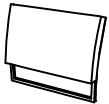

1. Power tools are suggested to be used during installation.
2. More than one person may be required to assemble this product.
3. The best advice is not tightening up any screws until the whole piece is assembled. If having difficulty aligning holes, loosen the screws already installed and readjust the armrest.
4. To avoid mess-up or mismatch, please use the hardware of each box to install the furniture in the same box.

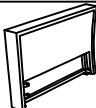

Single Swivel Chair

Parts List

Part Number	Picture	Description	QTY
SC-A		Chair Seat	1
SC-B		Chair Back	1
SC-C		Left Arm	1
SC-D		Right Arm	1
E		Screw (M6*35)	4
F		Screw (M6*60)	4

Part Number	Picture	Description	QTY
G		Screw (M6*95)	2
H		Washer (M6)	18
S		Nut (M6)	8
T		Wrench (M6)	1
U		Allen Key	1

STEP 1

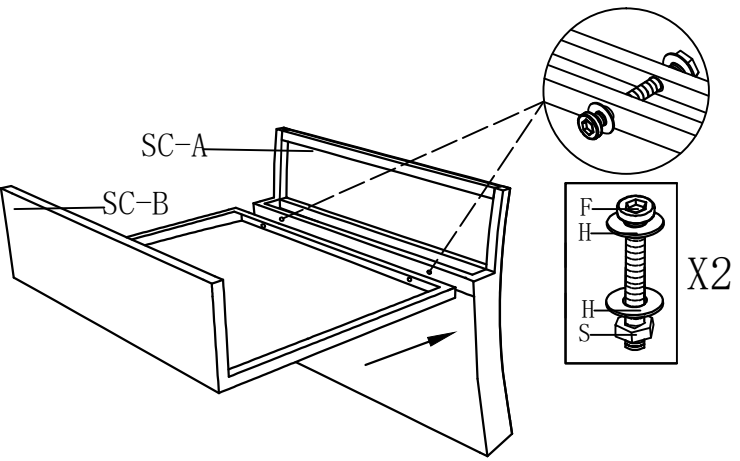

STEP 2

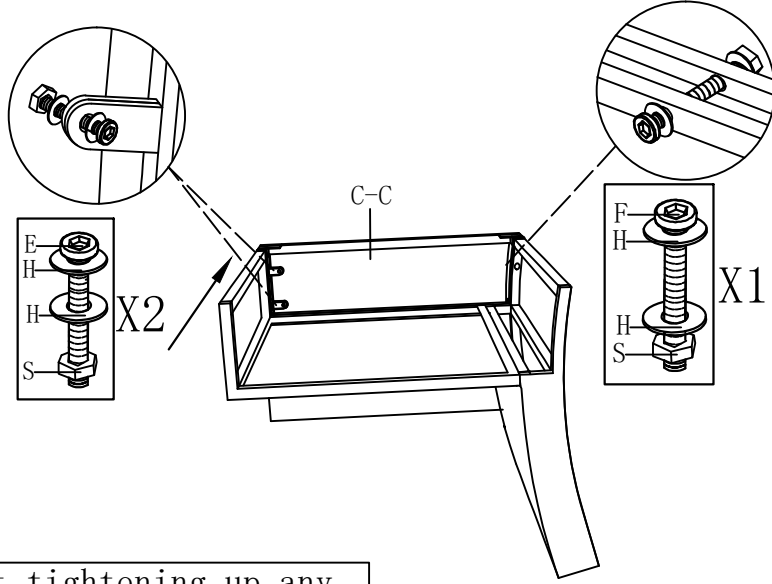

The best advice is not tightening up any screws until the whole piece is assembled.

STEP 3

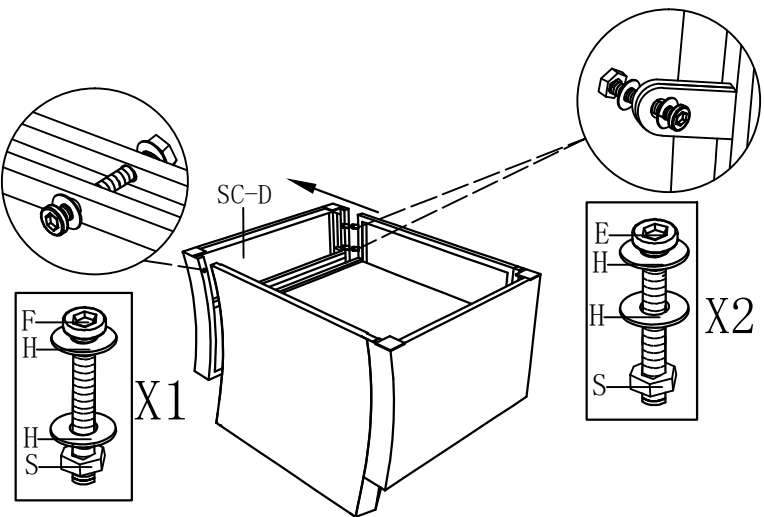

STEP 4

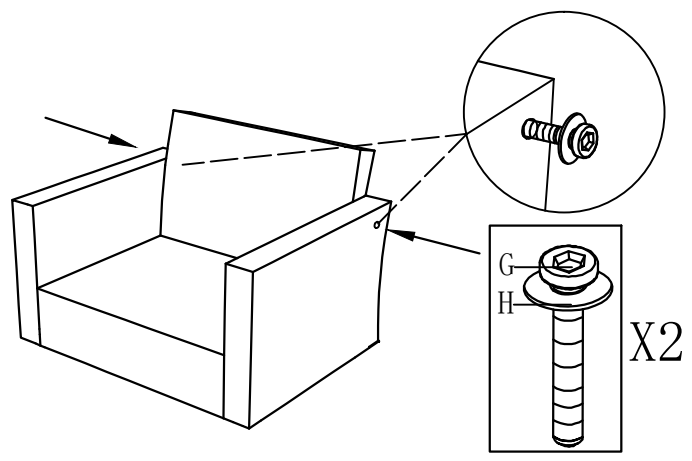

FINISH

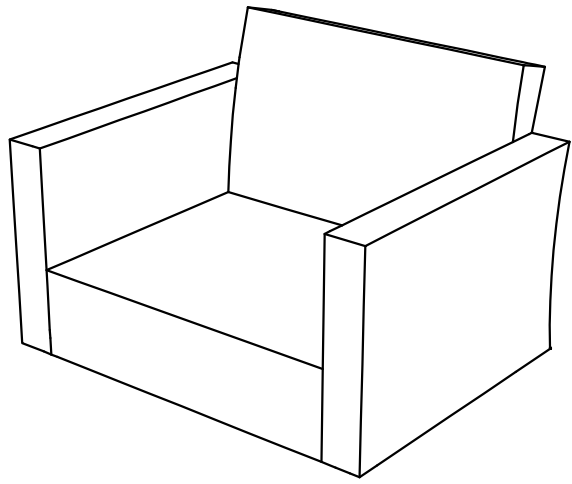

Assembly Instruction



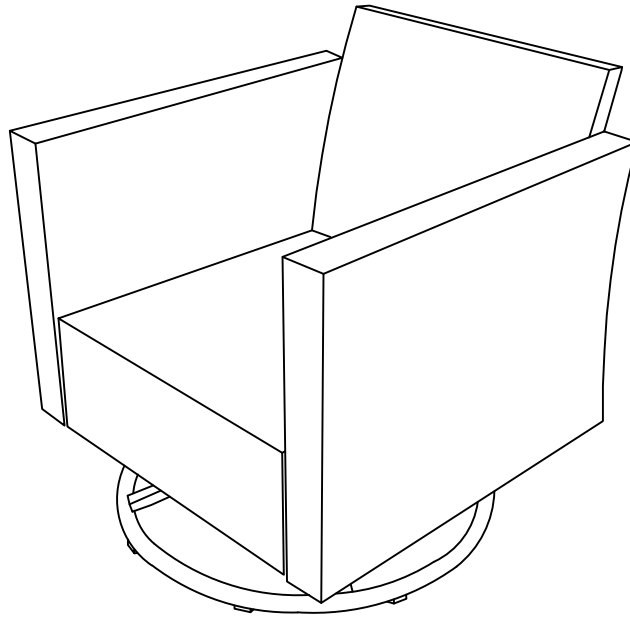

Advice:



1. Power tools are suggested to be used during installation.
2. More than one person may be required to assemble this product.
3. The best advice is not tightening up any screws until the whole piece is assembled. If having difficulty aligning holes, loosen the screws already installed and readjust the armrest.
4. To avoid mess-up or mismatch, please use the hardware of each box to install the furniture in the same box.

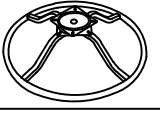

Single Swivel Chair

Parts List

Part Number	Picture	Description	QTY
SC-I		Chair Base #1	1
SC-J		Chair Base #2	1
L		Washer (M6)	16
M		Screw (M6*35)	4
N		Screw (M6*45)	4

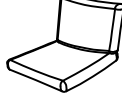
Part Number	Picture	Description	QTY
O		Nut (M6)	8
P		Allen Key	1
Q		Wrench (M6)	1
SC-R		Seat and Back Cushion	1

STEP 1

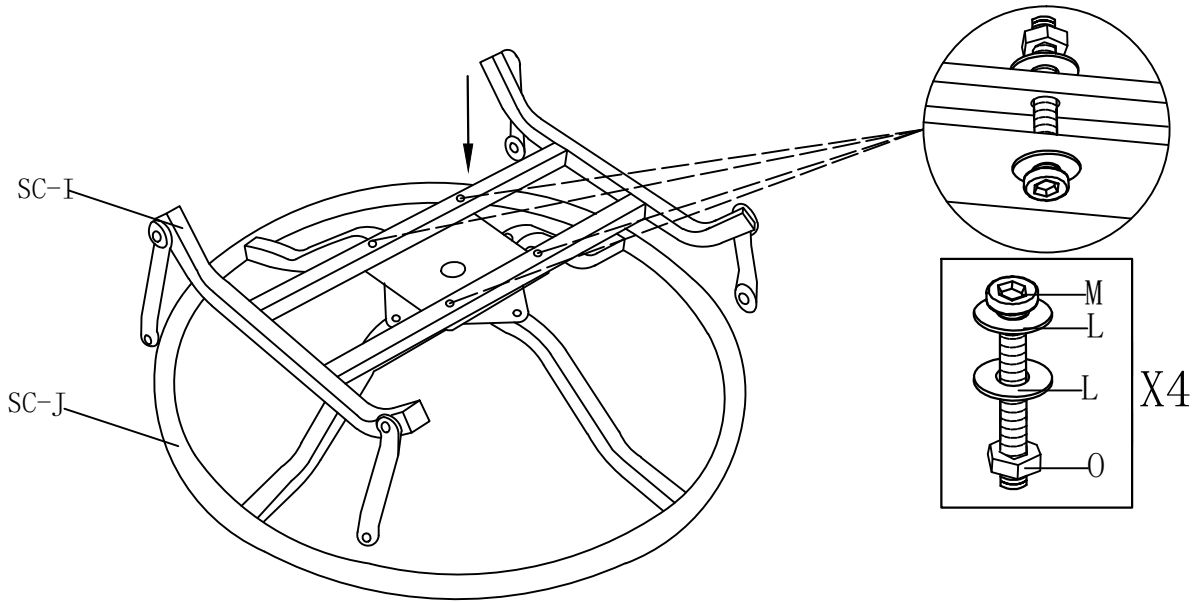

STEP 2

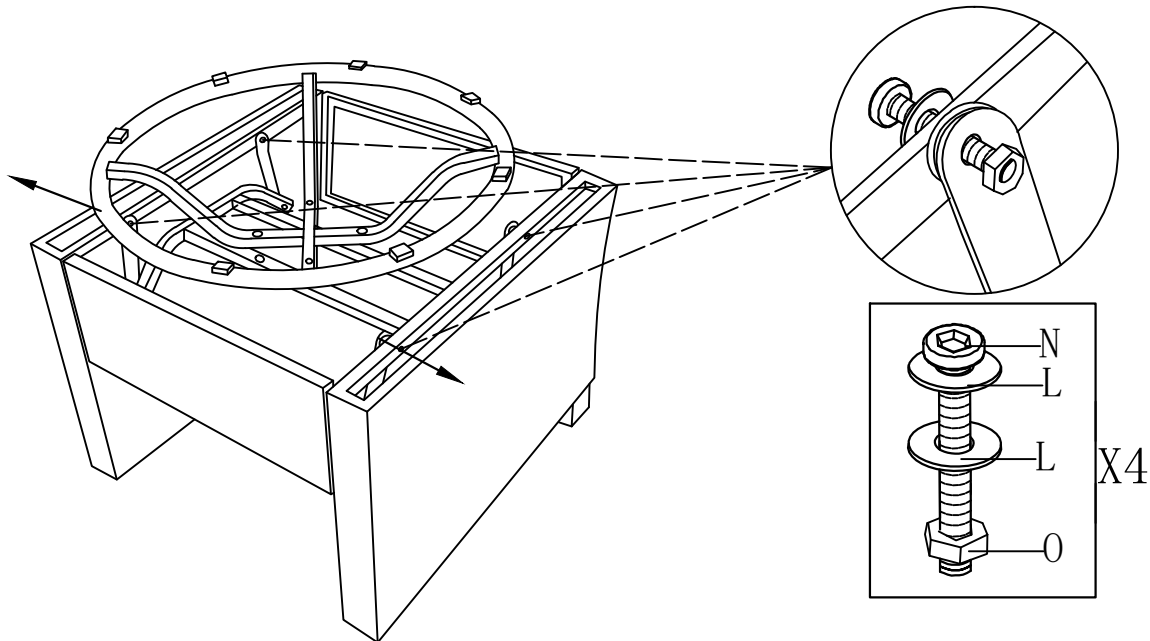

FINISH

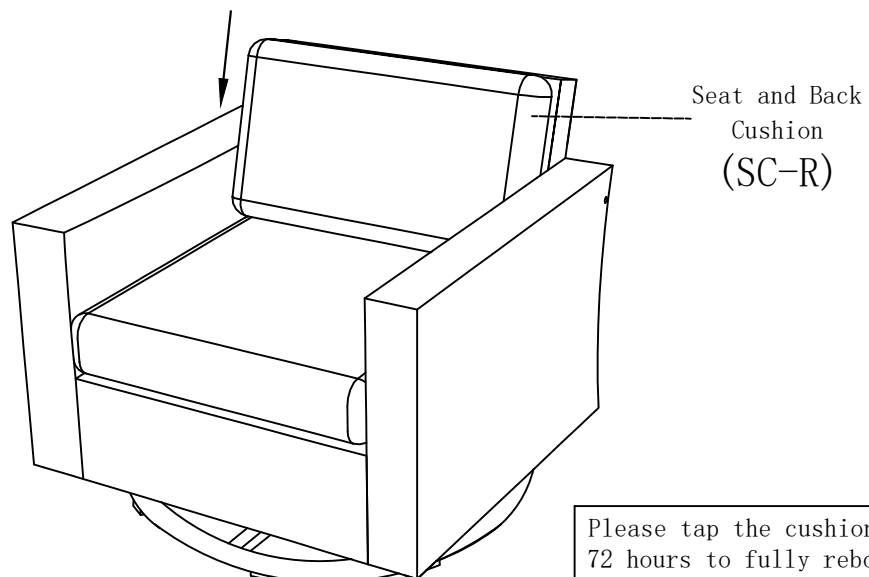

Please tap the cushions and wait 48 to 72 hours to fully rebound

Assembly Instruction



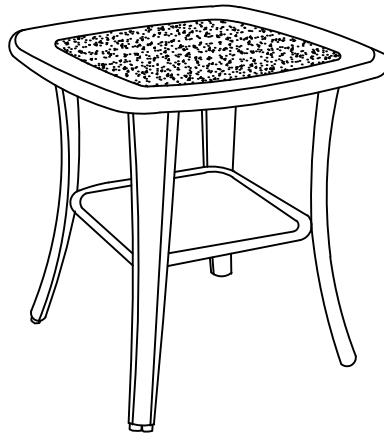

Advice:

1. Power tools are suggested to be used during installation.
2. More than one person may be required to assemble this product.
3. The best advice is not tightening up any screws until the whole piece is assembled. If having difficulty aligning holes, loosen the screws already installed and readjust the armrest.
4. To avoid mess-up or mismatch, please use the hardware of each box to install the furniture in the same box.

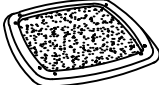

Side Table

Parts List

Part Number	Picture	Description	QTY
A		Wicker Layer	1
B		Desktop	1
C		Table Leg	4
D		Washer (M6)	12
E		Allen Key	1
Y		Screw (M6*16)	12

STEP 1

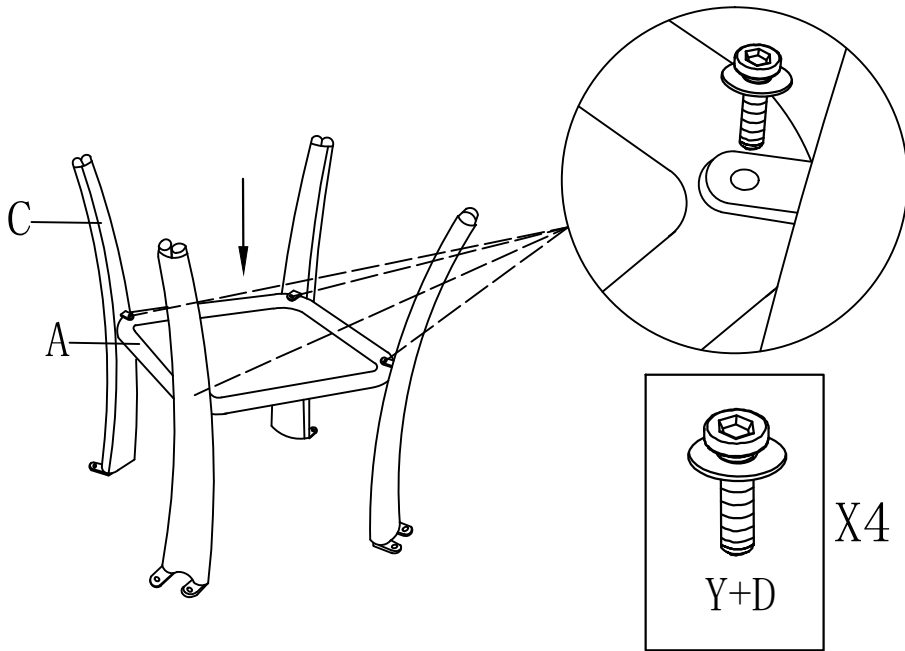

STEP 2

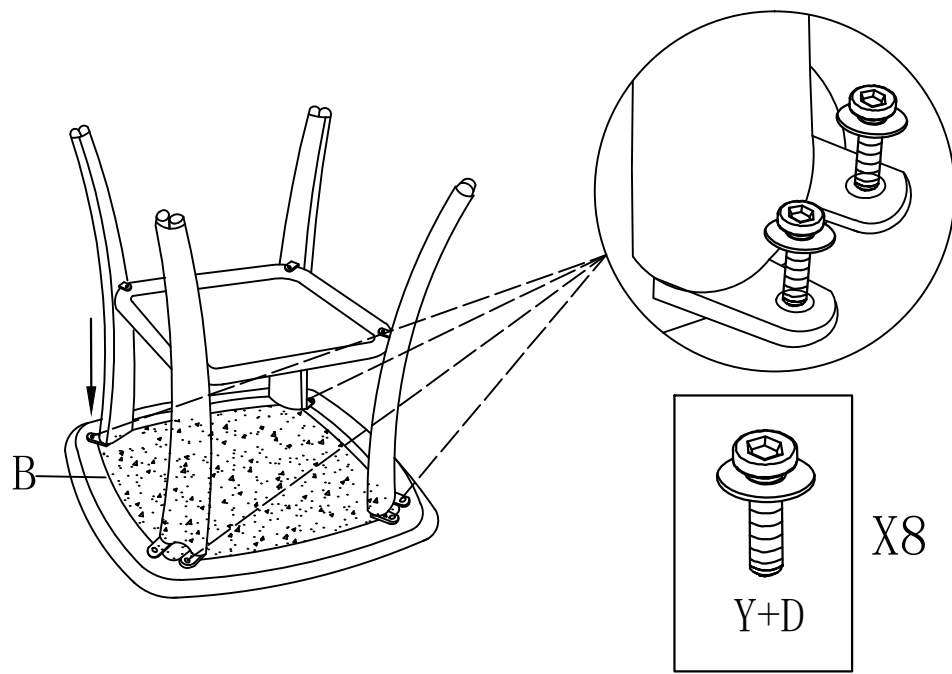

FINISH

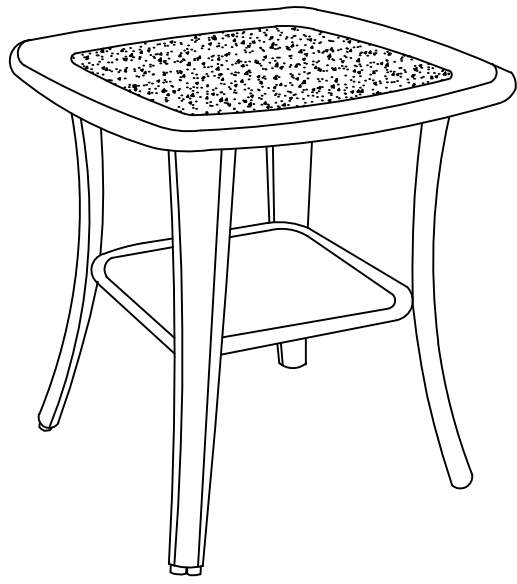

Assembly Instruction

Advice:

1. Power tools are suggested to be used during installation.
2. More than one person may be required to assemble this product.
3. The best advice is not tightening up any screws until the whole piece is assembled. If having difficulty aligning holes, loosen the screws already installed and readjust the armrest.
4. To avoid mess-up or mismatch, please use the hardware of each box to install the furniture in the same box.

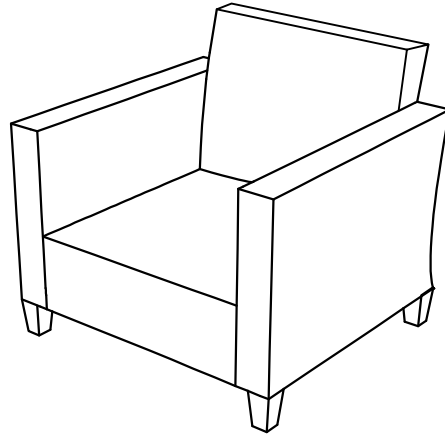

Single Chair

Parts List

Part Number	Picture	Description	QTY	Part Number	Picture	Description	QTY
C-A		Chair Back	1	I		Screw (M6*60)	2
C-B		Chair Seat	1	J		Screw (M6*95)	2
C-C		Left Arm	1	K		Washer (M6)	18
C-D		Right Arm	1	L		Nut (M6)	8
C-E		Seat and Back Cushion	1	M		Nut (M8)	4
F		Sofa Leg	4	N		Allen Key	1
G		Screw (M6*35)	4	O		Wrench (M8)	1
H		Screw (M6*65)	2	P		Wrench (M6)	1
				Q		Washer (M8)	4

STEP 1

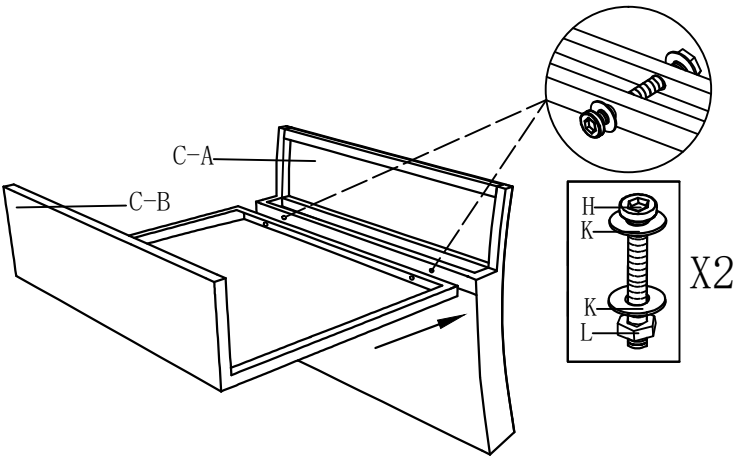

STEP 2

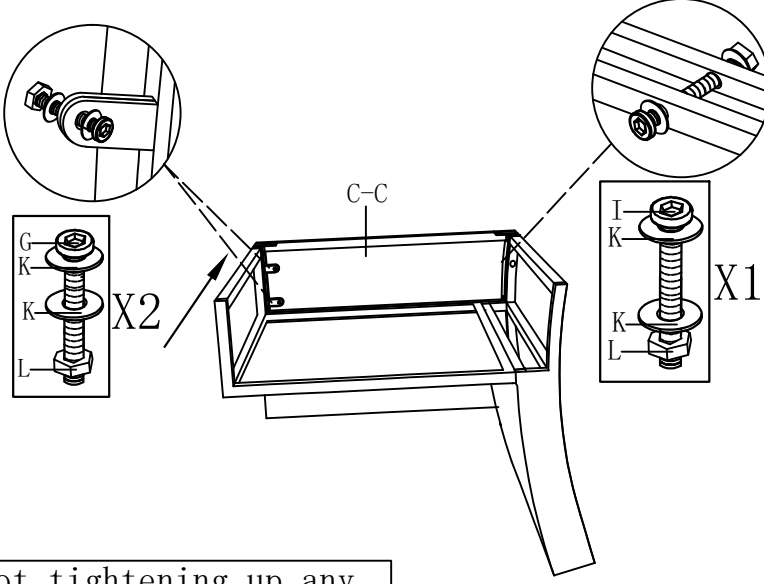

The best advice is not tightening up any screws until the whole piece is assembled.

STEP 3

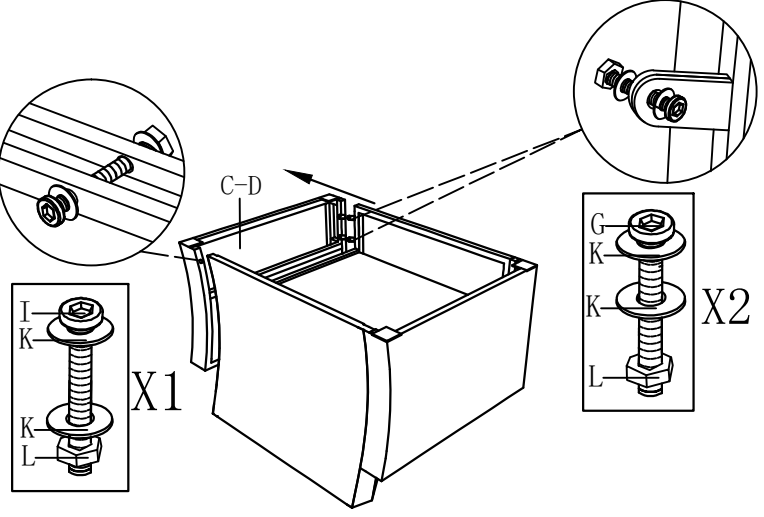

STEP 4

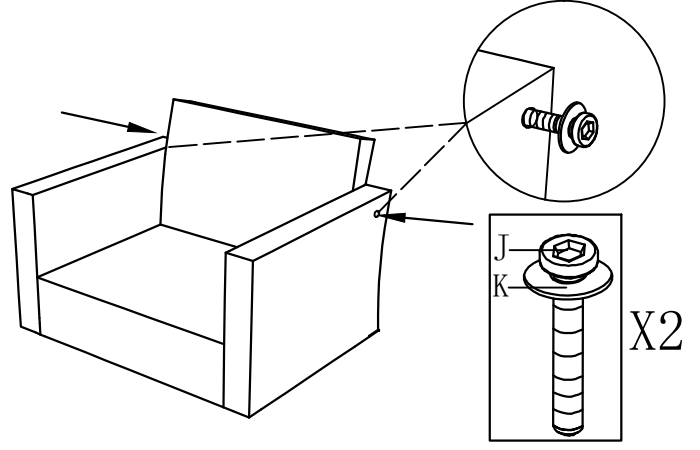

STEP 5

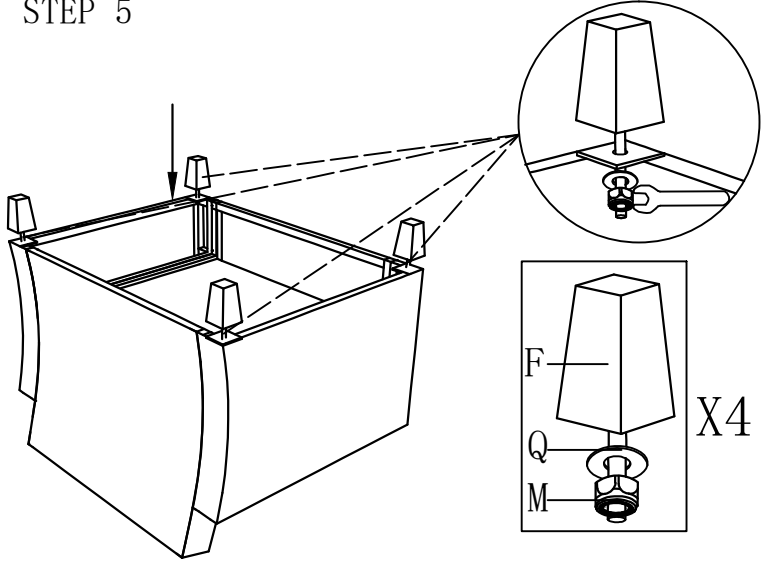

FINISH

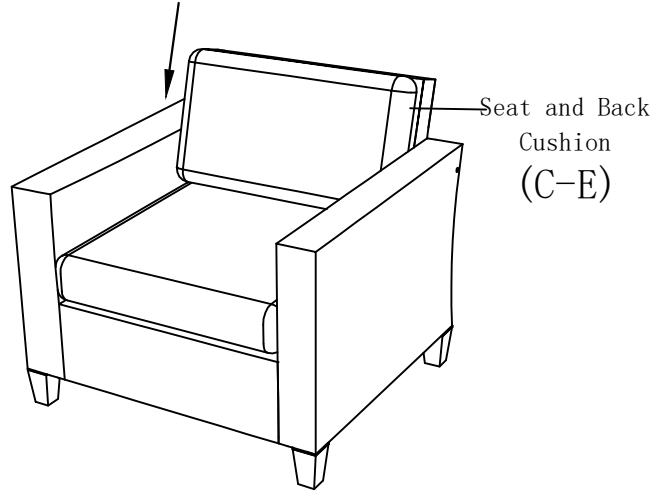

It is recommended to tighten the anti-slip screws with your own M8 wrench.

Please tap the cushions and wait 48 to 72 hours to fully rebound