

# Assembly Instructions



Please visit our website for the most current instructions, assembly tips, to report damage or request parts.

# General Assembly Guidelines

- I. Ensure that all parts and hardware are available before beginning assembly.
- II. Follow each step carefully to ensure the proper assembly of this product.
- III. Two people are recommended for ease in the assembly of this product.
- IV. The two main types of hardware used to assemble this product are: wood dowels and screws.
- V. A Phillips head screwdriver is required for the assembly of this product (not included)

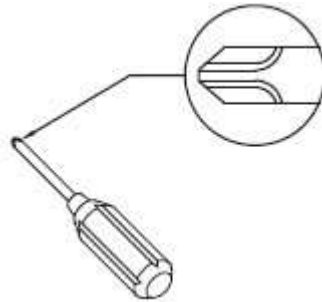





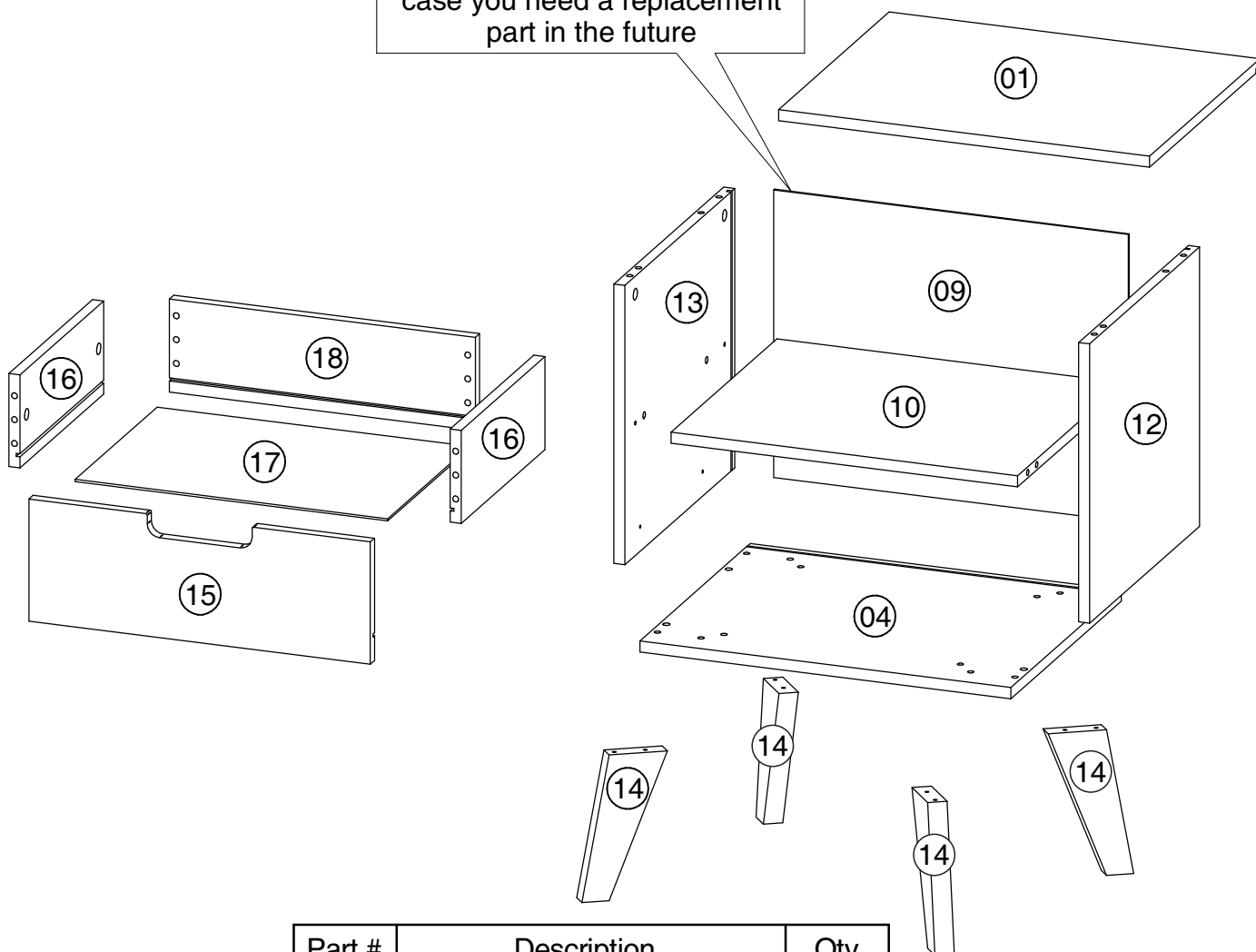

# Parts List

Keep the sticker for reference in case you need a replacement part in the future

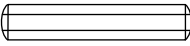
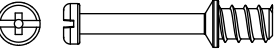

Part #	Description	Qty
01	Top Panel	1
04	Bottom Panel	1
09	Back Panel	1
10	Shelf	1
12	Right Side Panel	1
13	Left Side Panel	1
14	Foot	4
15	Drawer Front	1
16	Drawer Side	2
17	Drawer Bottom	1
18	Drawer Back	1

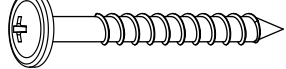
# Hardware List

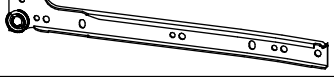
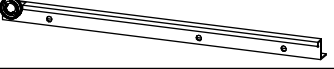
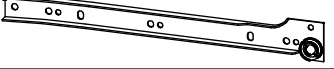
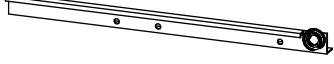
A		Ø8x30	Wooden Dowel	20 pcs
B		Ø7x30mm	Cam Bolt	12 pcs
C		Ø15x10mm	Cam Lock	12 pcs
D		Ø3,5x12mm	Screw	10 pcs
E		Ø3x16mm	Screw	4 pcs
F		Ø3,5x40mm	Screw	4 pcs
G		Ø5x40mm	Screw	8 pcs
H		14x14mm	Support	4 pcs
I		Ø 19mm	Sticker	8 pcs
K1		300mm	Metal Slider	1 pcs
K2		300mm	Metal Slider	1 pcs
L1		300mm	Metal Slider	1 pcs
L2		300mm	Metal Slider	1 pcs

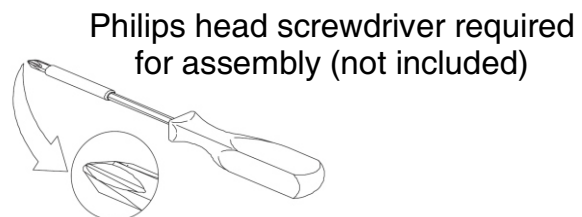
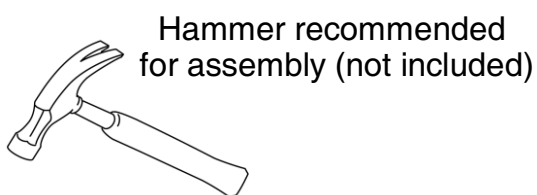

The hardware quantities listed above are required for proper assembly. Some extra hardware may also have been included.

# Step 1

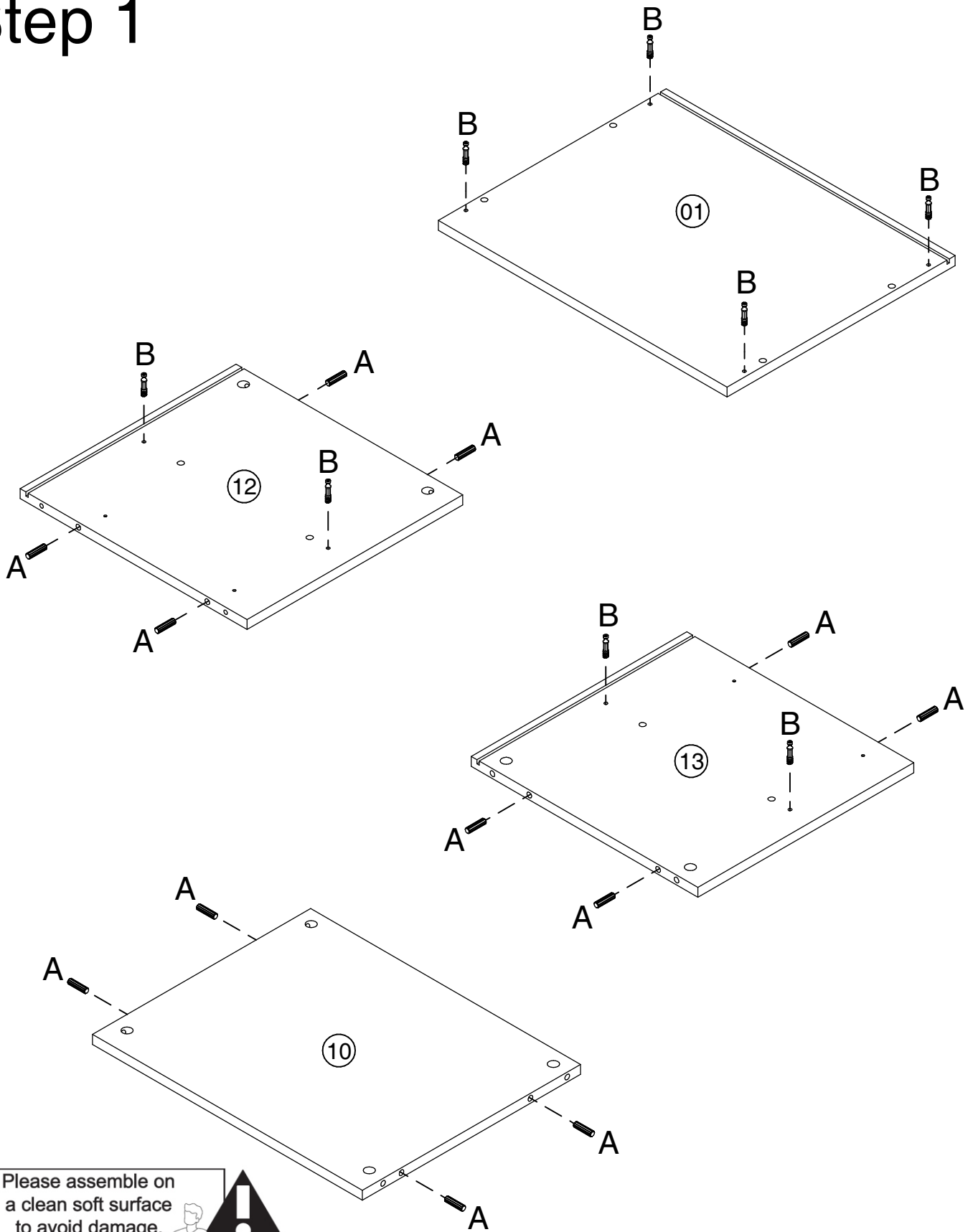

Please assemble on a clean soft surface to avoid damage.

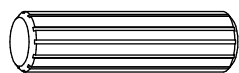
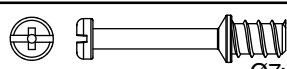

Insert wooden dowel (A) to parts (12,13,10) and insert cam bolt (B) to parts (1,12,13).

A	 Ø8x30	12
B	 Ø7x30mm	8

# Step 2

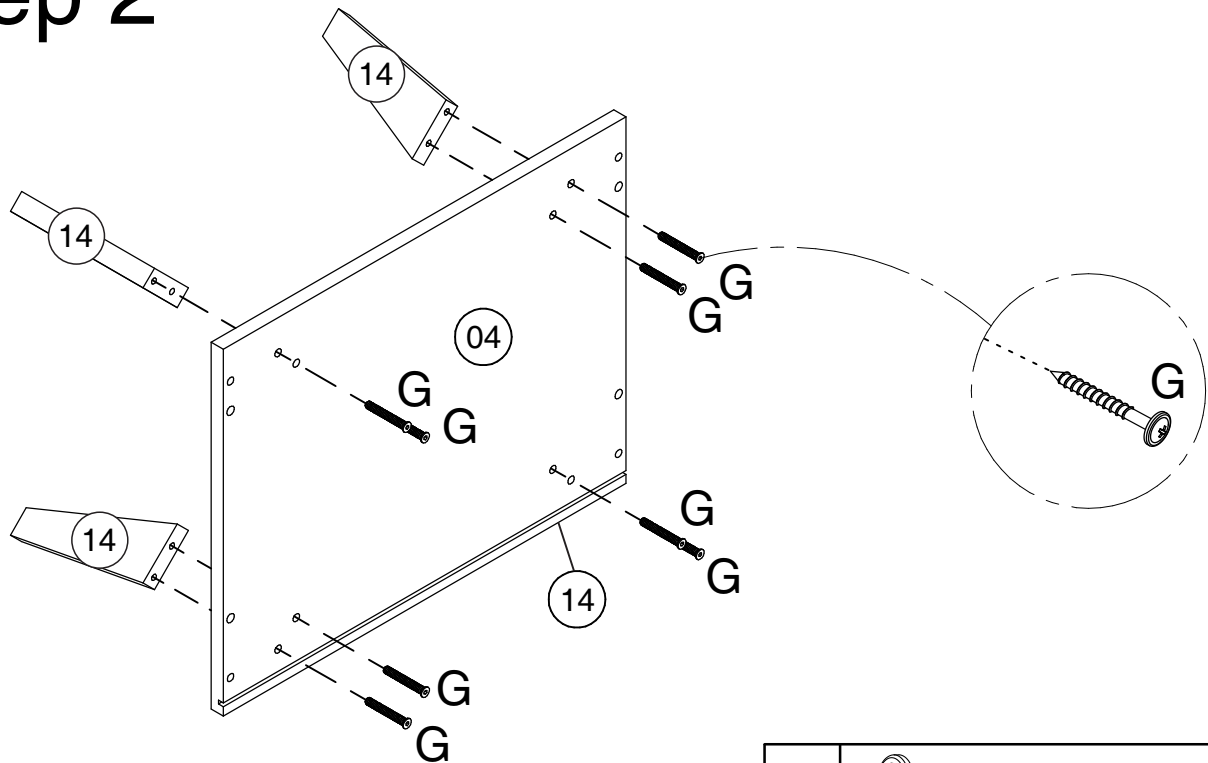

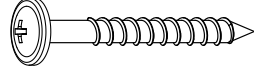
G		Ø5x40	8
---	---	-------	---

Attach feet (14) to part (4) with screw (G).

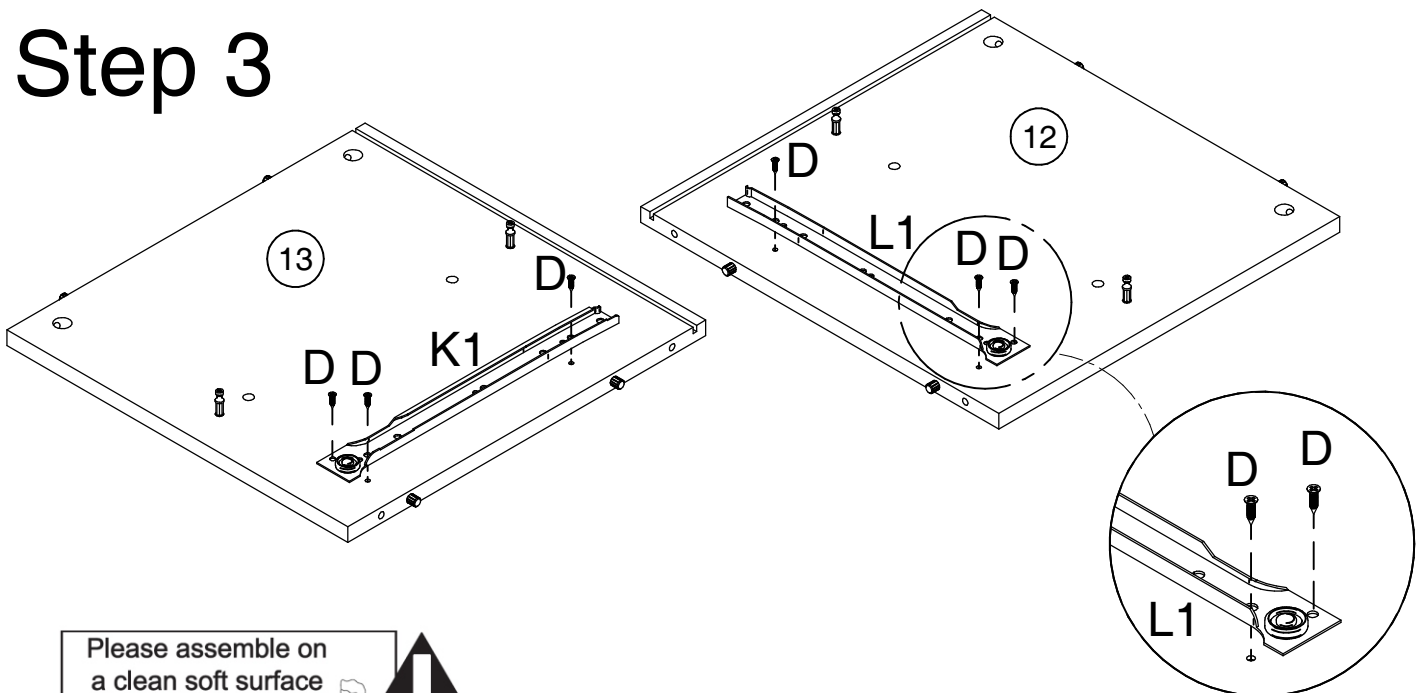

# Step 3



Please assemble on a clean soft surface to avoid damage.

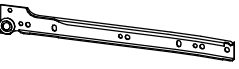
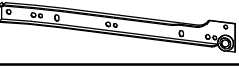

Attach Metal Slider (K1,L1) to parts (12,13) with screw (D).

K1		300mm	1
L1		300mm	1
D		Ø3,5x12mm	6

# Step 4

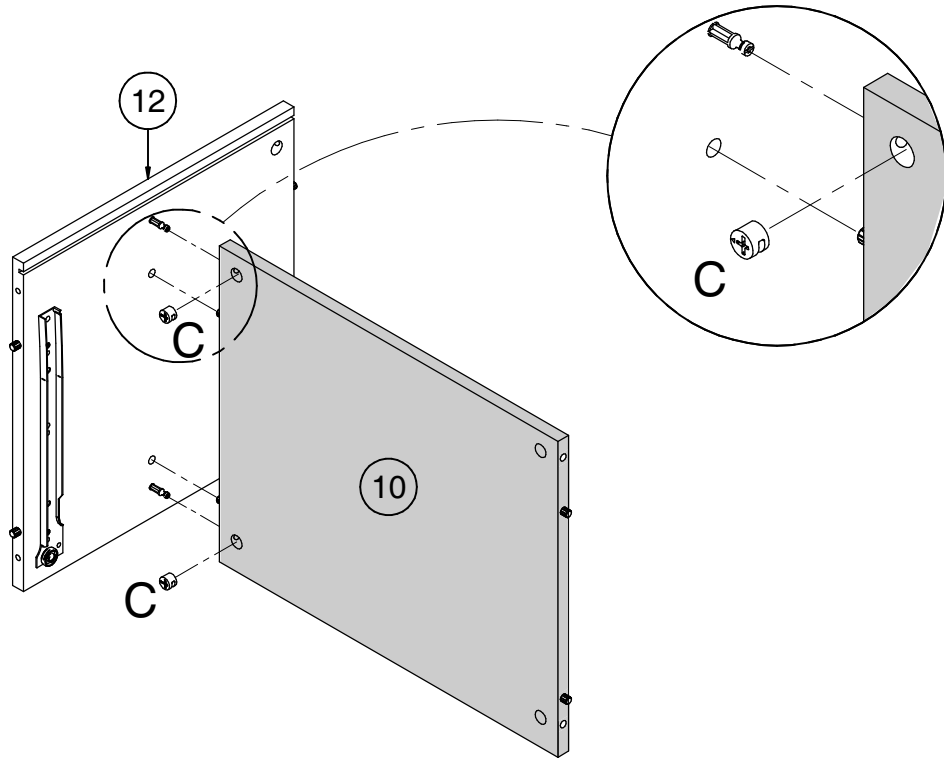
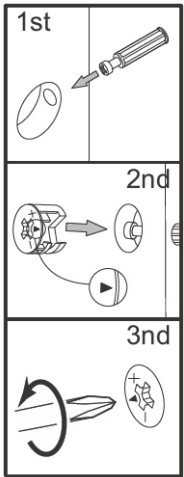

Secure part (10) to part (12) using cam lock (C) as per diagram.

C			Ø15x10mm	2
---	--	--	----------	---

# Step 5

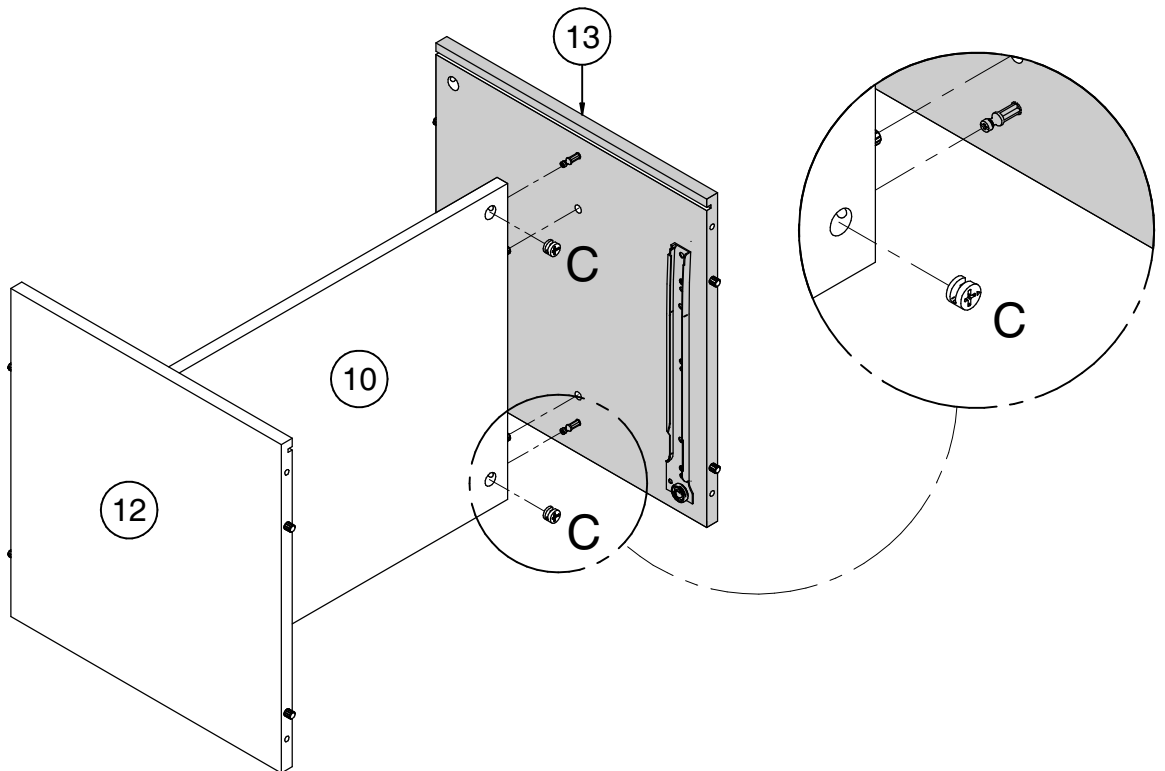
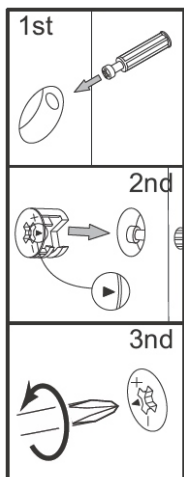

Secure parts (12,10) to part (13) using cam lock (C) as per diagram.

C			Ø15x10mm	2
---	--	--	----------	---

# Step 6

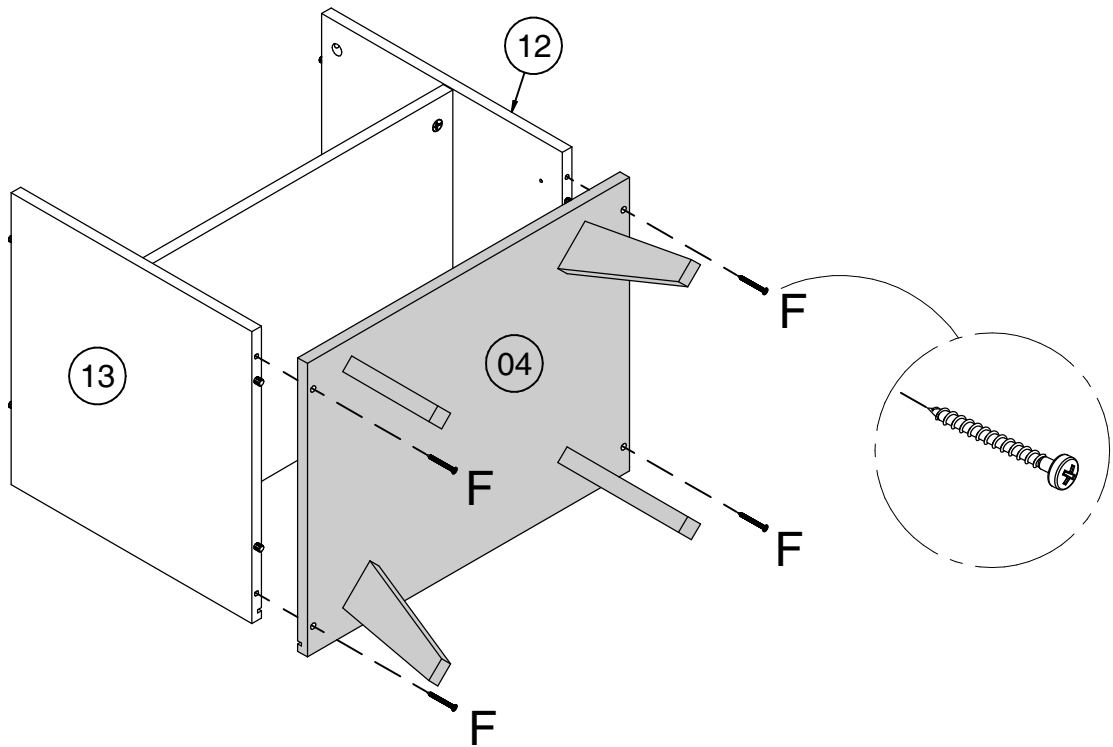

Secure part (4) to parts (12,13) using screw (F)

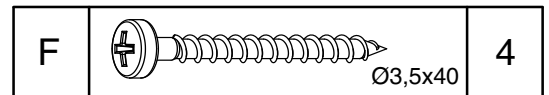

# Step 7

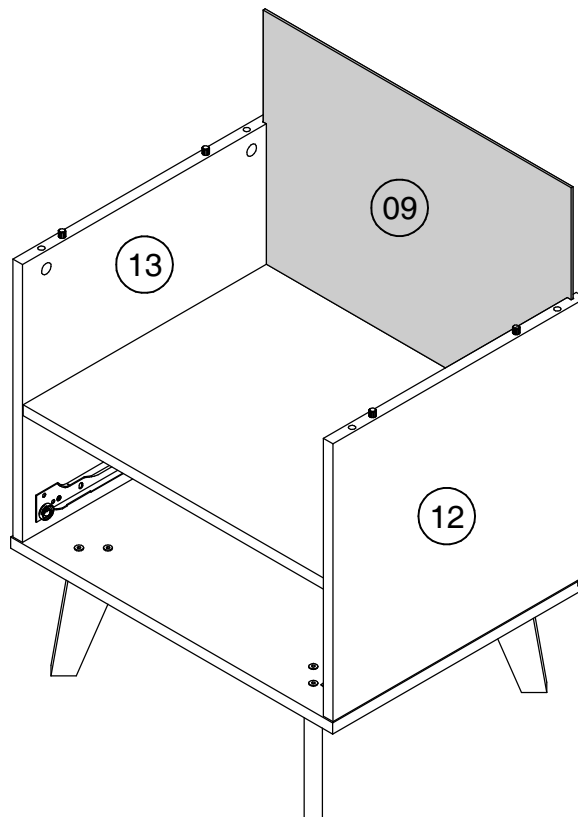

Slide back panel (9) into side panel (12,13).

# Step 8

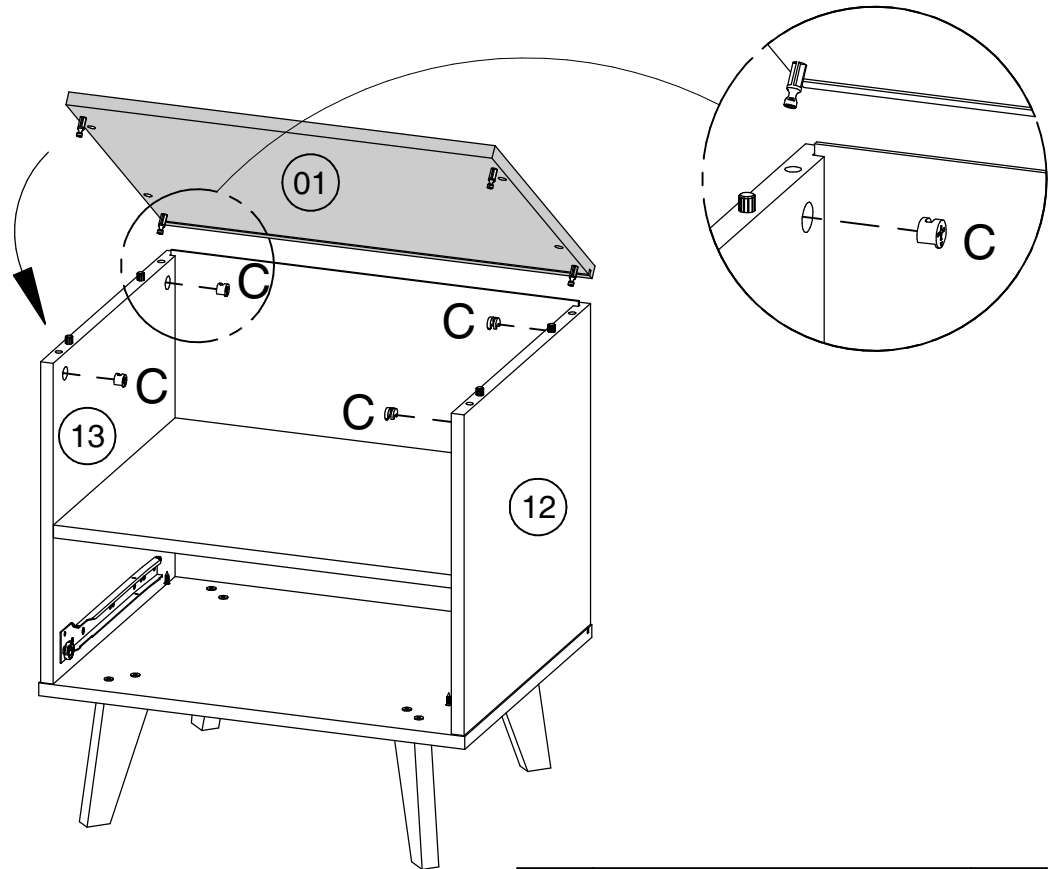
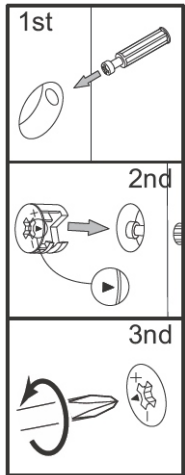



Secure part (1) to parts (12,13) using cam lock (C).

C		Ø15x10mm	4
---	--	----------	---

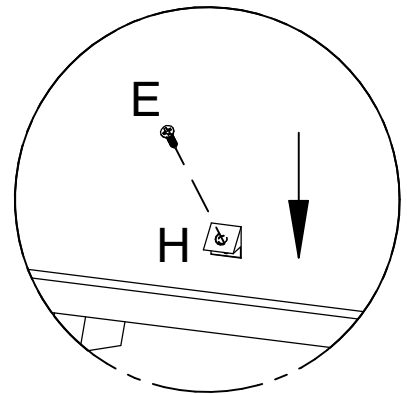
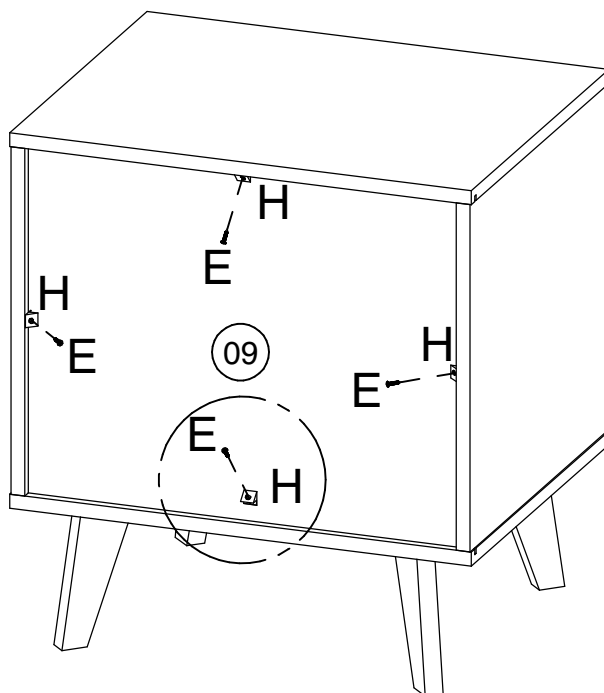
# Step 9



Secure back panel (9) using screw (E) and support (H).

E		Ø3x16mm	4
H		14x14mm	4

# Step 10

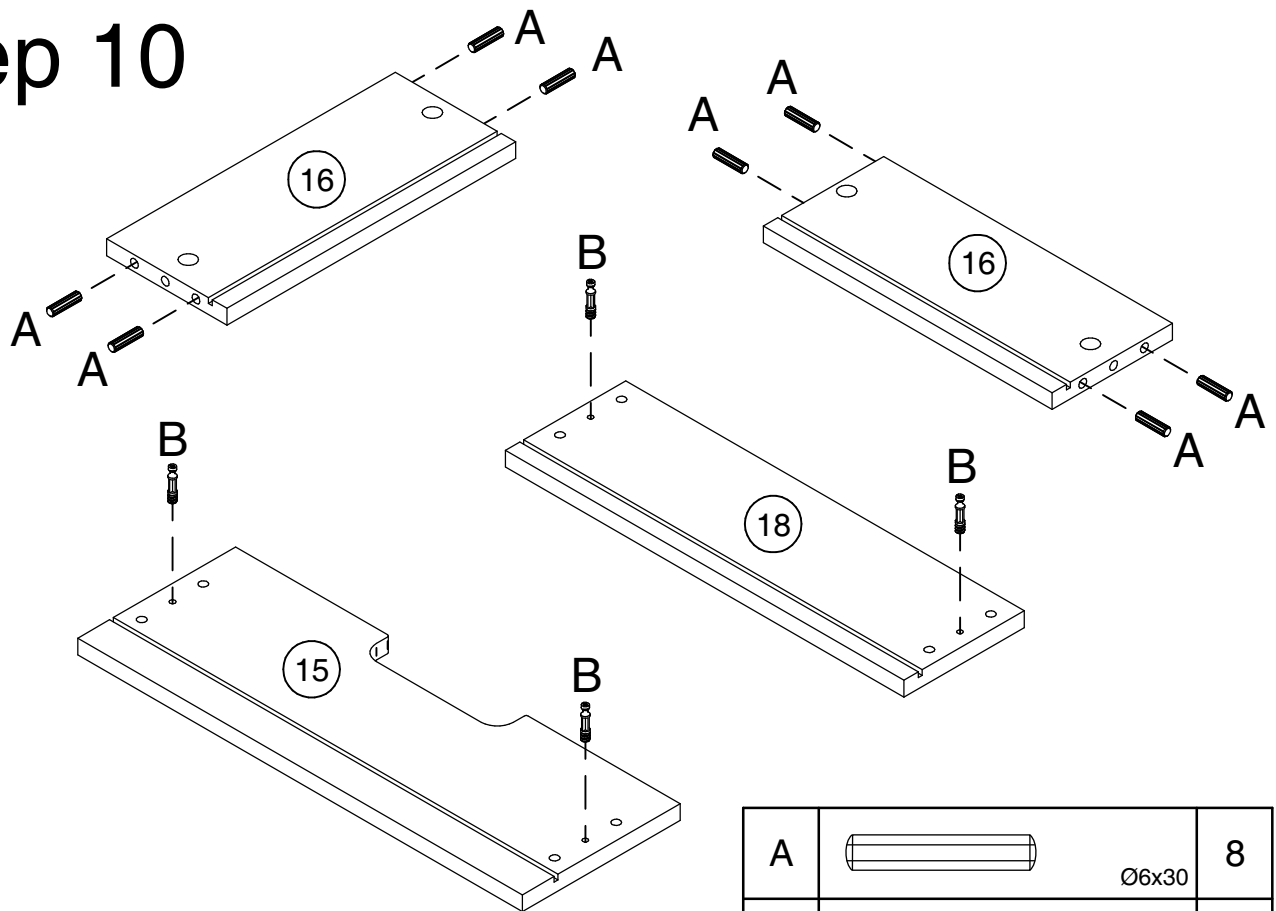

Insert wooden dowel (A) to parts (16,16) and insert cam bolt (B) to part (15,18).

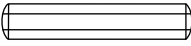
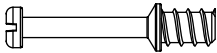
A		Ø6x30	8
B		Ø7x30mm	4

# Step 11

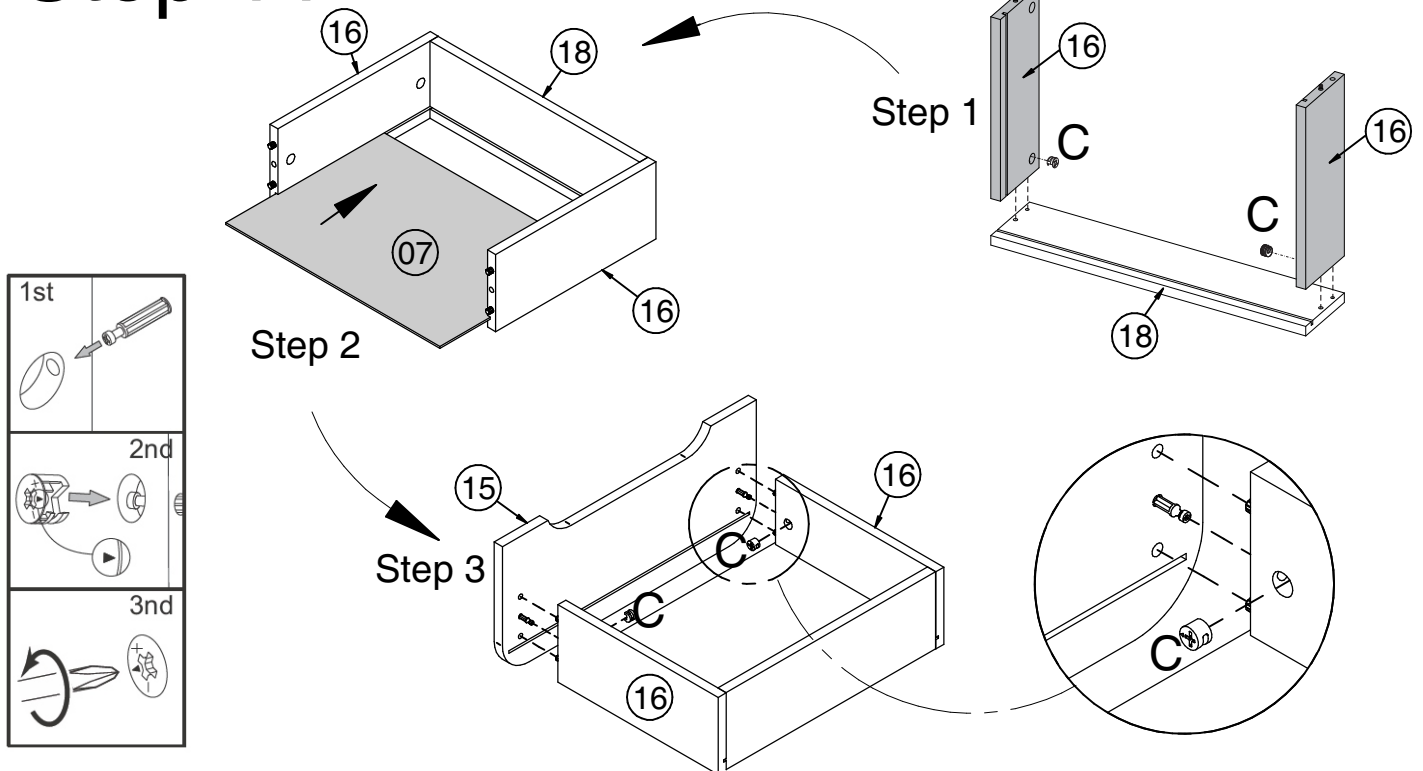



First: Secure parts (16,16) to part (18) using cam lock (C).  
 Second: Slide part (07) into grooves as per diagram.  
 Third: Secure part (15) to parts (16,16) using cam lock (C).

C		Ø15x10mm	4
---	---	----------	---

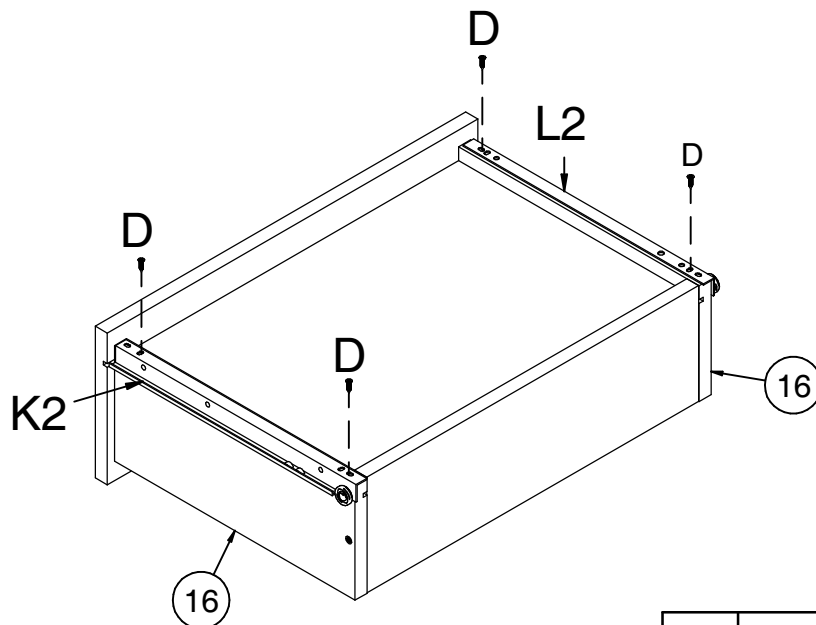
# Step 12



Attach Metal Slider (K2,L2) to parts (16,16) with screw (D).

D	 Ø3,5x12mm	4
K2	 300mm	1
L2	 300mm	1

# Step 13

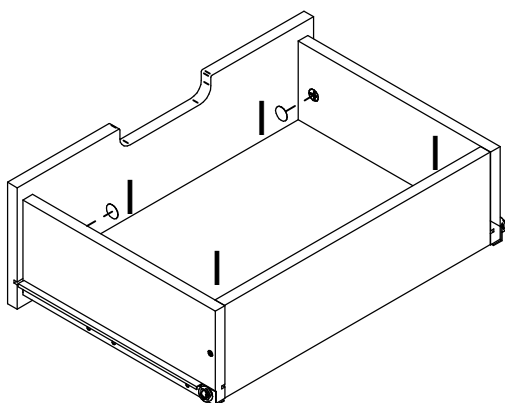

Place sticker (I) over holes as per diagram.

I	 Ø 19mm	8
---	--	---

# Step 14

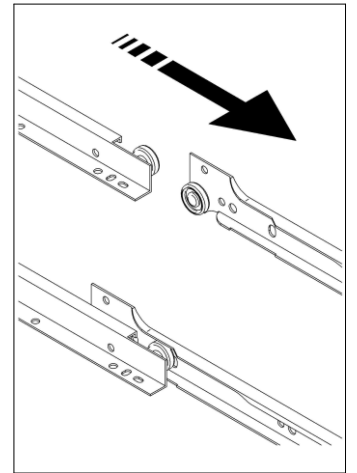
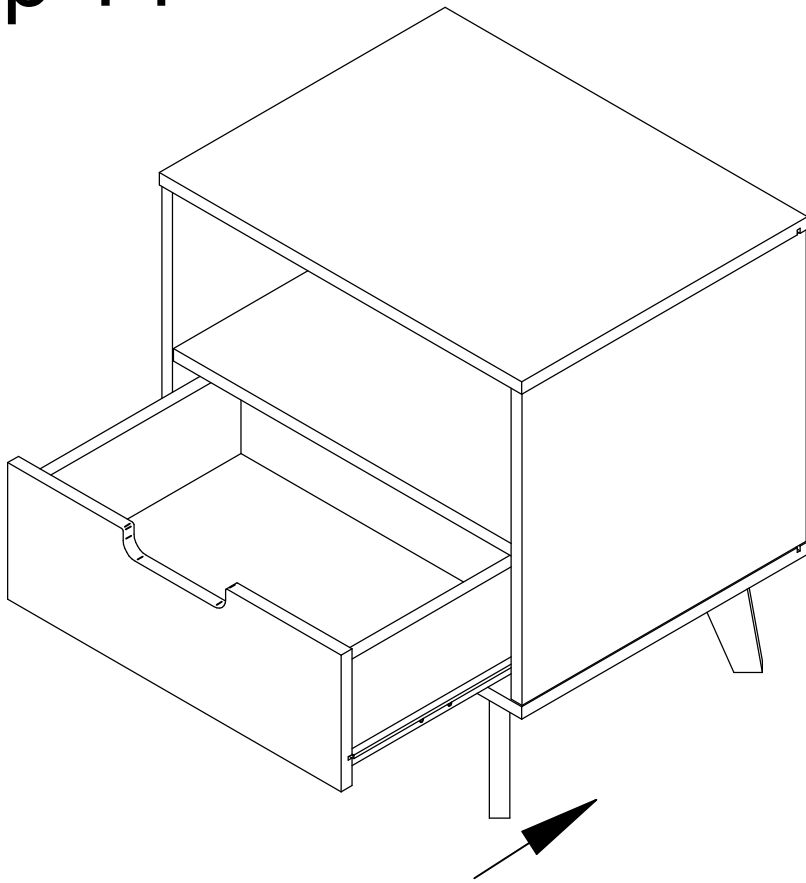

# Step 15

