

READ AND SAVE THIS INSTRUCTION FOR FUTURE USE

ASSEMBLY INSTRUCTION

EXPLOSION MAP AND INSTALLATION INSTRUCTION FOR COMPLEX HARDWARE

EXPLOSION MAP

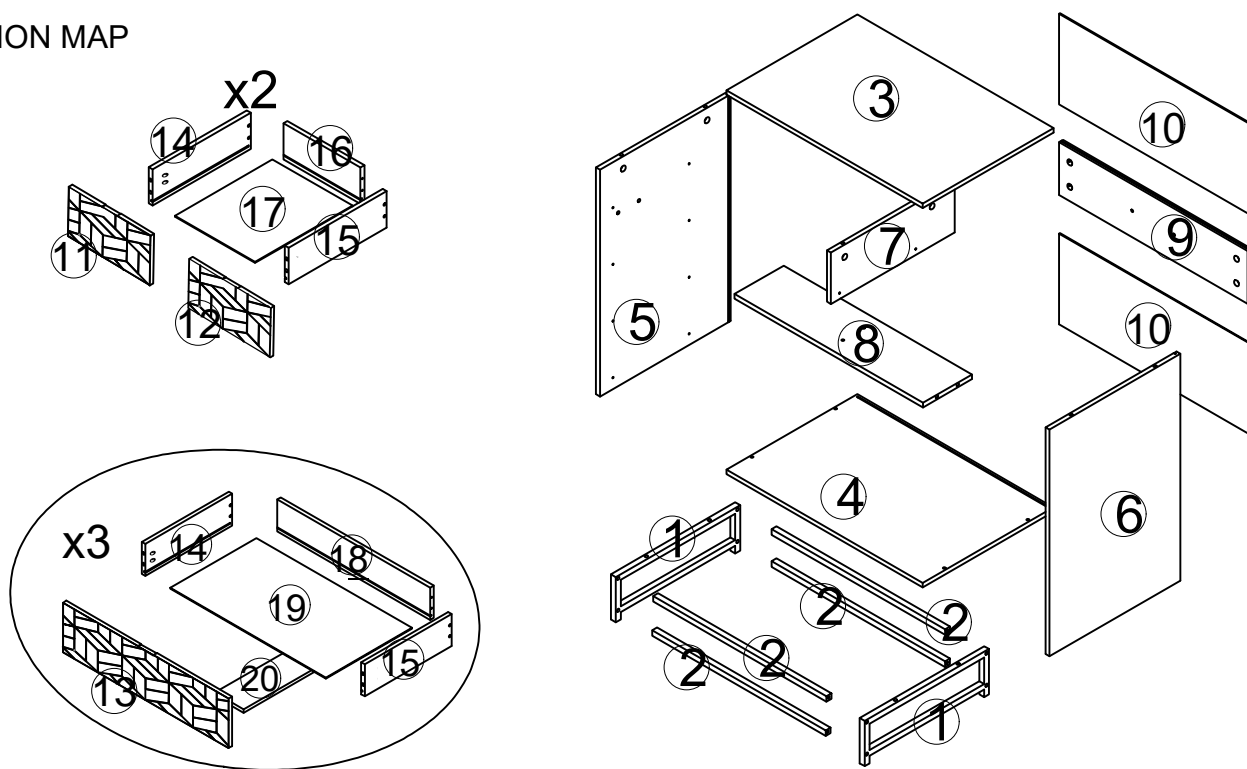

Three-in-one installation method

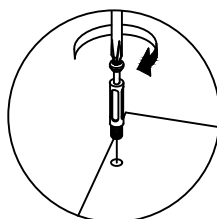
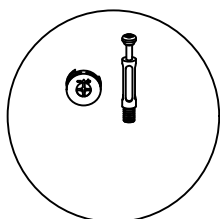

Insert corresponding plate

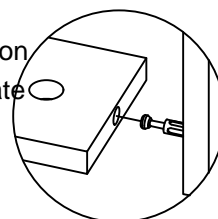



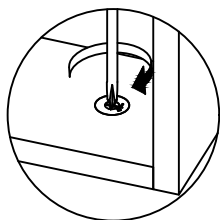



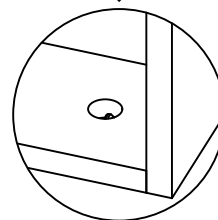
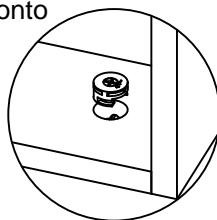

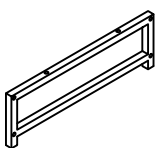
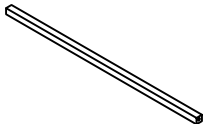
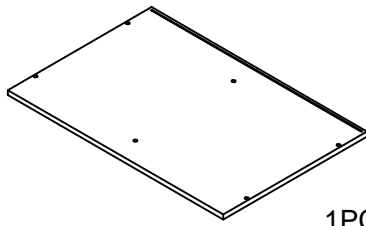
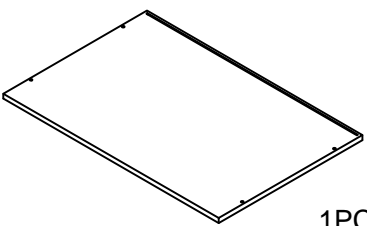
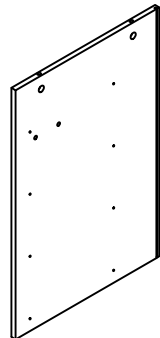

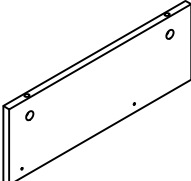
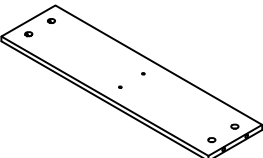
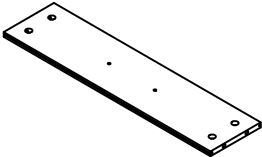
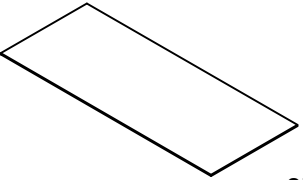
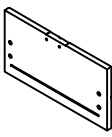
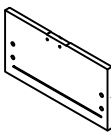
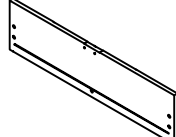
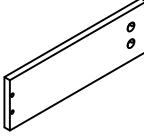
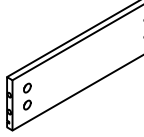
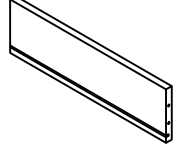
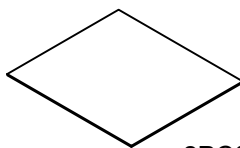
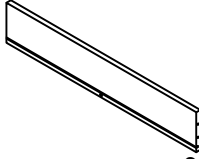
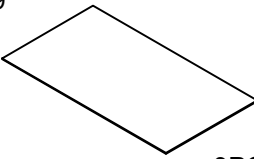
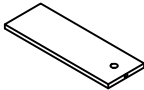
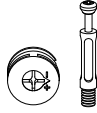

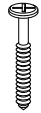
Rotate 180° by clockwise direction



Pay attention to the gap direction



<p>1</p>  <p>2PCS</p>	<p>2</p>  <p>4PCS</p>	<p>3</p>  <p>1PCS</p>	<p>4</p>  <p>1PCS</p>					
<p>5</p>  <p>1PCS</p>	<p>6</p>  <p>1PCS</p>	<p>7</p>  <p>1PCS</p>	<p>8</p>  <p>1PCS</p>					
		<p>9</p>  <p>1PCS</p>	<p>10</p>  <p>2PCS</p>					
<p>11</p>  <p>1PCS</p>	<p>12</p>  <p>1PCS</p>	<p>13</p>  <p>3PCS</p>	<p>14</p>  <p>5PCS</p>	<p>15</p>  <p>5PCS</p>	<p>16</p>  <p>2PCS</p>			
<p>17</p>  <p>2PCS</p>	<p>18</p>  <p>3PCS</p>	<p>19</p>  <p>3PCS</p>	<p>20</p>  <p>3PCS</p>					
<p>A</p>  <p>34PCS</p>	<p>B</p>  <p>M5X50 6PCS</p>	<p>C</p>  <p>M4X14 50PCS</p>	<p>D</p>  <p>M4X40 25PCS</p>	<p>E</p>  <p>M6X35 8PCS</p>	<p>F</p>  <p>M6X30 4PCS</p>	<p>G</p>  <p>3PCS</p>	<p>J</p>  <p>4PCS</p>	<p>M</p>  <p>5PCS</p>
<p>K</p>  <p>5PCS</p>								

- A x8
- M x2
- C x4
- D x8

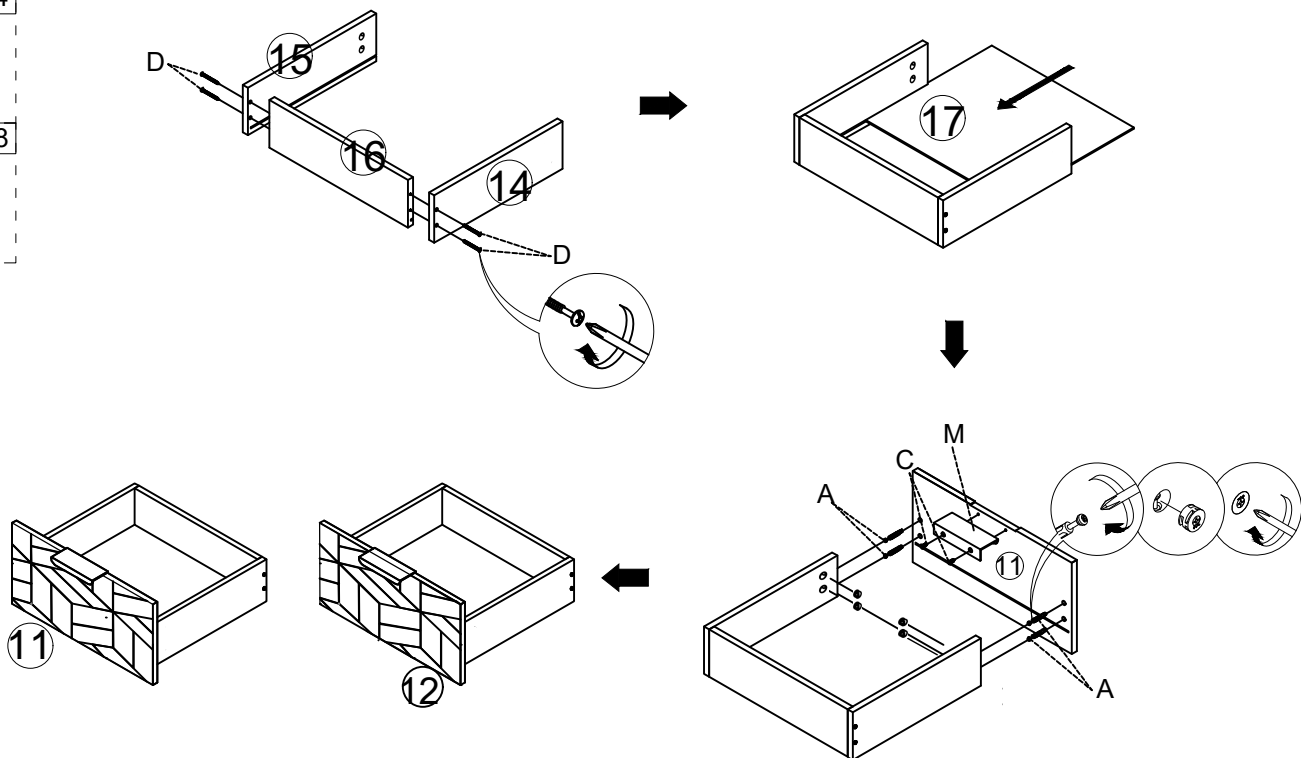

- A x12
- M x3
- G x3
- C x6
- D x15

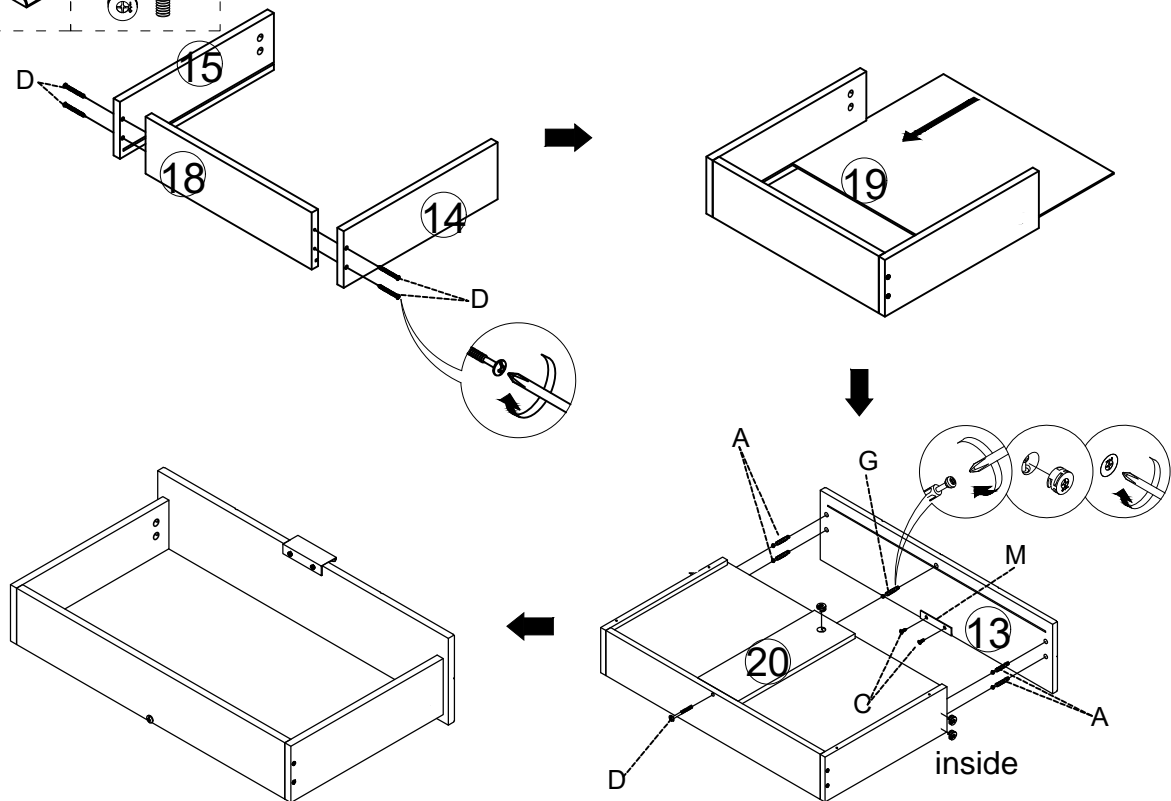

K x5



C x40



As shown in the figure, install the slide rail into positioning hole of part 5 ,6and 7 with screws C

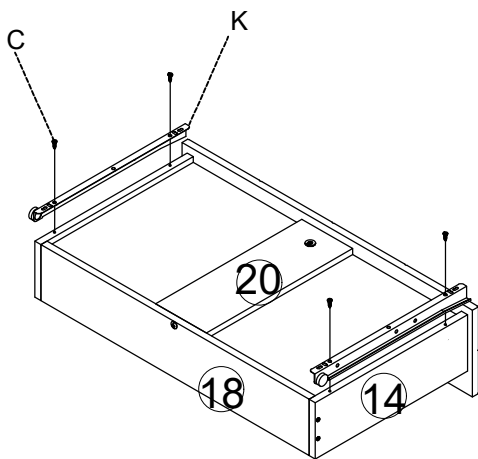
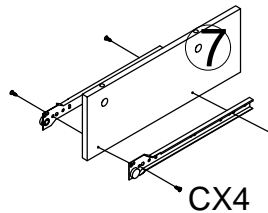
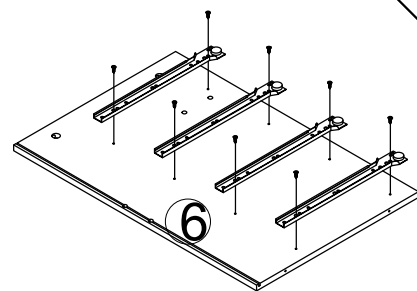
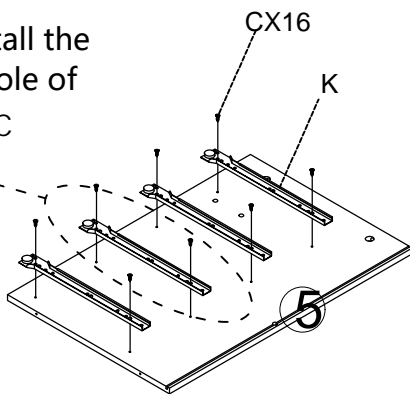
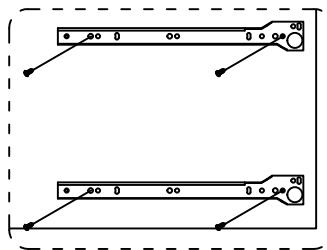

x3

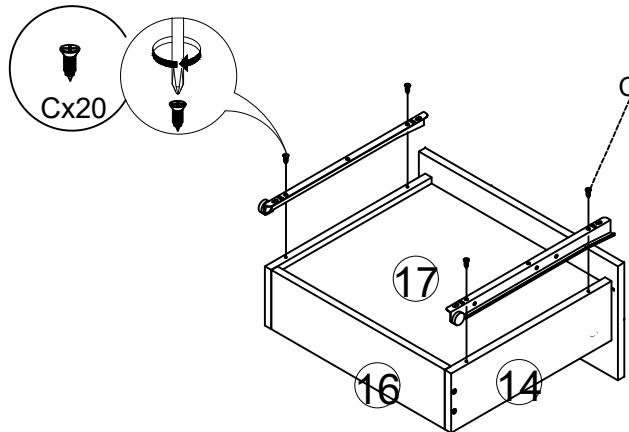

x2

B x2

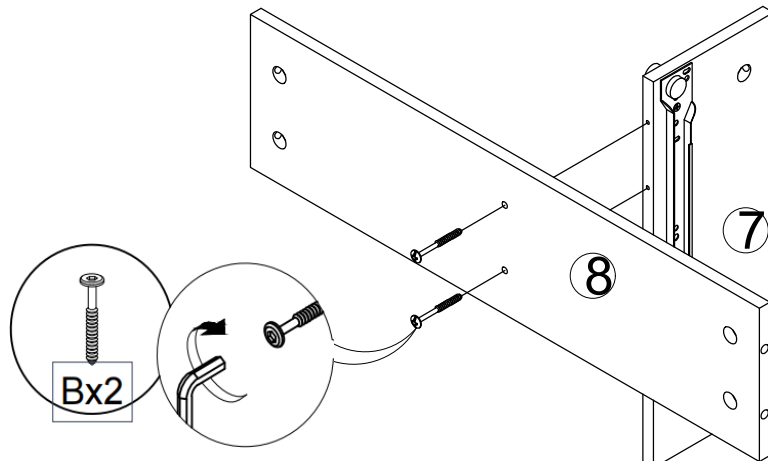

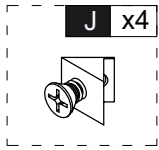
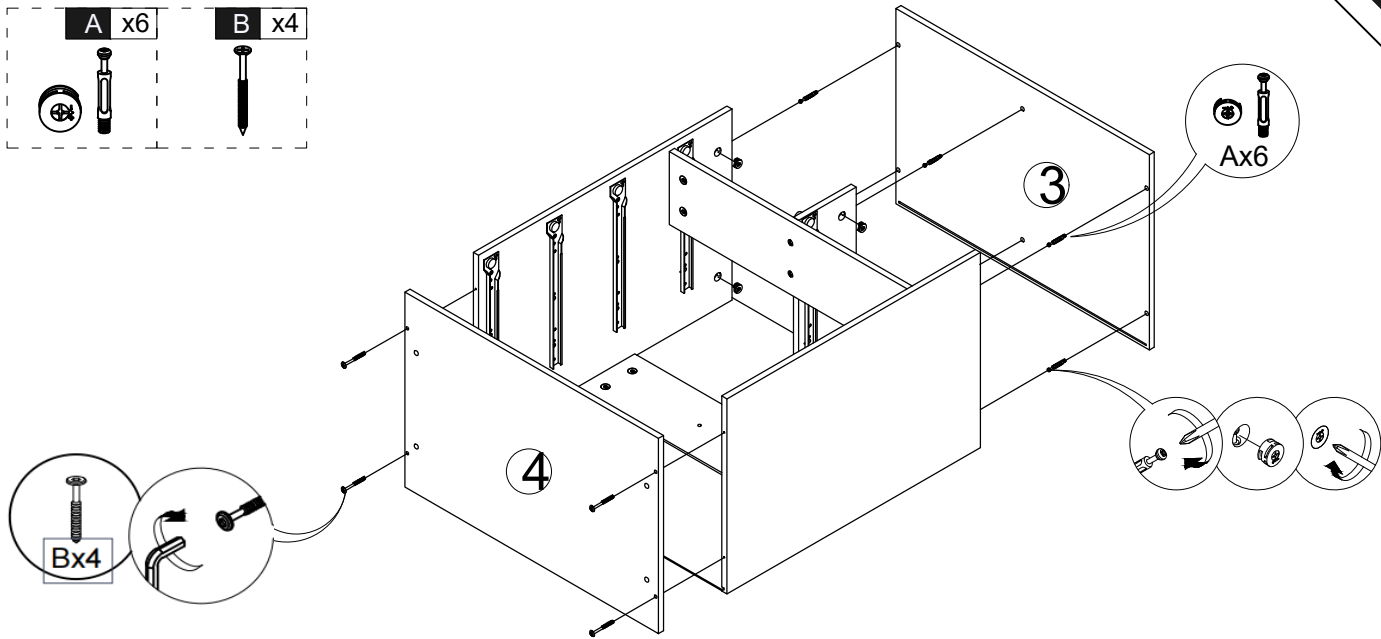
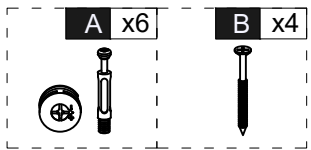
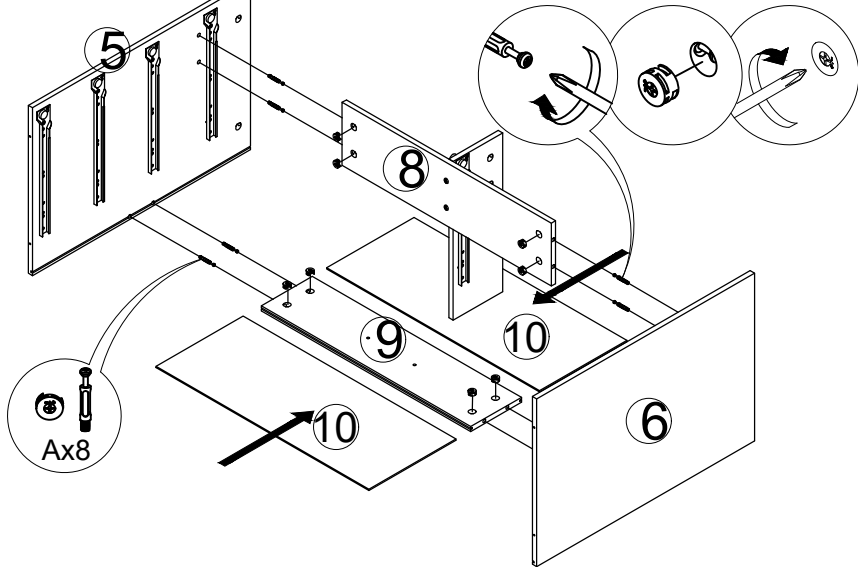
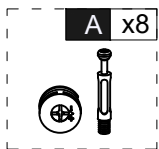

As shown in the figure, the four corners of the back plate need to be fixed with screws J

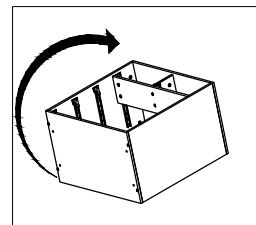
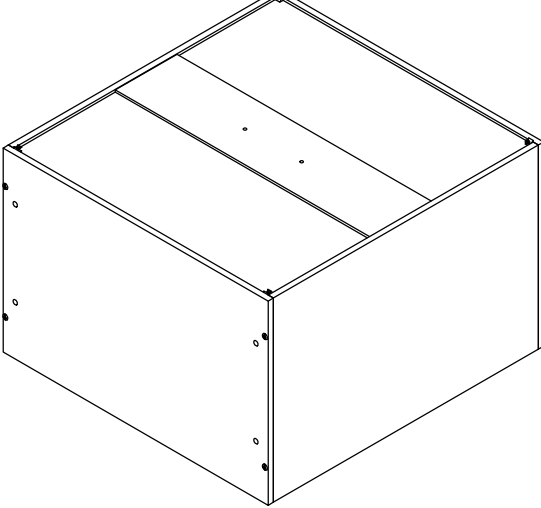
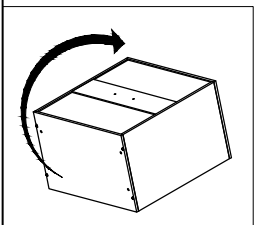

E x8

F x4

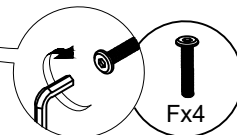
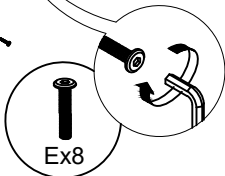
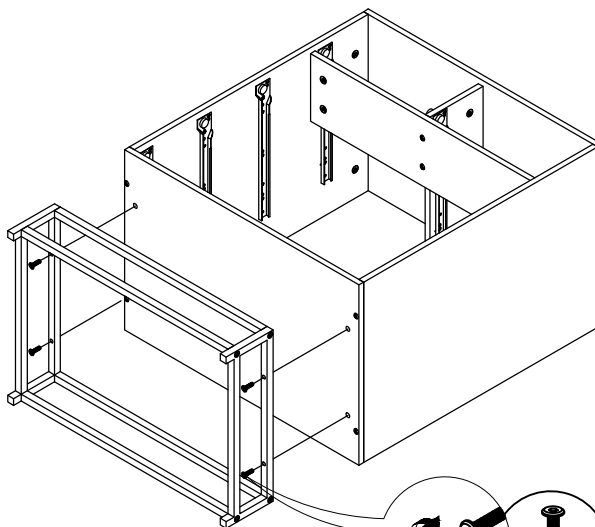
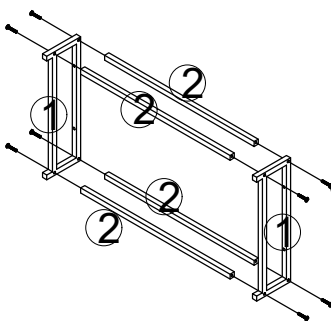

D x2

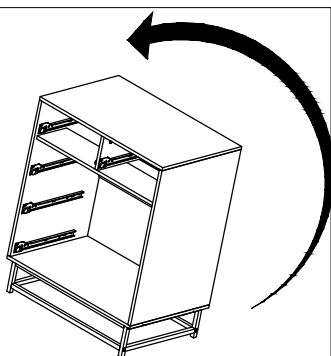
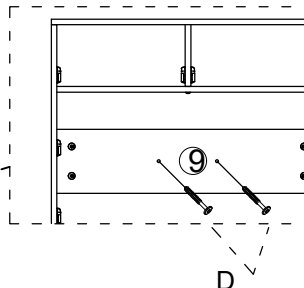
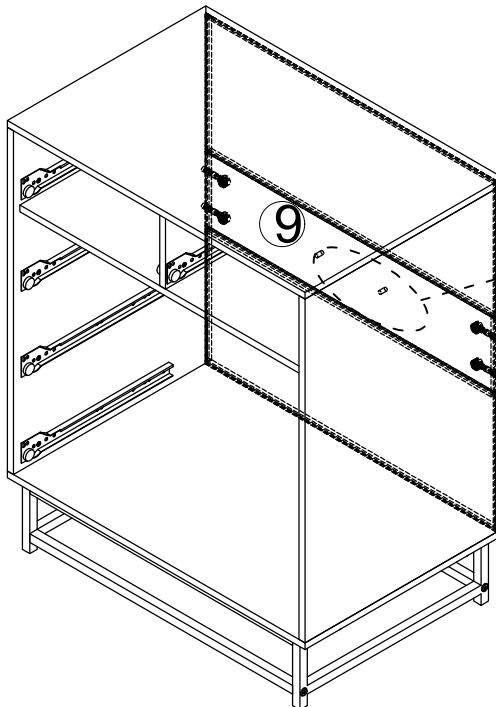

As shown in the figure, the screw D is passed through the holes of Part 9 to fix the cabinet on the wall.

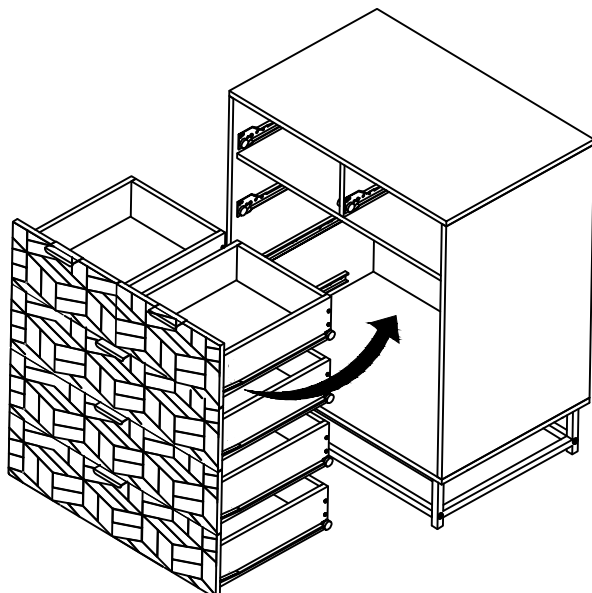

End

CONTACTUS

***Dear customer, thank you for purchasing our products!
We are proud to present our customers with high quality products!***



***If you have any product quality or use problems, please
contact our customer service by email, we will ensure
your satisfaction.***