

ASSEMBLY INSTRUCTIONS (CONTINUED)

STEP 3

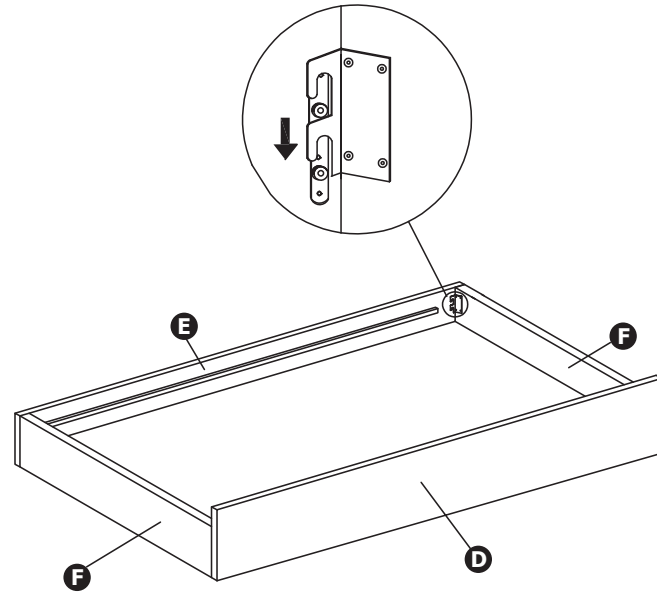

Attach Trundle Front Panel (Part D) and Trundle Back Panel (Part E) to Trundle Side Panel (Part F) as shown.

STEP 4

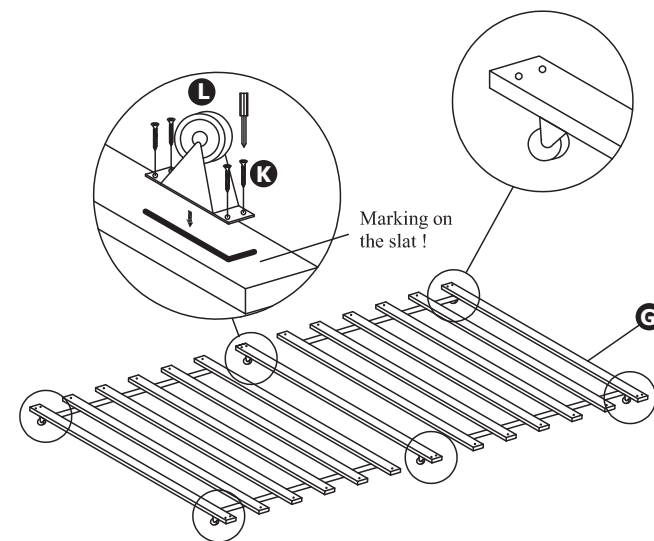

Align the Rollers (Part L) to the Trundle Slats (Part G) as shown. Be sure to align the rollers with the marking on the slats. Secure the roller using four 16mm Screws (Part K) for each roller.

STEP 5

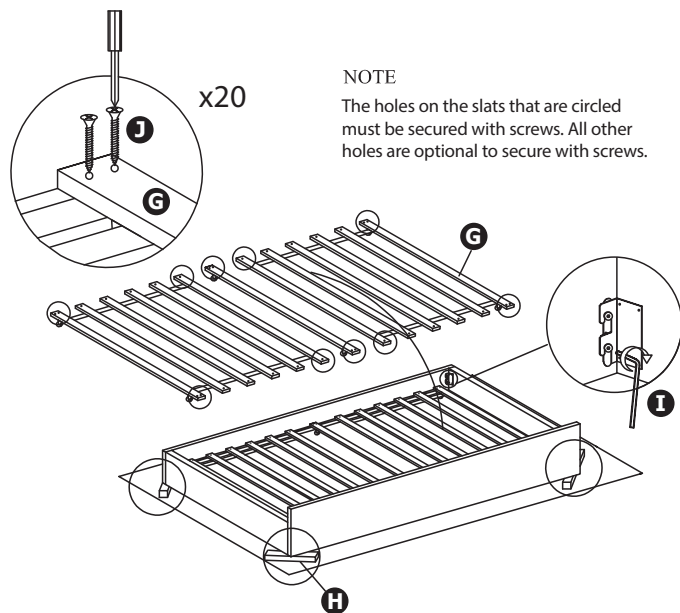

NOTE
The holes on the slats that are circled must be secured with screws. All other holes are optional to secure with screws.

Place the Wooden Blocks (Part H) under the trundle side panels to make attaching the slats easier. Place the Trundle Slats (Part G) on the runner boards of the trundle front and back panels. Tighten the front and back panels to the side panels using Hex Key (Part I). Tighten the slats using 20 of the 32mm screws (Part J) in the holes that are circled. Remove the wooden blocks.

STEP 6

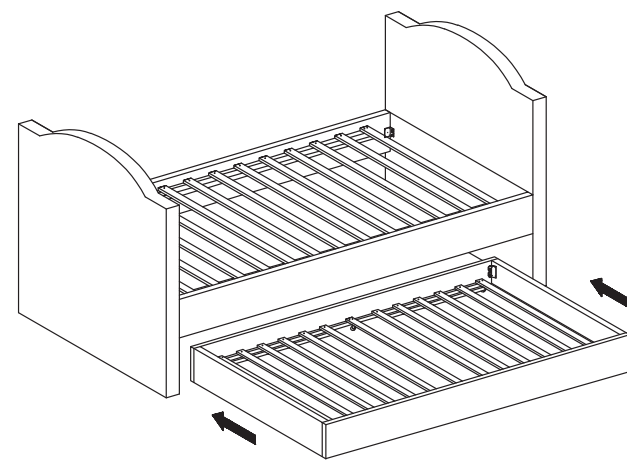

Your Day Bed is now ready for use.

Assembly Instructions

Contains One Bed and Hardware

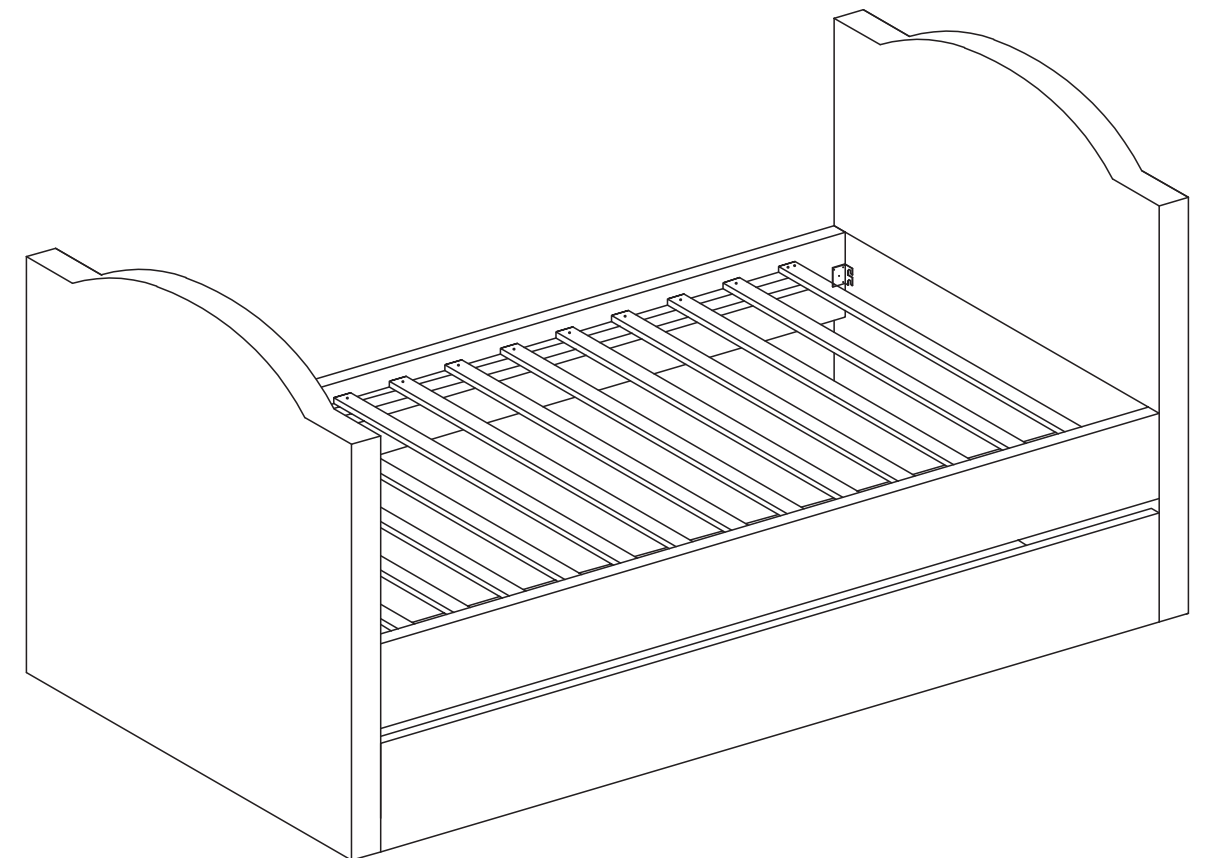

IMPORTANT NOTE:

Carefully remove all the parts from the box. Arrange on a flat surface and verify you have all of the following parts and hardware.

TOOLS REQUIRED:

Phillips Screwdriver

PARTS LIST

A. Arm (2 pcs)

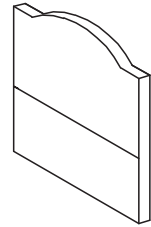

B. Roll Out Slats (1 pc)

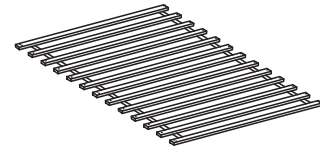

C. Front Side Panel (2 pc)

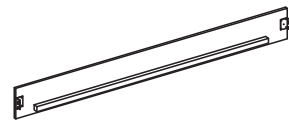

D. Trundle Front Panel (1 pc)

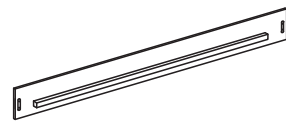

E. Trundle Back Panel (1 pc)

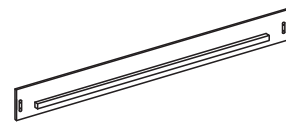

F. Trundle Side Panel (2 pcs)

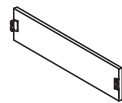

G. Trundle Slats (1 pc)

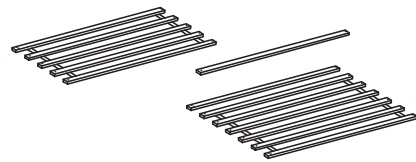

H. Wooden Block (4 pcs)

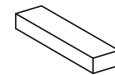

HARDWARE LIST

I. Hex Key (1 pc)

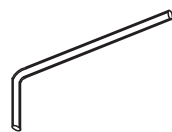

J. 32mm Screw (66 pcs)



K. 16mm Screw (24 pcs)



L. Roller (6 pcs)



ASSEMBLY INSTRUCTIONS

STEP 1

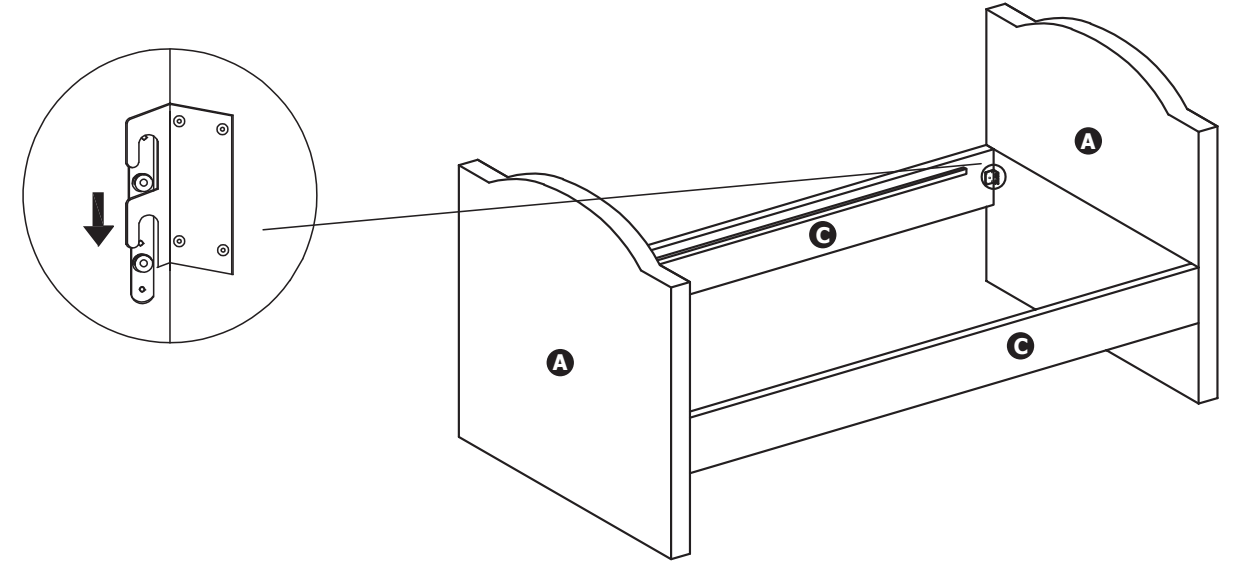

Attach Front Side Panels (Part C) to the two Arms (Part A) as shown.

STEP 2

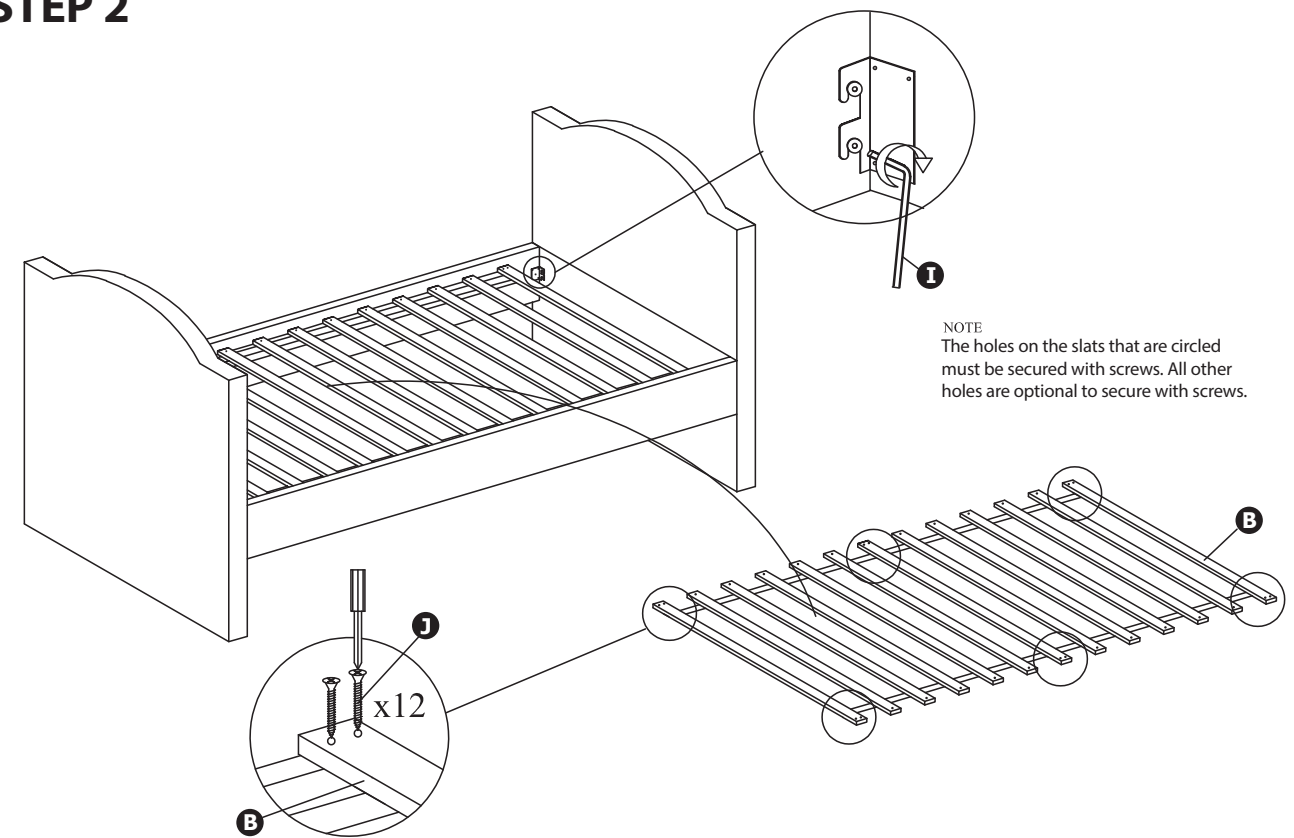

NOTE
The holes on the slats that are circled must be secured with screws. All other holes are optional to secure with screws.

Place the Roll Out Slats (Part B) on the runner boards of the side panels. Tighten the side panels to the arms using Hex Key (Part I). Secure the slats to the side panels using twelve 32mm Screws (Part J) in the holes that are circled.

(Continued on back)