

ASSEMBLY INSTRUCTIONS

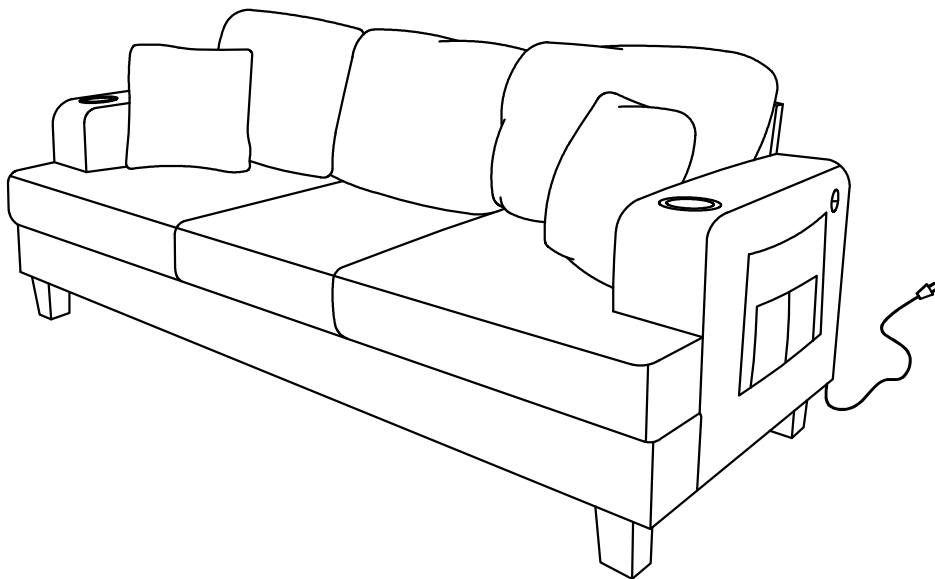

TOOLS REQUIRED

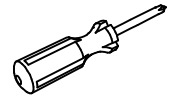

Screwdriver
(Not included)

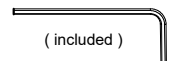

(included)

Allen Key

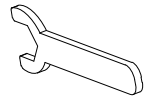

(included)

Allen Wrench

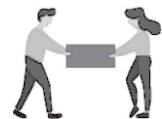

2 - People

ASSEMBLY RATING



EASY —————> DIFFICULT

The assembly rating is a 5-point system showing the level of effort needed to assemble a specific product.



CHECK BEFORE STARTING

Are you missing anything?

Double-check all parts, hardware and accessories listed are all accounted for.

Check out our Quick Tips!

We recommend reviewing the pre-assembly handouts. Even experts need a refresher now and then!

Should we send any replacements?

Are there any irregularities or flaws in the parts? We can send replacements!

Prep Time!

Please review the assembly instructions and all diagrams prior to assembling.

PRE ASSEMBLY INTRODUCTION

We understand building ready-to-assemble furniture can be a challenging experience for some. To help avoid confusion, we have provided some helpful tips that may speed up the process.

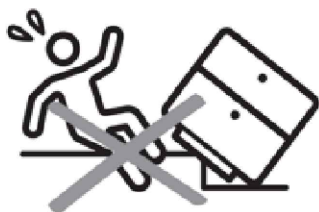
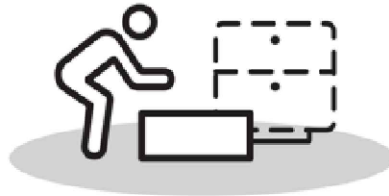
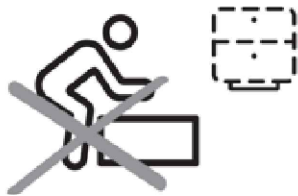
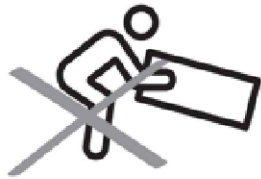

Teamwork

ALWAYS have at least two people to help with transporting and assembling the product to avoid potential injury and/or damage.

Suitable Location

Assembling near the area of the intended location is highly recommended.

Sufficient Space

Make sure you have enough space to move around during the assembly.

Avoid Scratches

Use cardboard, blankets or a carpeted area while assembling furniture to prevent scratches and damages.

Flat Surface

Make sure the furniture rests on a flat and level surface with each leg evenly touching the floor.

ASSEMBLY AND CARE ADVICE



FAILURE TO FOLLOW THE GUIDELINES BELOW MAY RESULT IN INJURY AND/OR PROPERTY DAMAGE.



Position each part correctly and insert screws or bolts into their respective holes.

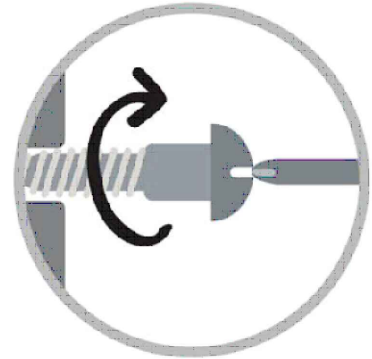

Turn clockwise to tighten and only tighten when step is completed or when instructed to do so.



Use the appropriate hand tools or power tools for assembly. Select steps, such as tightening screws and/or bolts, may require hand tools to avoid causing damage during assembly.



Save the instruction and store any supplied tools for later maintenance.

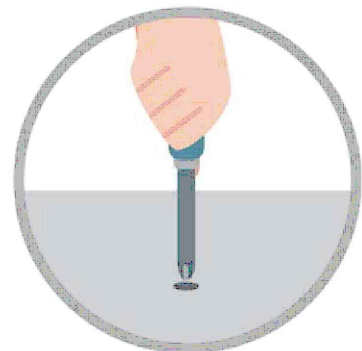

After two weeks, check and tighten any loose hardware and repeat again every six months thereafter.

IT IS THE USER'S RESPONSIBILITY TO MAINTAIN THE FURNITURE. THE HARDWARE MAY LOOSEN OVER TIME AND MAY CAUSE THE FURNITURE TO BE WOBBLY AND UNABLE TO SUPPORT ITS INTENDED WEIGHT CAPACITY. THIS MAY LEAD TO COLLAPSE AND MAY CAUSE SERIOUS INJURY.

Sofa



- Please keep instructions for future reference.
- Check the quantity and irregularity of parts and hardware before you start.

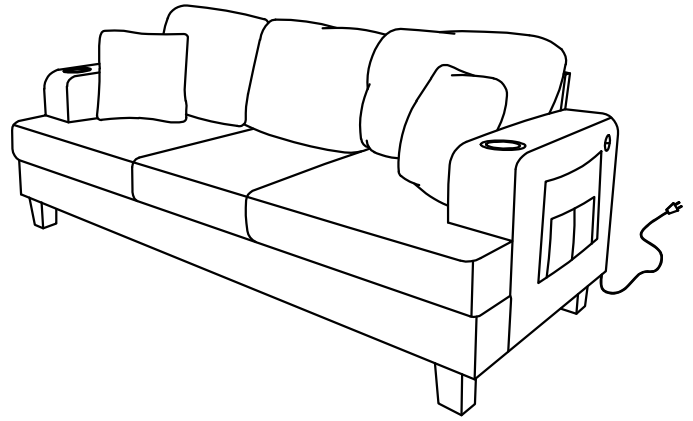

PARTS

① 2pcs



SUPPORT RAILS

② 1pc



BACK PANEL

③ 1pc



FRONT PANEL

④ 1pc

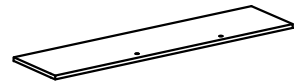

SEATS FRAME

⑤ 1pc

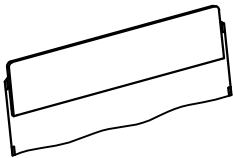

BACKREST FRAME

⑥ 1pc

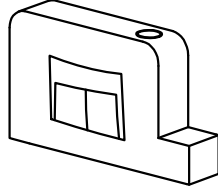

ARMREST LEFT

⑦ 1pc

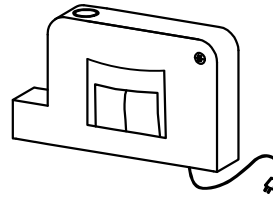

ARMREST RIGHT

⑧ 4pcs

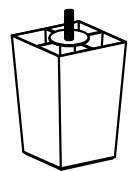

LEGS

⑨ 2pcs



MIDDLE SUPPORT LEGS

⑩ 1pc

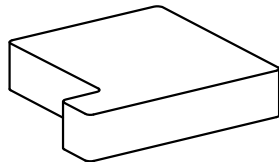

RIGHT SEAT CUSHION

⑪ 1pc

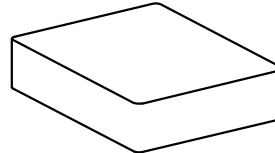

MIDDLE SEAT CUSHION

⑫ 1pc

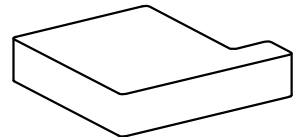

LEFT SEAT CUSHION

⑬ 3pcs



BACK CUSHIONS

⑭ 2pcs

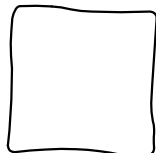

PILLOWS

⑮ 1pc



FRONT PANEL COVER

HARDWARE

(A) 8pcs



BOLT: 5/16" X 25MM

(B) 5pcs

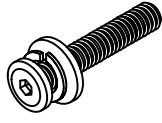

BOLT: 5/16" X 50MM

(C) 1pc



ALLEN KEY: L5

(D) 4pcs

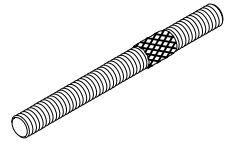

THREADED ROD: 5/16" X 80MM

(E) 4pcs



HEXAGONAL NUT: 5/16"

(F) 4pcs

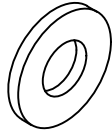

FLAT WASHER: 5/16"

(G) 4pcs







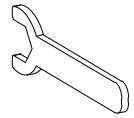



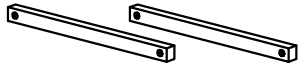





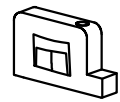

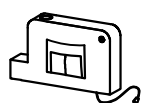



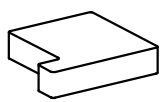

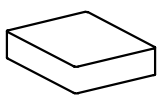
SPRING LOCK WASHERS:
5/16"

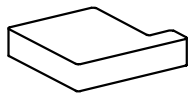
(H) 1pc



ALLEN WRENCH
5/16"

Carton	Designation	Part	Hardware
01	Support rails	#1 	
	Back panel	#2 	
	Front panel	#3 	
	Seats frame	#4 	
	Backrest frame	#5 	
	Middle support legs	#9 	
02	Armrest left	#6 	 #A 8pcs
	Armrest right	#7 	 #B 5pcs
	Legs	#8  x 4	 #C 1pc
	Right seat cushion	#10 	 #D 4pcs
	Middle seat cushion	#11 	 #E 4pcs
	Left seat cushion	#12 	 #F 4pcs
	Back cushions	#13  x 3	 #G 4pcs
	Pillows	#14 	 #H 1pc
	Front panel cover	#15 	

ASSEMBLY INSTRUCTIONS

- 1 Take the Pillow (14), Back Cushion (13), Blister Hardware out from the Armrest Right (7). Velcro the bottom of the Armrests.

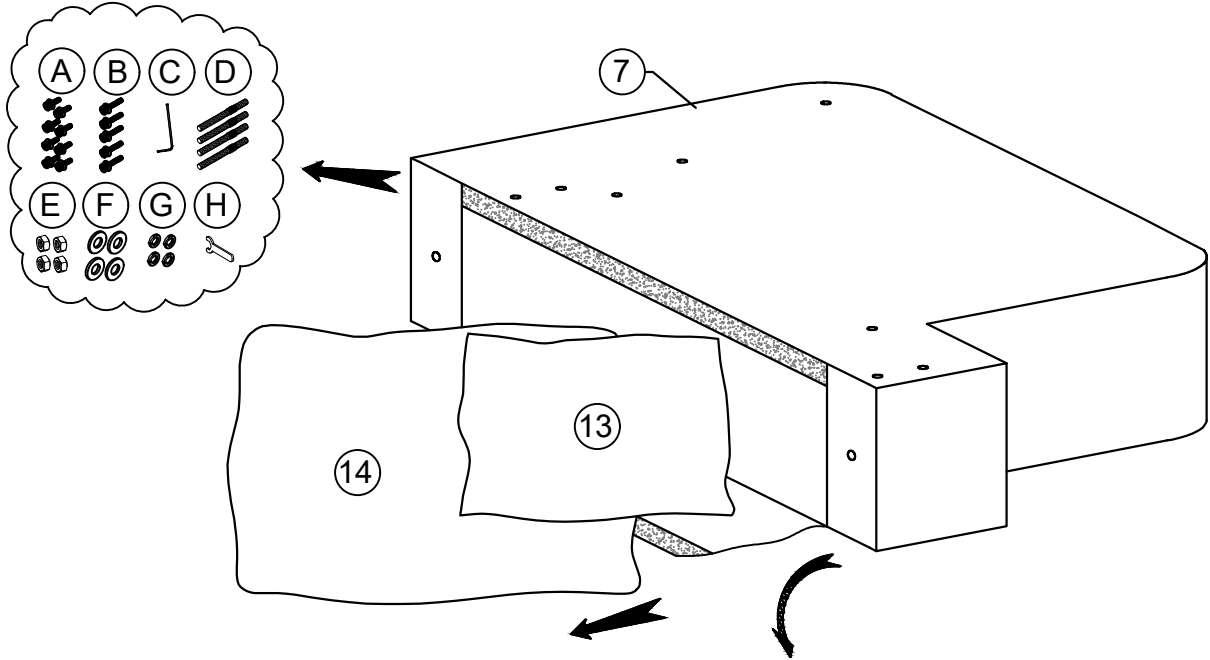

- 2 Take the Pillow (14), Back Cushion (13) out from the Armrest Left (6). Velcro the bottom of the Armrests.

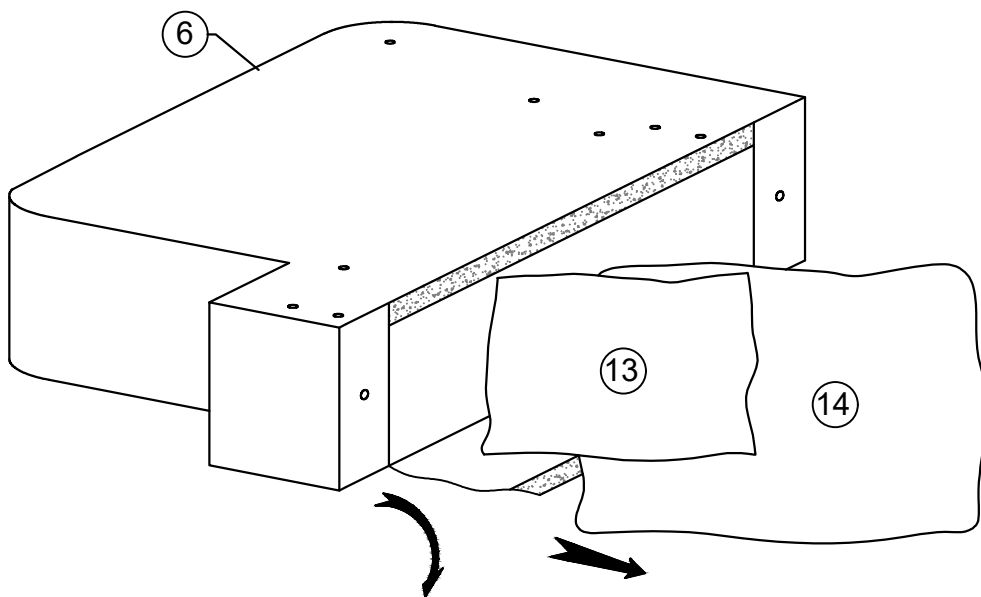

ASSEMBLY INSTRUCTIONS

- 3** Open the Seat Cushions (10, 11, 12), Back Cushions (13) and Pillows (14) by suitable tools.
Note: Cushions need 48 hours to bounce back.

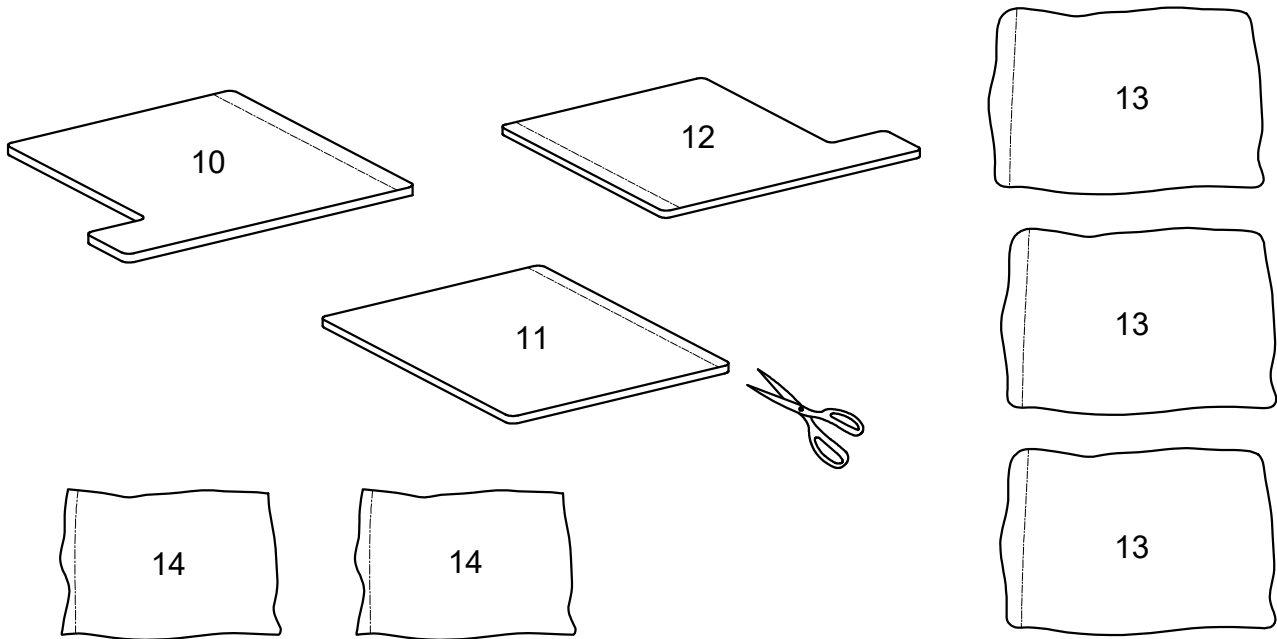

- 4** Close the Velcro. Attach the sofa Legs (8) to the Armrests (6 / 7).

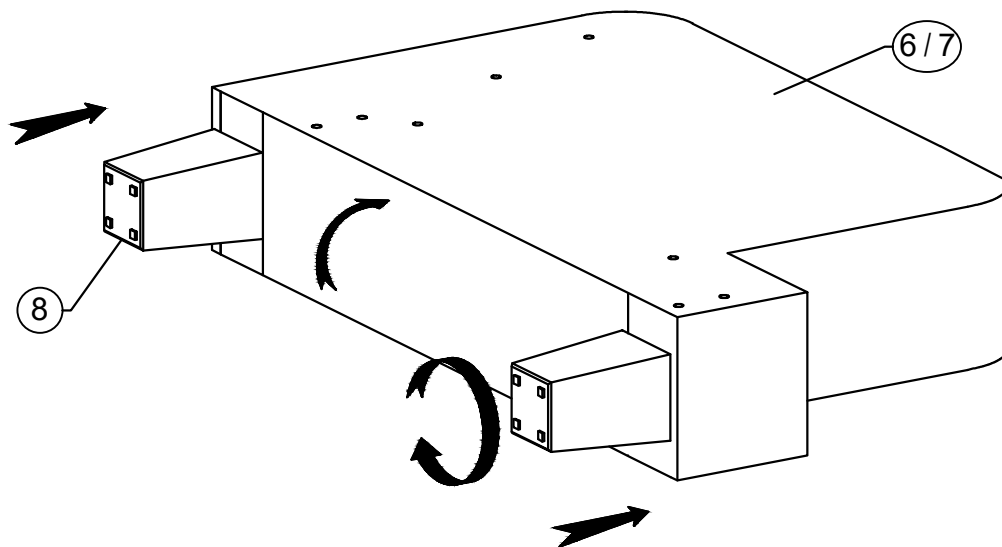

ASSEMBLY INSTRUCTIONS

- 5** Attach the Support Rails (1) to the Armrests (6 / 7) by the Bolt 5/16" x 50mm (B) and Allen Key (C).

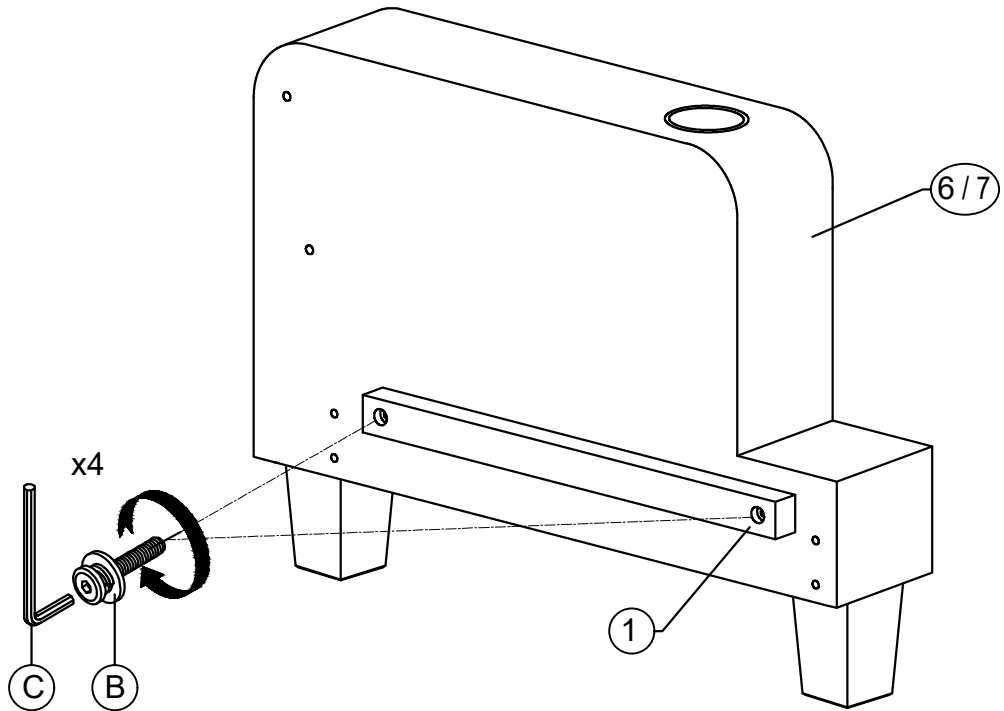

- 6** - Align and insert the Threaded Rod 5/16" x 80mm (D) into the hole on the Armrests and turn clockwise to tighten by manually.
- Insert Bolts 5/16" x 25mm (A) with Allen Key (C) on the Armrests by manually. NOTE: Do not fully tighten the bolts, leave at least 10mm visible so that you can hanger hook on the bolts.

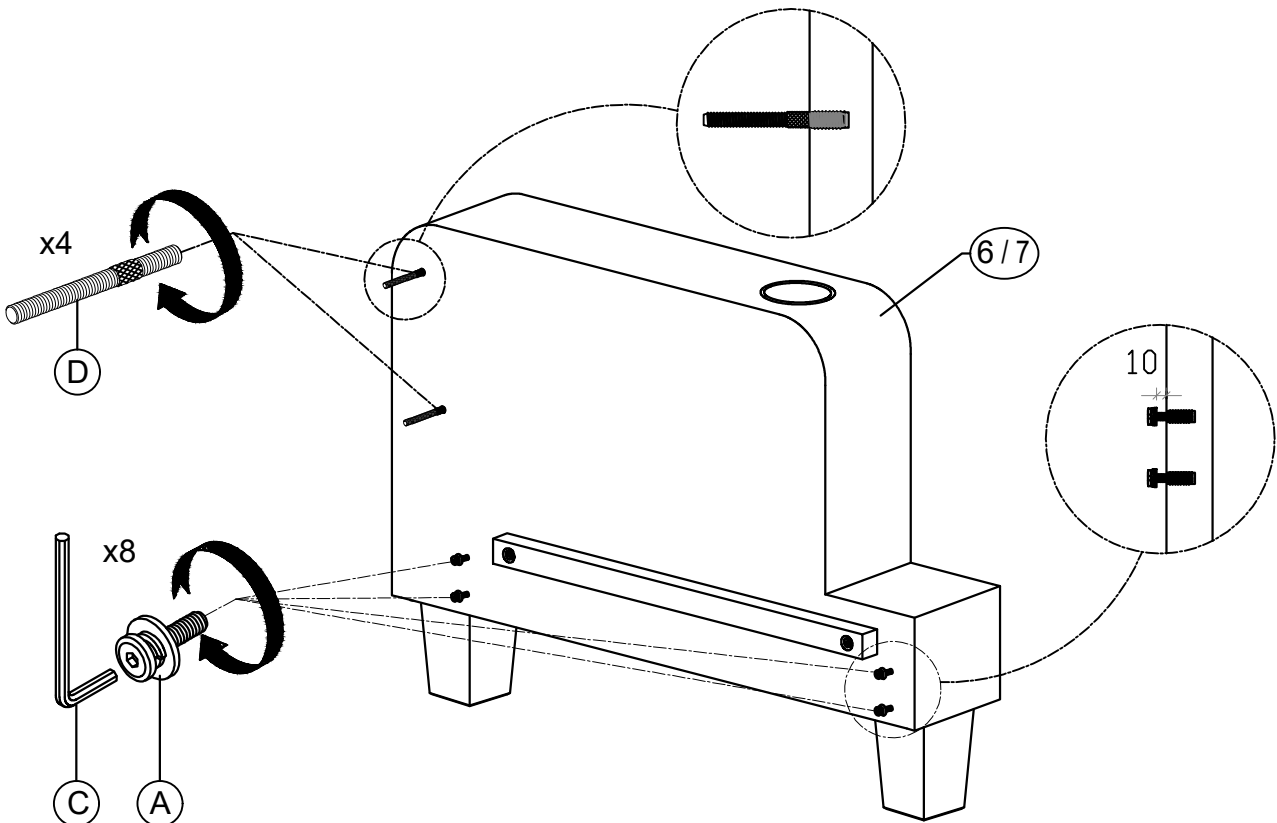

ASSEMBLY INSTRUCTIONS

- 7** Overturn back cover, open zipper
Raise the Backrest Frame (5) up and place the rod (D) to align with the bore holes on the end of the Backrest Frame (5). Put the Backrest Frame (5) up against the Armrests (6 / 7) so the threaded rods (D) go through the bore holes. Insert flat washer (F), spring lock washers (G) and place hex nuts (E) on threaded rod (D) then tighten the hex nuts (E) with wrench (H) provided. Do not fully tighten the hex nuts, equally distance divided on both sides.

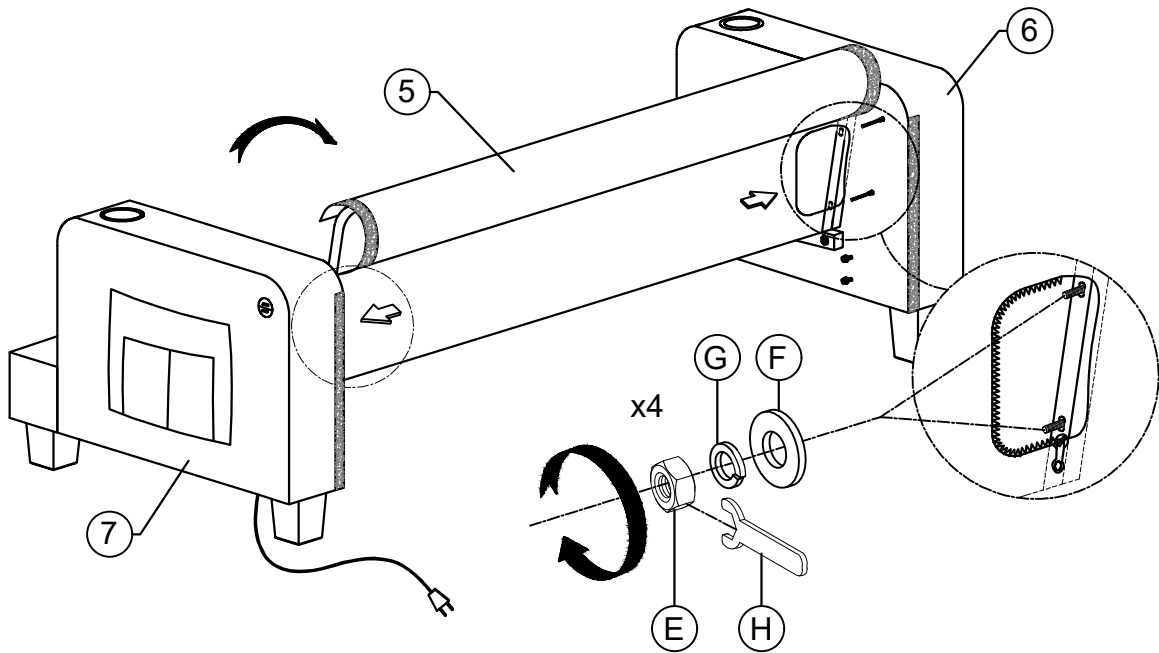

- 8** Raise the Front/Back Panels (2 / 3) up, bring the Front/Back Panels (2 / 3) and align the hook on the side rail to the bolts. Once the Front/Back Panels (2 / 3) is set, tighten all bolts by using a Allen key (D). After assembly, re-tighten all bolts for a snug fit. **DO NOT OVER TIGHTEN.**

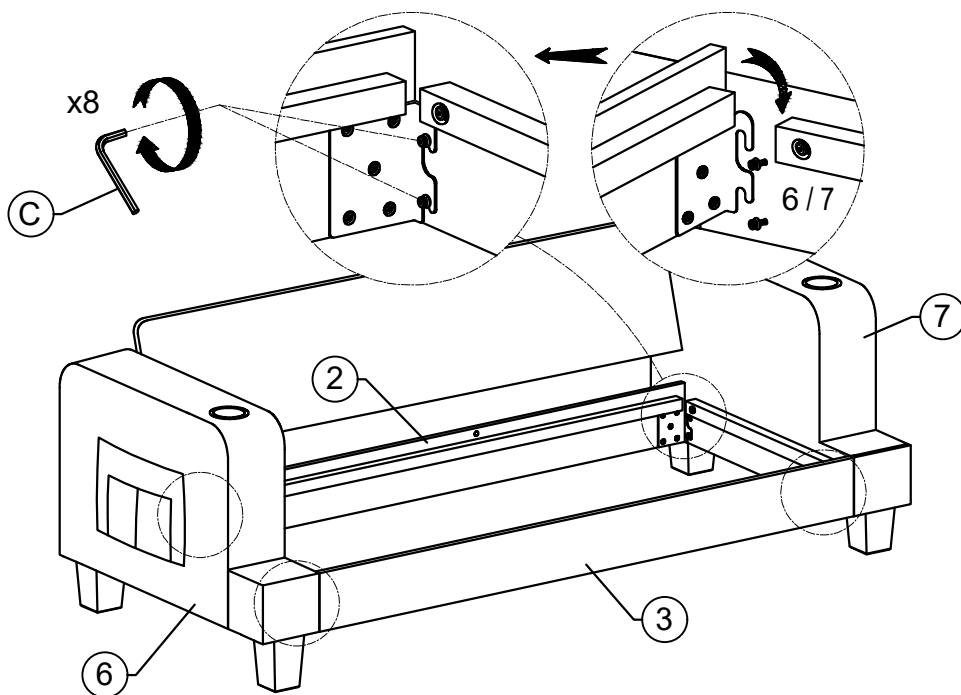

ASSEMBLY INSTRUCTIONS

- 9** After assembly, re-tighten all bolts for a snug fit.
Close the Zipper
Close Velcro the cover of Backrest Frame (5) and Armrest (6 / 7).

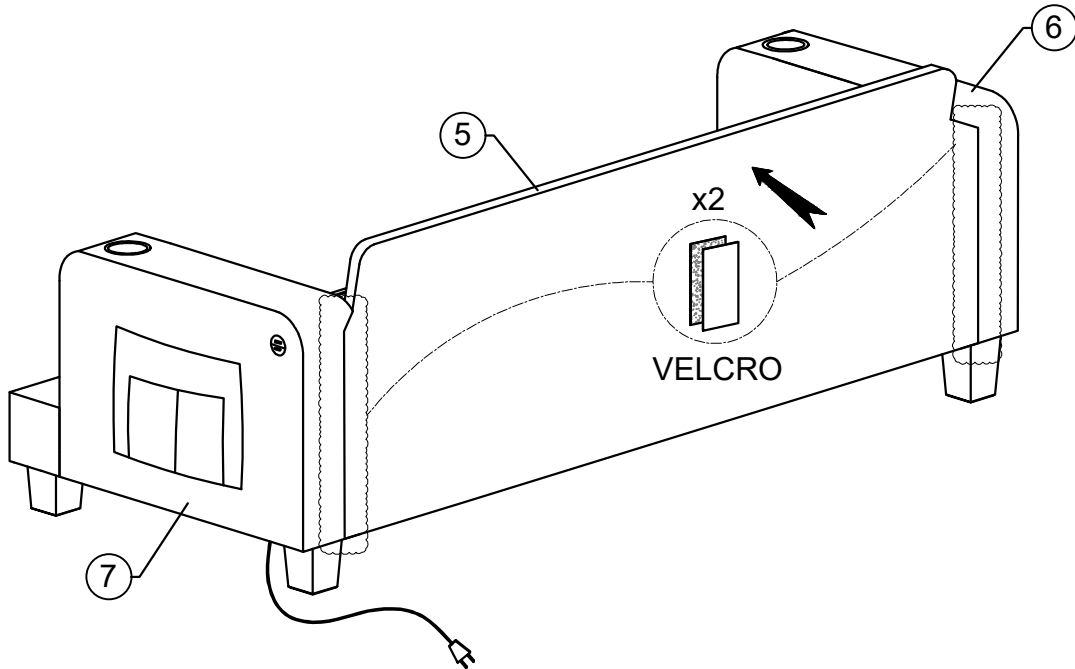

- 10** Attach the Front Panel Cover (15) by Velcro.

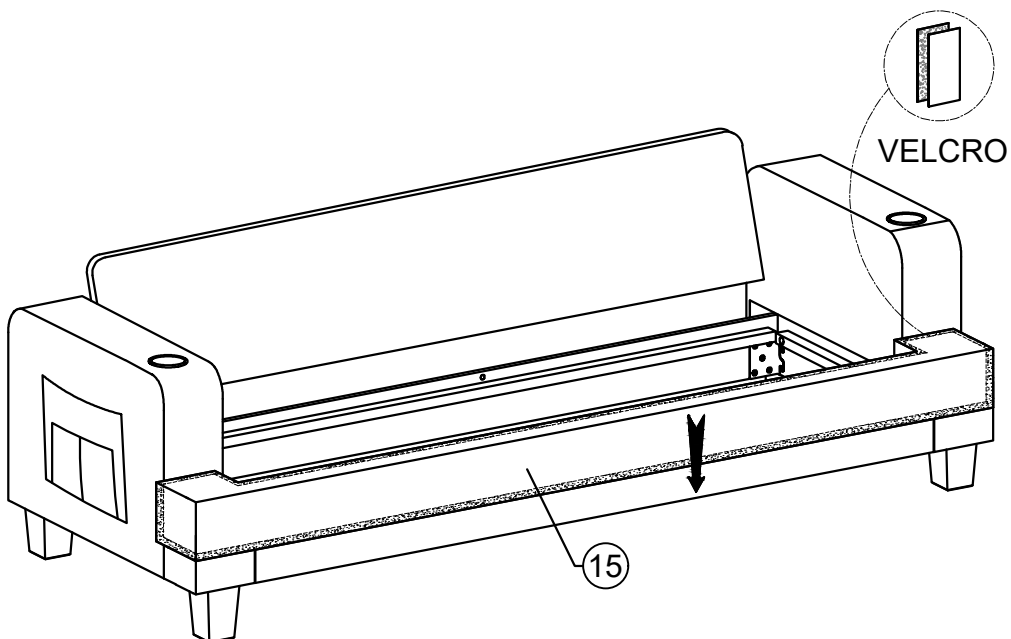

ASSEMBLY INSTRUCTIONS

11 Attach the Middle Support Legs (9) to the Seat Frame (4).

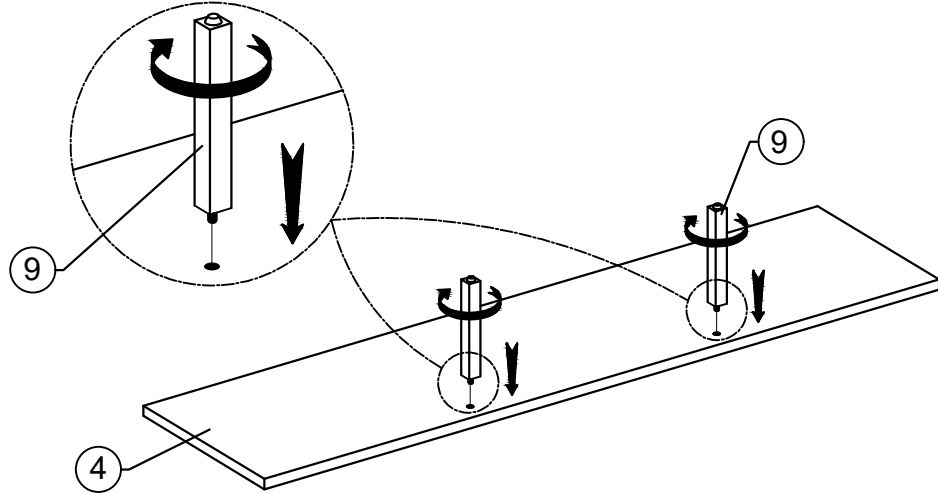

12 Drop Seat Frames (4) to the Armrest (6 / 7). Attach the Seat Frames (4) to the Back panel (2) by the Bolt 5/16" x 50mm (B) and Allen Key (C).

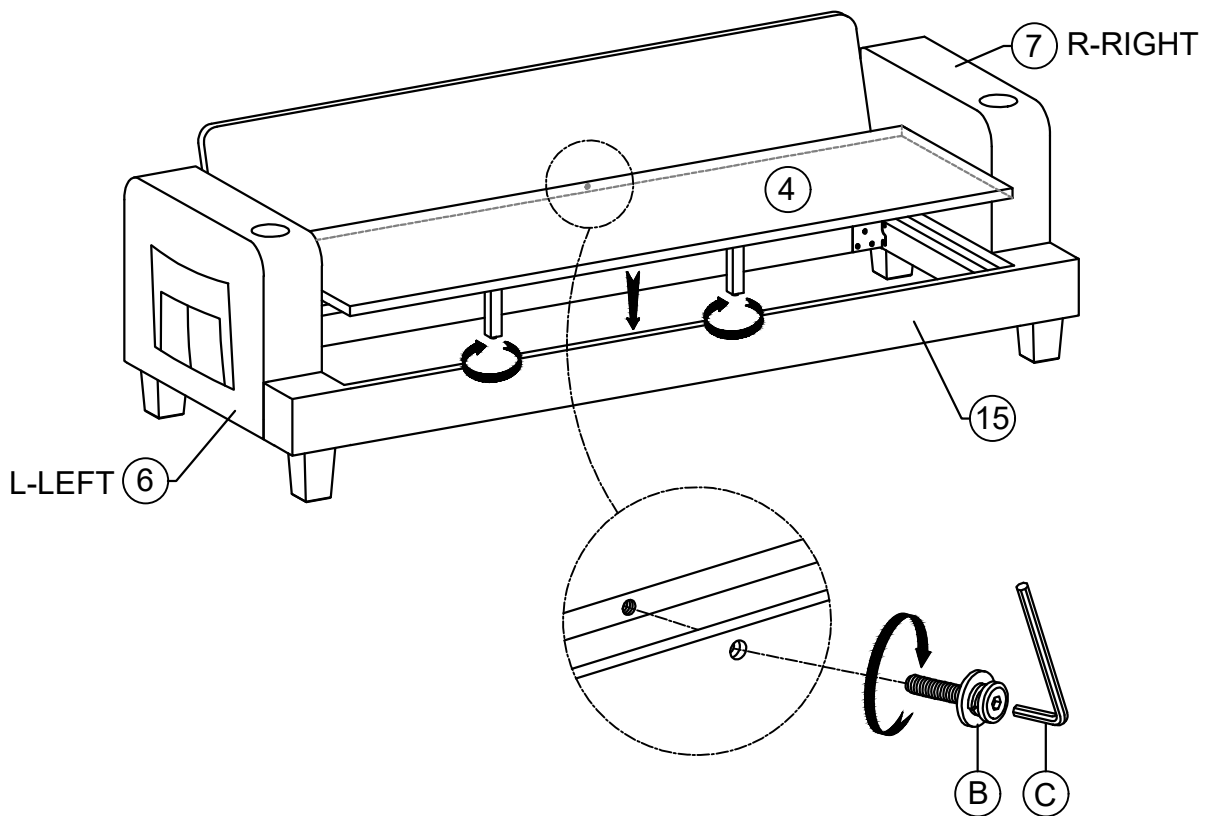

ASSEMBLY INSTRUCTIONS

13 Insert the Seat Cushions.

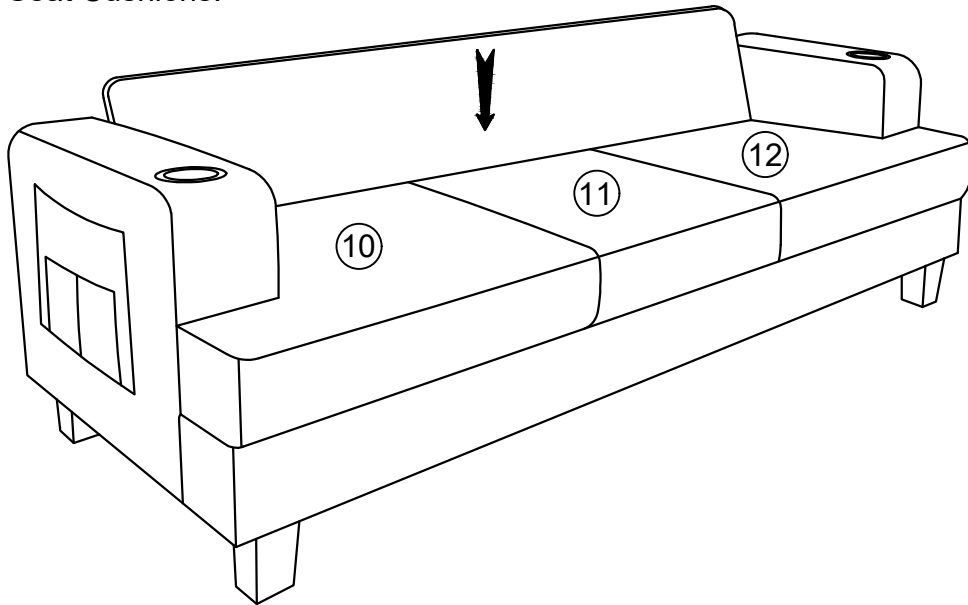

14 Insert the Back Cushions and Pillows.

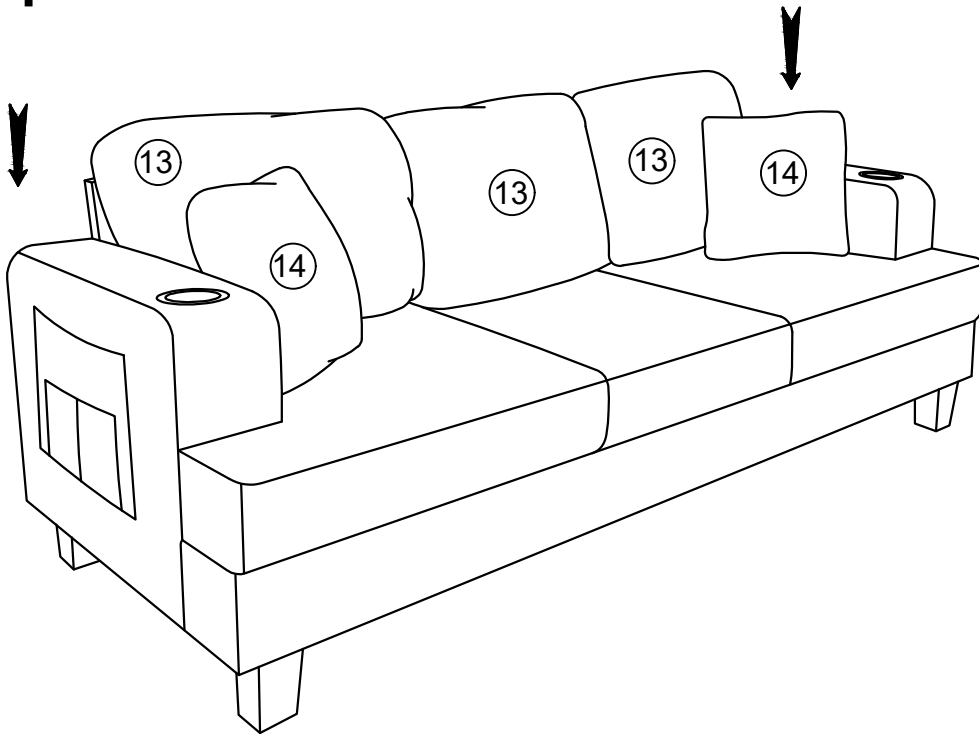

ASSEMBLY COMPLETED



Please ensure the furniture rests on an even and flat surface. If the product wobbles or feels loose, double-check all bolts and/or screws are properly tightened and secured.

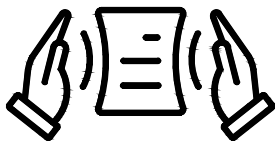

Compressed Transport

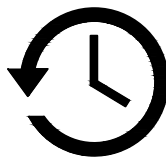

Unpack and wait 48 hours for recovery

✓ Keep this handy!

Please retain this instruction manual and any order-related information for future reference.

✓ Lift, don't drag!

To avoid damage to product please always LIFT the product when transporting or adjusting the placement.

This product is intended for RESIDENTIAL USE ONLY and not for commercial use.