

- Il contatto prolungato con sostanze pur blandamente aggressive, può determinare il danneggiamento della treccia ed il conseguente scoppio del flessibile.
- Prolonged contact with any substance, even scarcely aggressive, can cause external braid damage and subsequent flexible burst.
- Le contact prolongé avec des substances, même peu agressives, il peut déterminer l'endommagement de la tresse et l'éclat conséquent du flexible.
- Der anhaltende Umgang mit Stoffen, die auch zart aggressiv wirken können, kann zur Beschädigung des Geflechtes und infolgedessen zum Rohrbruch führen.

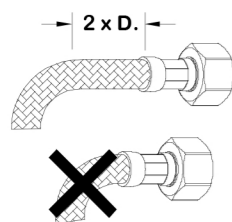

- Prima dell' inizio della curvatura lasciare un tratto rettilineo di almeno 2 volte il diametro esterno.
- Before bending the hose please consider a straight part of 2 times the external diameter.
- Avant le commencement de la courbure laisser une ligne rectiligne d'au moins 2 fois le diamètre extérieur.
- Vor dem Beginn der Biegung stellen Sie sicher, dass es einen geradlinigen Abschnitt gibt, dessen Länge mindestens zweimal höher als der Außendurchmesser sein soll.

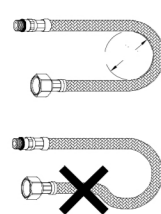

- Rispettare il raggio minimo di curvatura (DN= diametro interno nominale):
- Maintain minimum bend radius (DN= nominal internal diameter):
- Respecter le rayon minimum de courbure (DN= diamètre interne nominale):
- Halten Sie den mindeste Biegungshalbmesser ein (DN= Innerer nominell Durchmesser):

DN6 = 50mm DN10 = 70mm
DN8 = 60mm DN13 = 90mm

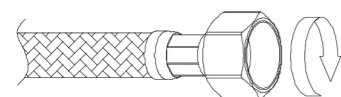

- Avvitare i raccordi con tenuta a guarnizione (dadi) a mano fino a che possibile, più 1/4 di giro con chiave appropriata.
- Hand-tighten connectors with gasket seal (nuts) as more as possible, then apply 1/4 turn using an appropriate wrench.
- Visser les raccords avec le joint d'étanchéité (écrous) à la main le plus possible, plus 1/4 de tour avec une clé appropriée.
- Schrauben Sie die Rohranschlüsse mit Dichtung (Schraubenmutter) erstens von Hand, und danach um 90° mit einem geeigneten Schlüssel ein.

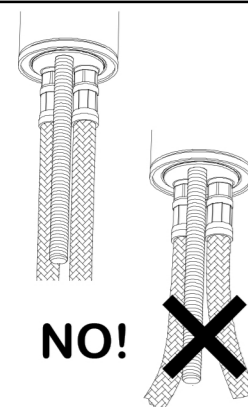

- Dopo il montaggio evitare sollecitazioni laterali ancheminime. (es. durante il fissaggio del tirante).
- Do not expose the hose to lateral stress nor overtight by any tool. (ex. during the installation of the faucet stud).
- Après le montage il faut éviter des sollicitations latérales même moindres, avec n'importe quel outil. (ex. pendant la fixation du tirant).
- Nach der Montage, vermeiden Sie auch die mindesten lateralen Spannungen, mit Werkzeugen jeglicher Art (z.B. Bei dem Festklemmen der Spannstange).

CONSIGLI DI PULIZIA - CLEANING TIPS

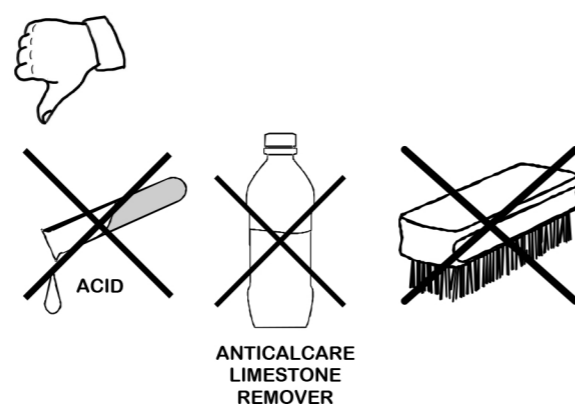
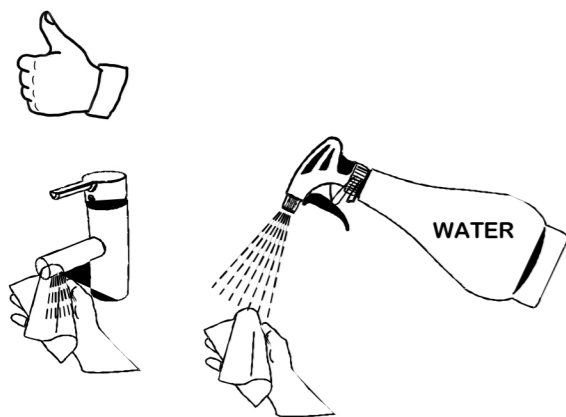

Installation Instructions

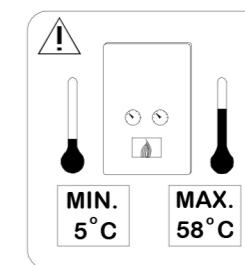
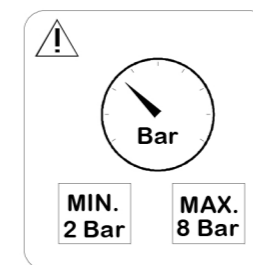
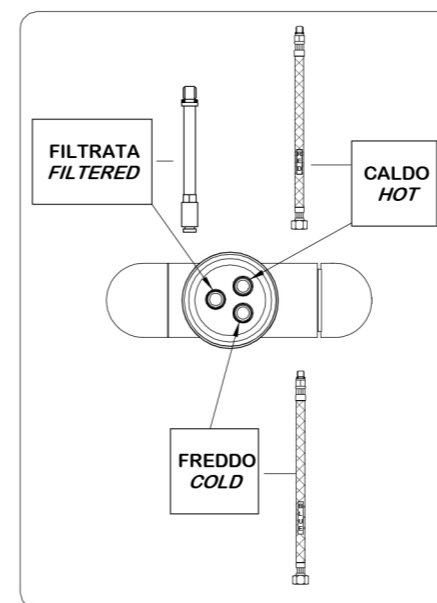

COME CONNETTERE IL TUBO AL RACCORDO JOHN GUEST

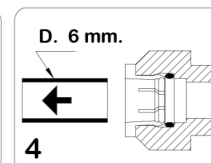
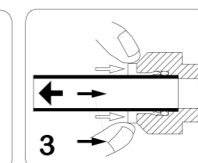
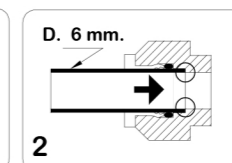
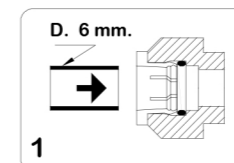

UNA VOLTA INSERITO IL TUBO TIRARE DELICATAMENTE PER ACCERTARE LA TENUTA

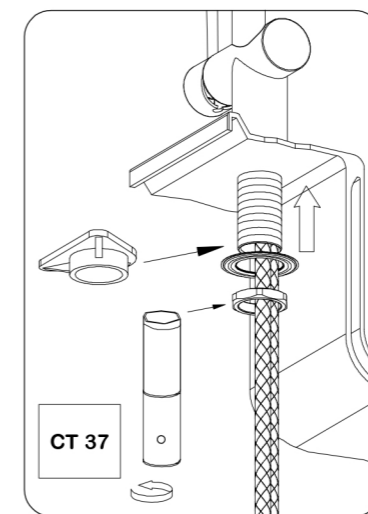
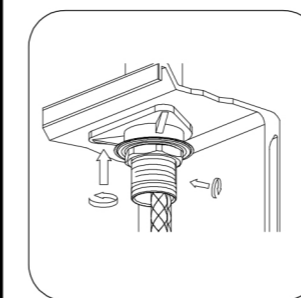
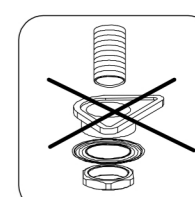
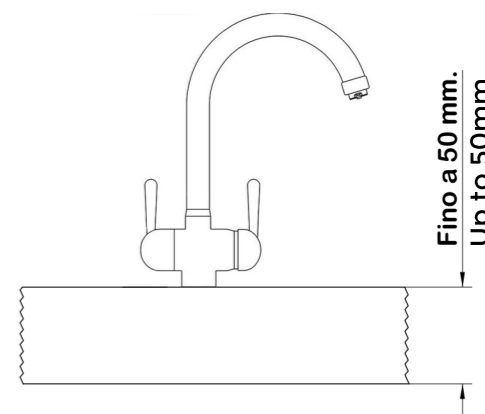
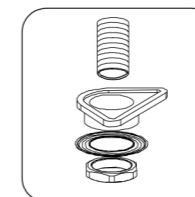
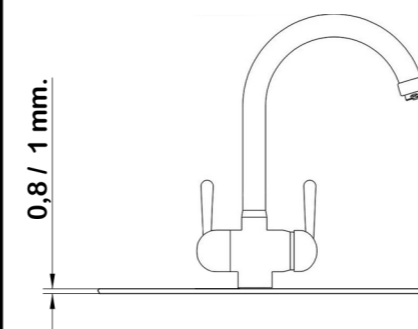

www.hommix.co.uk
info@hommix.co.uk

0330 113 9292

077 8080 5720
(WhatsApp Business)