

# HAPPINESS HAPPINESS INSTALLATION



- If you have any questions with the product, please contact us by:
- **Email: [customerservice@zoy-living.com](mailto:customerservice@zoy-living.com)**  
(we will reply to you within 24 hours)

# Assembly Instruction







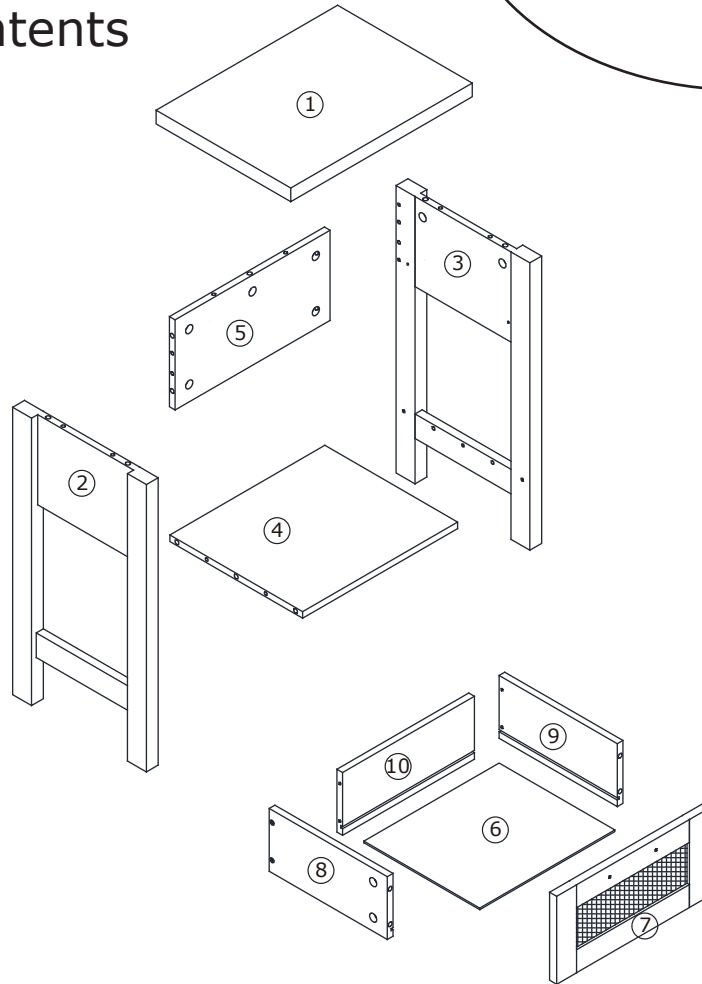

## WB001GD2029

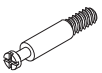
Your product comes packaged in one box. Carefully remove all of components from the packaging and set aside for assembly.

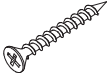

**CAUTION**  
**DO NOT** use any sharp objects to open plastic wrapped components as this may result damage to product or components .

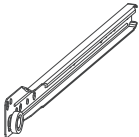
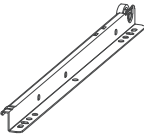
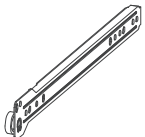
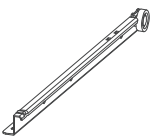
## Package Contents

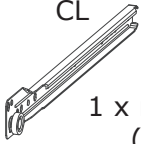
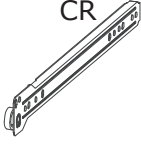

Ax 19 (+2pcs spare)  Ø6x36 mm	Bx 19 (+2pcs spare)  Ø15x9.5 mm	Cx 14 (+2pcs spare)  Ø5.8x30 mm	Dx 1 	Ex 8 (+1pc spare)  Ø3.5x12 mm	Fx 4 (+1pc spare)  Ø4x35 mm
Gx 2 (+1pc spare)  Ø4x16 mm	Hx 1 (CL) 	(DL) 	(CR) 	(DR) 	Lx 4 (+1pc spare) 

# Step 1

You will need	
 CL  CR 1 x runner (H)	
 4 x Screws (E)	 Phillips head Screwdriver



Assemble 1x drawer runner CL to left side panels (2) with 2x screws (E) using a Phillips head screwdriver, follow the runner direction and screw holes as shown.

Assemble 1x drawer runner CR to right side panels (3) with 2x screws (E) using a Phillips head screwdriver as shown.

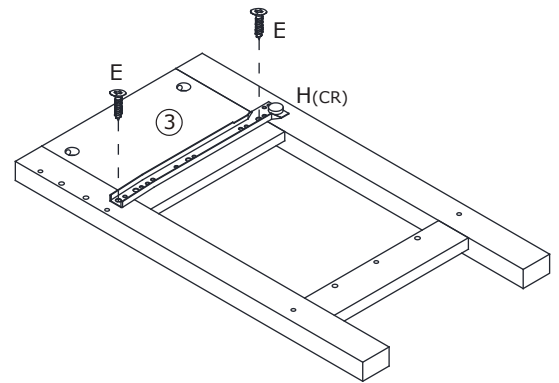
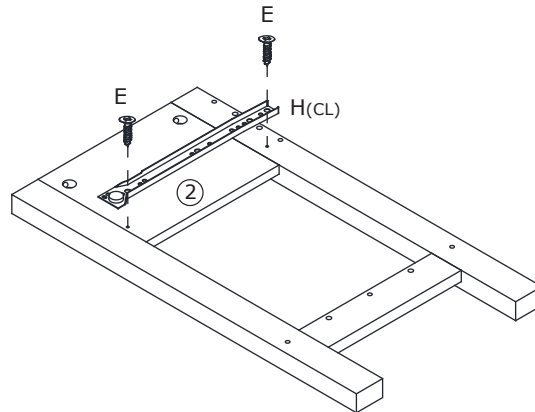
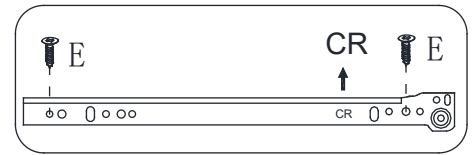
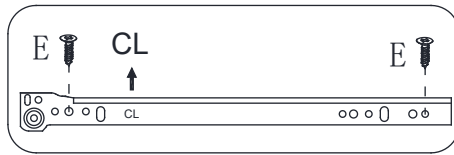
**Note:** CL and CR marks are stamped on runner tracks.

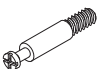

# Step 2

You will need	
 19 x Bolts (A)	 4 x Fiber Feet (L)
 Phillips head Screwdriver	



Put panels on the carpet or soft surface.

Screw 19 x cam bolts (A) into side panels (2) and (3), drawer front (7) and top panel (1) using a Phillips head screwdriver.

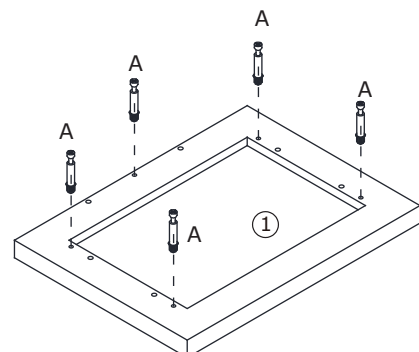
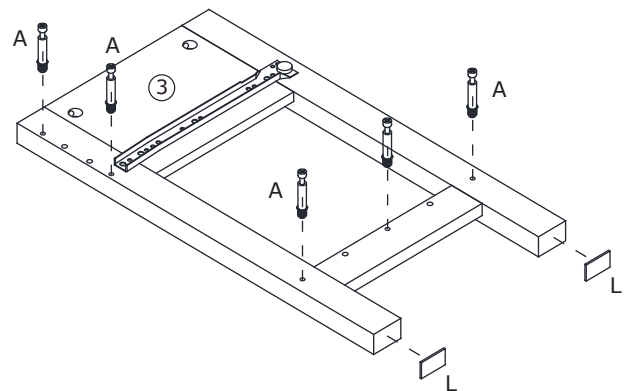
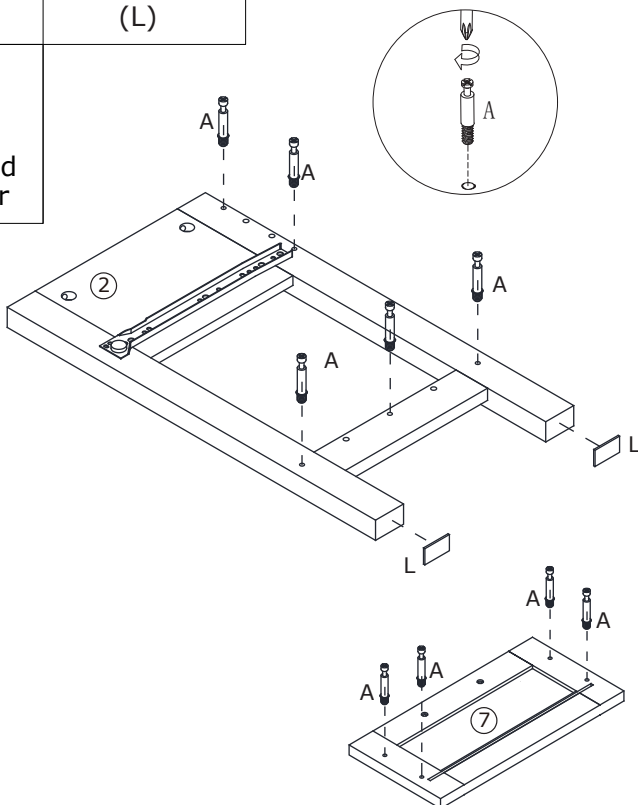
Paste 4x Fiber Feet onto legs bottom.



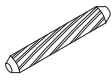

## Step 3

You will need	
 5 x cam nuts (B)	 4 x Dowels (C)
 Flat head screwdriver	

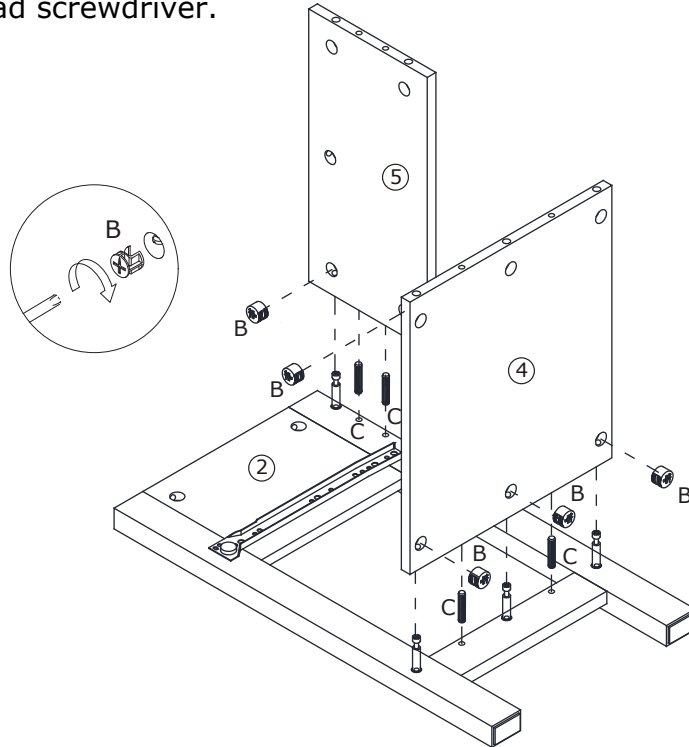
Insert 4 x dowels (C) into the left side panels (2) .  
Position bottom panel (4), back panel (5) onto left side panel (2) as shown.  
Insert 5x cam nuts (B) into bottom panel (4) and back panel (5) , rotate the cam nuts clockwise to lock the cam bolts by using a flat head screwdriver.



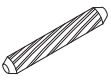

## Step 4

You will need	
 5 x cam nuts (B)	 4 x Dowels (C)
 Flat head screwdriver	

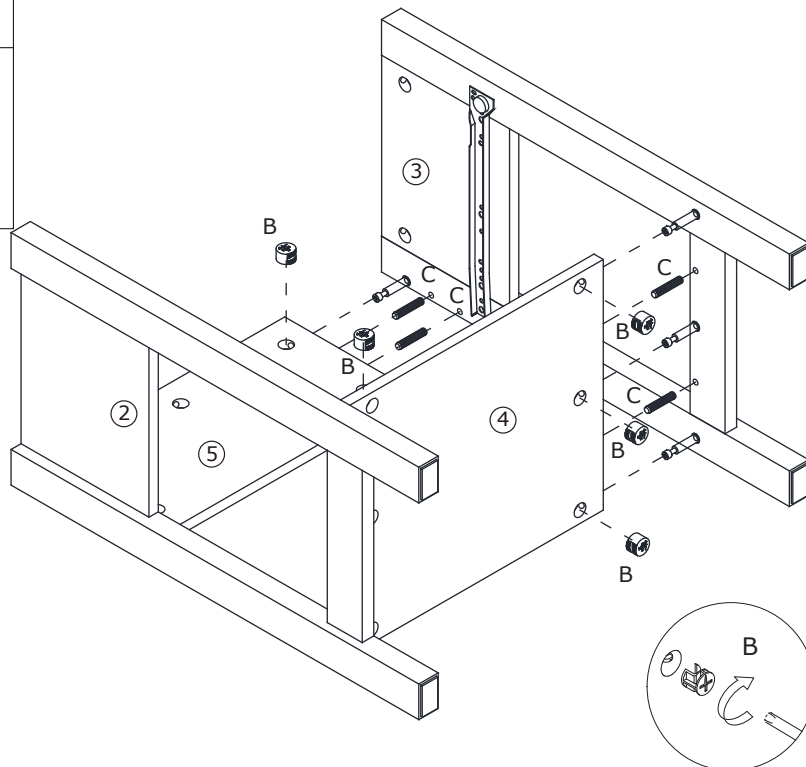
Insert 4 x dowels (C) into bottom panel (4), back panel (5) , position right side panel (3) onto assembled frame.  
Insert 5 x cam nuts (B) into bottom panel (4) and back panel (5) as shown, rotate the cam nuts clockwise to lock the cam bolts by using a flat head screwdriver.

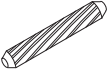

## Step 5

You will need	
 5 x cam nuts (B)	 6 x Dowels (C)
 Flat head screwdriver	



With help, stand the unit upright.

Insert 6 x dowels (C) into back panel (5) and side panels (2) and (3), position top panel (1) onto assembled unit.

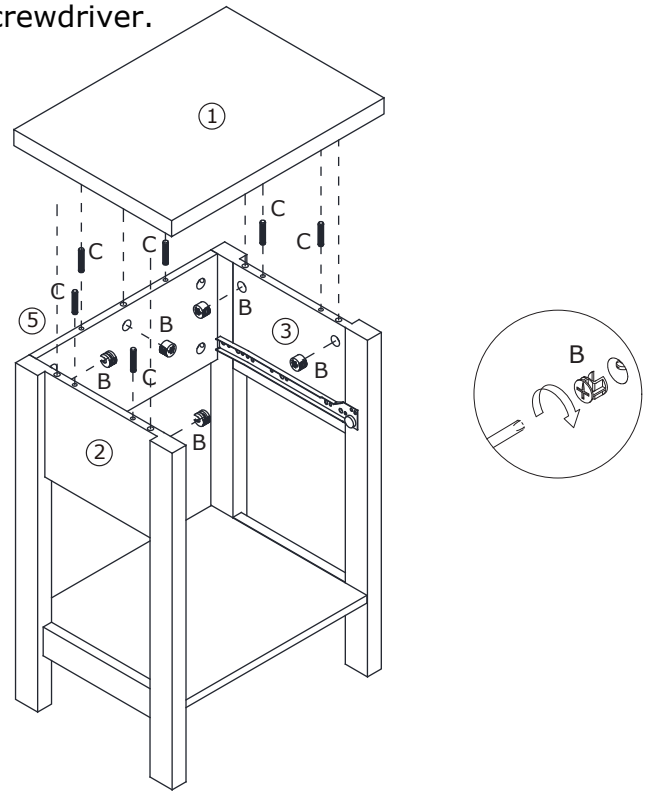
Insert 5x cam nuts (B) into back panel (5) and side panels (2) and (3) as shown, rotate the cam nuts clockwise to lock the cam bolts by using a flat head screwdriver.





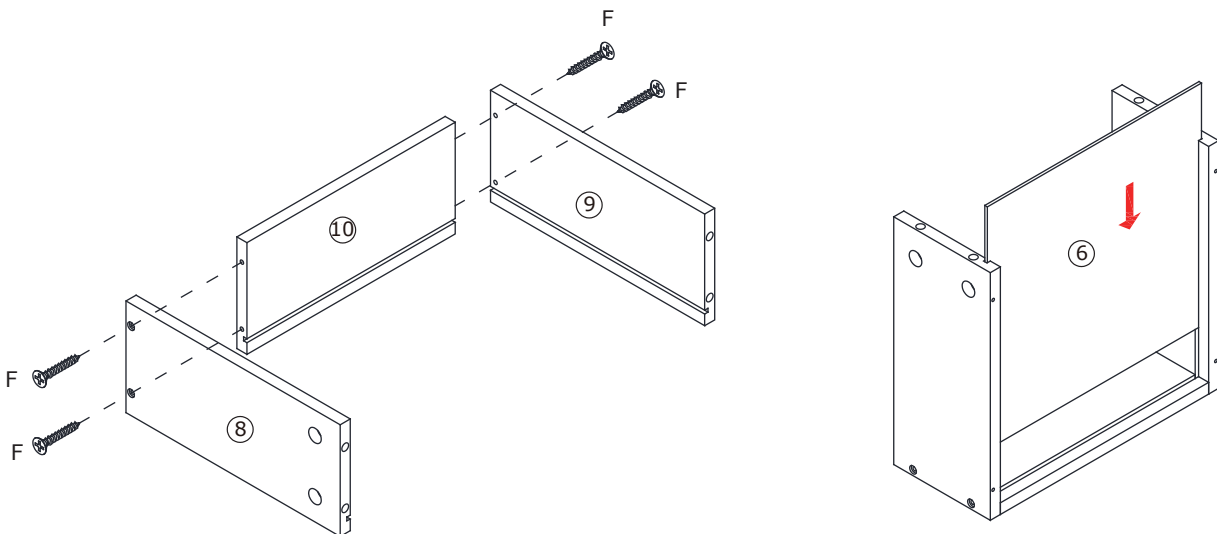

## Step 6

You will need	
 4 x Screws (F)	 Phillips head Screwdriver

Assemble drawer side panels (8) and (9) onto drawer back panel (10) with 4x screws (F), watch the grooves are at same side. Slide drawer base (6) into grooves of panels (8),(9) and (10).



# Step 7



You will need	
 4 x Cam nuts (B)	 1 x handle (D)
 2 x Screw (G)	 Flat head screwdriver
 Phillips head Screwdriver	

Position the drawer front (7) onto assembled drawer box as shown. Insert 4x cam nuts (B) into drawer side panels (8) and (9), rotate the cam nuts clockwise to lock the cam bolts by using a flat head screwdriver.

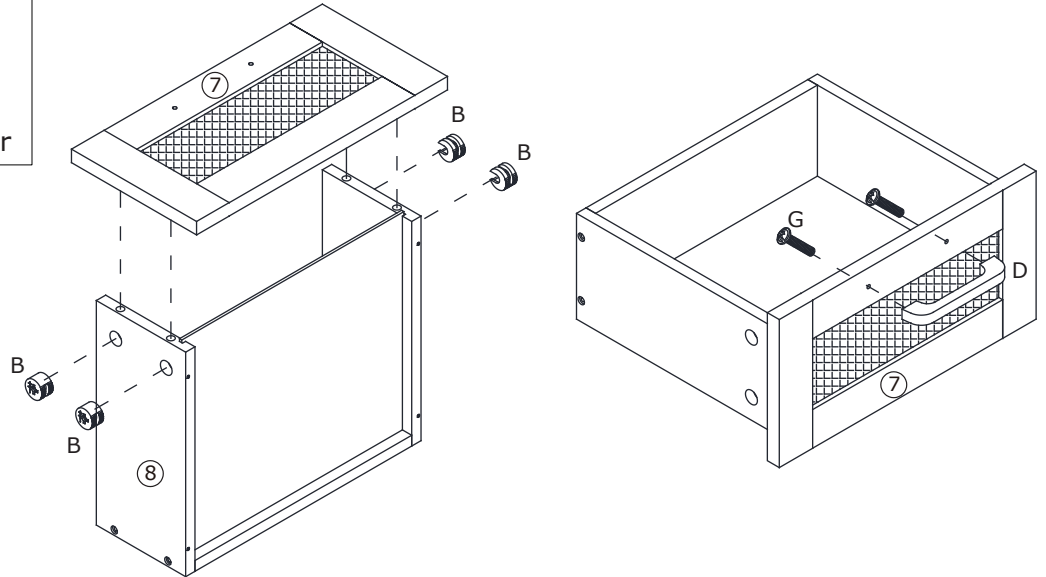
Assemble 1x drawer handle (D) onto drawer front (7) with 2x screw (G).

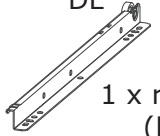
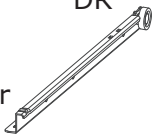

# Step 8

You will need	
 DL	 DR
1 x runner (H)	
 4 x Screws (E)	 Phillips head Screwdriver

Assemble the drawer runners DL and DR to drawer side panels (8) and (9) with 4x screws (E) using a Phillips screwdriver .

Follow the runner direction and screw holes as shown.

**Note:** DL and DR marks are stamped on runner tracks.

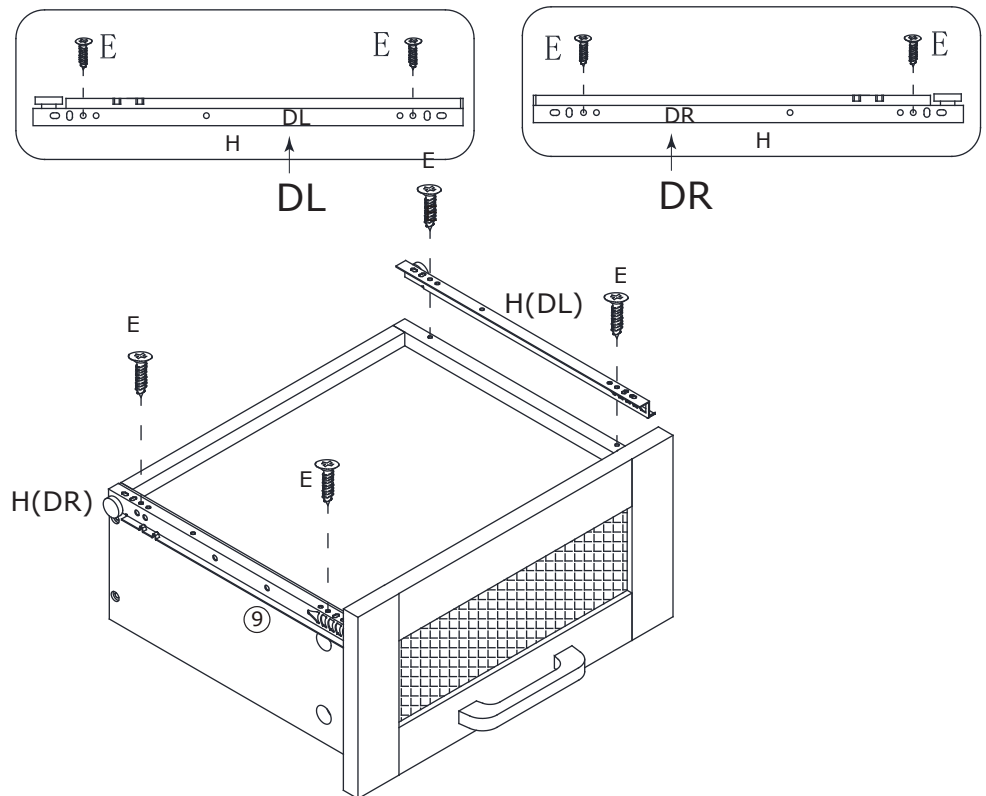

## Step 9

Tilt the drawer a bit , gently insert the drawer into cabinet , make sure the runners on drawer sliding into the tracks of cabinet.

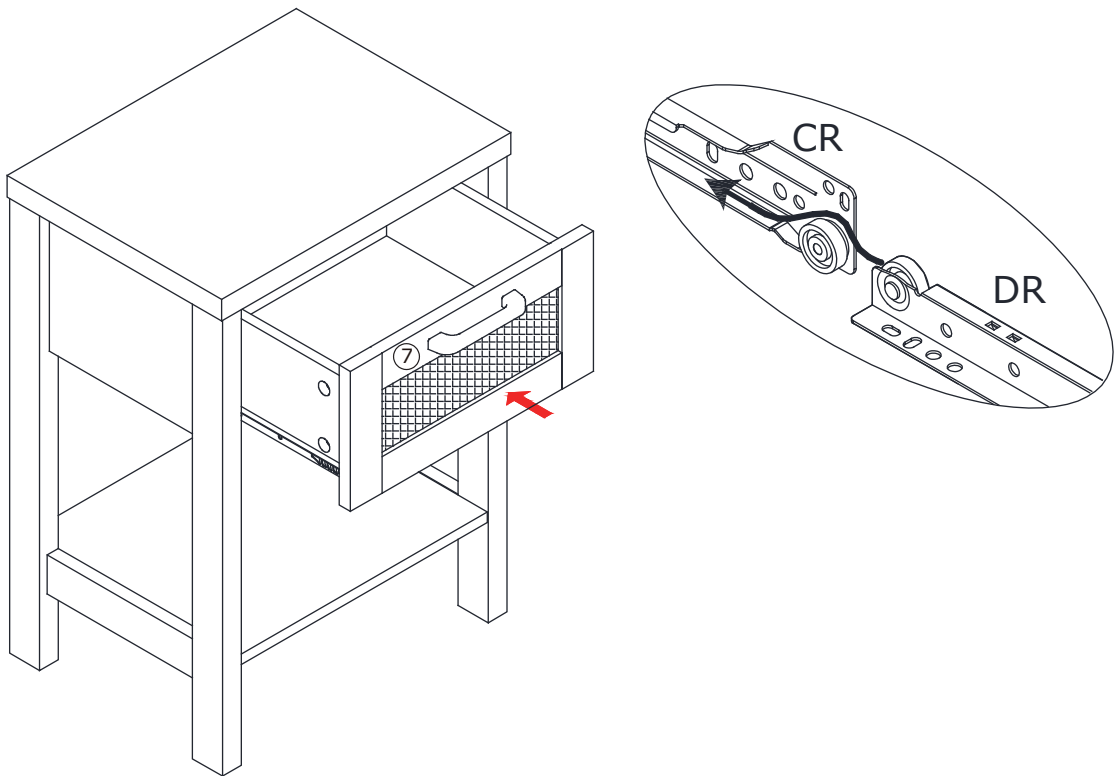

## Step 10

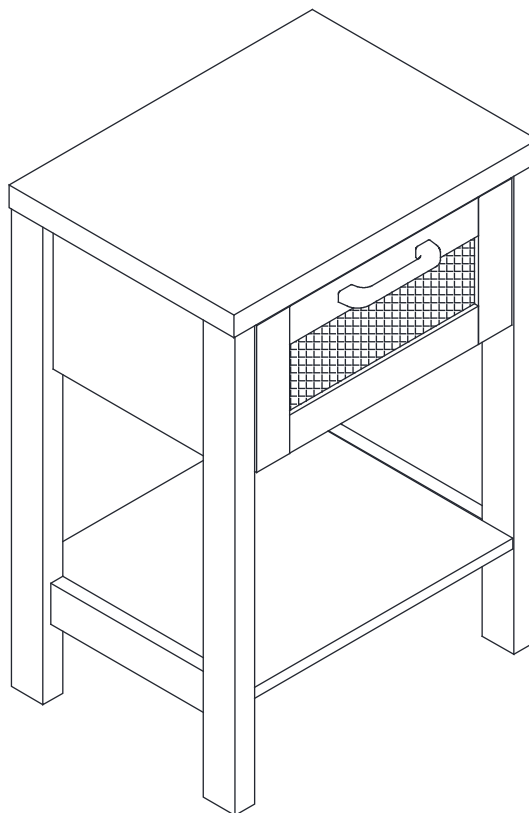

**Job complete!**