







# ASSEMBLY INSTRUCTIONS & PARTS IDENTIFICATION

## ALTAMONTE LADDER BACK CHAIR

Thank you for purchasing this quality product. Be sure to check all packing material carefully for small parts that may have come loose inside the carton during shipment.

Parts key			Hardware kit			
No	Qty	Description	No	Description	Qty	
1	1 pc	Chair Back	A	 Hex nut	M8	4 pcs
2	1 pc	Complete Seat	B	 Lock washer	Ø8	11 pcs
3	2 pcs	Front Leg	C	 Flat washer	Ø8	11 pcs
4	4 pcs	Floor Glide	D	 Long bolt	M6 x 80	4 pcs
			E	 Short bolt	M6 x 40	3 pcs
			F	 Allen key	K4	1 pc
			G	 Key wrench	13	1 pc

- Fabric Content : 73%POLYESTER / 27%COTTON
- Cleaning Code W : Clean only with water-based shampoo or foam upholstery cleaner.  
Do not over wet. Do not use solvents to spot clean.

### STEP 1

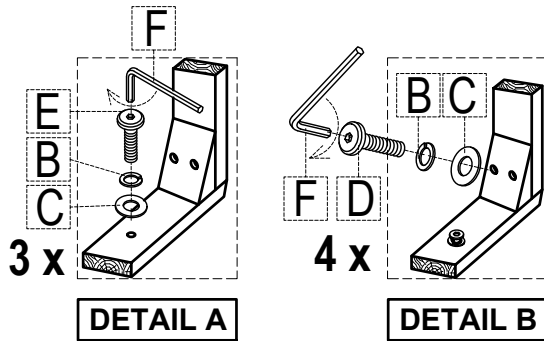

- Carefully lay Chair Back flat on a smooth flat surface to prevent scratches.
- Attach Complete Seat to Chair Back by inserting a Flat Washer (C), Lock Washer (B) and Short Bolt (E) into each of the hole on the back of the seat. Tighten screws with provided Allen Key (F) by turning clockwise until secure. (See Detail A)
- Insert a Flat Washer (C), Lock Washer (B) and Long Bolt (D) into each of 2 holes in the Complete Seat corners. Tighten screws with provided Allen Key. (See Detail B)

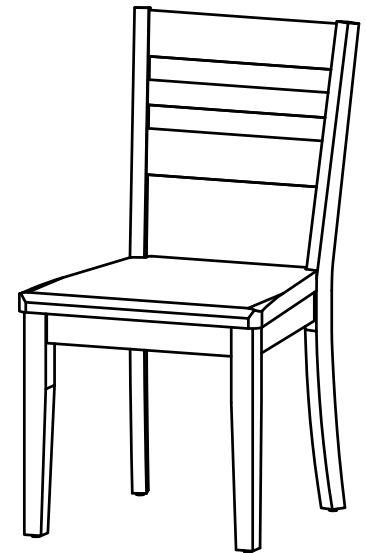
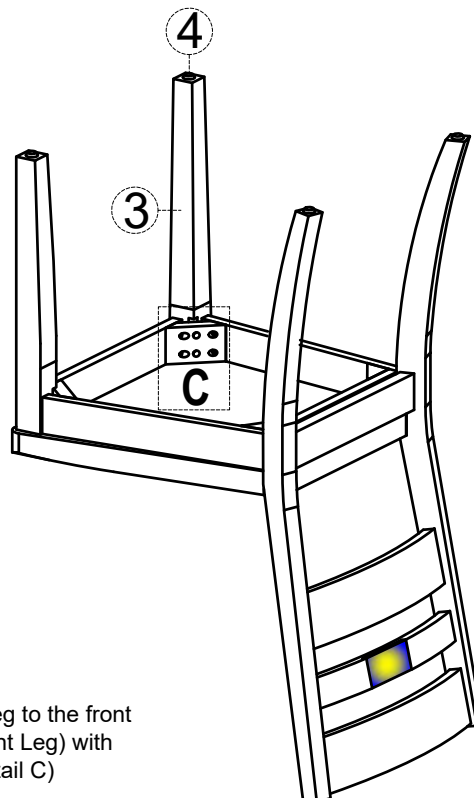
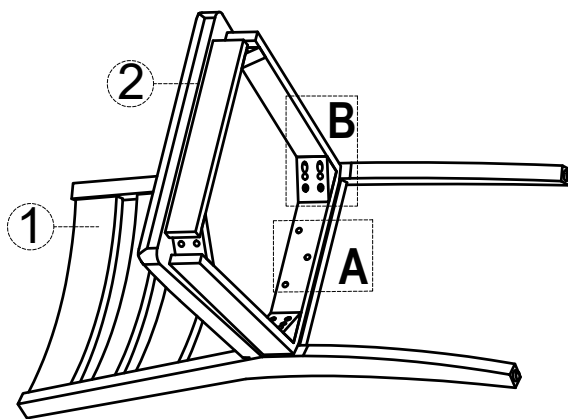

### STEP 2

- Carefully turn chair upside down and attach each Front Leg to the front corners of the Complete Seat (Keeping in mind of the Front Leg) with a Flat Washer (C), Lock Washer (B) and Nut (A). (See detail C) Keep nut loose at this point.
- Be sure to level the chair prior to tightening front leg nuts with wrench provided (G).

