

Z-BEDROOM LOFT STUDY BUNK BED

LIT SUPERPOSABLE EN Z AVEC POSTE DE TRAVAIL

LITERA EN Z CON ESCRITORIO

This bed is designed to use only a mattress which is 75-1/2" - 76-1/2" long and 53-1/2" - 54-1/2" wide. ensure thickness of mattress does not exceed 8" and mattress is at least 5" below upper edge of guardrail.

Replacement parts, including additional guardrails, may be obtained from **this Company**.

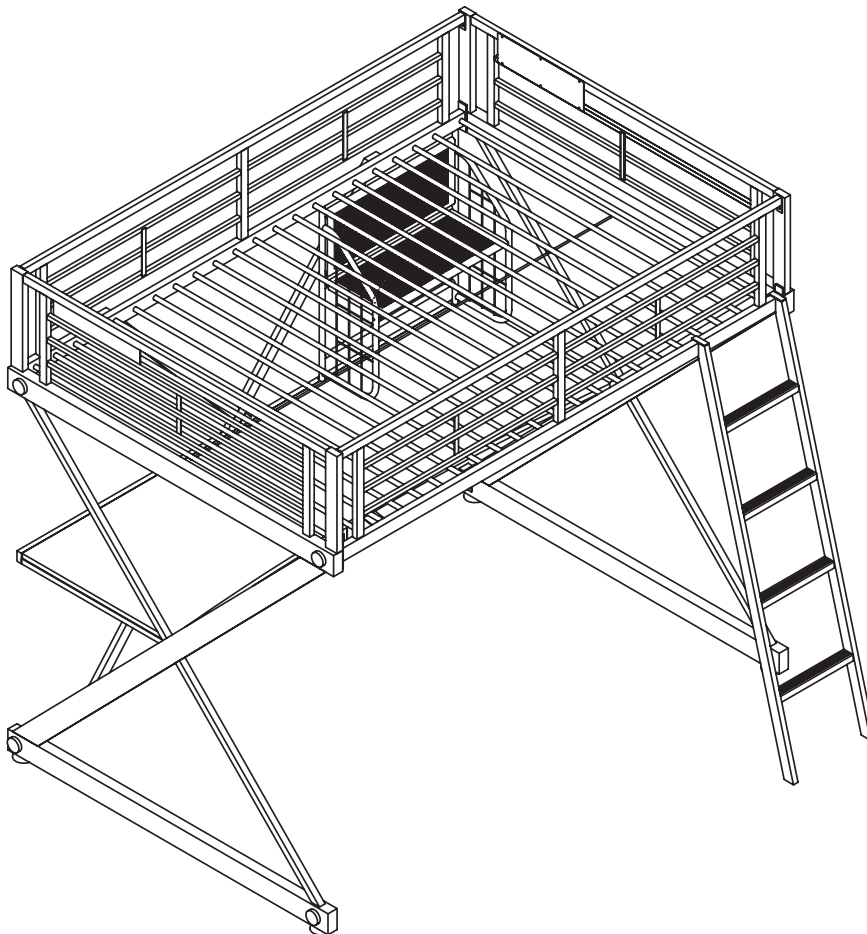

We are here to help!
Before you return it - contact us.

We do our best to insure that your furniture arrives in excellent condition.

Nous sommes là pour vous aider!
Avant de retourner le produit, veuillez communiquer avec nous.

Nous faisons tout en notre pouvoir pour que vous receviez votre meuble en parfait état.

¡Estamos aquí para ayudarle!
Antes de regresar el producto, comuníquese con nosotros.

Hacemos todo lo posible para que su mobiliario se le entregue en excelentes condiciones.





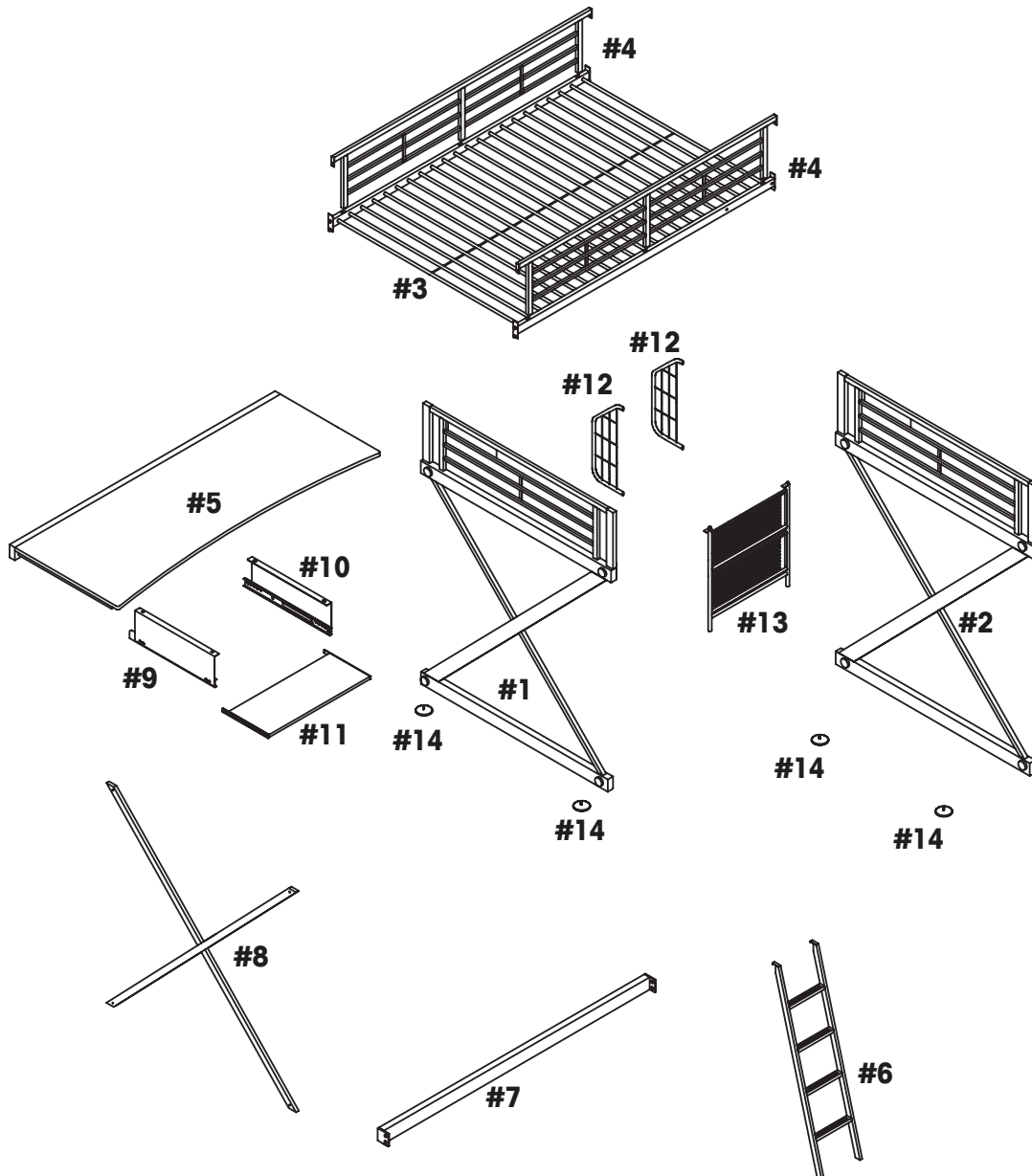

PART LIST

#1	LEFT PANEL	01
#2	RIGHT PANEL	01
#3	BED FRAME	01
#4	GUARDRAIL	02
#5	DESK TOP	01
#6	LADDER	01
#7	HORIZONTAL CROSS BRACE	01

#8	"X" CROSS BRACE	01
#9	LEFT SIDE KEYBOARD	01
#10	RIGHT SIDE KEYBOARD	01
#11	KEYBOARD	01
#12	BOOKCASE SIDE PANEL	02
#13	BOOKCASE BACK PANEL	01
#14	ADJUSTABLE LEG	04



HARDWARE LIST

A	BOLT (Ø1/4"X2-1/4")		02
B	BOLT (Ø5/16"X1-1/2")		02
C	BOLT (Ø1/4"X1-1/2")		08
D	BOLT (Ø1/4"X5/8")		08
E	BOLT (Ø1/4"X1/2")		04
F	BOLT (Ø1/4"X1-1/2")		06

TOOLS REQUIRED

ALLEN KEY		SUPPLIED
------------------	---	-----------------

IMPORTANT:

1. Do not tighten bolts completely until all bolts are completely lined up and inserted into holes / nuts.
2. Do not over tighten screws and bolts to avoid stripping.
3. Please use hand tools to assemble this product. Do not use power tools.

1.

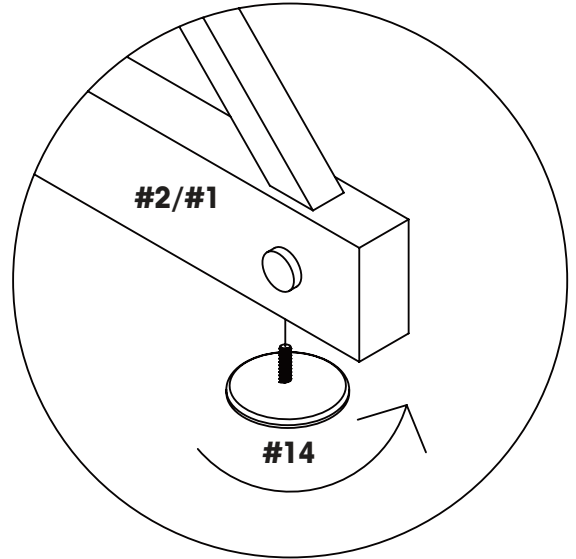
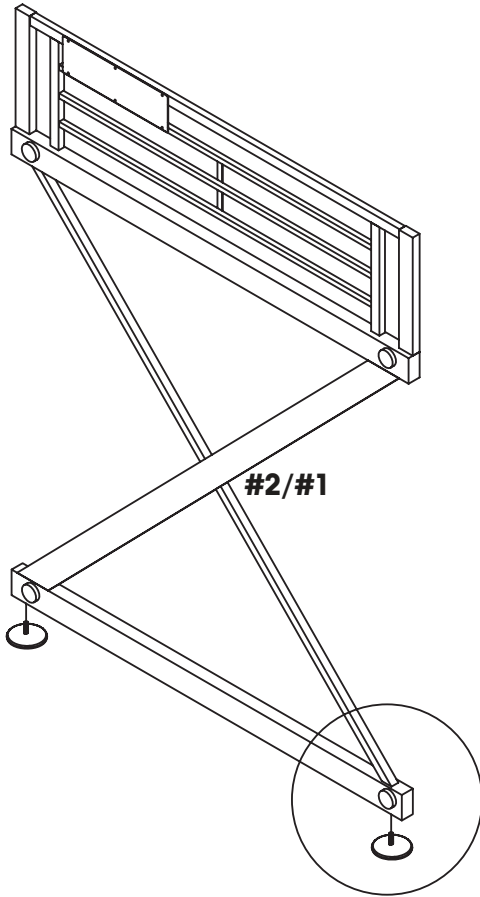

2.

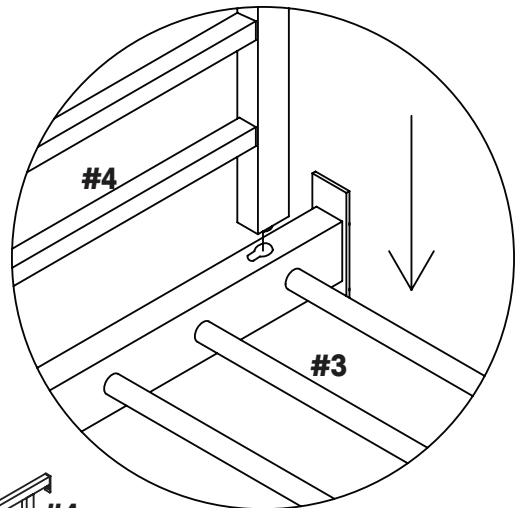
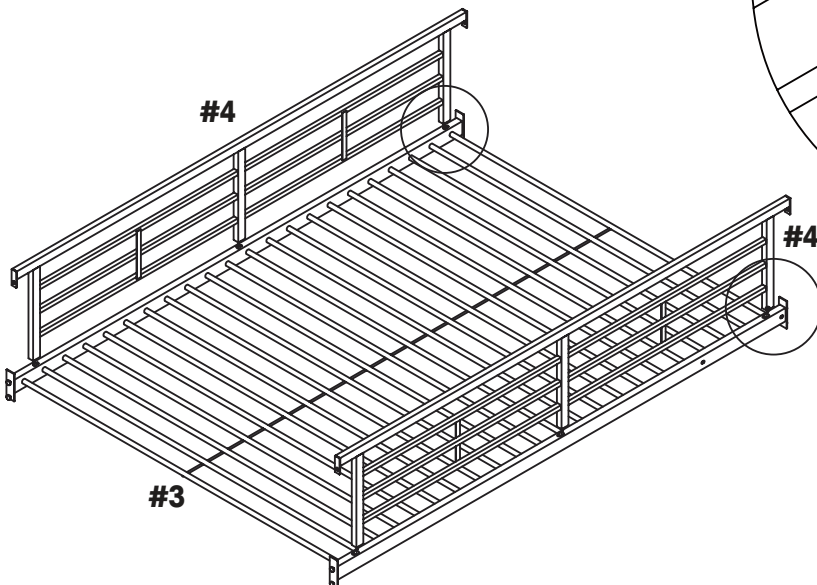

3.

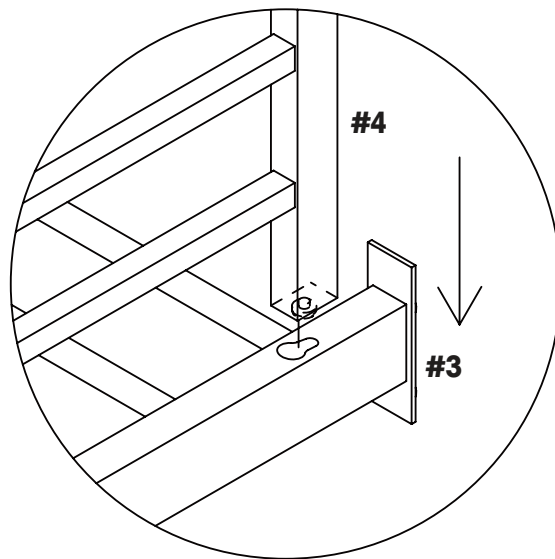
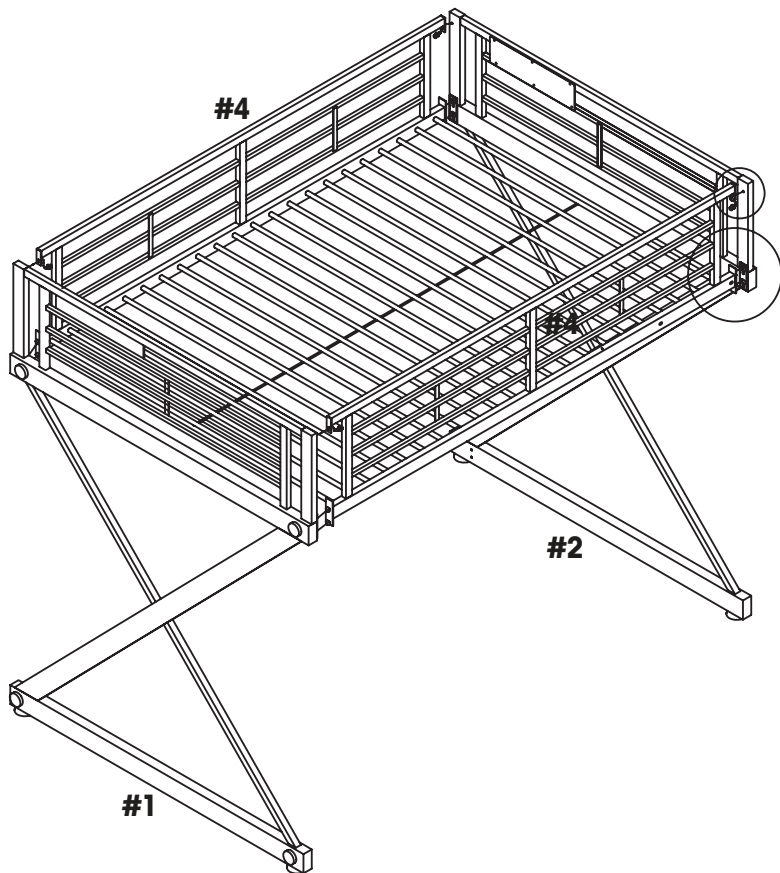
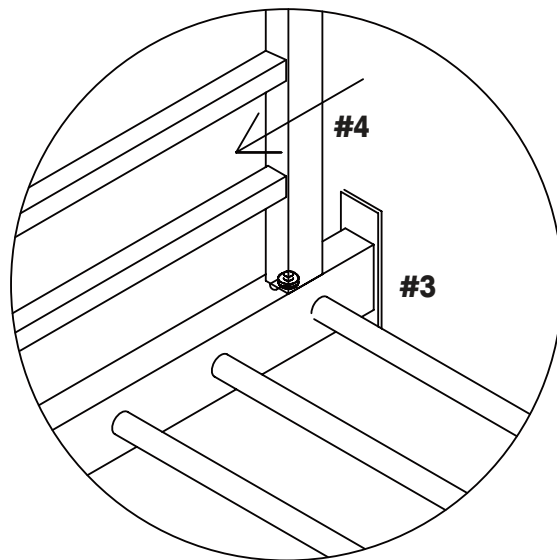
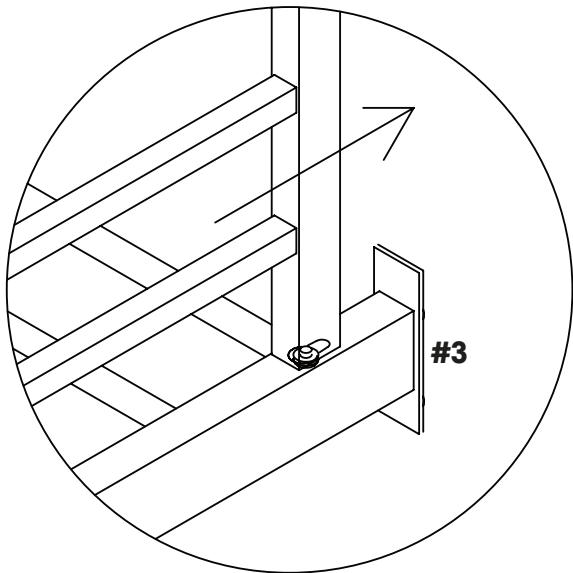

4.

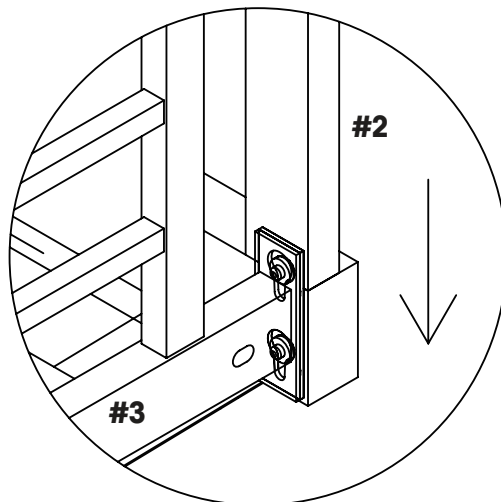
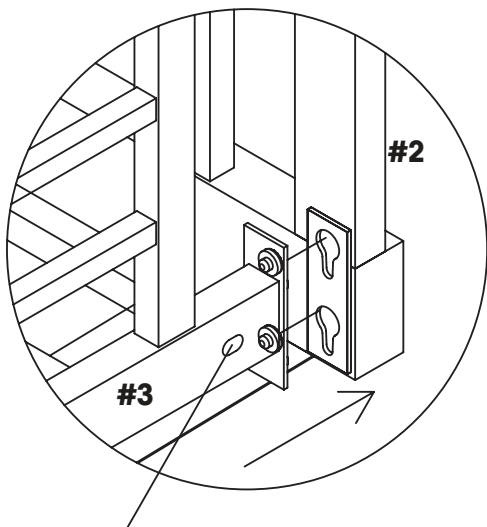

Bed edge with ladder holes always faces front.

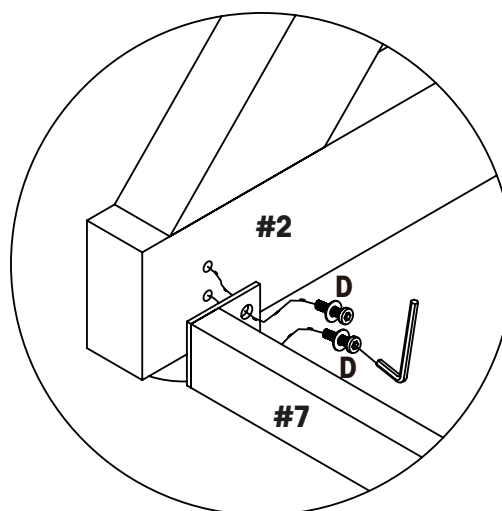
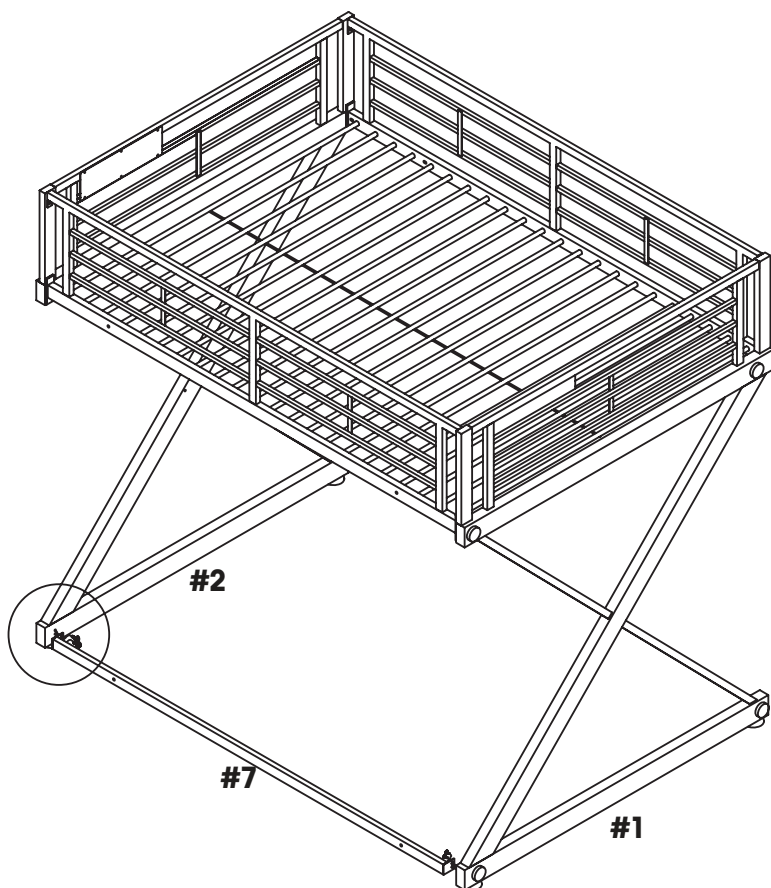
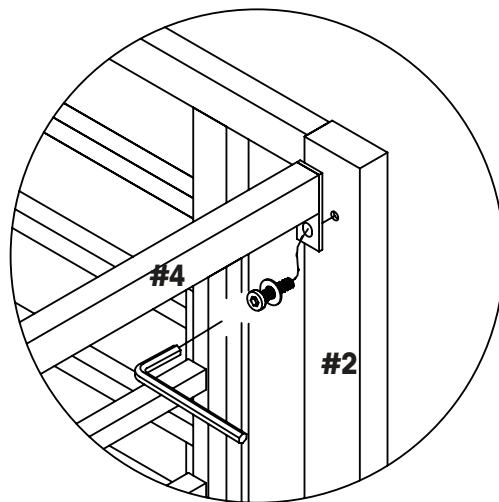

D		04
---	--	----

5.

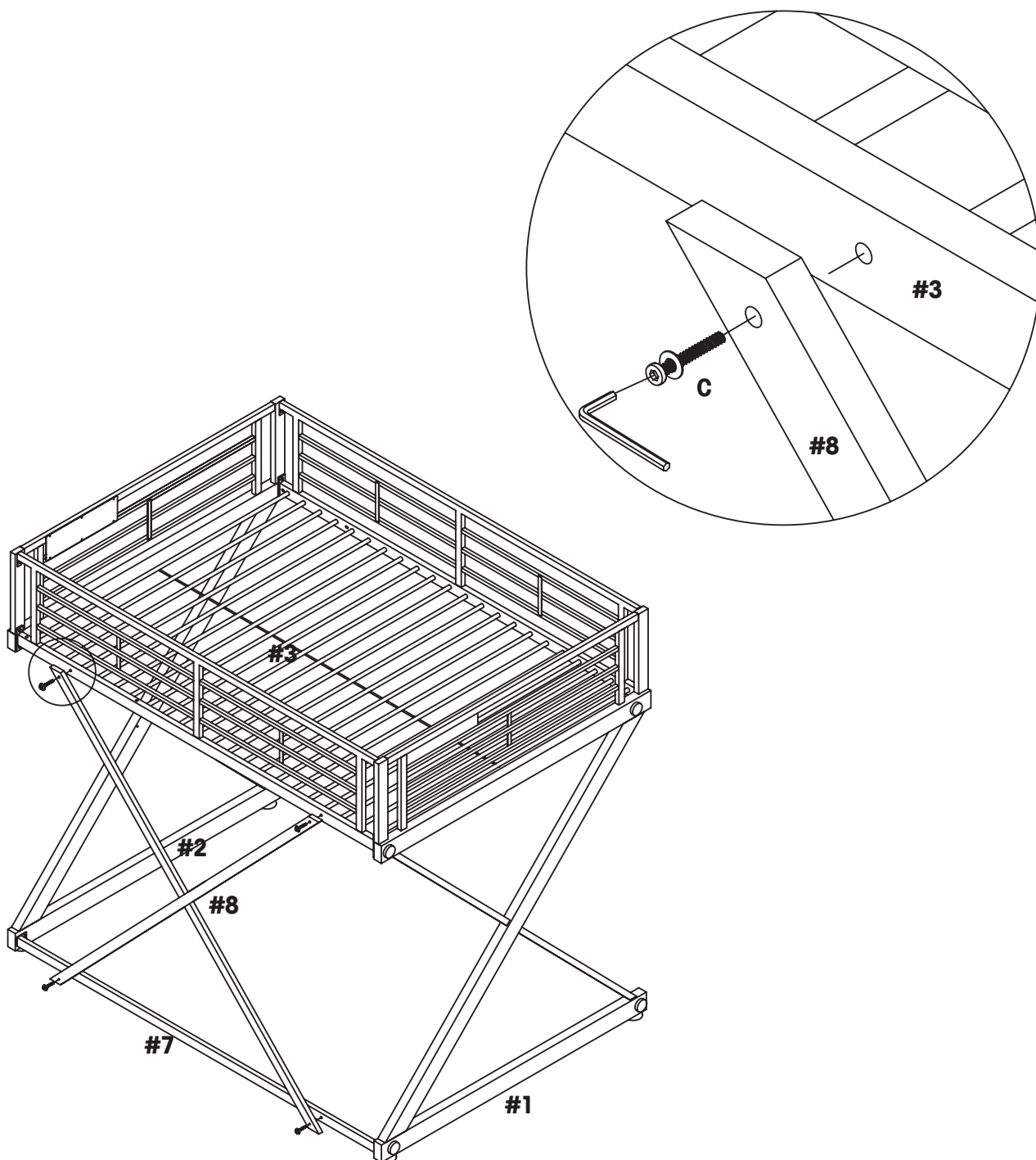

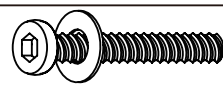
C		04
---	---	----

6.

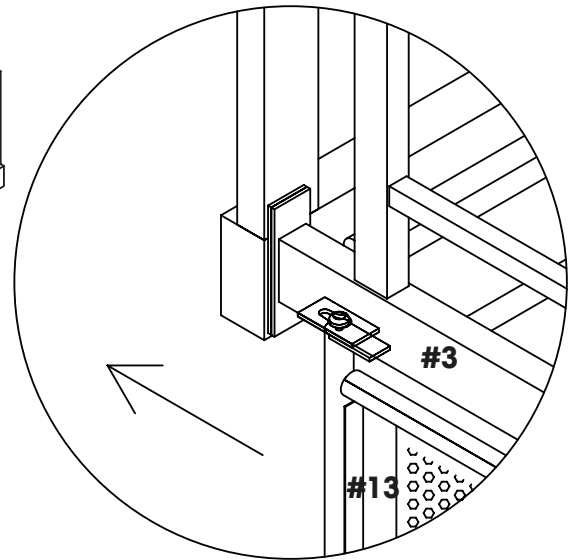
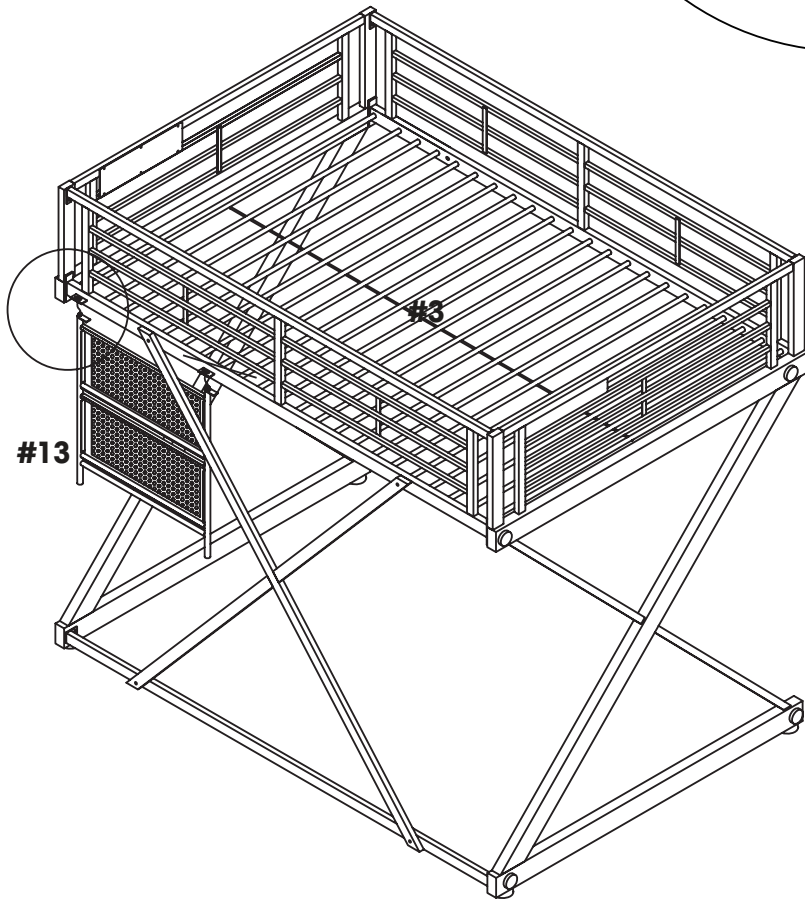
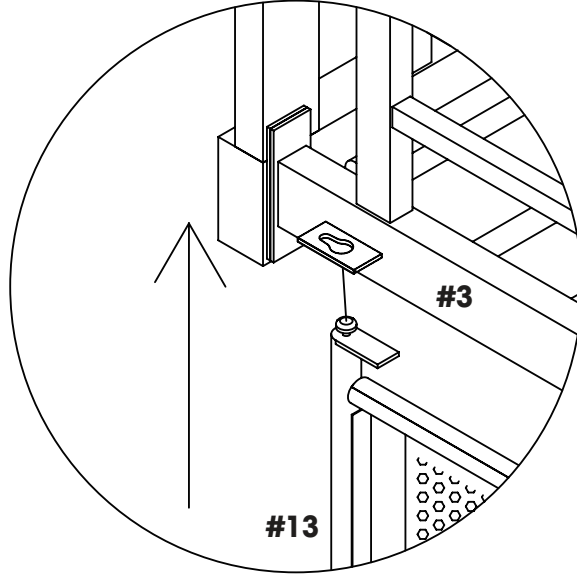

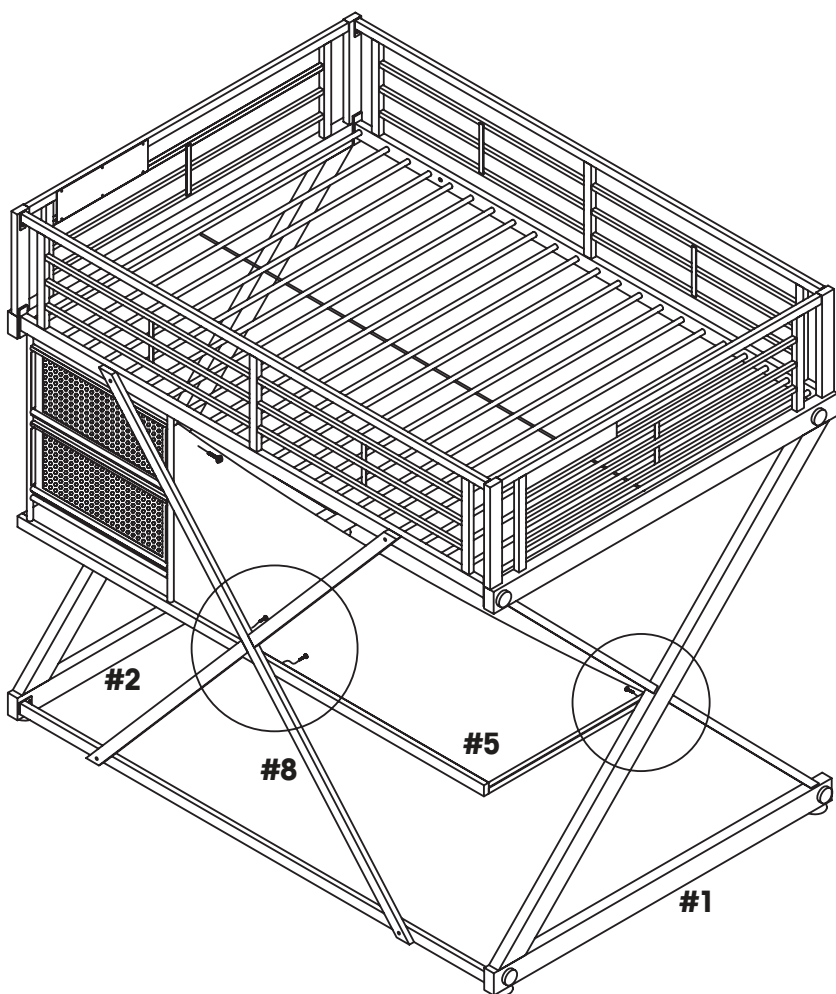
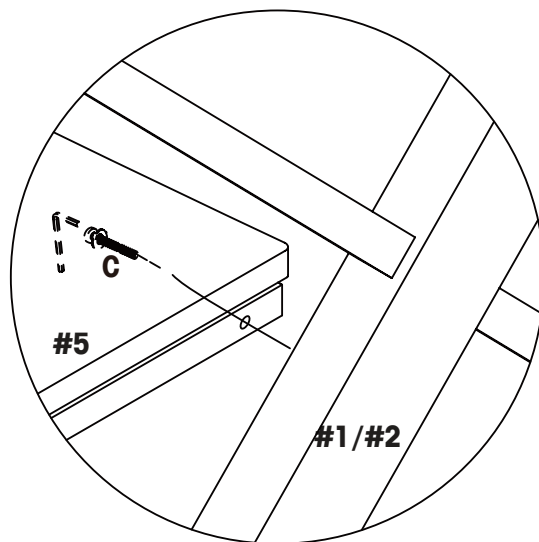
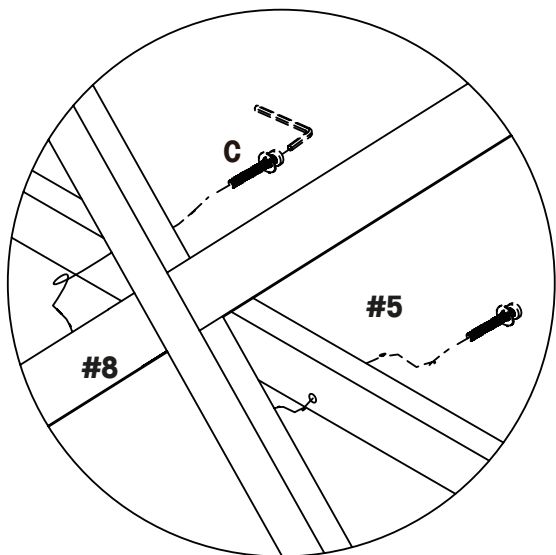

7.

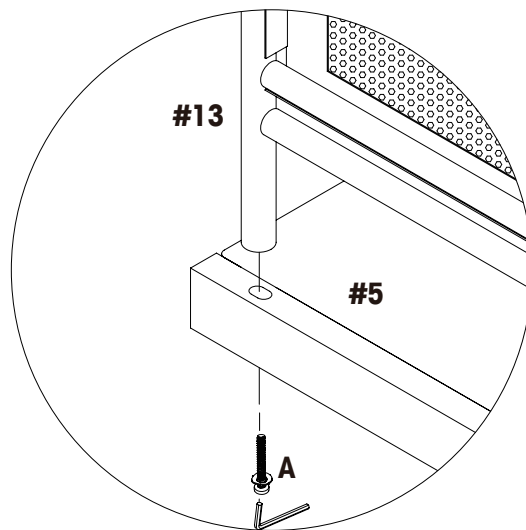
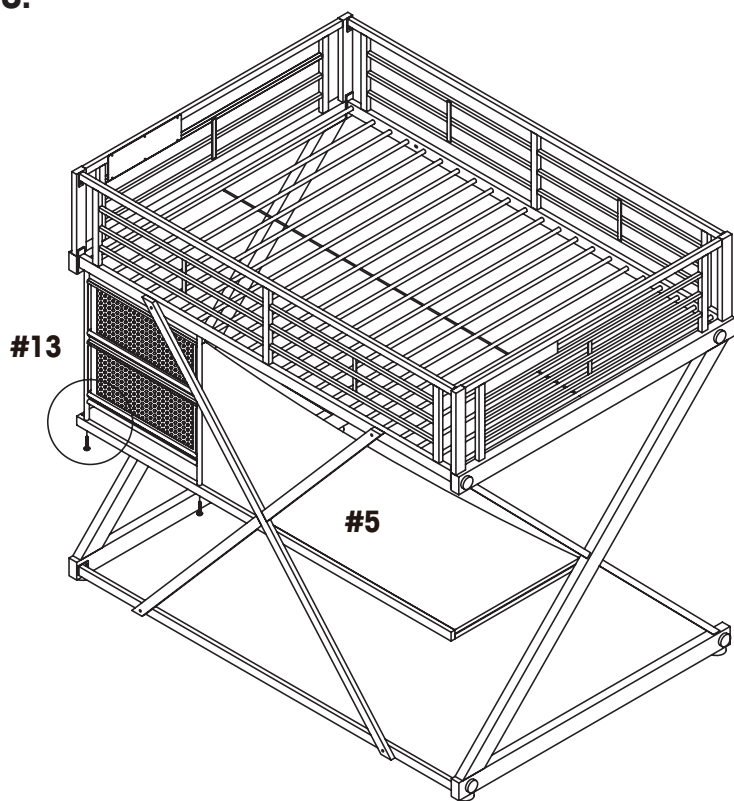

C		04
---	--	----

8.



A		02
---	---	----

9.

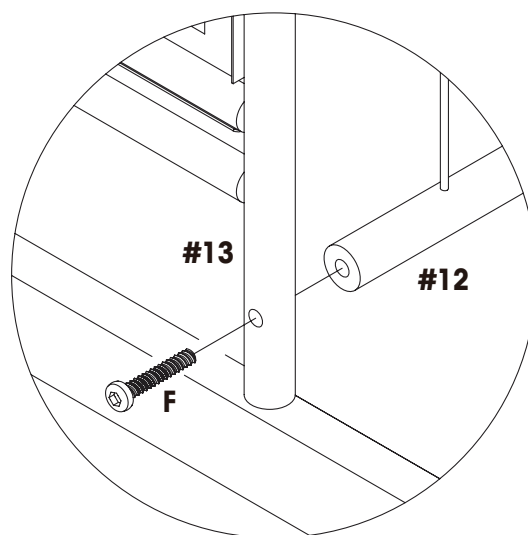
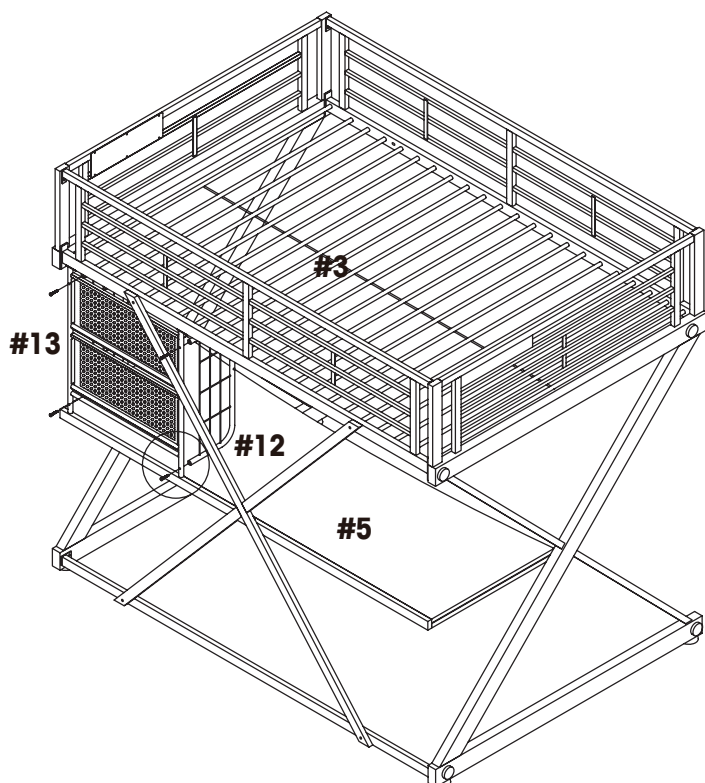

F		04
---	---	----

10.

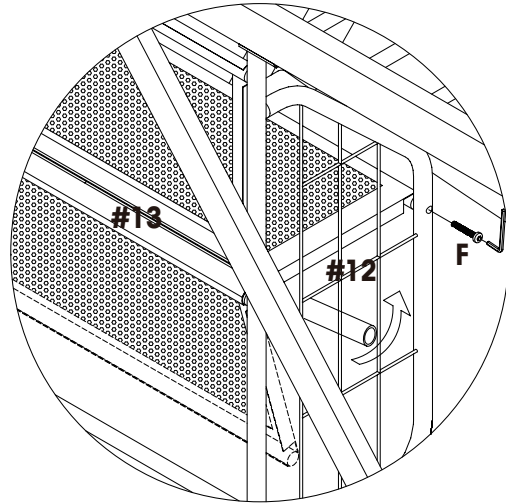
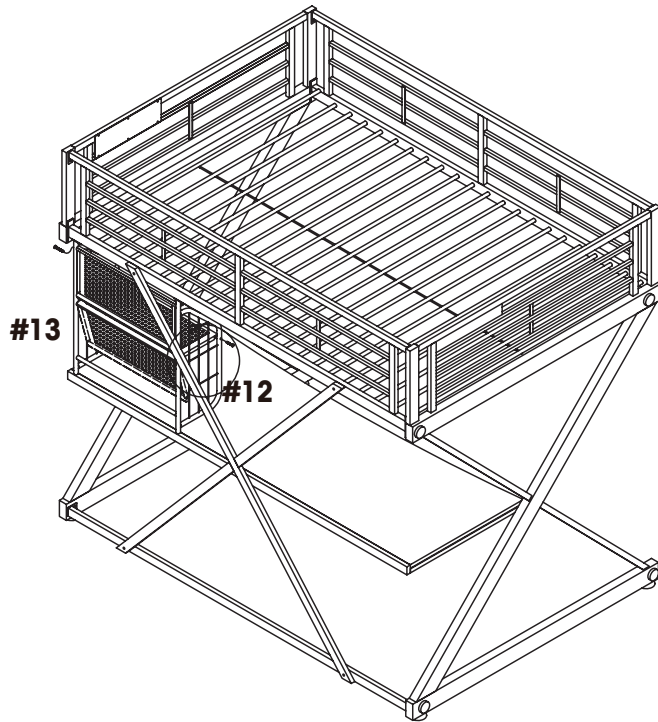

F



02

11.

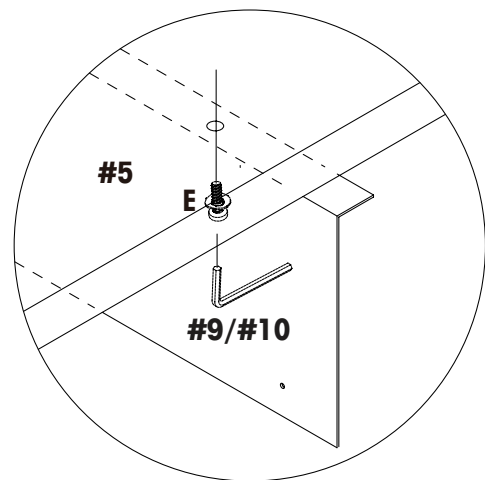
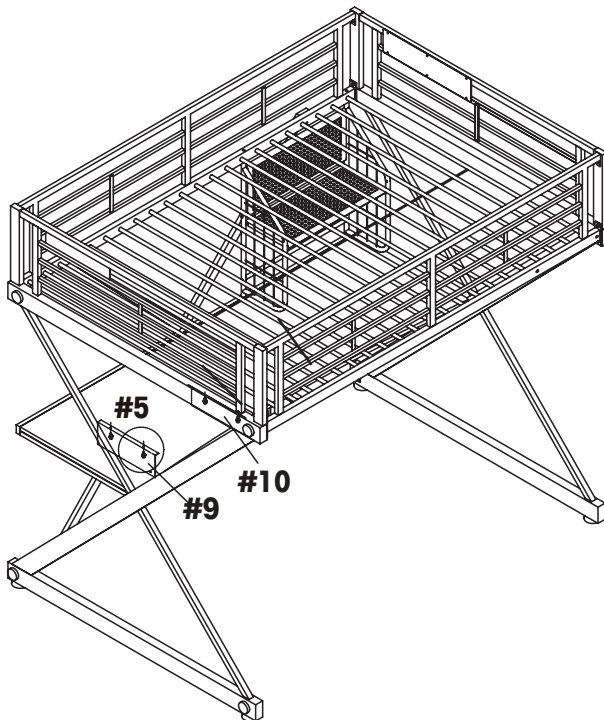

E



04

12.

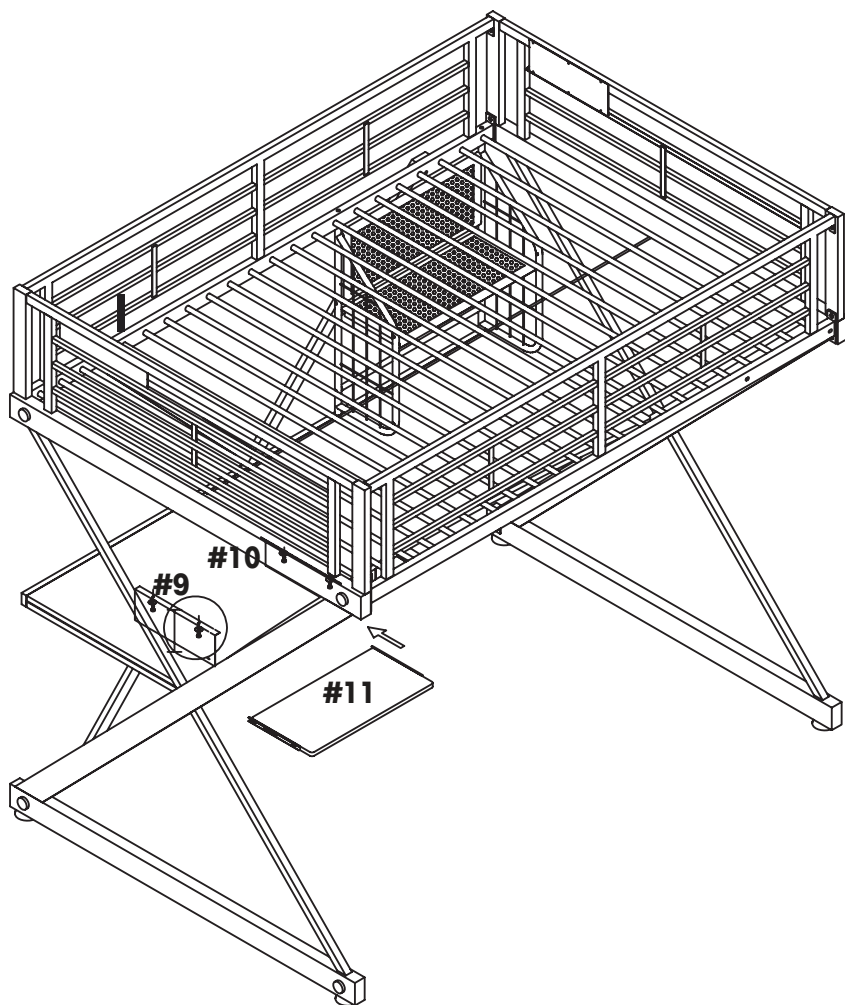
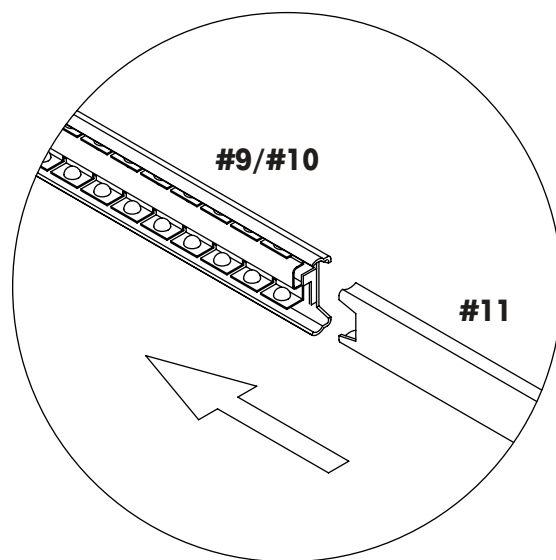
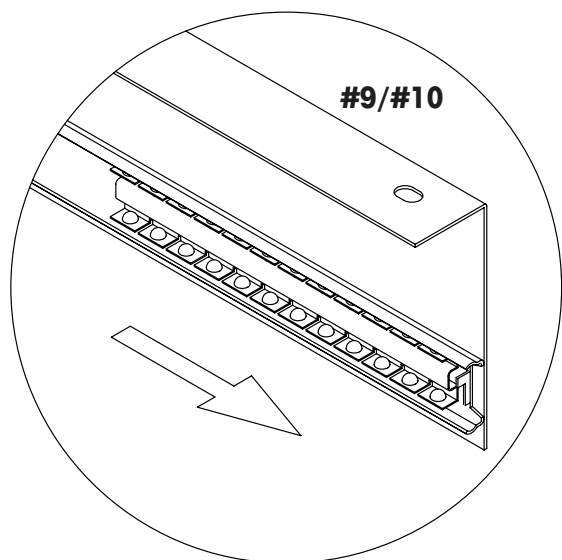

13.

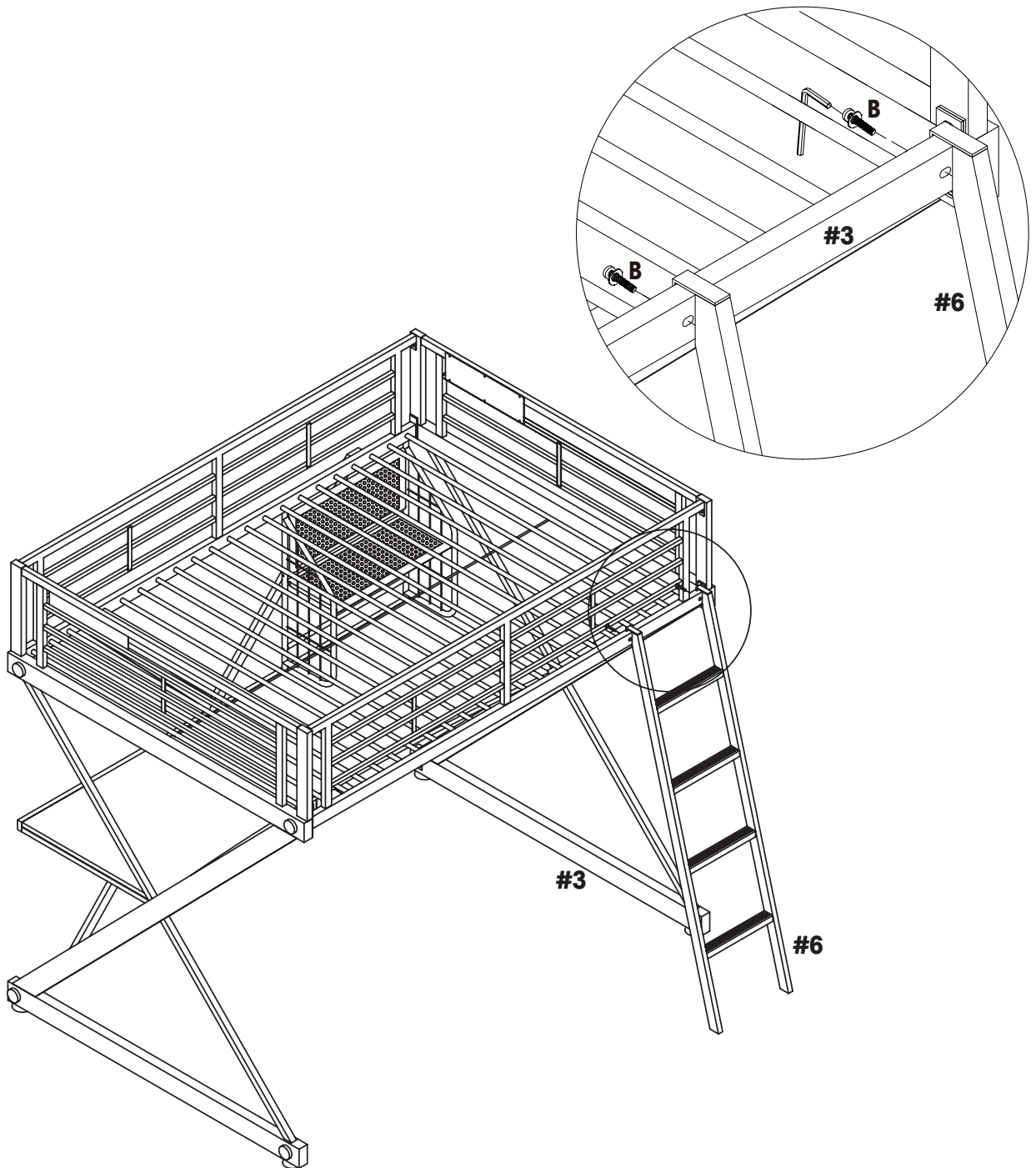

FOLLOW THE INFORMATION ON THE WARNING APPEARING ON THE UPPER BUNK END STRUCTURE AND ON THE CARTON. DO NOT REMOVE WARNING LABEL FROM BED. KEEP THESE INSTRUCTION FOR FUTURE REFERENCE.

B		02
---	---	----



WARNING TO HELP PREVENT SERIOUS OR FATAL INJURIES FROM ENTRAPMENT OR FALLS:

- Never allow a child under 6 years old on the upper bunk.
- Always use the recommended size mattress or mattress support, or both, to help prevent the likelihood of entrapment or falls.
- Use only a mattress which is 75-1/2" - 76-1/2" long and 53-1/2" ~ 54-1/2" wide on the upper bunk.
- Ensure thickness of mattress does not exceed 6" and surface of mattress is at least 5" below upper edge of guardrails.
- Always use guardrails on both long sides of the upper bunk.
- If bunk bed will be placed next to a wall, the guardrail that runs the full length of the bed should be placed against the wall to prevent entrapment between the bed and the wall.
- Prohibit horseplay on or under bed(s) and prohibit jumping on the bed.
- Prohibit more than one person on upper bunk.
- Use ladder for entering and leaving upper bunk.
- Maximum total weight is not to exceed 300 lbs. on the upper bunk.
- Periodically check and ensure that the guardrail, ladder, and other components are in their proper position, free from damage, and that all connectors are tight.
- Do not use substitute parts. Replacement parts, including additional guardrails, may be obtained from our customer service department.
- Use of water or sleep flotation mattresses is prohibited.
- Use of a night light may provide added safety precaution for a child using the upper bunk.
- Follow the information on the warnings appearing on the upper bunk end structure and on the carton.
- Keep these instructions for future reference.

STRANGULATION HAZARD Never attach or hang items to any part of the bunk bed that are not designed for use with the bed; for example, but not limited to, hooks, belts and jump ropes.

DO NOT REMOVE THIS LABEL, KEEP THESE INSTRUCTIONS FOR FUTURE REFERENCE.

LIMITED WARRANTY

GARANTIE LIMITÉE

GARANTÍA LIMITADA

MADE IN CHINA
FABRIQUÉ EN CHINE
HECHO EN CHINA

