

# ASSEMBLY INSTRUCTIONS

## ITEM # 7631 / 7632 / 7633

### FULL / QUEEN Metal Platform Bed

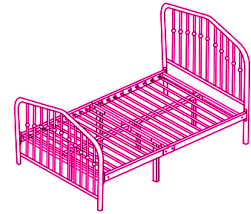

#### ASSEMBLY TIPS:

1. Remove hardware from box and sort by size.
2. Please check to see that all hardware and parts are **complete before start assembling**.
3. Please follow instructions in the same **order sequence numbers** to assure fast & easy assembly.

#### WARNING!





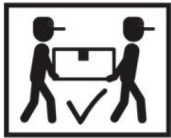





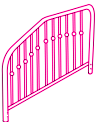

1. Don't attempt to repair or modify parts that are broken or defective. Please contact the store immediately.
2. This product is for home use only and not intended for commercial establishments.
3. **THE LIST AND QUANTITY SHOWN ARE FOR 1 UNIT ASSEMBLY.**

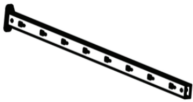
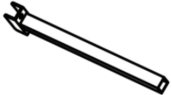
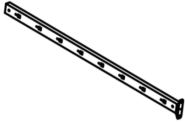

ASSEMBLY TIME

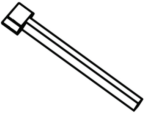
60 MINUTES

### PARTS LIST

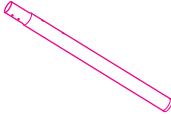
<b>A. HEADBOARD</b>		1PC	<b>H. FRONT CENTER RAIL</b>		1PC
<b>B. FOOTBOARD</b>		1PC	<b>I. REAR CENTER RAIL</b>		1PC
<b>C. SIDE RAIL 1</b>		2PCS	<b>J. FRONT / REAR CENTER RAIL SUPPORT LEG</b>		3PCS
<b>D. SIDE RAIL 2</b>		2PCS	<b>K. SLAT</b>		16PCS
<b>E. CENTER RAIL SUPPORT LEG</b>		2PCS	<b>L. SLAT CONNECTOR</b>		32PCS
<b>F. HEADBOARD / FOOTBOARD SUPPORT BAR</b>		2PCS	<b>M. RAIL U-BRACKET</b>		2PCS
<b>G. CENTER RAIL SUPPORT BAR</b>		1PC	<b>N. HEADBOARD LEG</b>		2PCS

### HARDWARE LIST

<b>1. BOLT (Ø 1/4"x16MM)</b>		30PCS	<b>4. ALLEN WRENCH (1/4")</b>		1PC
<b>2. BOLT (Ø 1/4"x35MM)</b>		10PCS	<b>5. OPEN WRENCH (1/4")</b>		1PC
<b>3. NUT (Ø 1/4")</b>		6PCS			

#### CAUTIONS:



1. **DO NOT FULLY** - Tighten the bolts until the bed is assembled completely.
2. Keep all hardware parts out of reach of children.

ITEM # 7631 / 7632 / 7633  
**FULL / QUEEN Metal Platform Bed**

**⚠ ATTENTION**



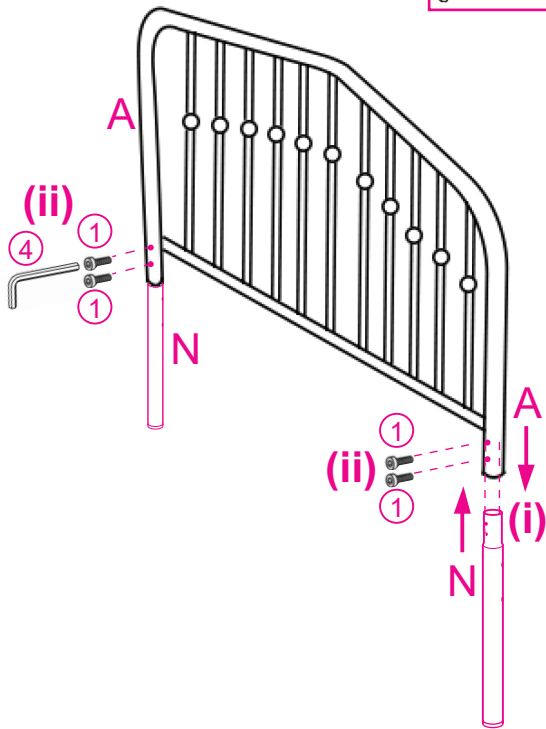

**DO NOT FULLY** tighten all bolts until the bed is assembled completely.

**STEP 1**

-  1 x 4
-  4 x 1



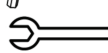

**STEP 2**

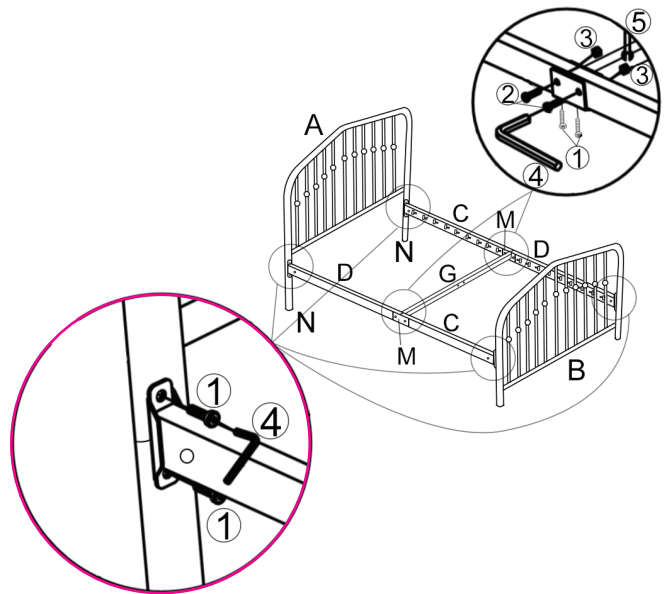
-  1 x 12
-  2 x 4
-  3 x 4
-  4 x 1
-  5 x 1





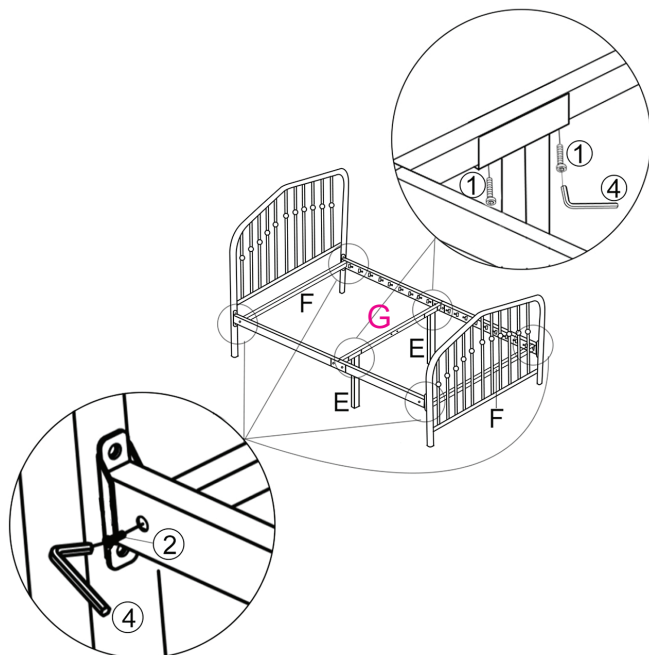

**STEP 3**

-  1 x 4
-  2 x 4
-  4 x 1

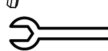

**STEP 4**

-  1 x 2
-  2 x 2
-  3 x 2
-  4 x 1
-  5 x 1

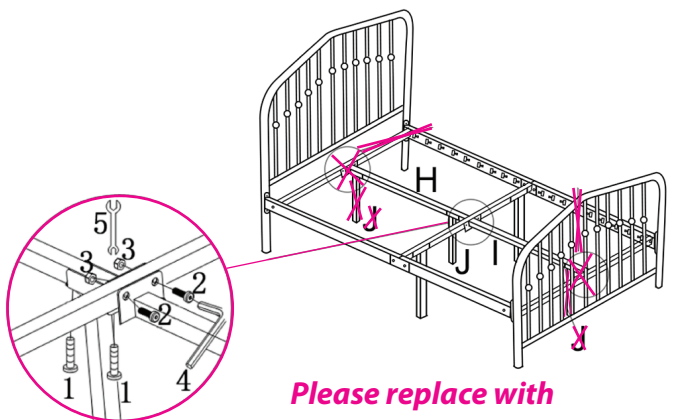

**Please replace with correct drawing!  
 Remove "J"  
 from Front Center Rail  
 and Rear Center Rail**

ITEM # 7631 / 7632 / 7633  
FULL / QUEEN Metal Platform Bed

**⚠ ATTENTION**

For parts use on wooden floor, hard surface or carpet, it is recommended to install protective pads under all legs and supports to avoid/prevent from damages/scratches and discoloration on the floor.

**STEP 5**

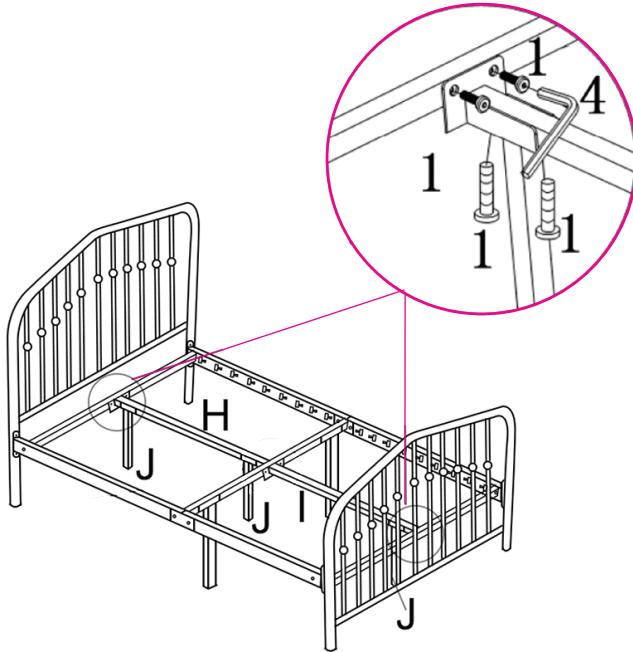
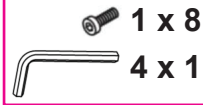

**STEP 6**

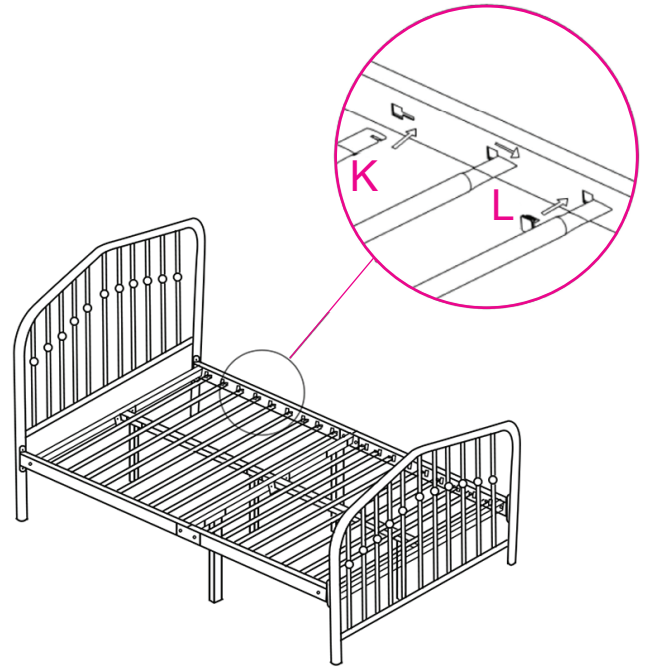

**ASSEMBLY COMPLETED**

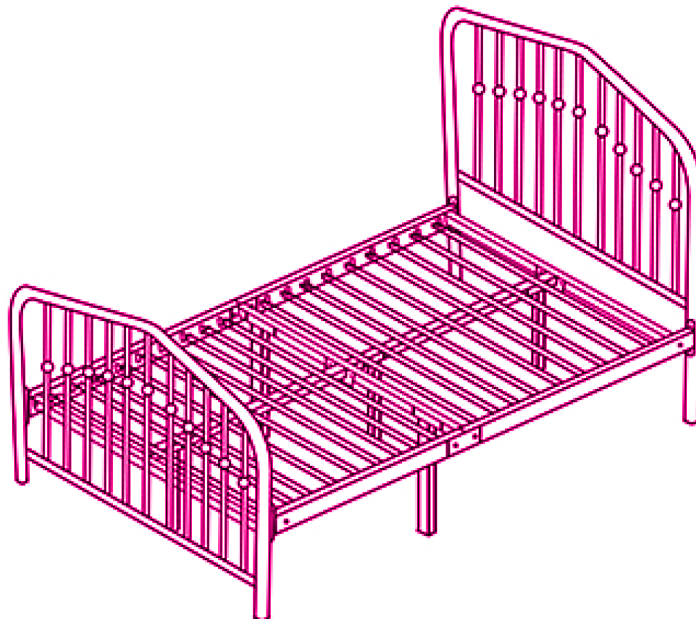

Your Platform Bed is now ready!  
Make sure all bolts are fully tightened before using.  
**DO NOT** Jump or Stand on top.

