

ASSEMBLY INSTRUCTIONS FOR ACME FURNITURE

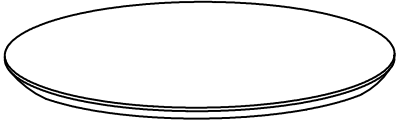
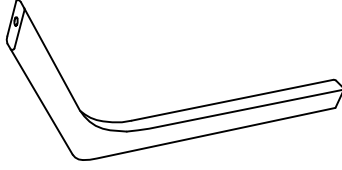
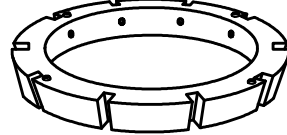

MODEL#DN04190-1/DN04190-2

Thank you for purchasing the quality product. Be sure to check all packing material carefully for small parts which may have come loose inside the carton during shipment. Separate, identify and count all parts and metal hardware. Compare with all parts list to be sure all parts are present. If any part(s) are missing or damaged, please contact your local furniture dealer. For efficient and speedy service, please indicate the model number and code letter of part(s) needed.

*** Do not fully tighten screws until fully assembled ***

COMPONENT PARTS		
DESCRIPTION	PART NAME	Q'TY(PCS)
①	TABLE TOP 	1
②	TABLE LEG 	10
②	BASE FRAME 	1

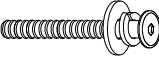
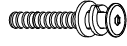
HARDWARE REQUIRED

- A

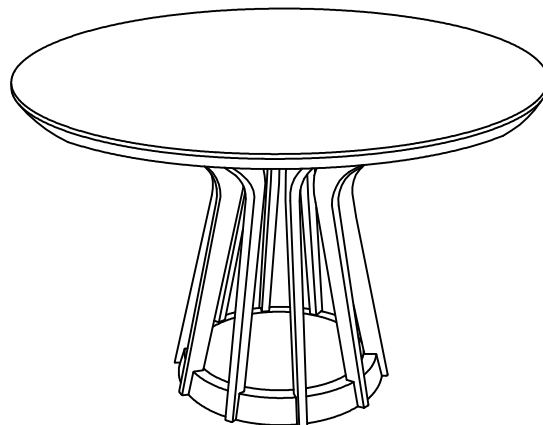
 JCBB M8 x 60mm + S/W 5/16" + F/W 5/16"x 22mm
 10 PCS
- B

 JCBC M6 x 40mm + S/W M6 + F/W M6 x 13mm
 10 PCS
- C

 ALLEN KEY M5
 1 PC
- D

 ALLEN KEY M4
 1 PC



Attention

** Some number parts listed on the instruction sheet may not be in parts bag as they may already be assembled. Carefully check parts and packing materials prior to ordering replacements.

How to assemble:

STEP 1

DO NOT FULLY
TIGHTEN THE BOLT

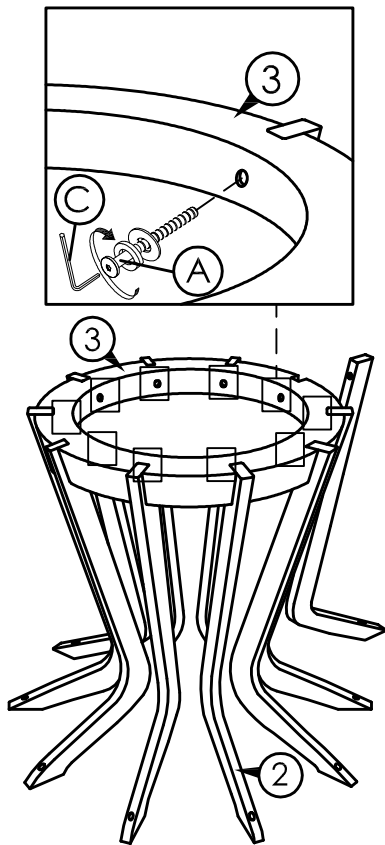

STEP 2

FULLY TIGHTEN ALL BOLTS

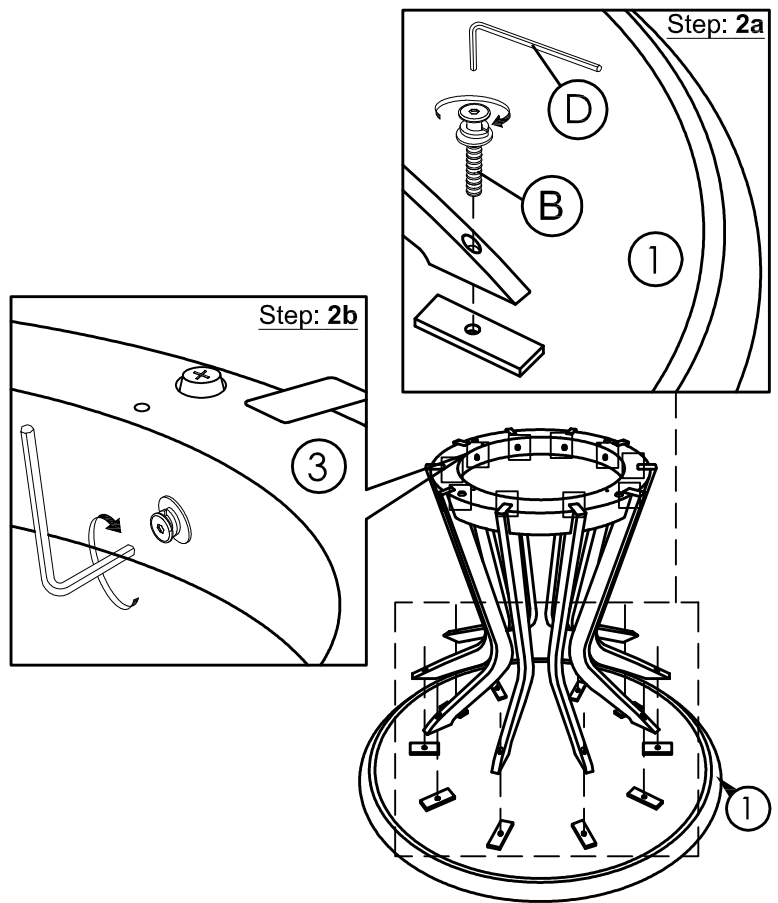

STEP 3

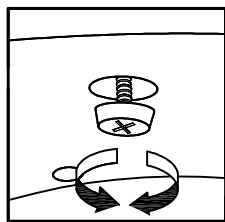
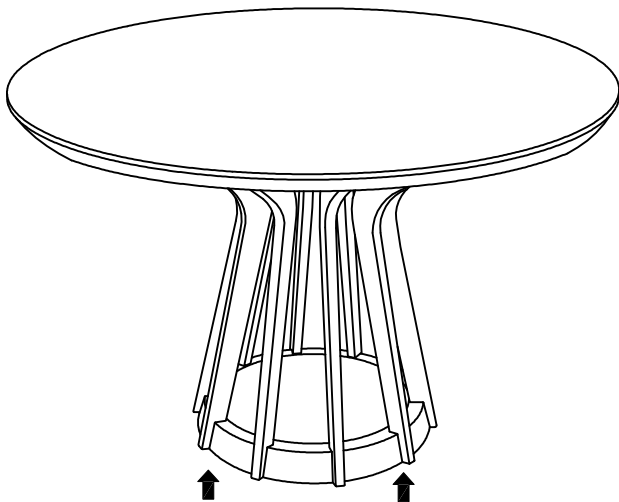

Turn clockwise or
anti-clockwise to adjust
leg leveller.

STEP 4

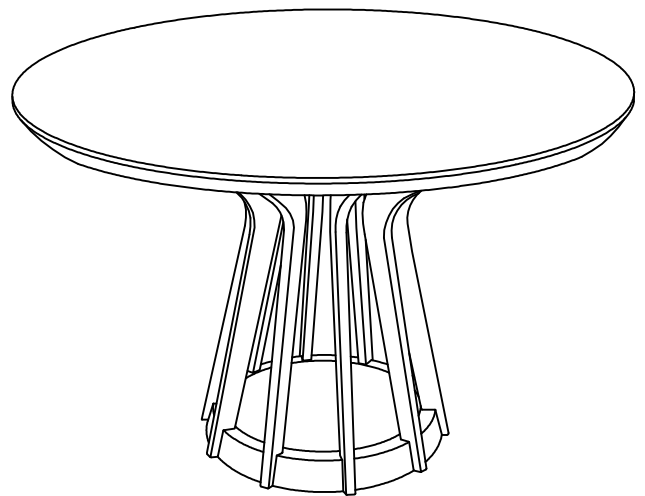

ASSEMBLY INSTRUCTIONS FOR ACME FURNITURE

MODEL#DN04191 / DN04192

Thank you for purchasing the quality product. Be sure to check all packing material carefully for small parts which may have come loose inside the carton during shipment. Separate, identify and count all parts and metal hardware. Compare with all parts list to be sure all parts are present. If any part(s) are missing or damaged, please contact your local furniture dealer. For efficient and speedy service, please indicate the model number and code letter of part(s) needed.

*** Do not fully tighten screws until fully assembled ***

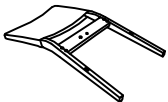
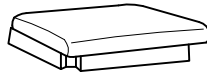
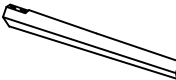
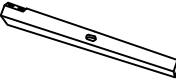
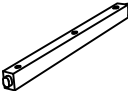
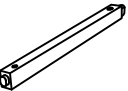
DESCRIPTION	COMPONENT PARTS	
	PART NAME	Q'TY(PCS)
①	BACK REST 	1
②	BOX SEAT 	1
③	FRONT LEG (LEFT) 	1
④	FRONT LEG (RIGHT) 	1
⑤	SIDE RAIL (LEFT) 	1
⑥	SIDE RAIL (RIGHT) 	1

HARDWARE REQUIRED

- A  JCBC M6 x 80mm + S/W M6 + F/W M6 x 19mm 4 PCS
- B  JCBC M6 x 60mm + S/W M6 + F/W M6 x 19mm 4 PCS
- C  JCBC M6 x 40mm + S/W M6 + F/W M6 x 19mm 2 PCS
- D  ALLEN KEY M4 1 PC
- E  PH CB SCREW M4 x 38mm 4 PCS
- F  DOWEL M10 x 30mm 1 PC
- G  PVC NAIL 5/8" (WITH PIN) 4 PCS

TOOLS NEEDED

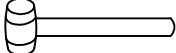
 (NOT PROVIDED)

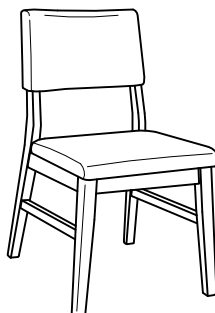

Attention

** Some number parts listed on the instruction sheet may not be in parts bag as they may already be assembled. Carefully check parts and packing materials prior to ordering replacements.

How to assemble:

STEP 1

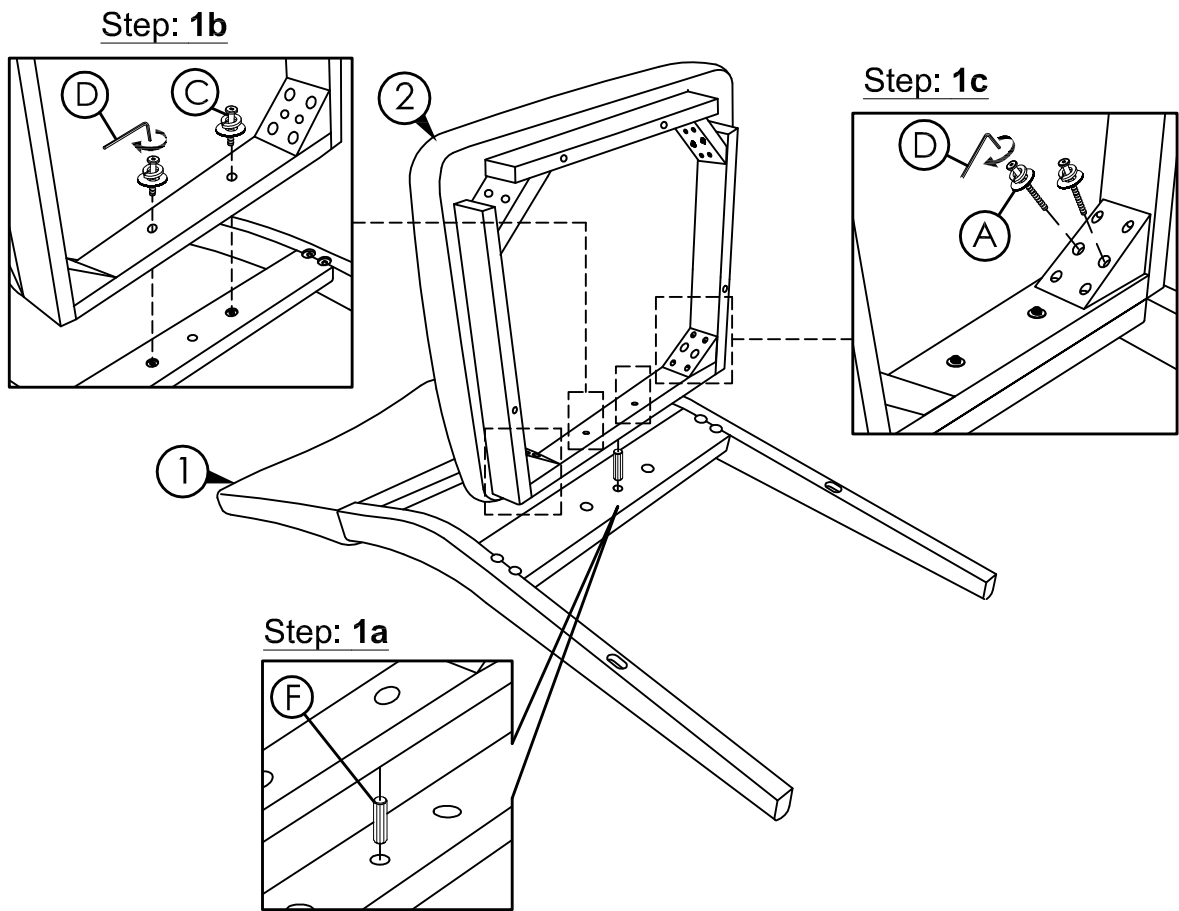

STEP 2

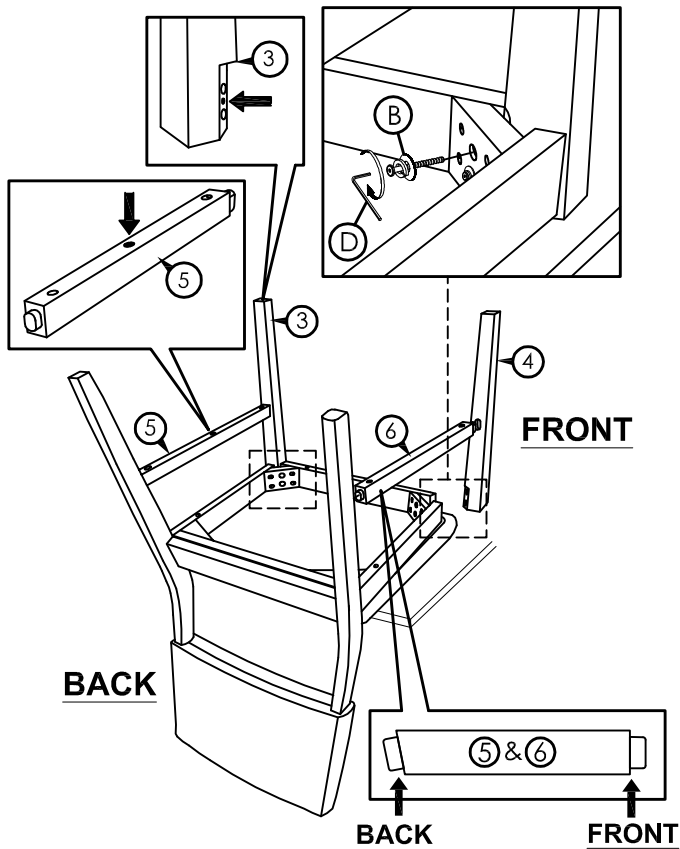

STEP 3

