

ASSEMBLY INSTRUCTIONS

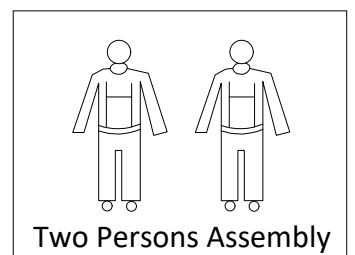

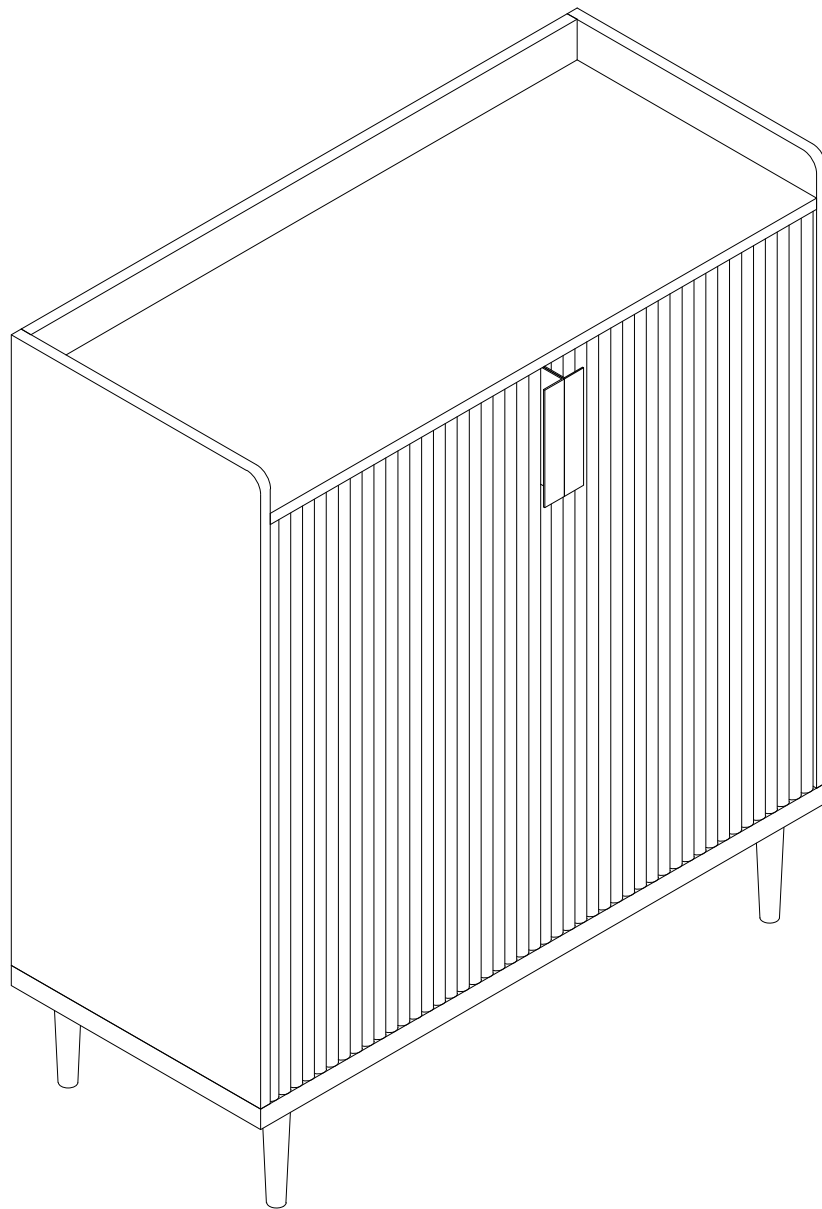

ASSEMBLY TOOLS REQUIRED (NOT INCLUDED)

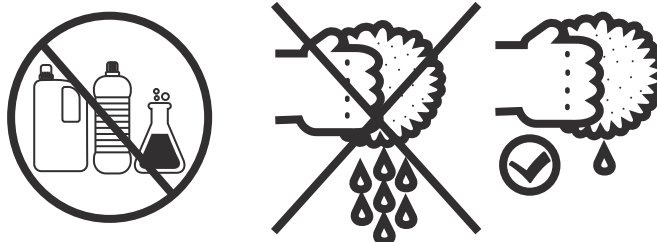
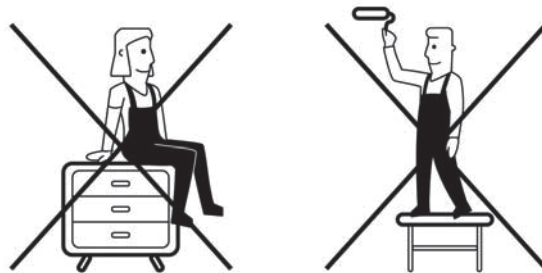
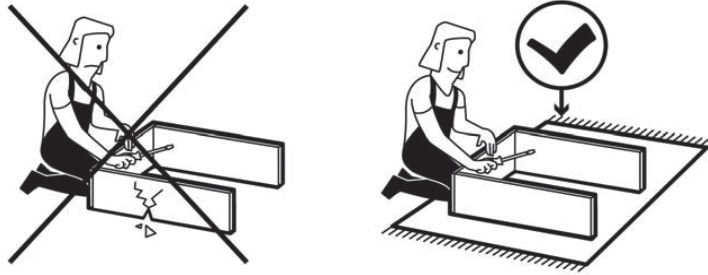
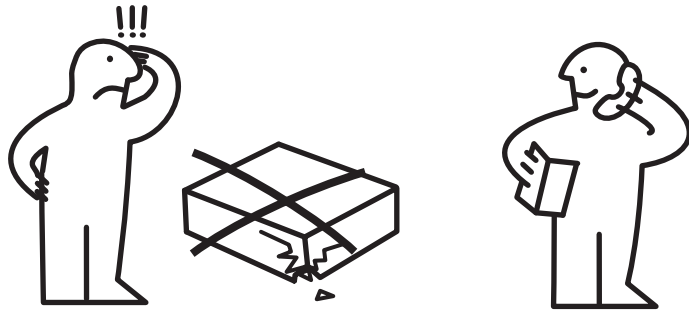
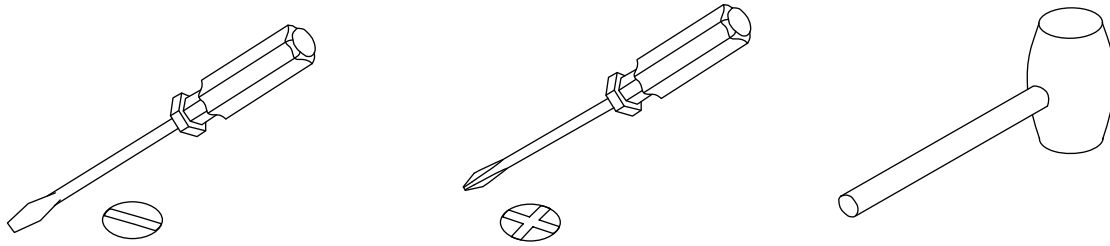

- * Before discarding packing materials, please check all parts and hardware are presented.
- * Please follow the instructions closely.
- * After few days of initial assembly, the product may has acclimated to new environment, please tighten all hardware again.

Dowel Installation

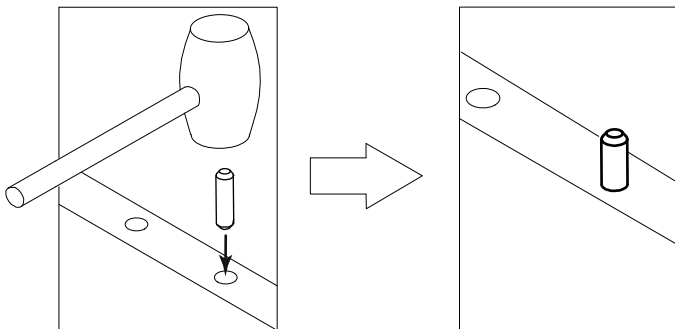

Gently tap dowel into hole with rubber mallet.

CAM-LOCK

Tighten until shoulder is flush with panel. Do not overtighten or undertighten

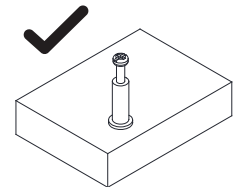
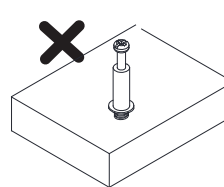
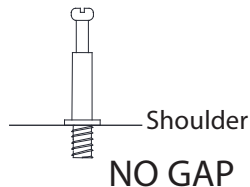

WHEN FITTING CAMS

ENSURE STARTING POSITION IS CORRECT BEFORE YOU INSERT CONNECTING CAM-PILLAR
TURN CLOCKWISE UNTIL SECURE

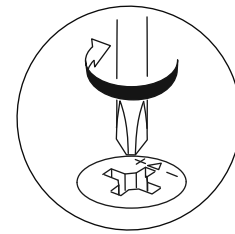
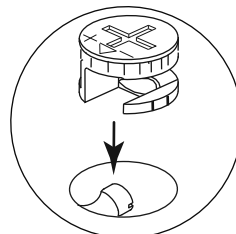
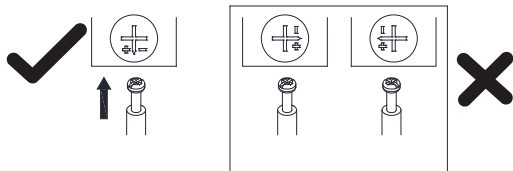

Laying out all the parts and hardware and identifying each part as shown below. It may help you when you assemble the item.

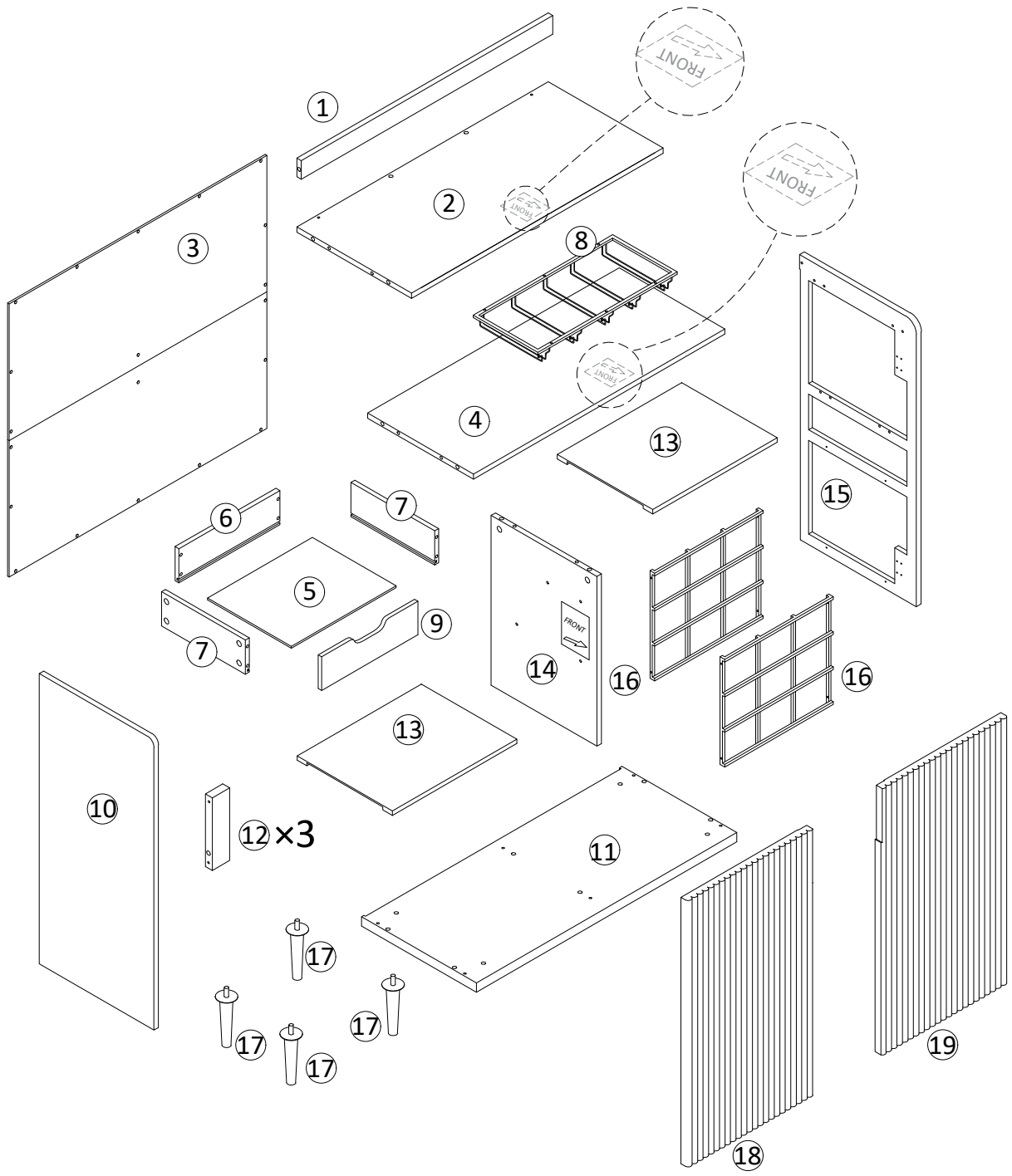

① × 1	② × 1	③ × 1	④ × 1	⑤ × 1	⑥ × 1	⑦ × 2	⑧ × 1
⑨ × 1	⑩ × 1	⑪ × 1	⑫ × 3	⑬ × 2	⑭ × 1	⑮ × 1	⑯ × 2
⑰ × 4	⑱ × 1	⑲ × 1					

1

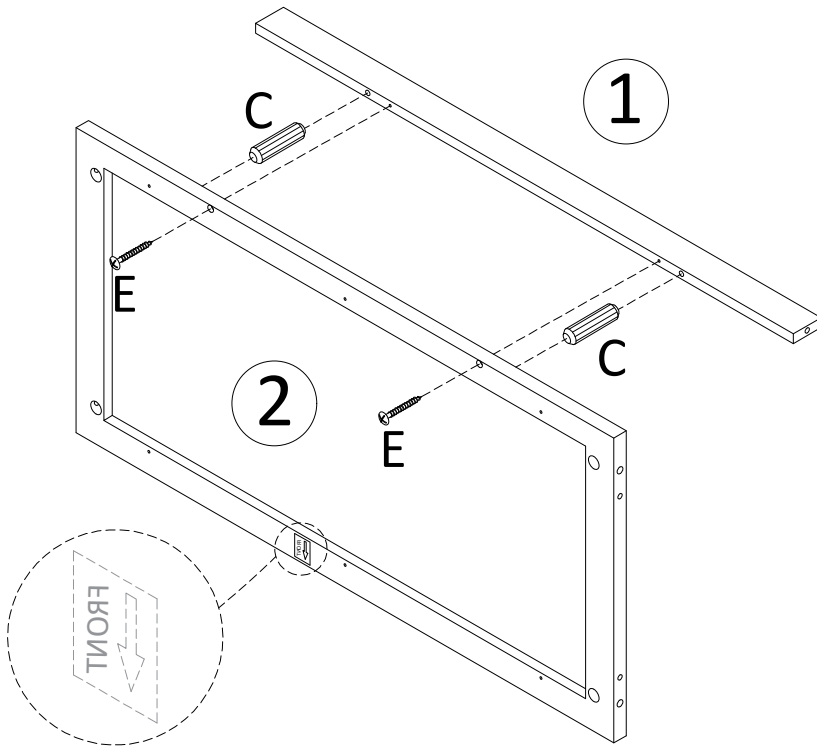

Turn the screws vertically from slow to fast.

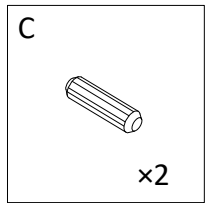
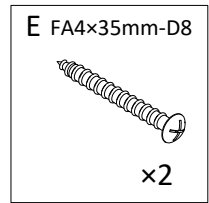

2

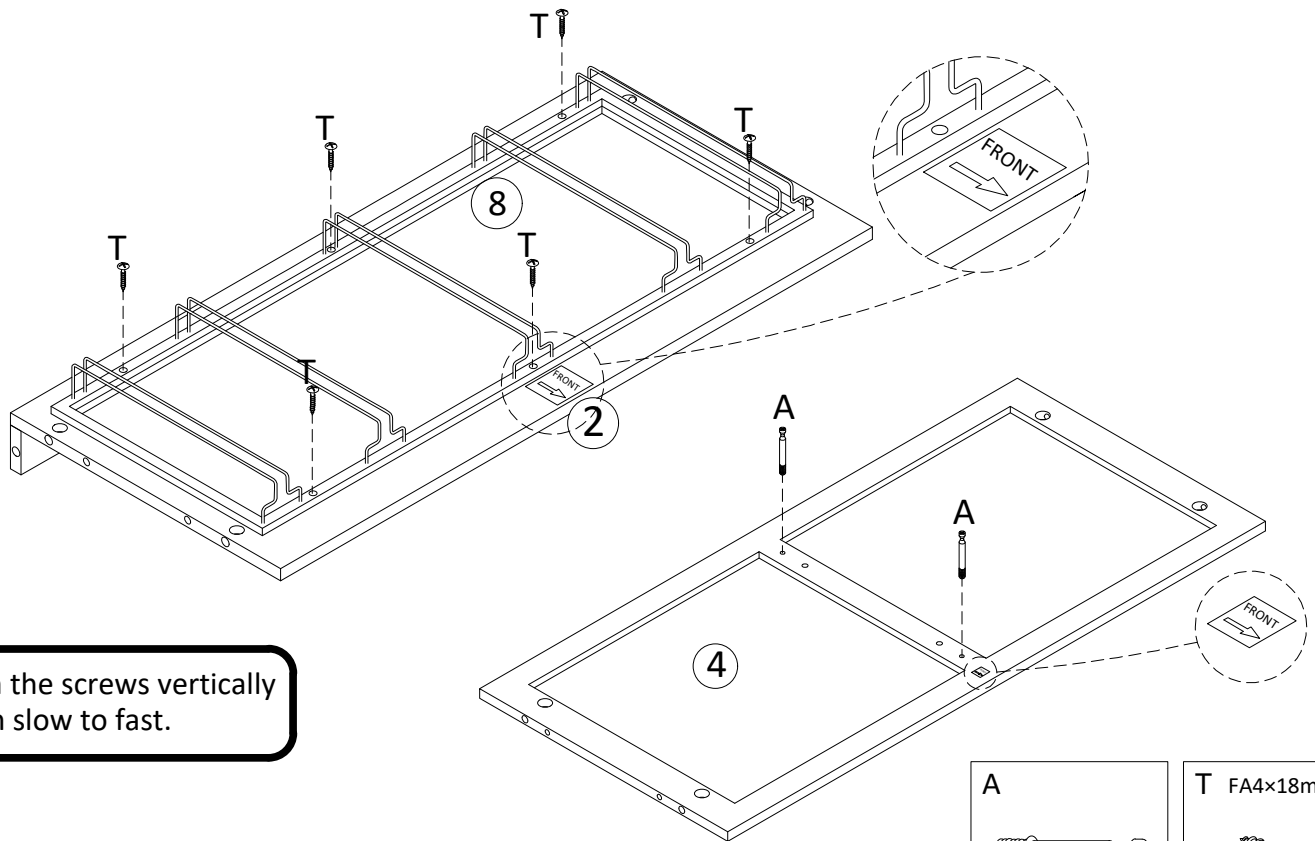

Turn the screws vertically from slow to fast.

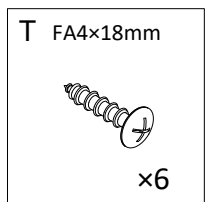
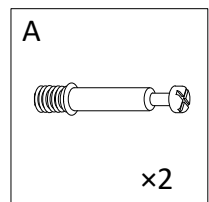

3

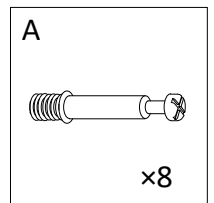
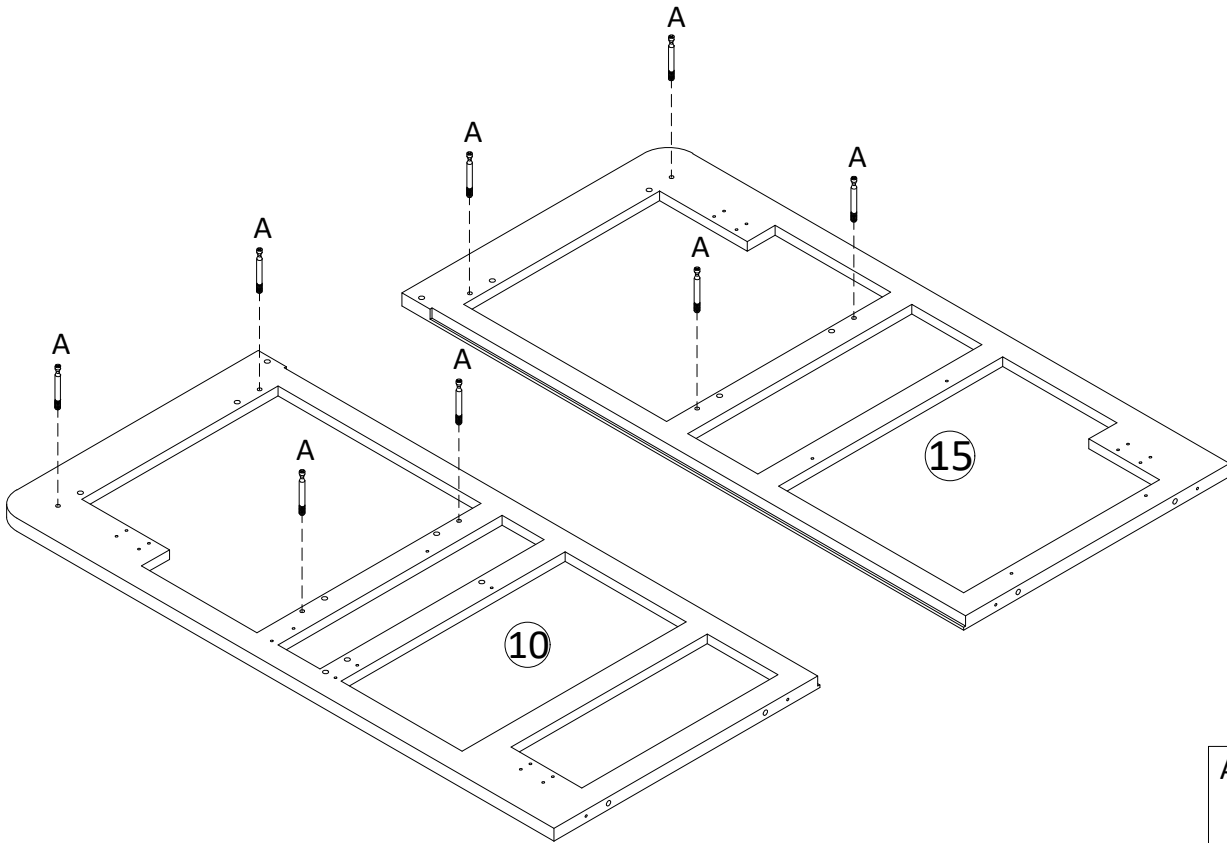

4

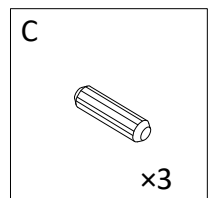
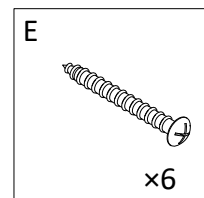
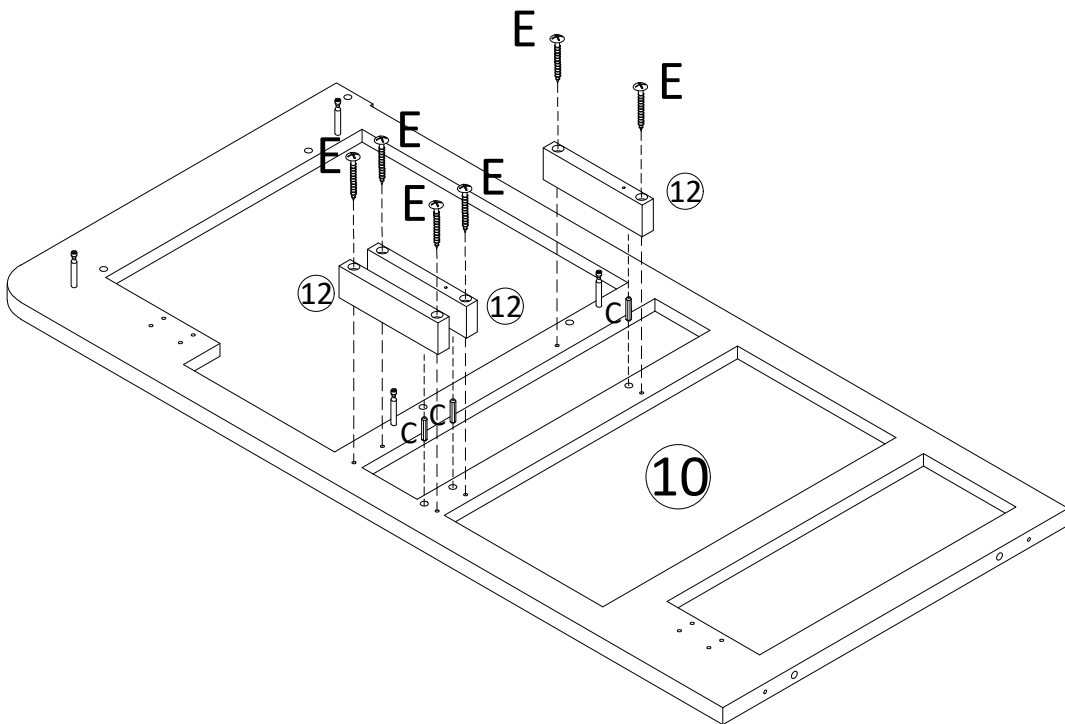

5

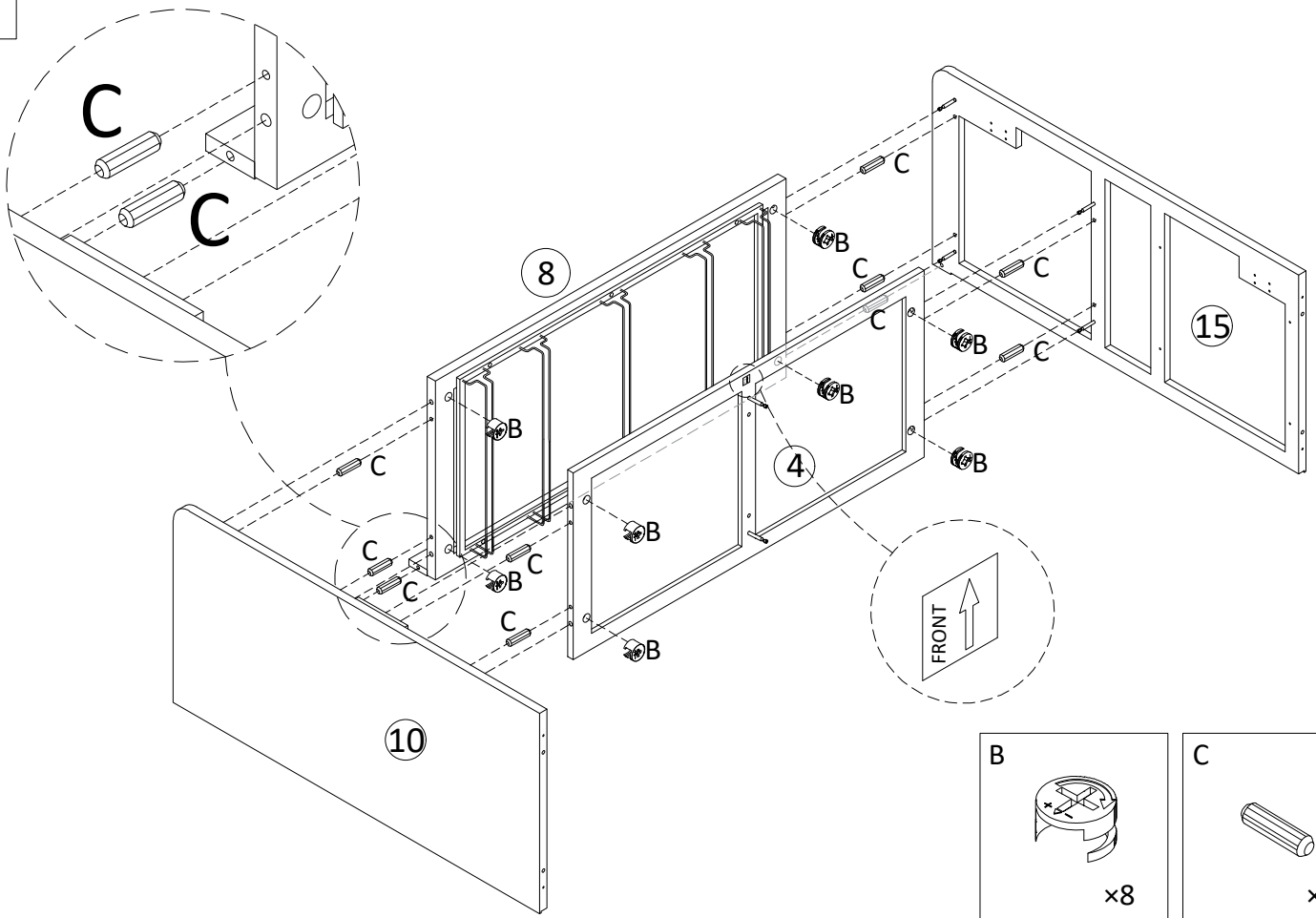

6

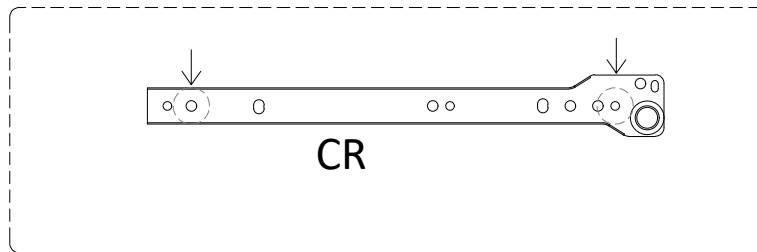

Turn the screws vertically from slow to fast.

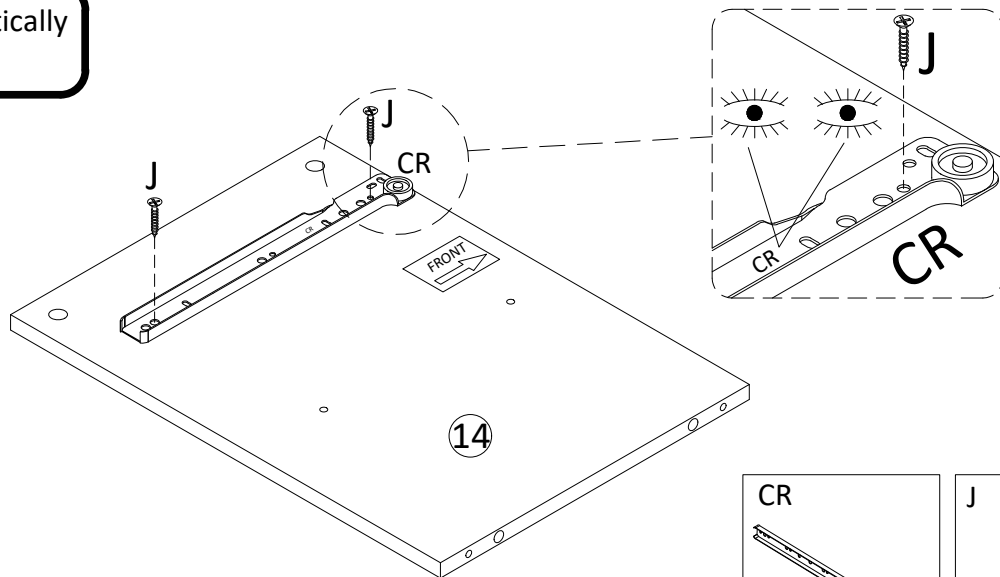

7

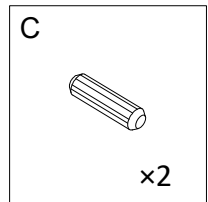
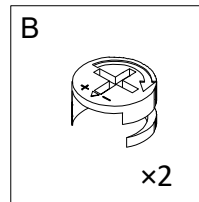
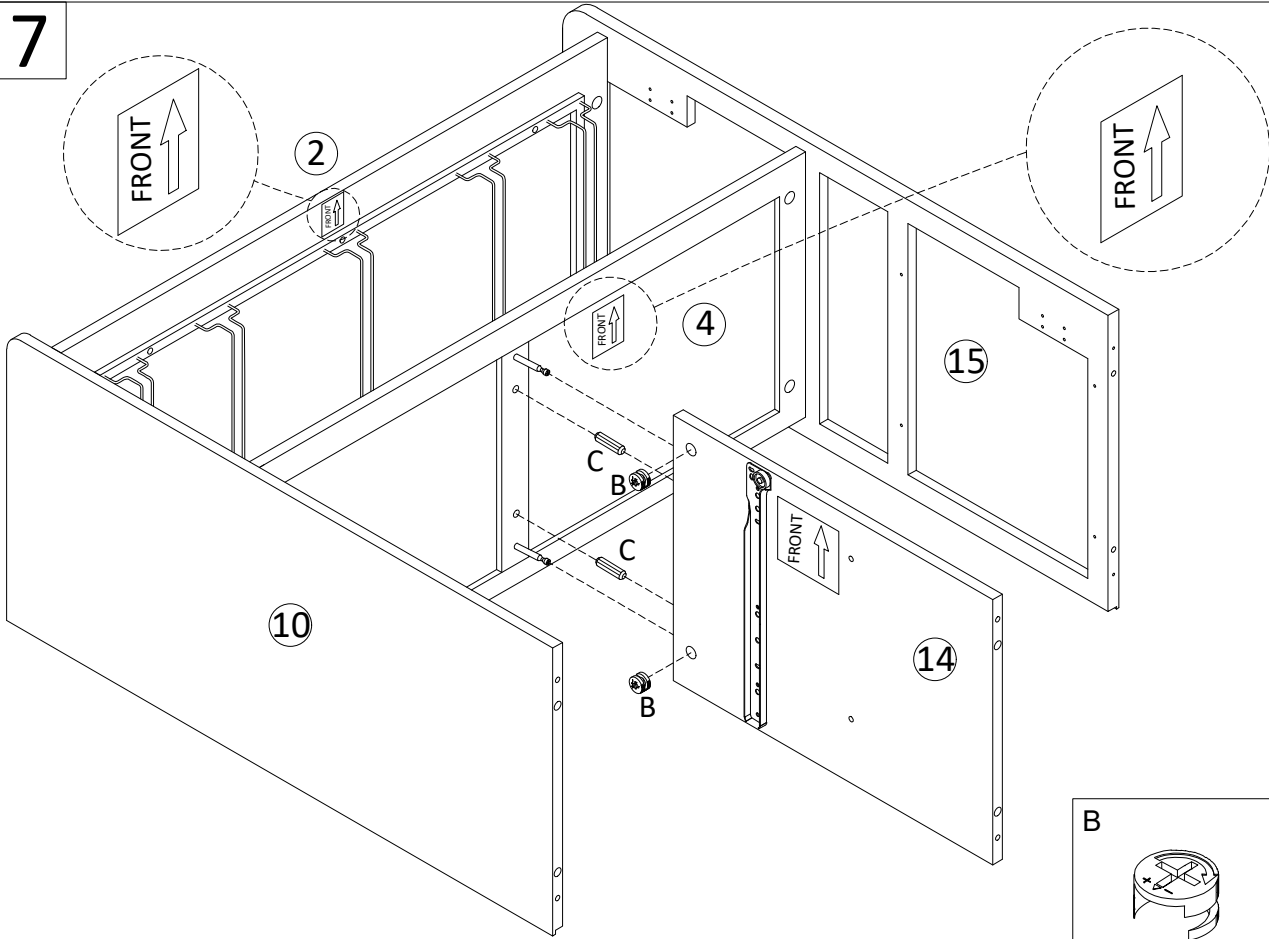

8

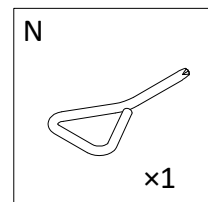
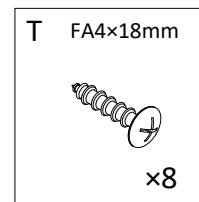
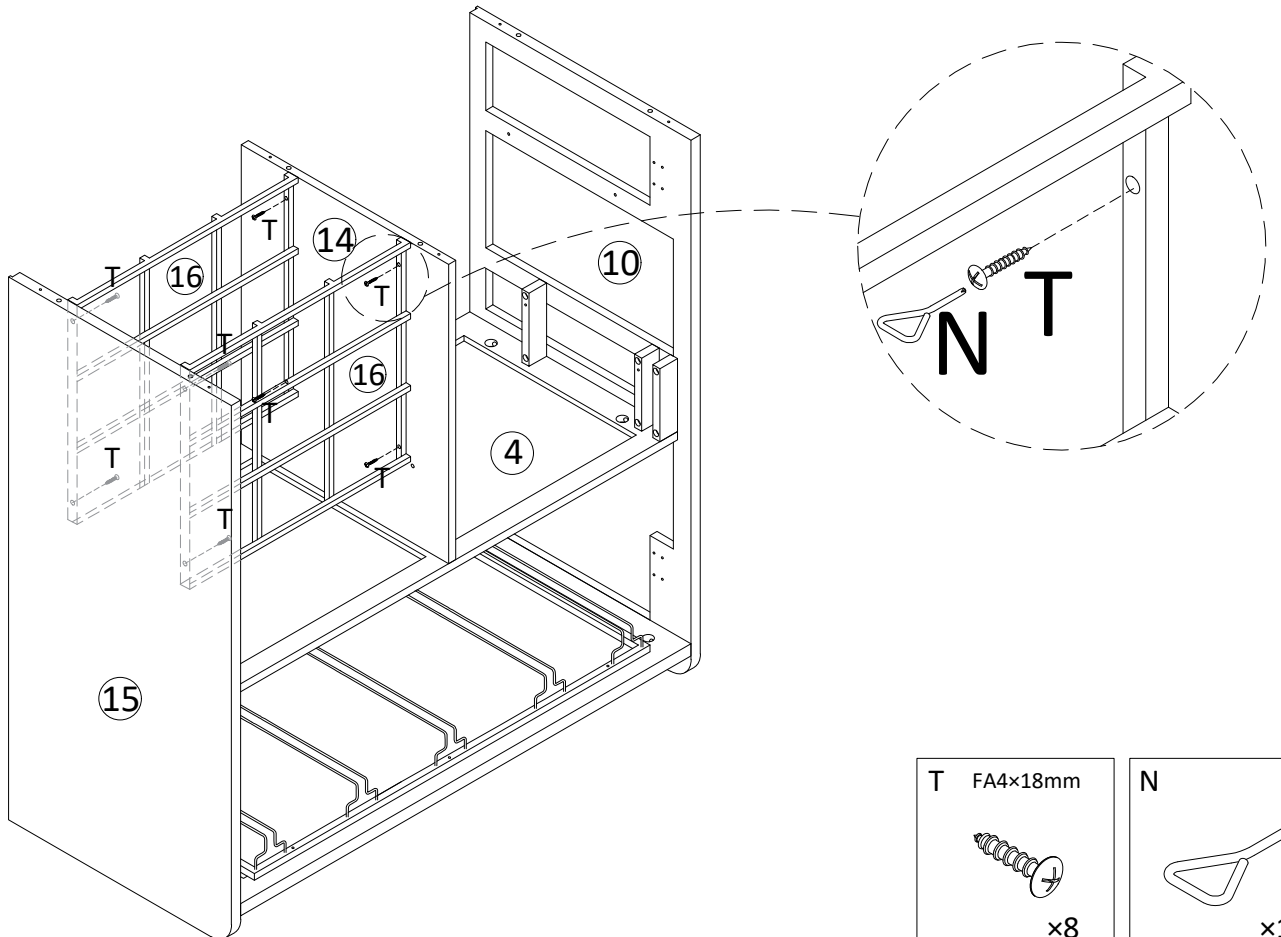

9

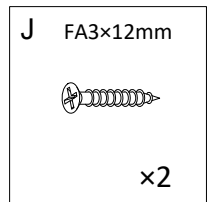
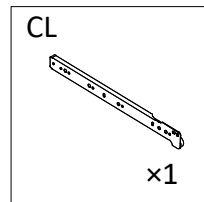
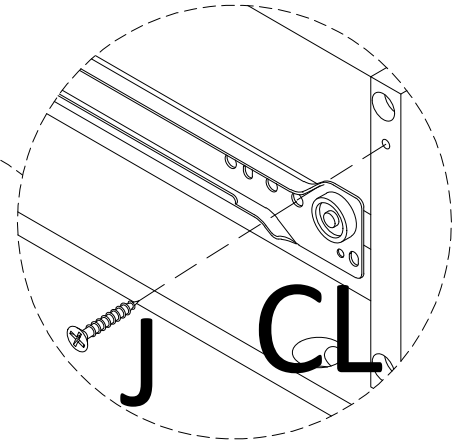
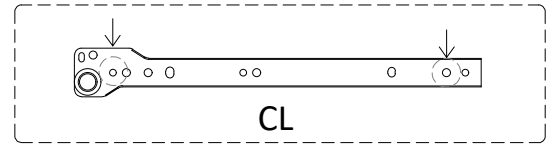
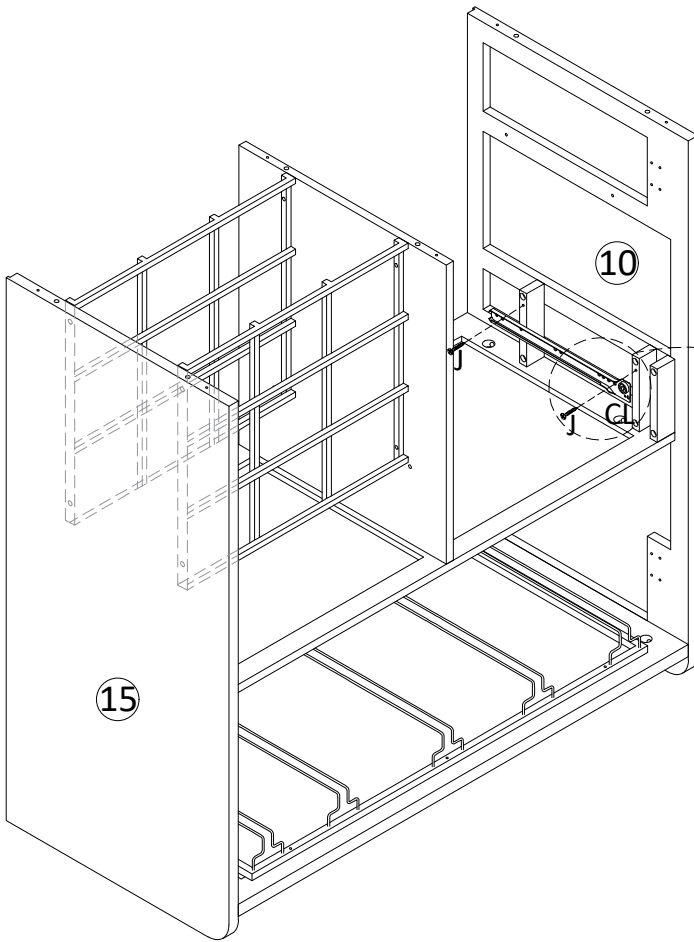



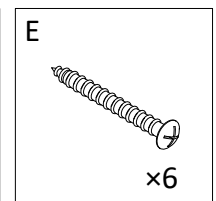
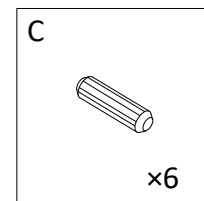
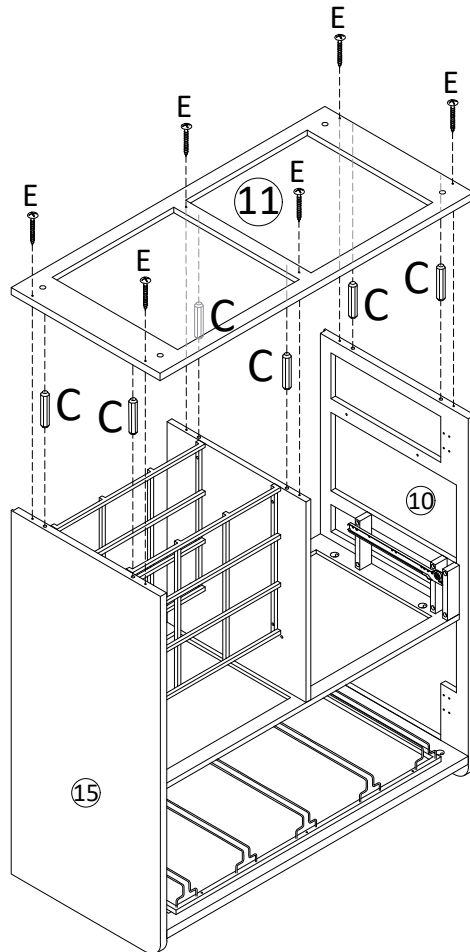

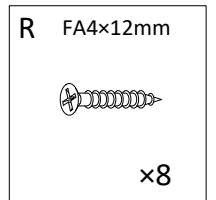
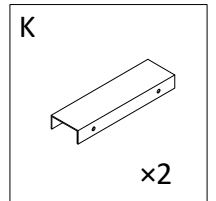
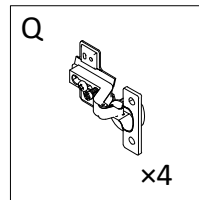
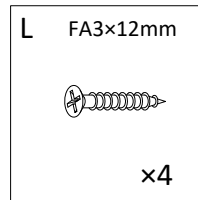
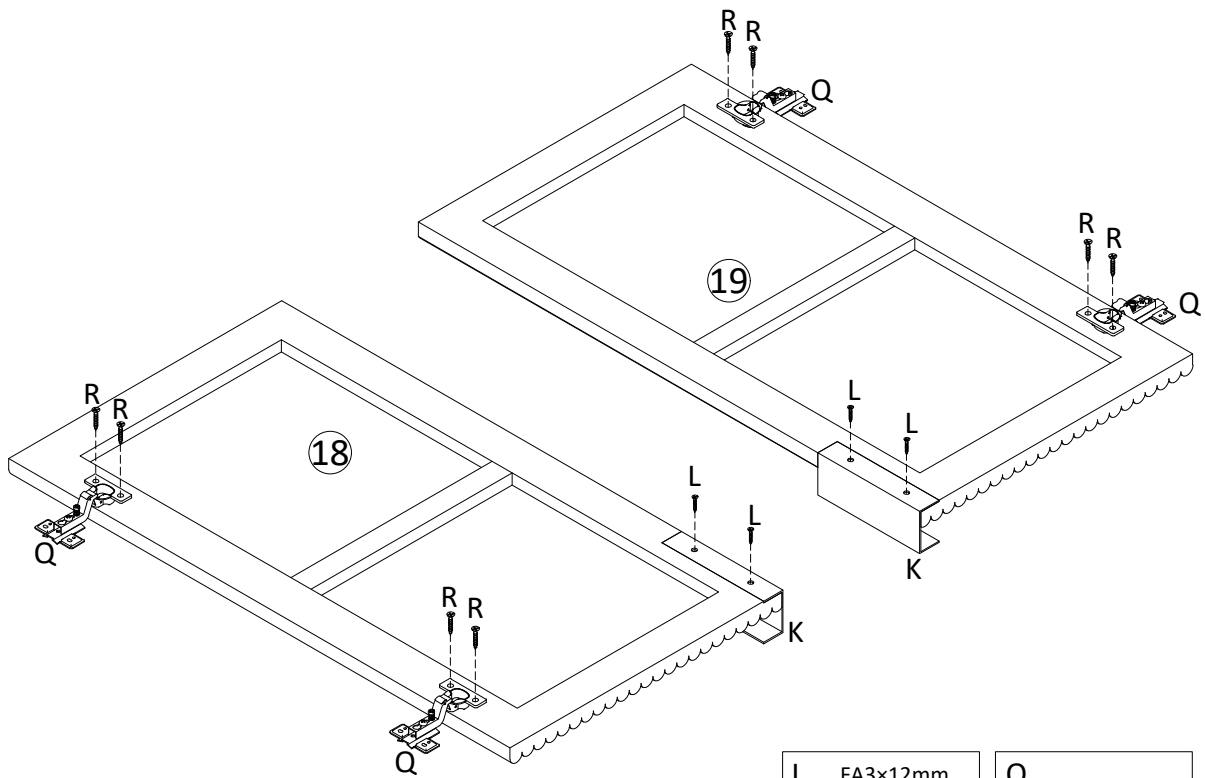
10

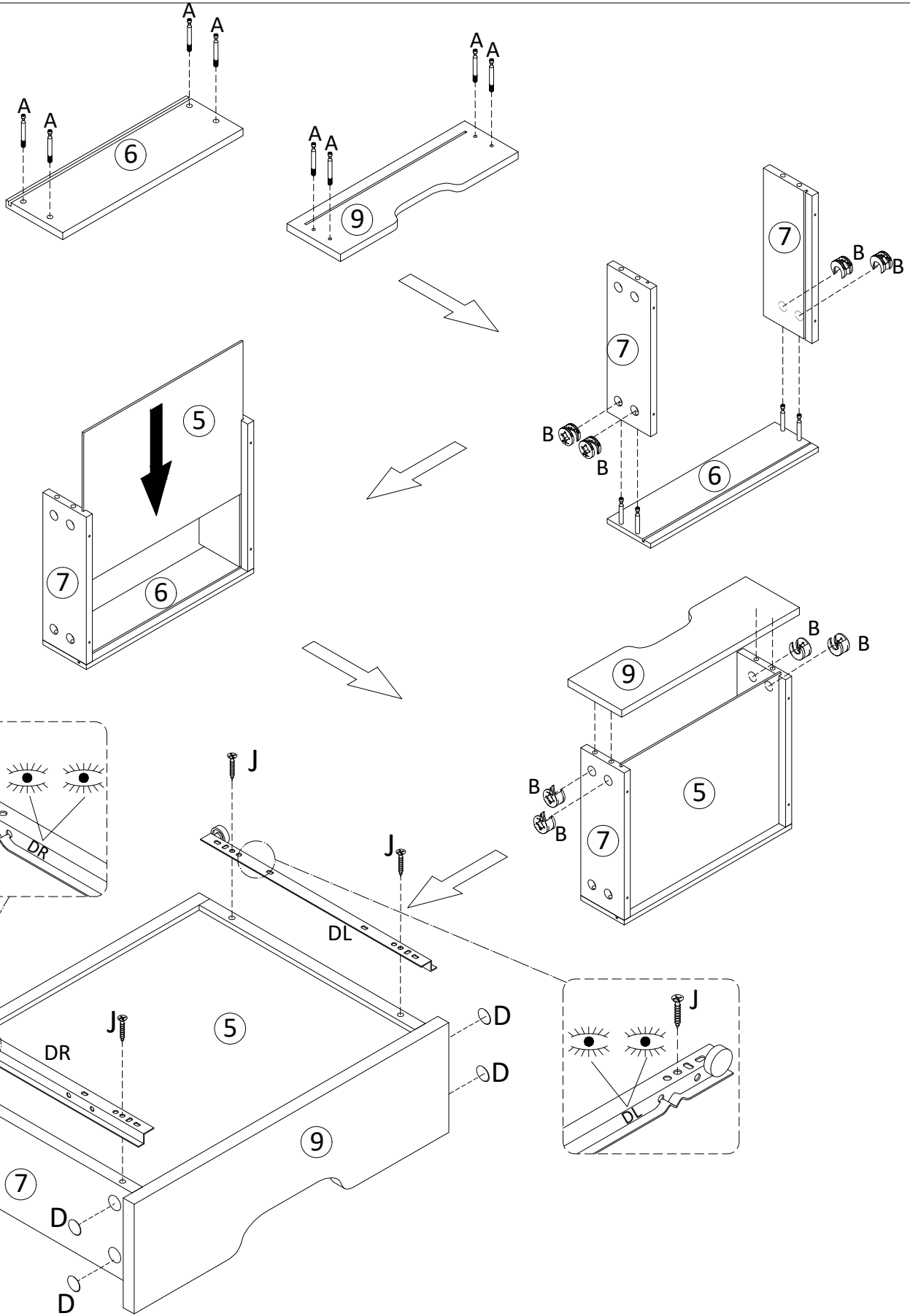

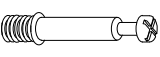

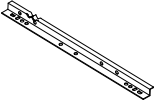

- | | | | | | |
|--|--|--|--|---|--|
| <p>D</p>  <p>x4</p> | <p>A</p>  <p>x8</p> | <p>B</p>  <p>x8</p> | <p>DL</p>  <p>x1</p> | <p>DR</p>  <p>x1</p> | <p>J</p>  <p>x4</p> |
|--|--|--|--|---|--|

15

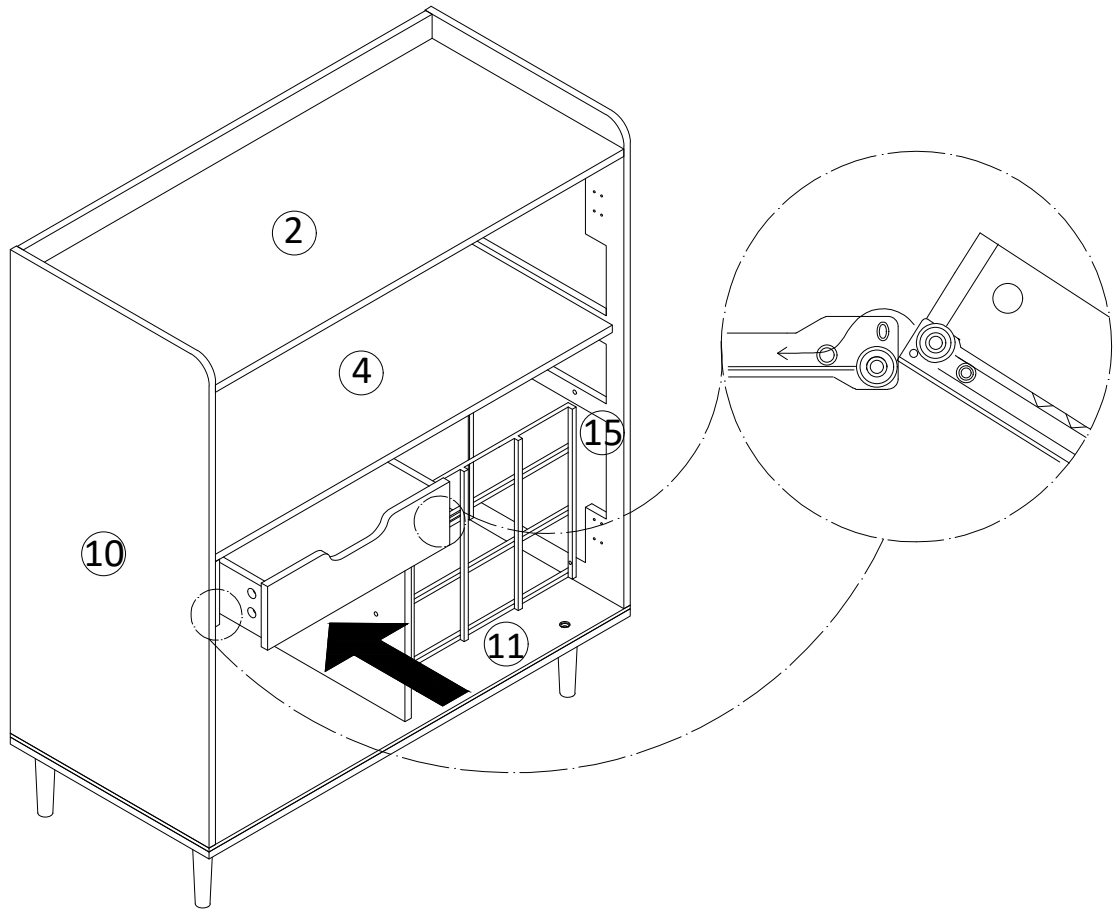

16

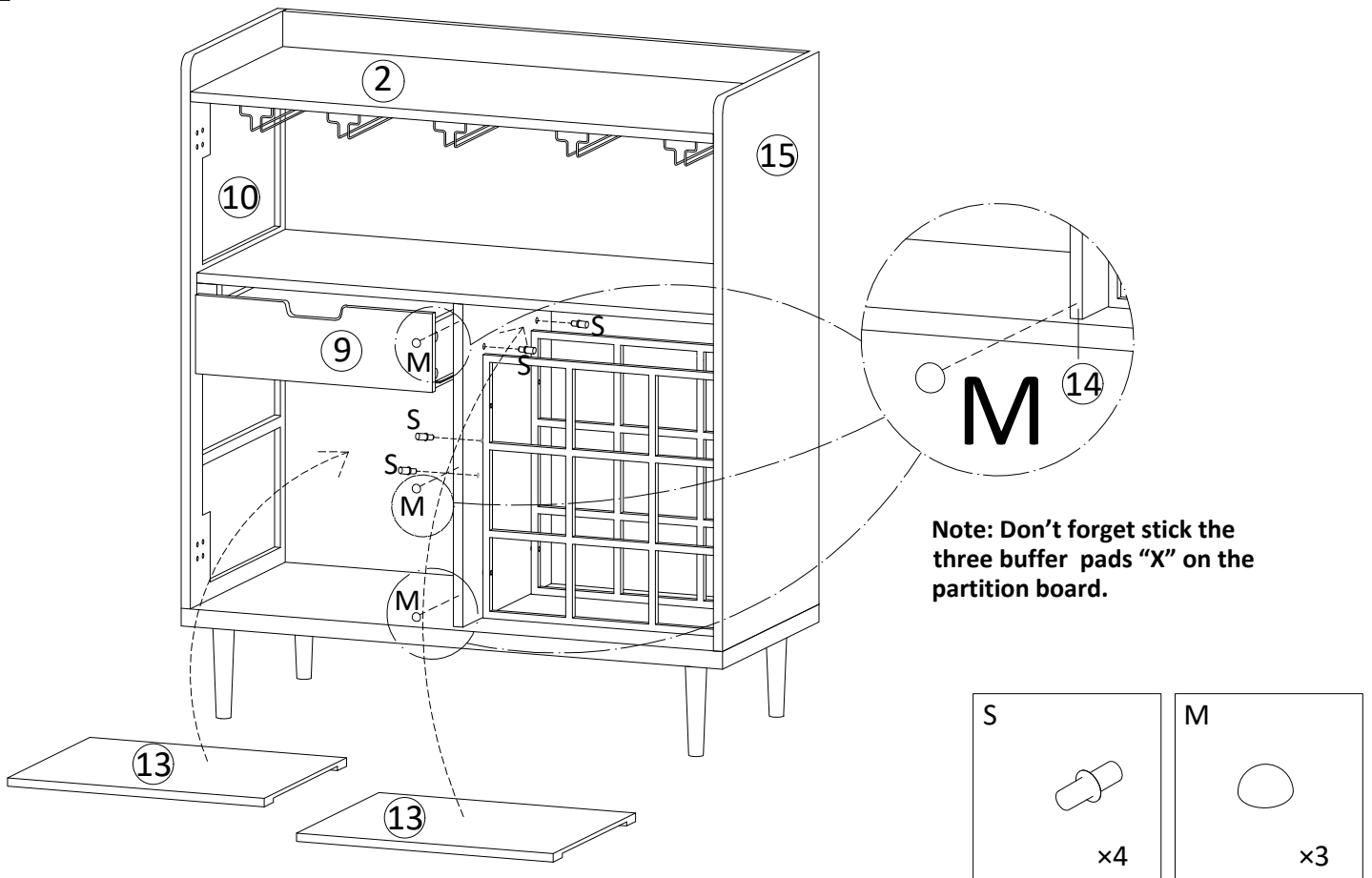

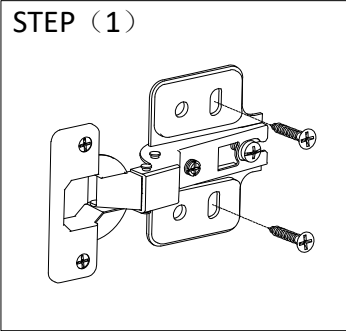

STEP (1)
Tips: Turning the screw to approx 50% tightness, don't be fully tight.

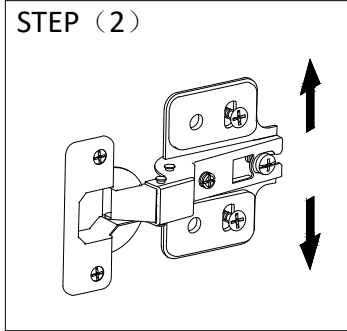

STEP (2)
Tips: Moving the hinges up or down appropriately to adjust the gap between the door with the cabinet top and bottom.

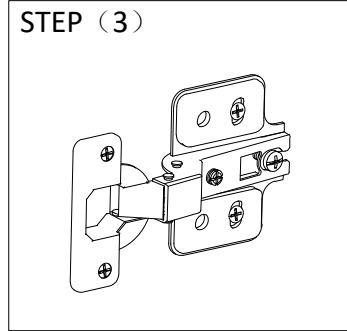

STEP (3)
Tips: Tightening the screws completely.

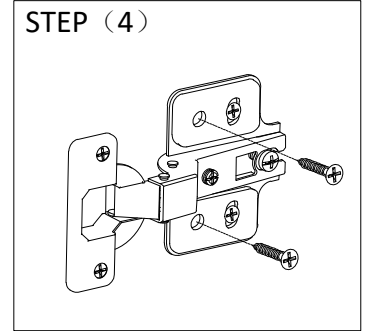

STEP (4)
Tips: Tightening the other screws completely.

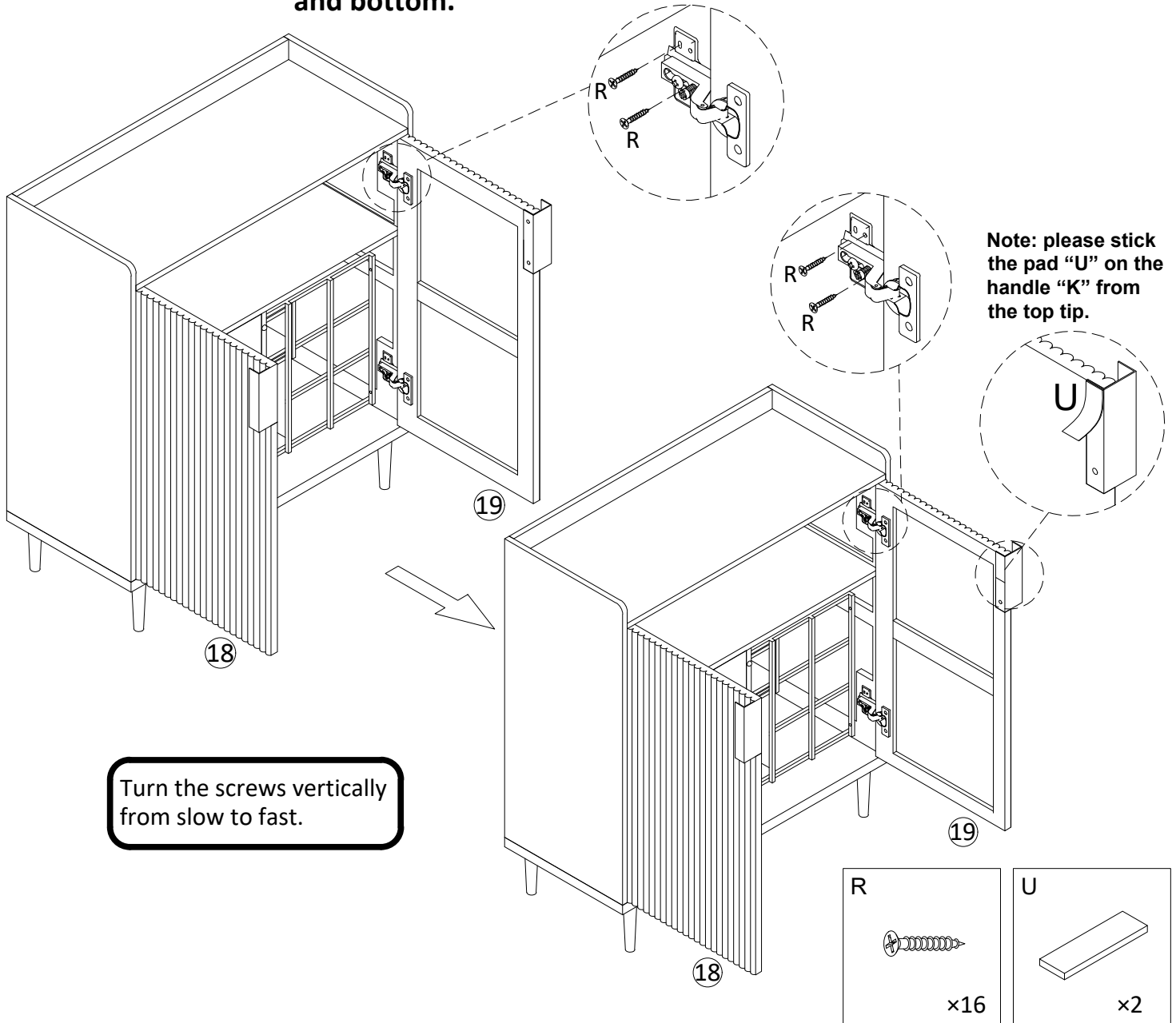

Note: please stick the pad "U" on the handle "K" from the top tip.

Turn the screws vertically from slow to fast.

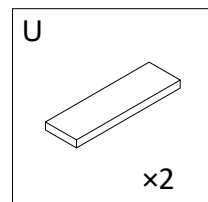
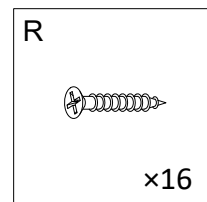

18 Tips: If the gap between two doors is too far or close, please turning the screw as shown below.

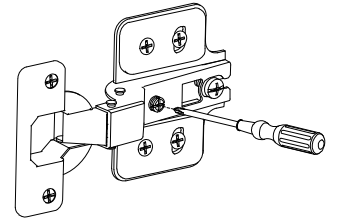
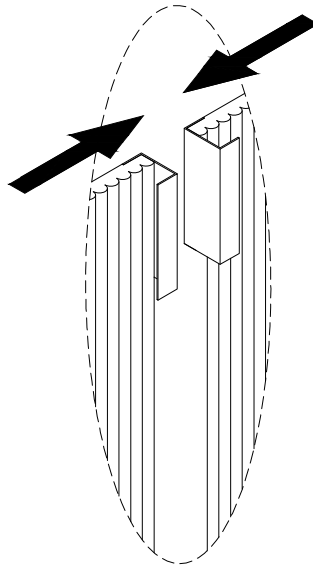
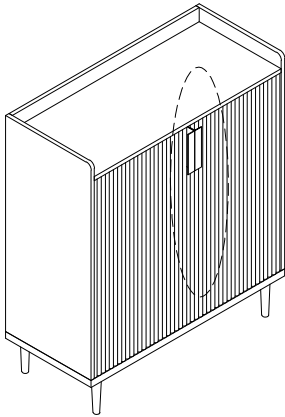

Tips: Adjusting the screw as shown in the following picture can make the door move forward or backward.

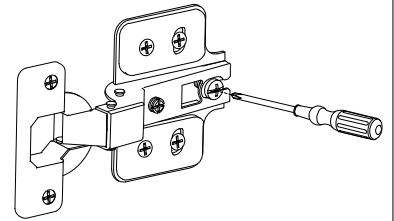
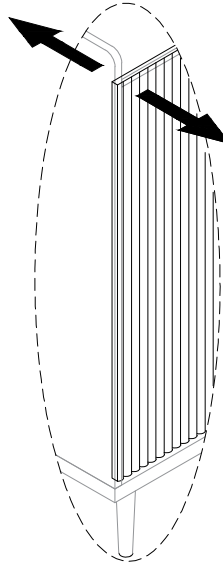
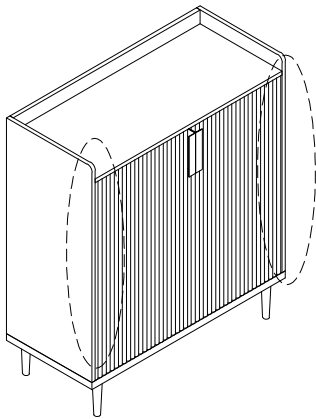

Tips: Adjusting the levelers appropriately underneath the bottom of the foot can make the gaps between the door and frames of cabinet even.

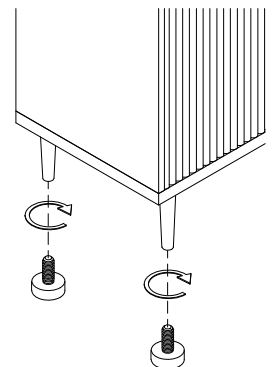
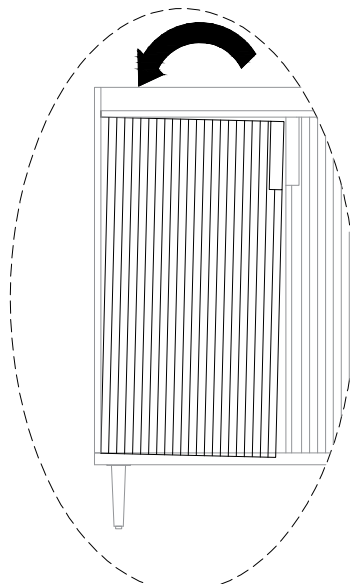
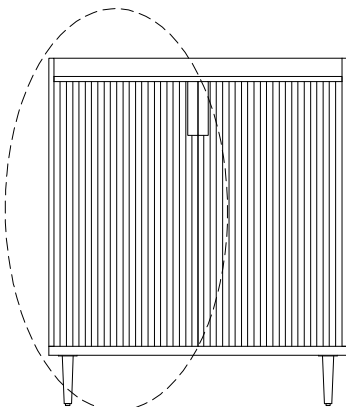

19

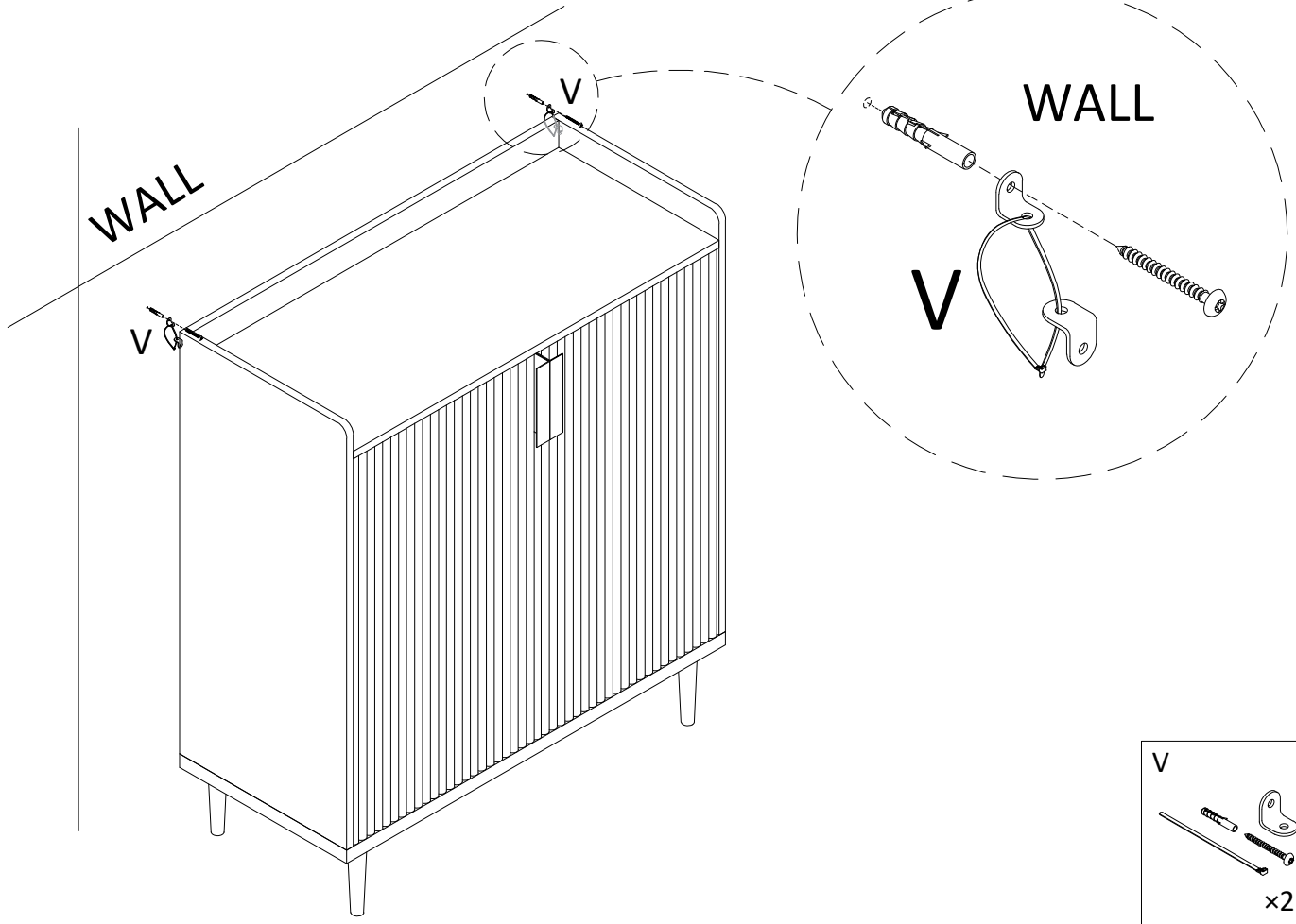

20

