

Assembly Instructions

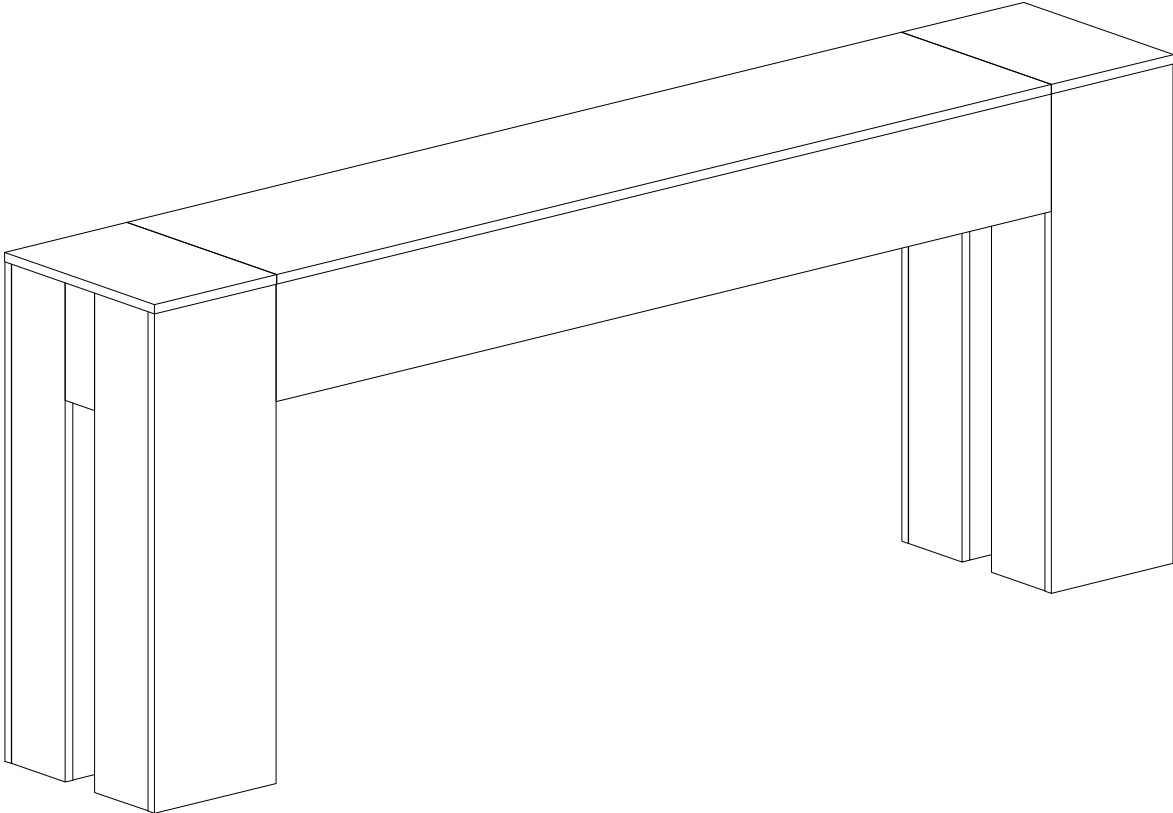

Contact Us

We're here to help you.

Your satisfaction is our top priority. If you encounter any issues with this product, such as missing or damaged parts, we're here to help. Please retain the original packaging and take photos of the packaging and the product, then contact us as soon as possible.

Warm Tips

1. Carefully read these instructions and keep them for future reference.
2. Check the parts list and confirm everything's there before starting assembly.
3. When assembling, put all parts on a soft, smooth surface like a carpet to avoid scratches.
4. Don't fully tighten screws until all parts are confirmed in place to avoid misalignment.

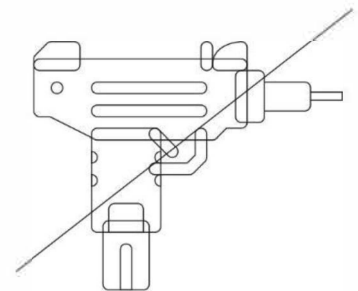
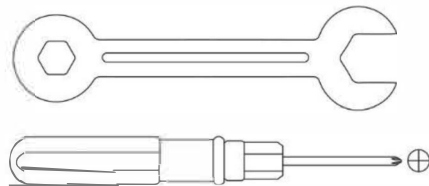
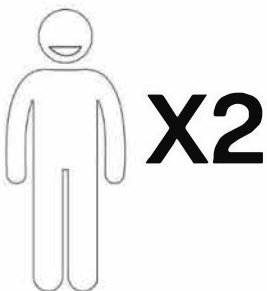

We recommend using hand tools for assembly.

If an electric screwdriver is used, reduce power and torque to avoid damage to the product.

AVOID SCRATCHES

In order to avoid scratching, this furniture should be assembled on a soft surface, such as a rug.

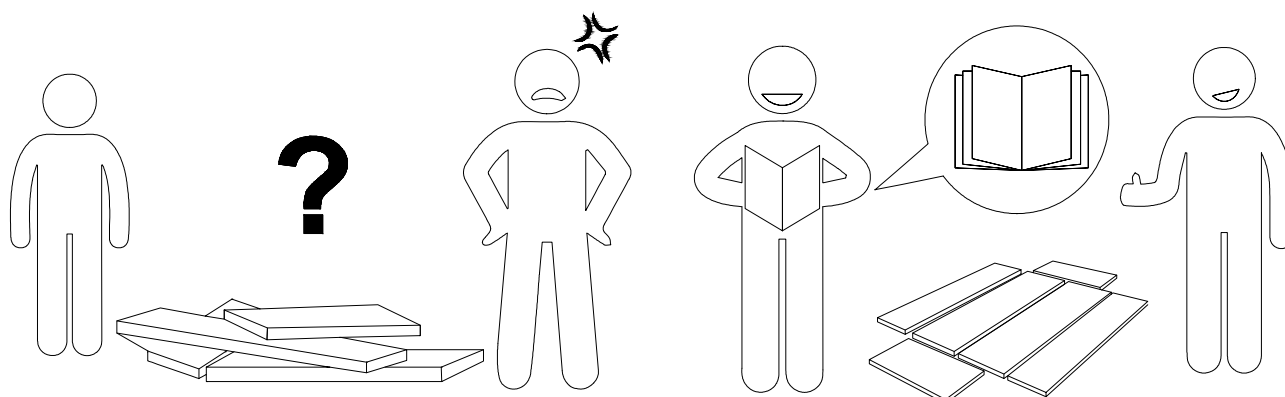
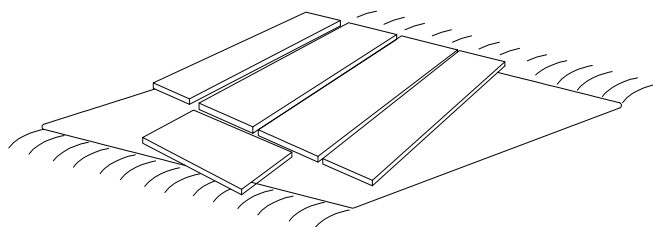
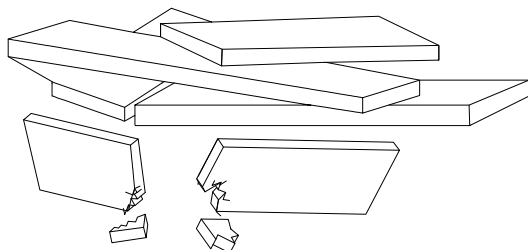

Install the Anti-Tip Straps

Using the anti-tip straps can reduce the risk of tipping over, but can not eliminate it.

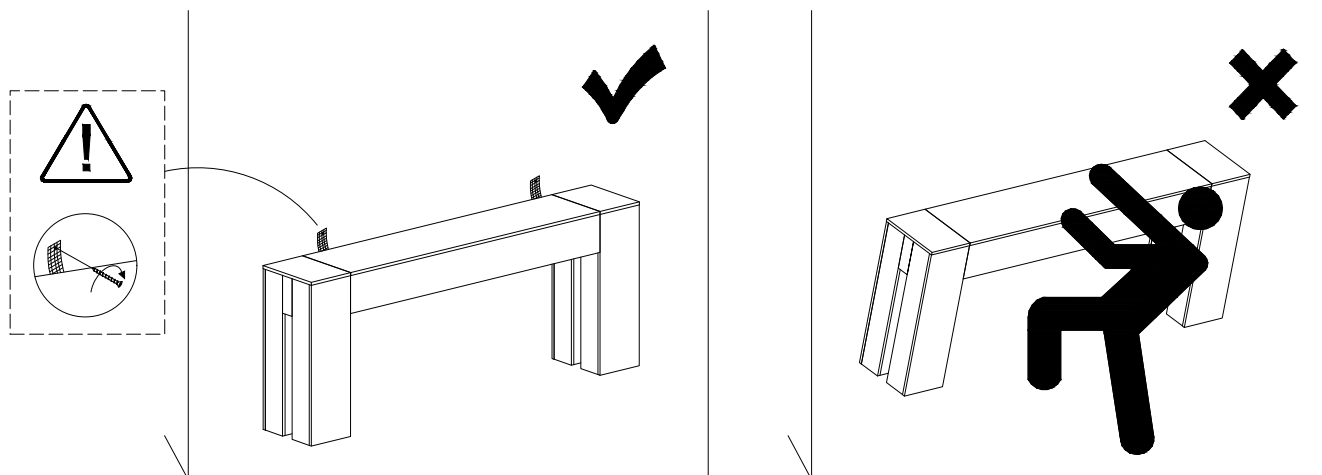

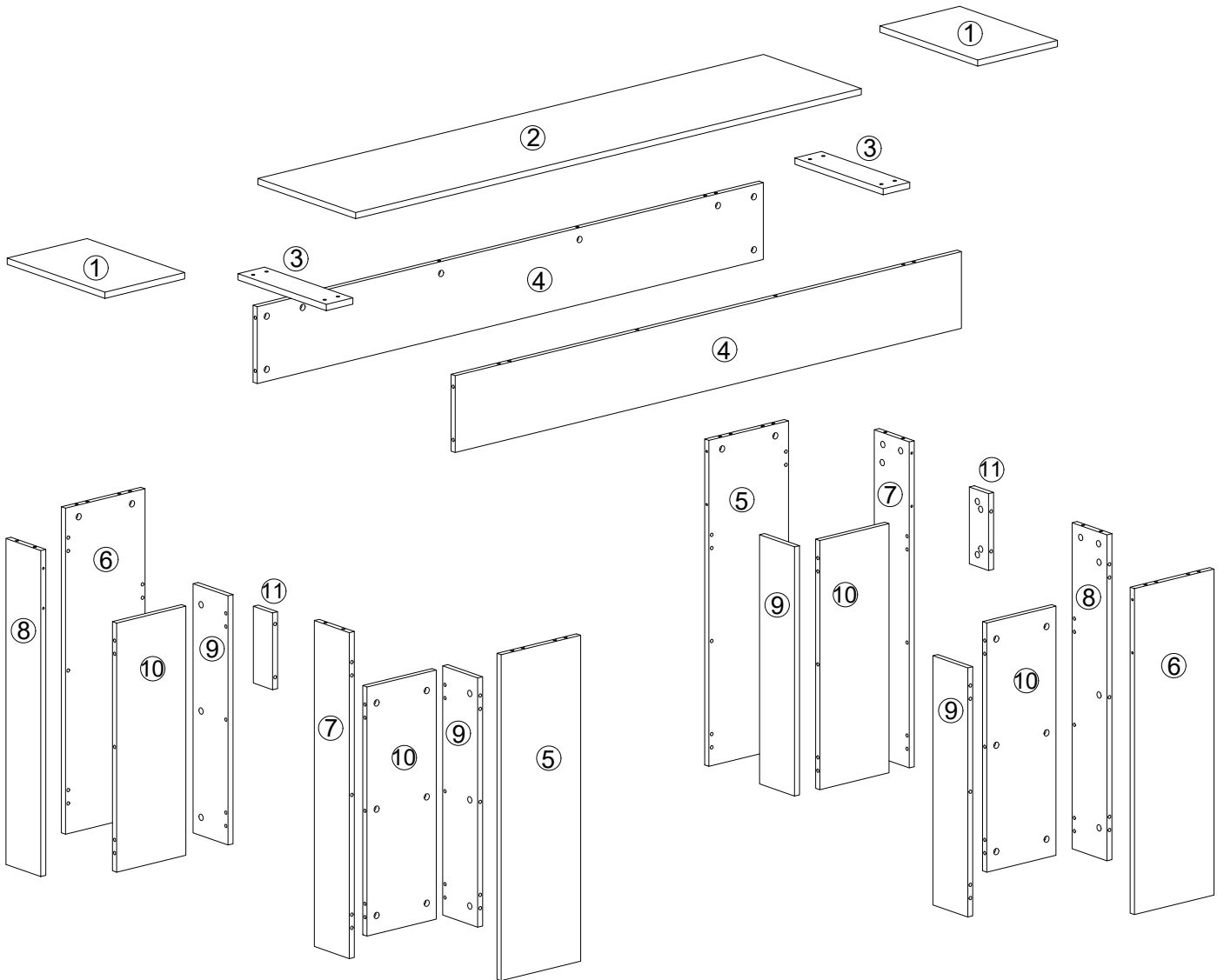





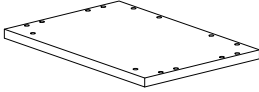
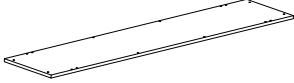
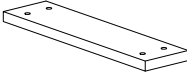
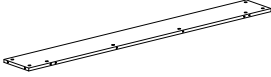
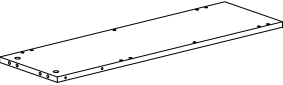
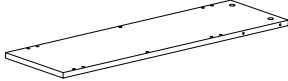
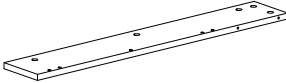
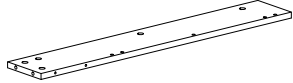
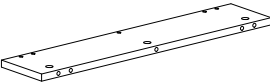
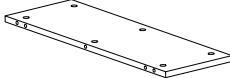
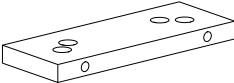

⚠ Caution

Make sure all parts are included. Most board parts are labeled or stamped on the raw edge. Contact us for a free replacement if you encounter any damaged or missing parts.

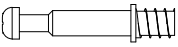
Parts List

			
① 2pcs	② 1pc	③ 2pcs	④ 2pcs
			
⑤ 2pcs	⑥ 2pcs	⑦ 2pcs	⑧ 2pcs
			
⑨ 4pcs	⑩ 4pcs	⑪ 2pcs	

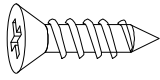
Hardware List

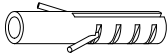
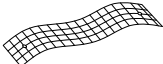
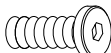
Ax88	Bx88	Cx44	Dx1	Ex2
				
Ø6X35mm	Ø15X12mm	Ø8X30mm	M4X64mm	Ø3.5X14mm
Fx2	Gx2	Hx2	Ix8	
				
Ø4X35mm	Ø8X40mm	155X20mm	M6X25mm	

Installation of Cams and Pins

Read each step carefully before starting. Each step of instruction should be performed in the correct order. If these steps are not followed in sequence, assembly difficulties may occur.

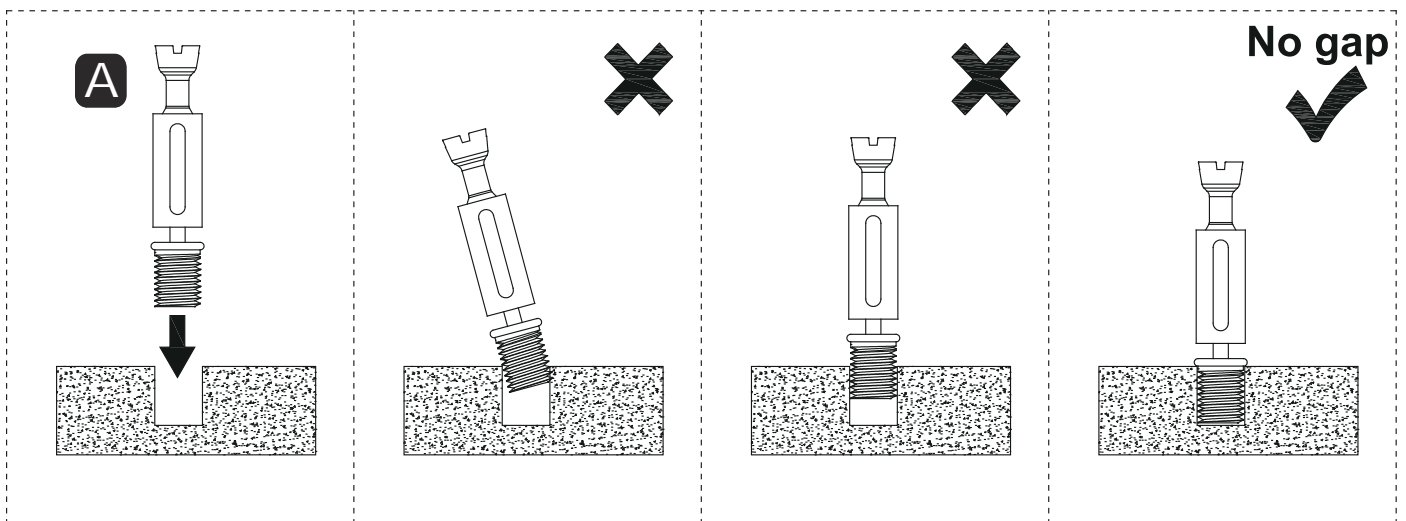
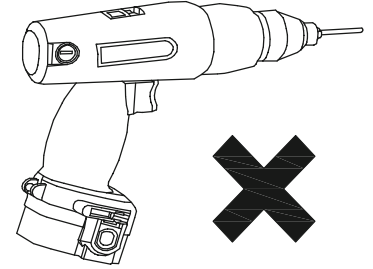

Screw the pin into the hole. Set the cams correctly by aligning the head of the cams with the lock pins. Lock the cam by turning the cam head with a screwdriver until it is tightened. Please do not use an electric screwdriver to assemble the unit.

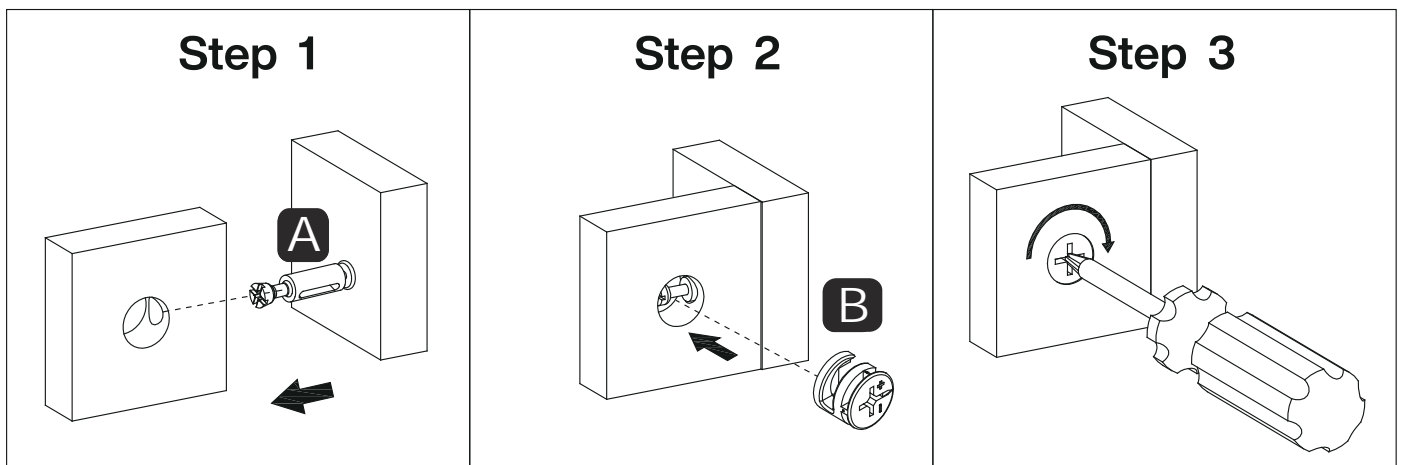

1

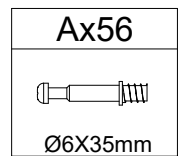
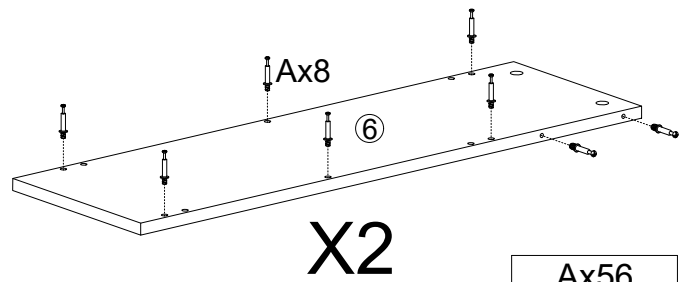
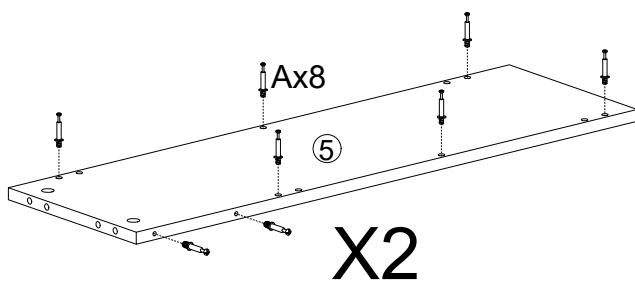
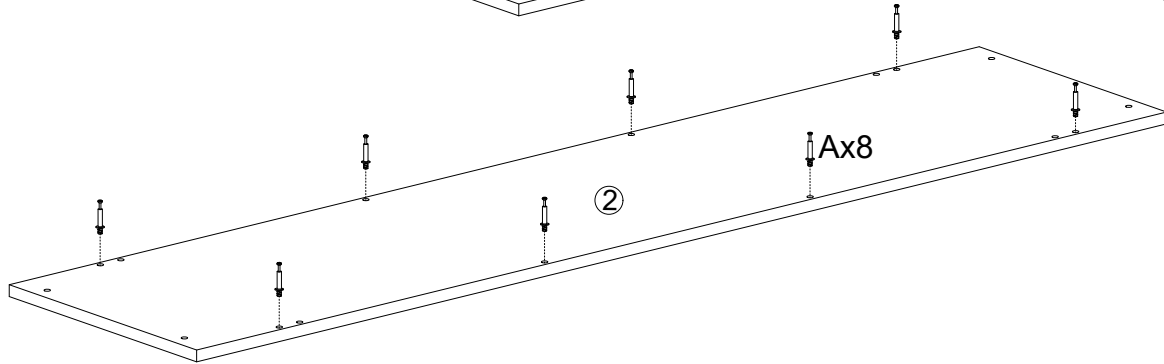
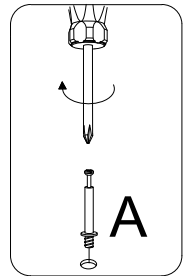
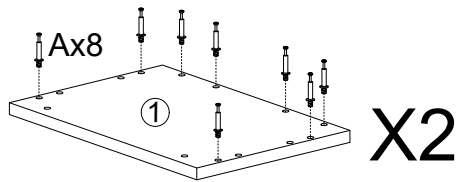

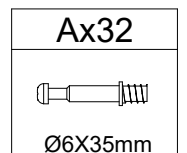
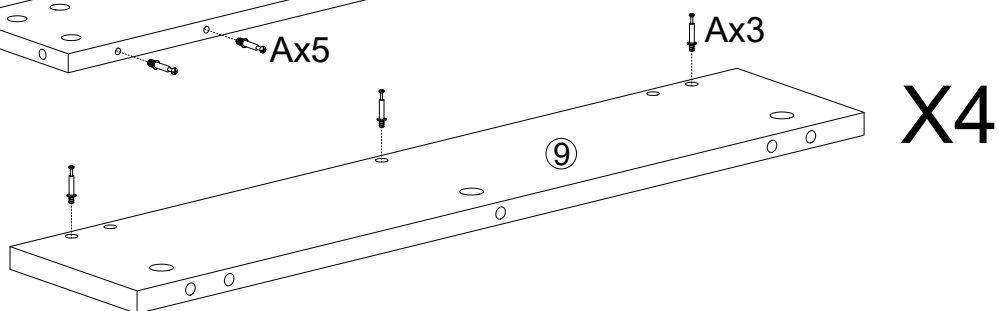
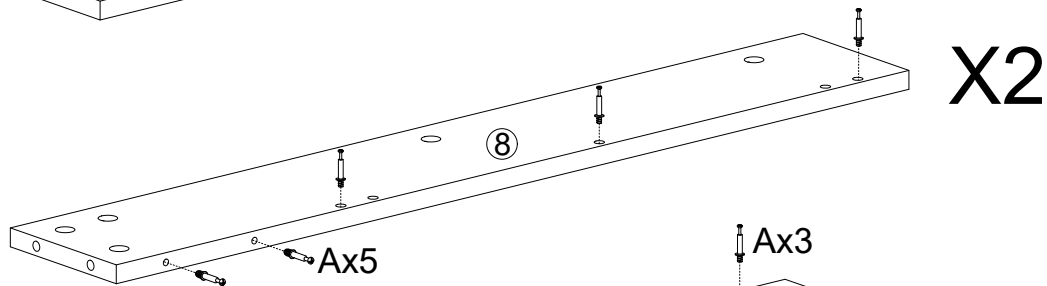
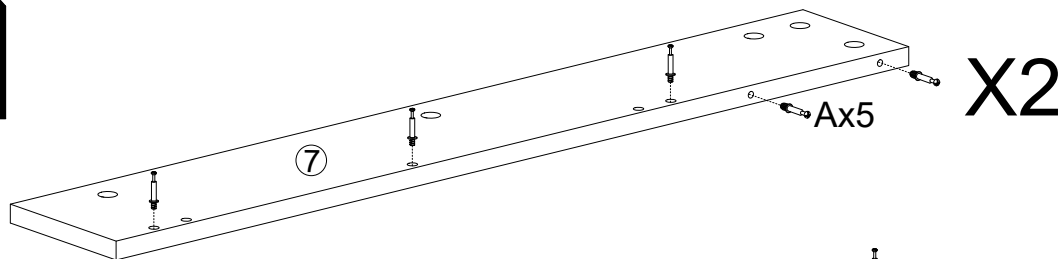

2

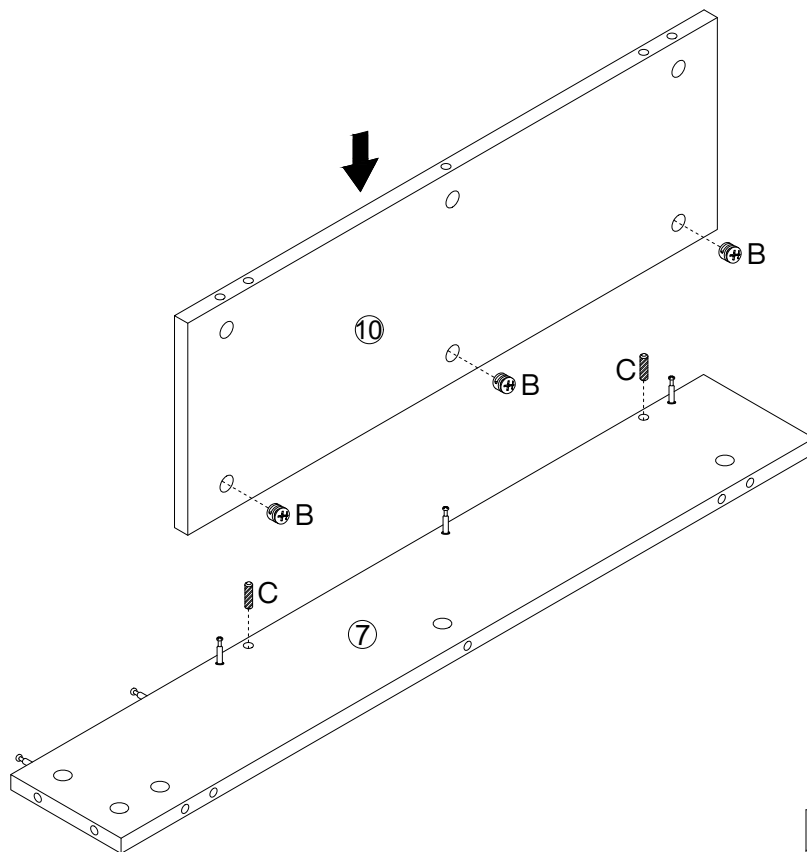

3





the step x2

Bx6	Cx4
	
Ø15X12mm	Ø8X30mm

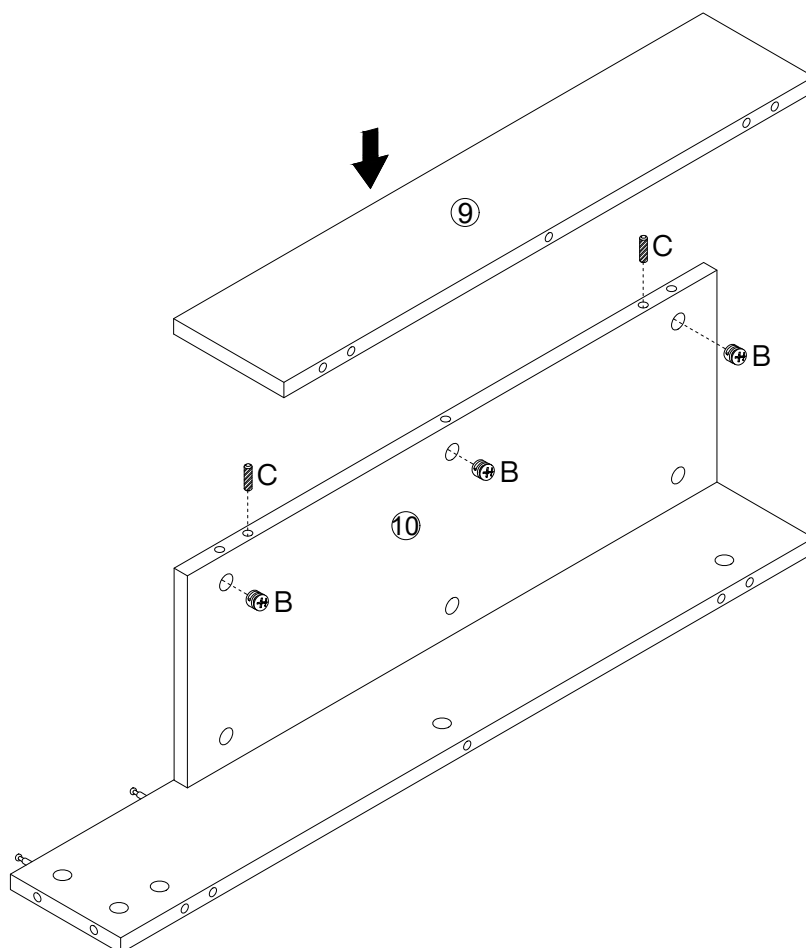
4





the step x2

Bx6	Cx4
	
Ø15X12mm	Ø8X30mm

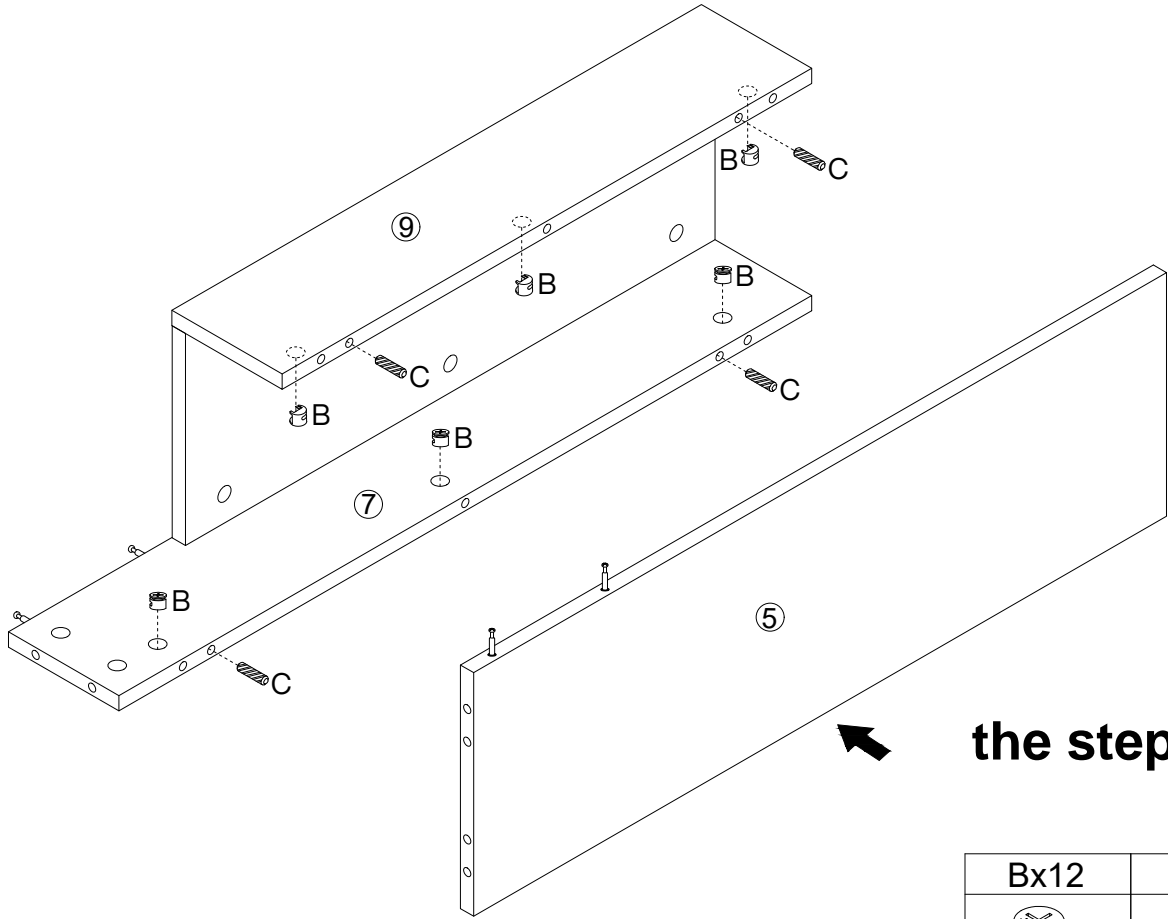
5





the step x2

Bx12	Cx8
	
Ø15X12mm	Ø8X30mm

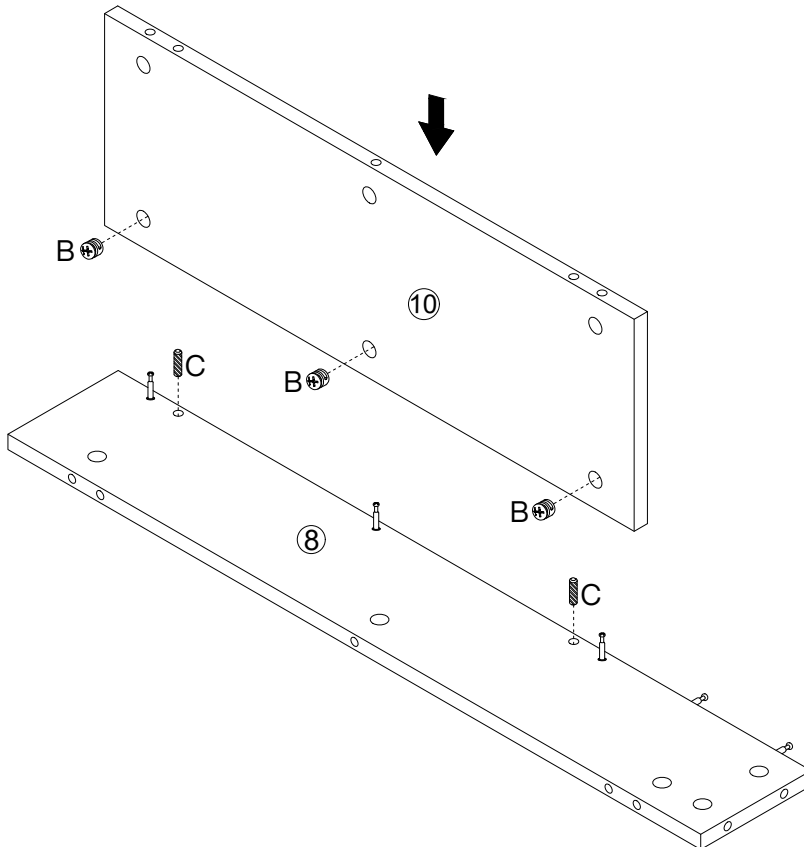
6





the step x2

Bx6	Cx4
	
Ø15X12mm	Ø8X30mm

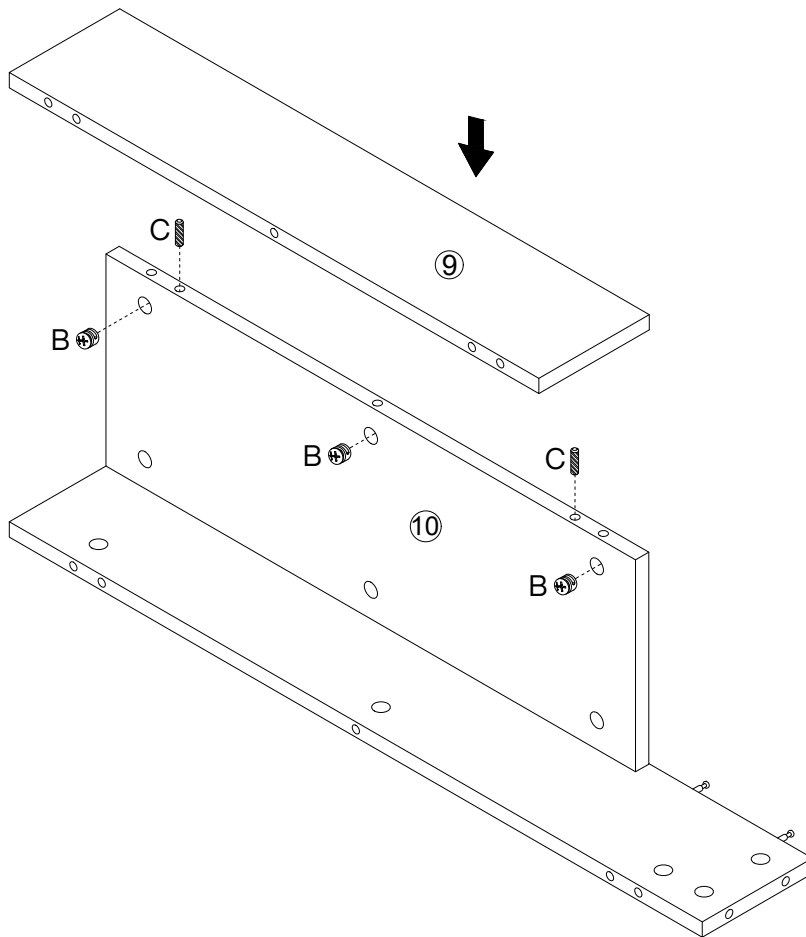
7





the step x2

Bx6	Cx4
	
Ø15X12mm	Ø8X30mm

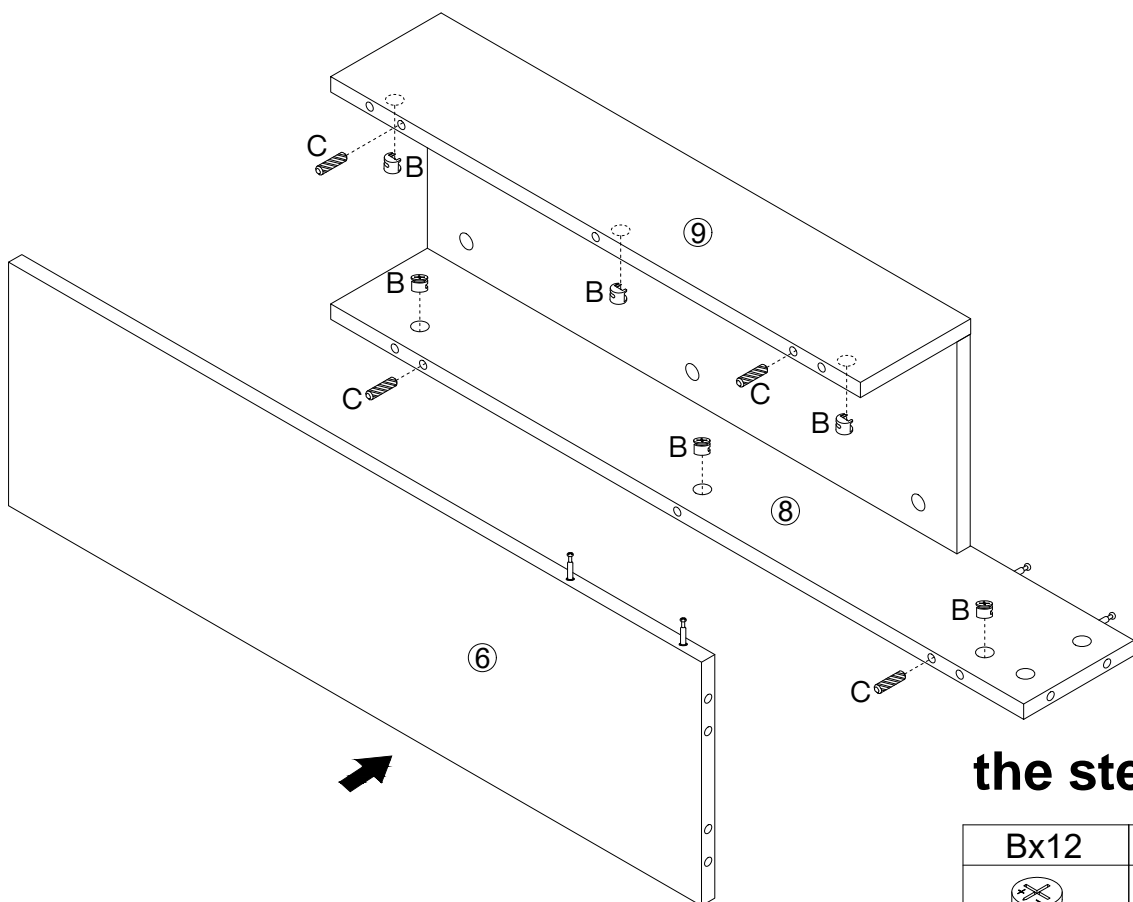
8



the step x2

Bx12	Cx8
	
Ø15X12mm	Ø8X30mm

9

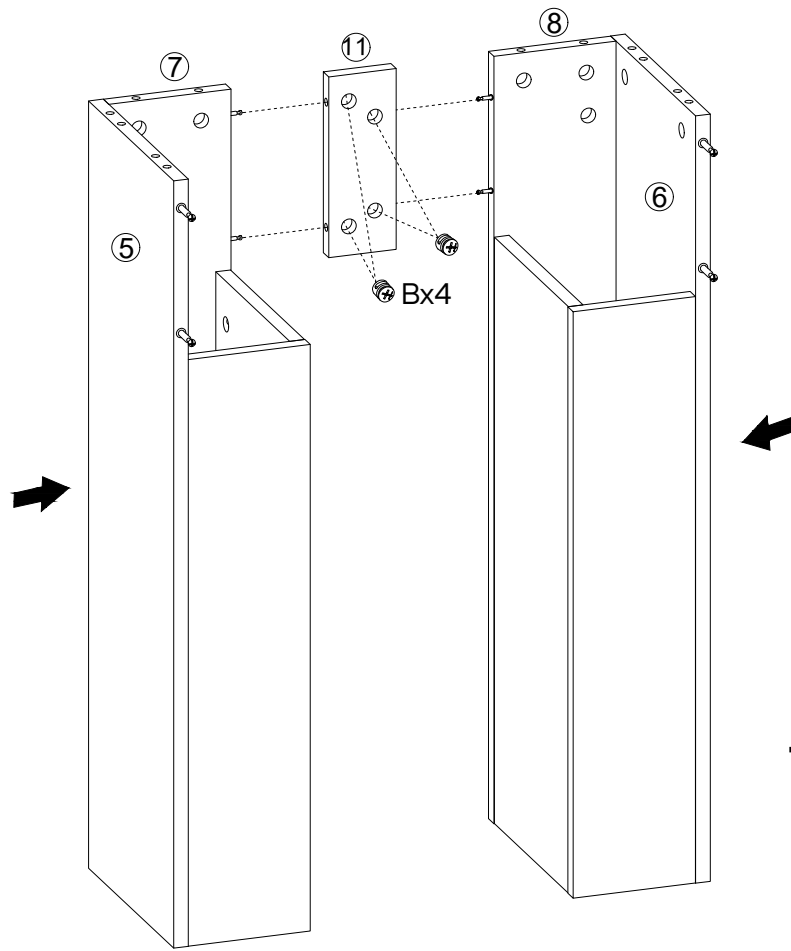



the step x2

Bx8

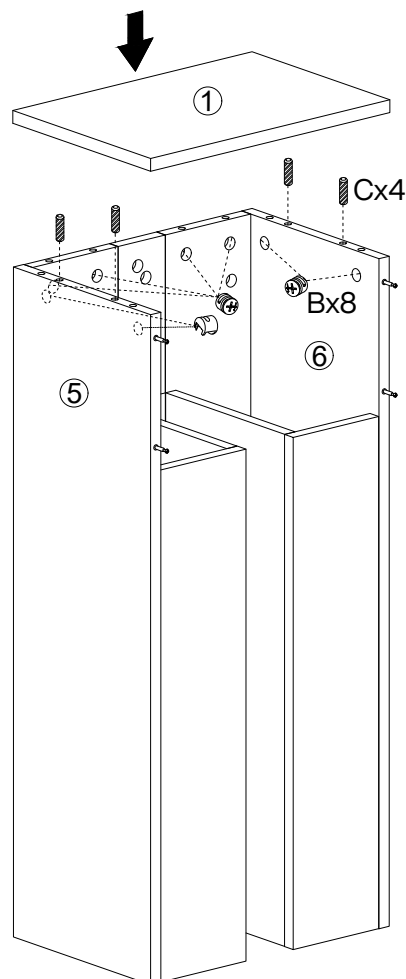
Ø15X12mm

10





the step x2

Bx16	Cx8
	
Ø15X12mm	Ø8X30mm

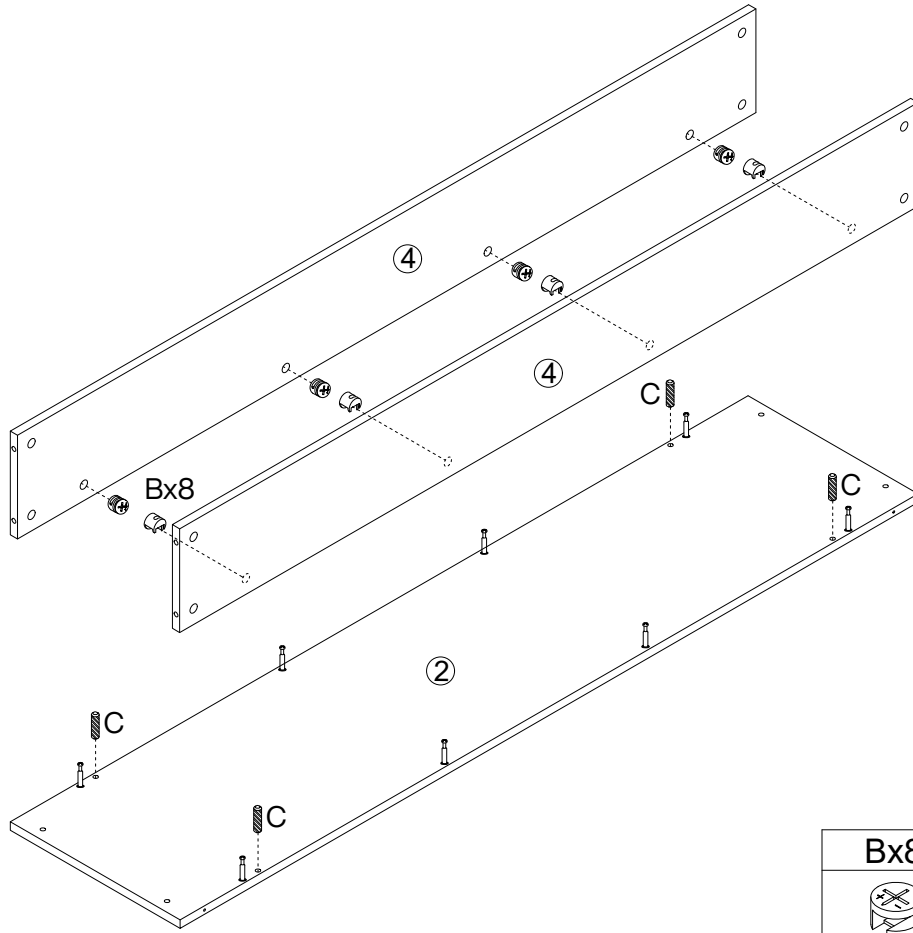
11



Bx8	Cx4
	
Ø15X12mm	Ø8X30mm

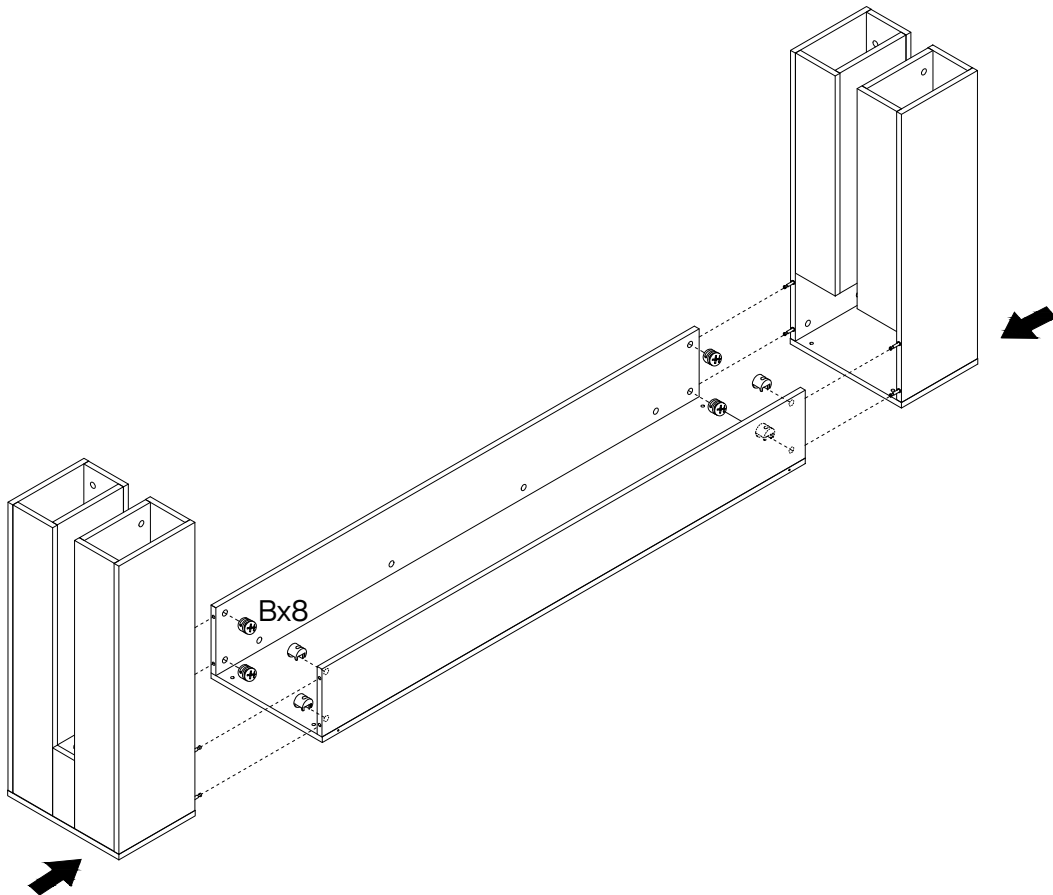

12

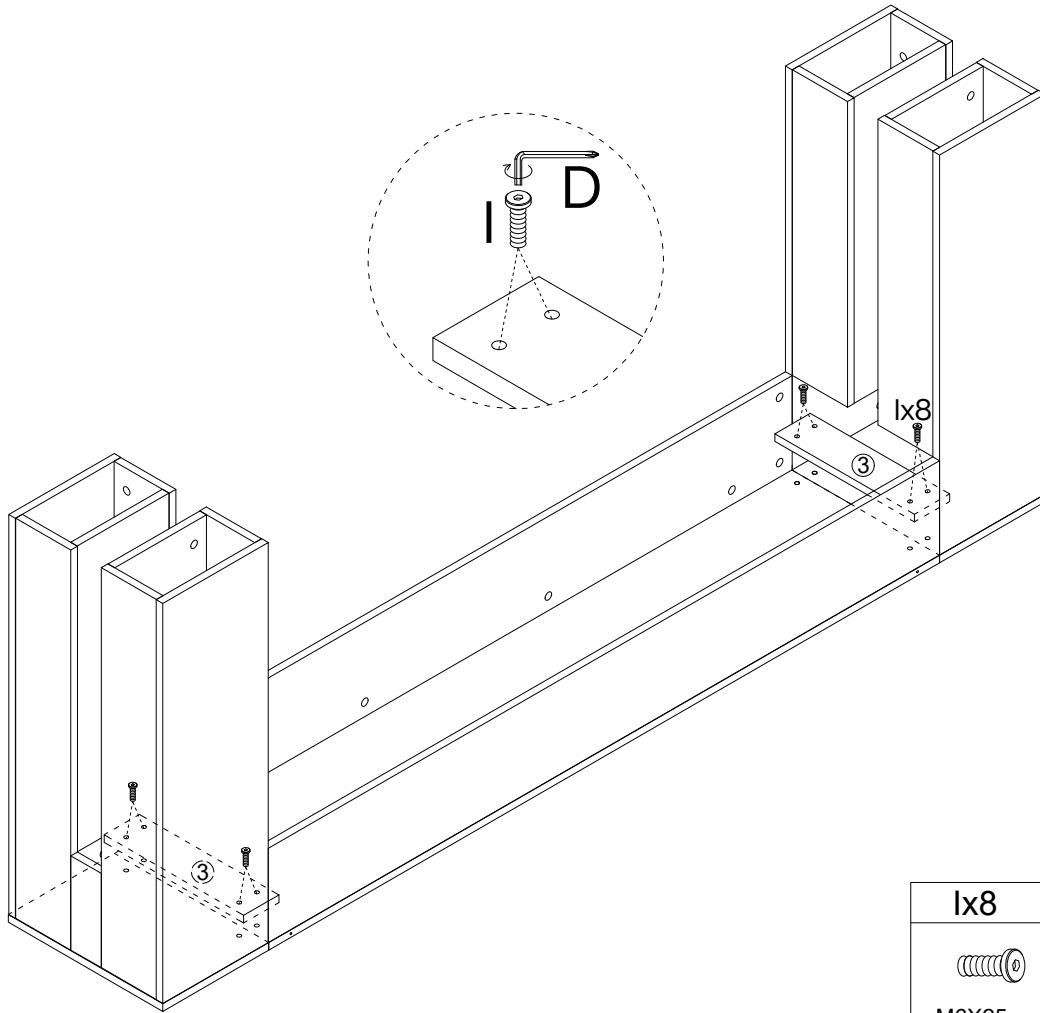

Bx8

Ø15X12mm



13

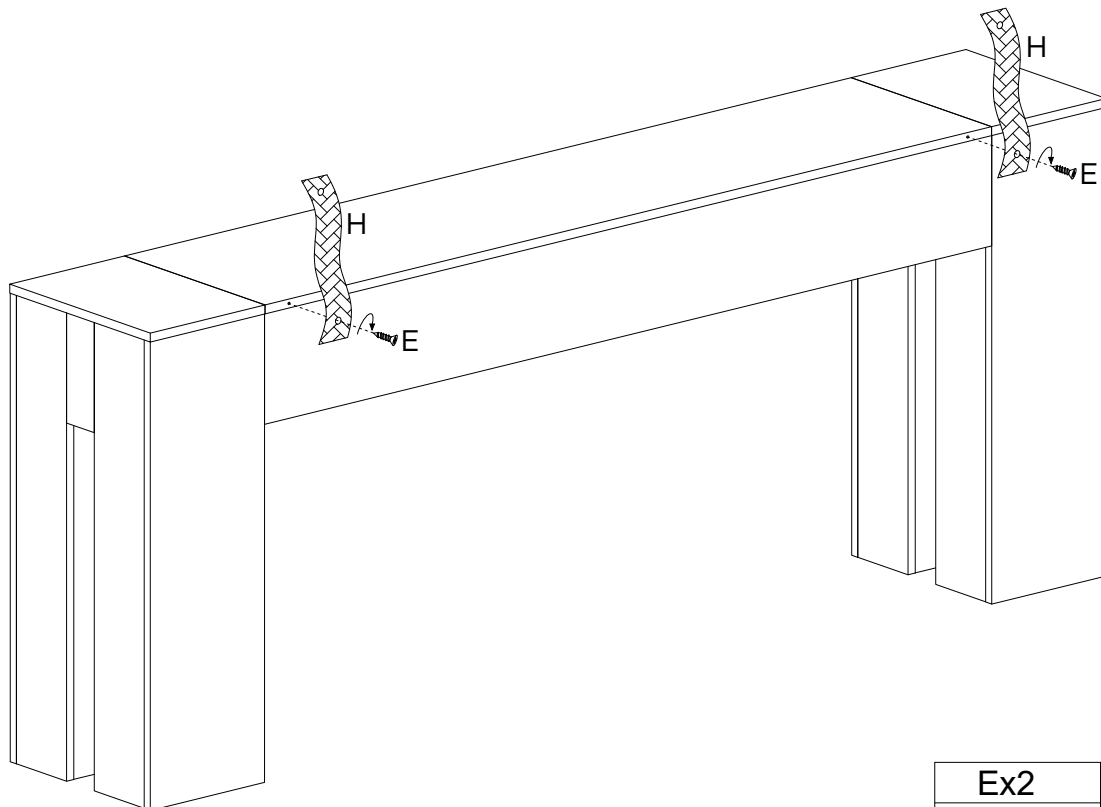

Ix8	Dx1
	
M6X25mm	M4X64mm

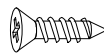

14

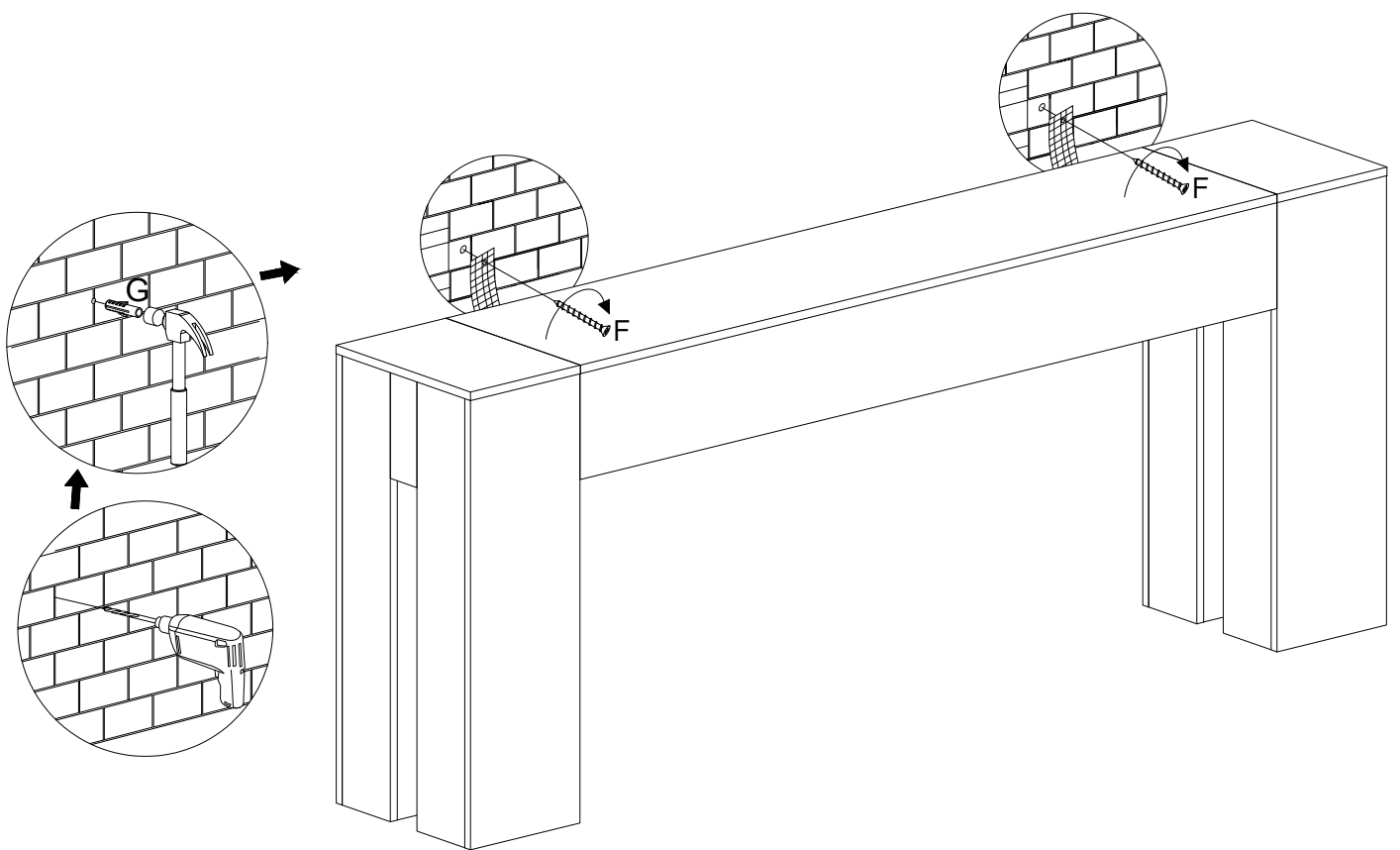

Ex2	Hx2
	
Ø3.5X14mm	155X20mm

15



Fx2	Gx2
	
Ø4X35mm	H Ø8X40mm