

ASSEMBLY INSTRUCTIONS

ASSEMBLY TIPS:

1. Remove hardware from box and sort by size.
2. Please check to see that all hardware and parts are present prior to start of assembly.
3. Please follow attached instructions in the same sequence as numbered to assure fast & easy assembly.



Warning !

1. Don't attempt to repair or modify parts that are broken or defective . Please contact the store immediately.
2. This product is for home use only and not intended for commercial establishment.

PARTS IDENTIFICATION

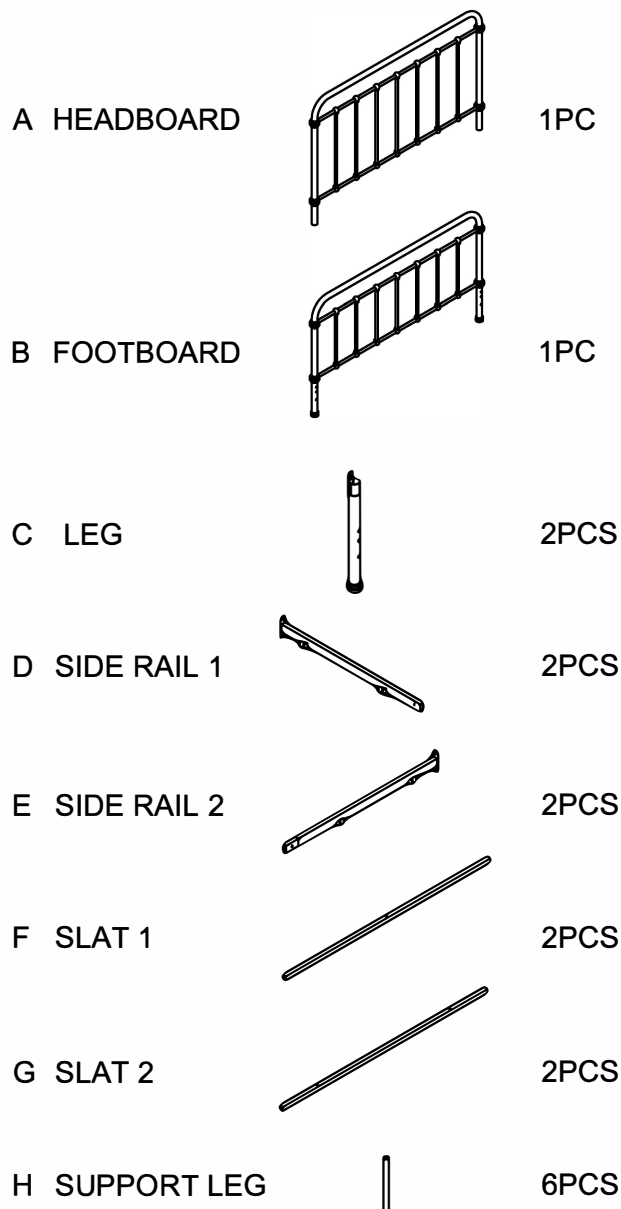



Z HARDWARE LIST:

NO	DESCRIPTION	FIGURE	Q`TY
1	BOLT 1/4"X2"		4pcs
2	BOLT 1/4"X1-3/4"		6pcs
3	BOLT 1/4"X7/8"		4pcs
4	BOLT 1/4"X5/8"		16pcs
5	WASHER ϕ 16MM		30pcs
6	HEX. NUT		4pcs
7	ALLEN WRENCH		1pc
8	OPEN END WRENCH		1pc

ASSEMBLY



Do not fully tighten all bolts until assembly is complete. This will help all parts to assemble properly.

Step 1: Align and attach the leg (C) to the headboard (A) using the bolt (4) and washer (5), tighten with allen wrench. As shown on the drawing.

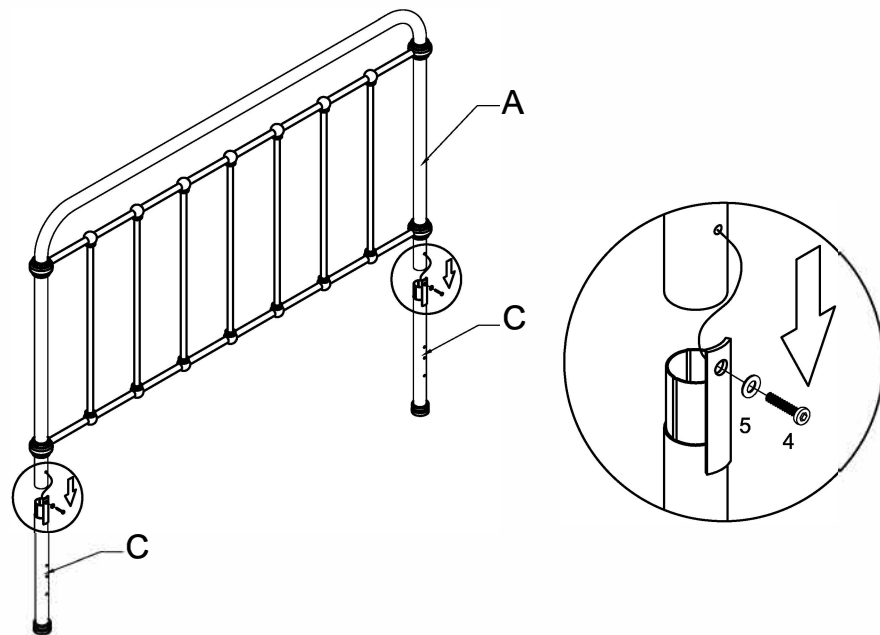
4		2PCS
5		2PCS
7		



Step 2: Align the side rail 1 (D) and side rail 2 (E), then attach them together using the bolt (4), washer (5), tighten with allen wrench. As shown on the drawing.

4		6PCS
5		6PCS
7		

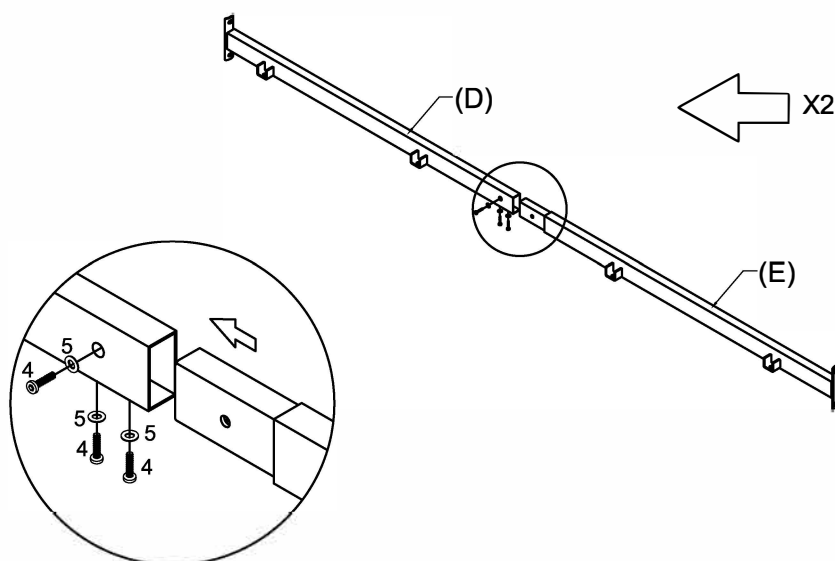

Step 3: Align the assembled side rail, and attach them to headboard (A) and footboard (B) using bolt (1)&(3), washer (5), hex.nut (6), tighten with wrench (7)&(8). As shown on the drawing.

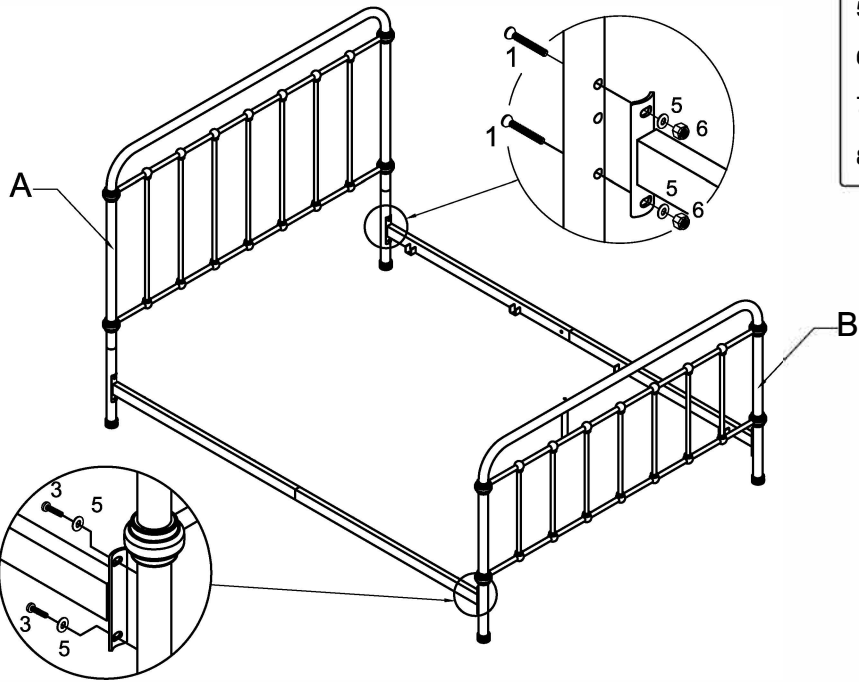

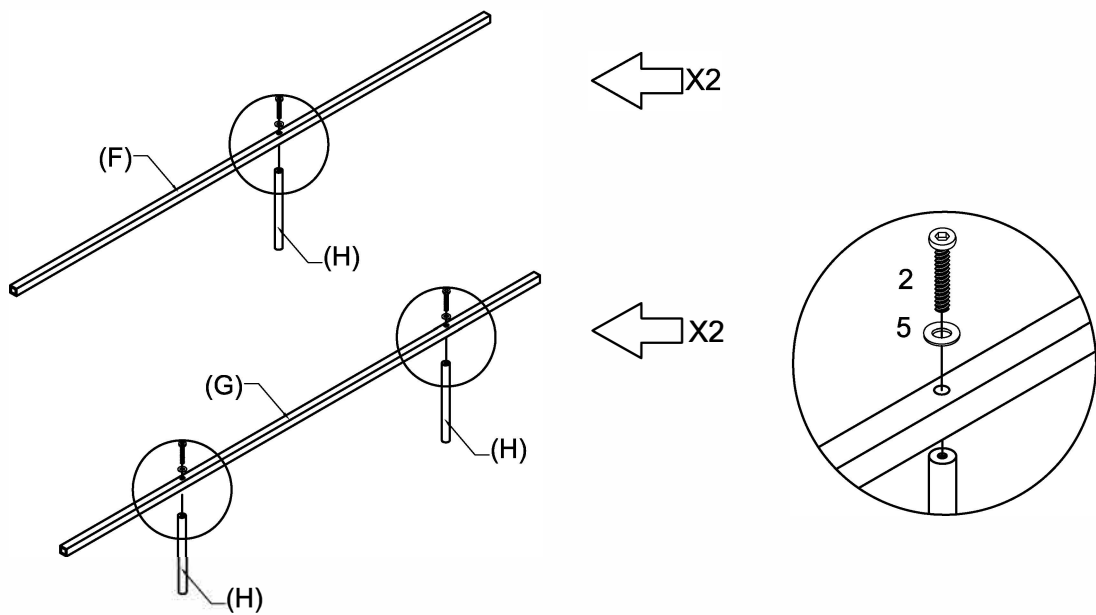

1		4PCS
3		4PCS
5		8PCS
6		4PCS
7		
8		

Step 4: Align the support leg (H) and slat 1 (F), slat 2 (G) then attach them together, bolt (2), and washer (5), finally, tighten with allen wrench. As shown on the drawing.



2		6PCS
5		6PCS
7		

Step 5: Attach the assembled slats with support leg to side rails, using bolt (4) and washer (5), finally tighten with allen wrench. As shown on the drawing.

4		8PCS
5		8PCS
7		

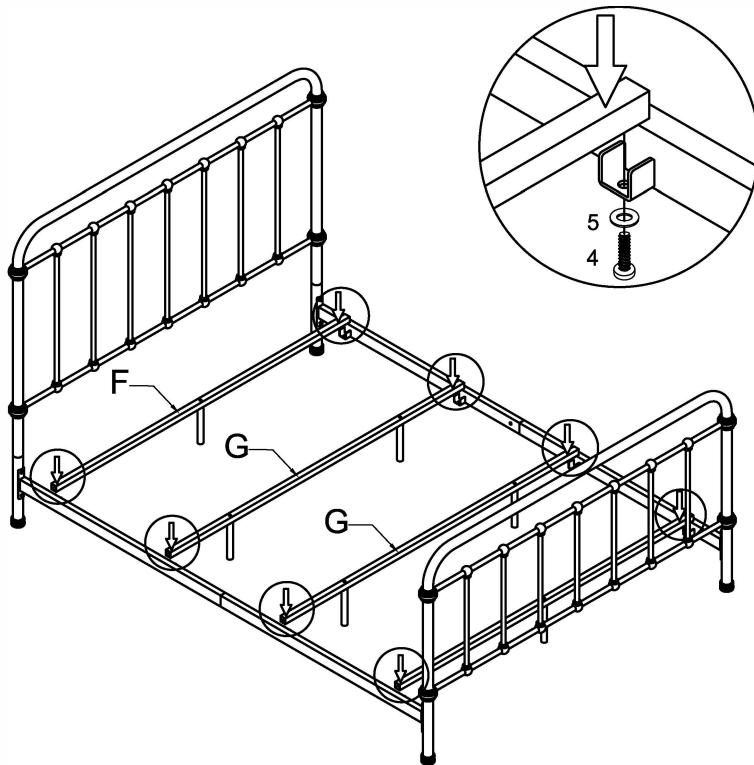

Step 6: Completed

