

# ASSEMBLY INSTRUCTIONS

VERSION [1]

## Ava Clipped Edge Nailhead Platform Bed-QN

Avoid using sharp objects such as a knife to cut open packing as you may accidentally damage the upholstery.

### HARDWARE LIST

ITEM	DESCRIPTION	SKETCH	QUANTITY
1	JCBB M8 X 20		8
2	JCBC M6 X 30		20
3	JCBC M6 X 50		6
4	JCBC M6 X 60		4
5	ALLEN KEY 65MM		1
6	ALLEN KEY 70MM		1
7	CSK SCREW 32MM		24
8	SPRING WASHERS		6
9	FLAT WASHERS		8
10	ADJUSTER		4

### PART LIST

ITEM	DESCRIPTION	SKETCH	QUANTITY
A	HEADBOARD		1
B	FOOTBOARD		1
C	SIDE RAIL		4
D	HEADBOARD LEG		2
E	FOOTBOARD LEG		2
F	SIDE RAIL LEGS		2
G	CENTER RAIL		2
H	12 SLAT		2
I	SUPPORT LEGS		4
J	SIDE RAIL SUPPORT WOOD		4

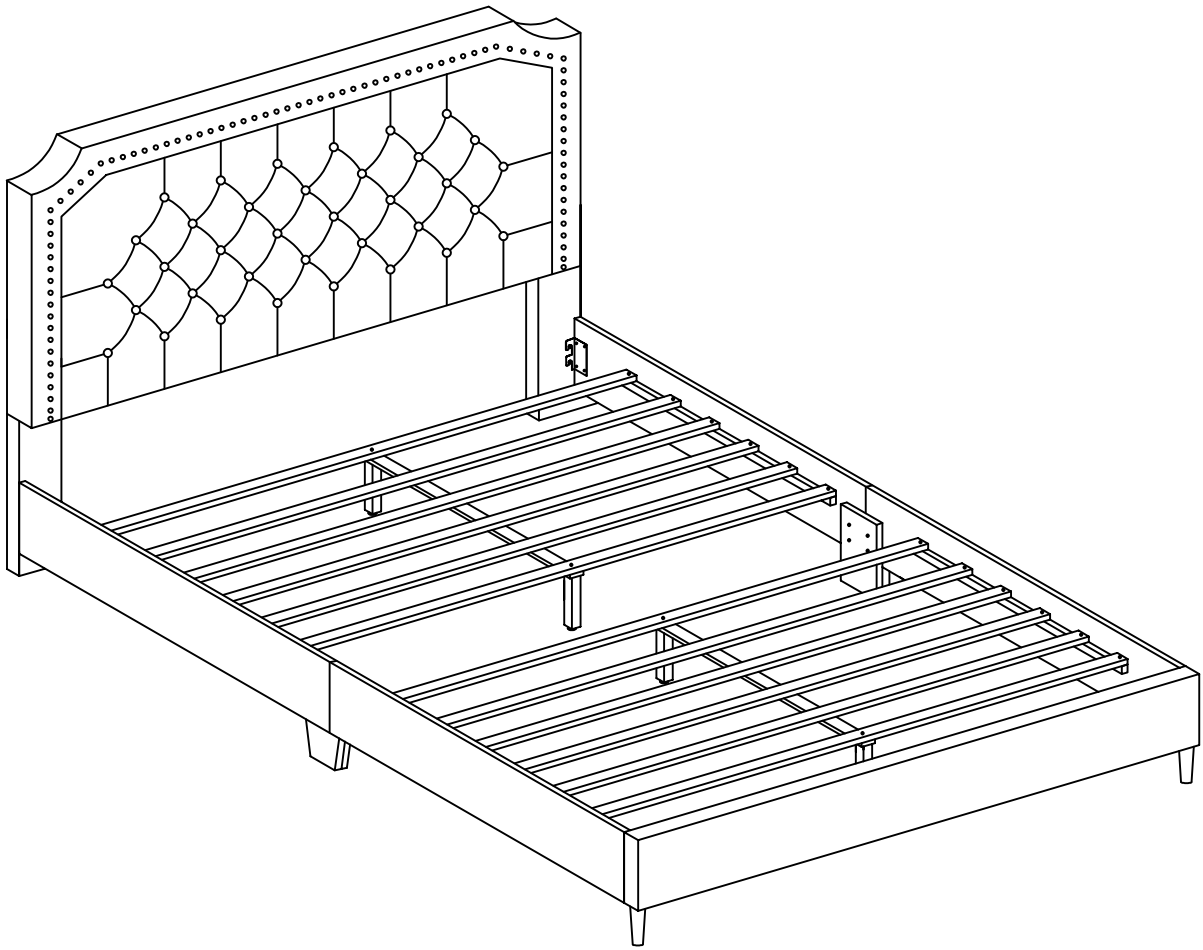

# ASSEMBLY INSTRUCTIONS

**Do not fully tighten bolt until assembly is complete.**

## STEP 1

Unzip the black non-woven fabric on the back of headboard and take out all the parts out.

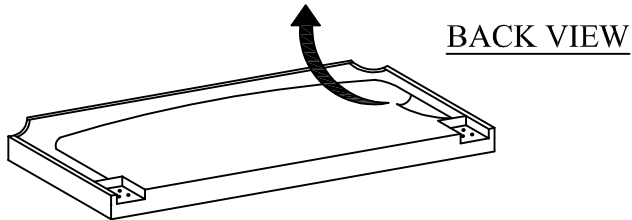

**Attention: Zip the black non-woven fabric after take out the parts !!**

## STEP 2

Fix the headboard (A) and footboard (B) with legs (D,E) as shown.

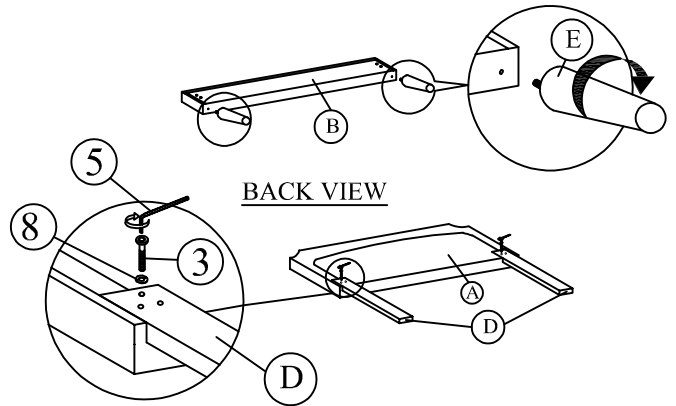

## STEP 3

Attach the ICBB Bolt (1) to the headboard (A) and footboard (B).

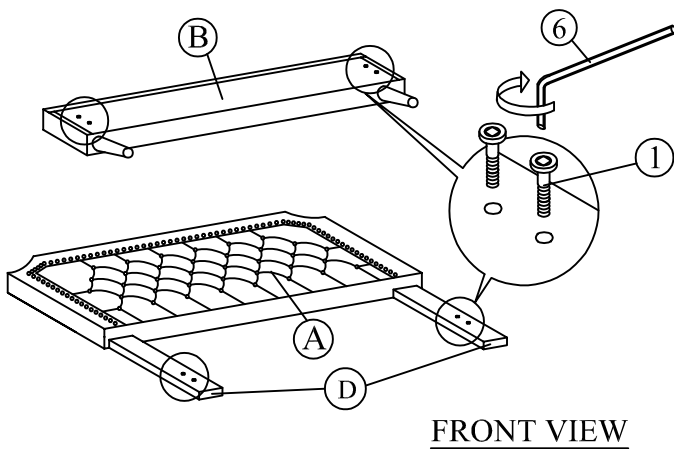

## STEP 4

Attach the side rail support wood (I) to the side rail (C).

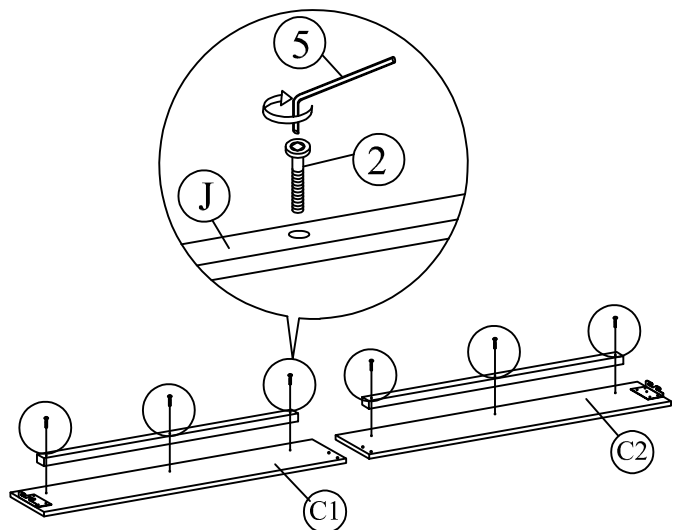

**STEP 5**

Attach the side rail leg (F) to the side rail (C).

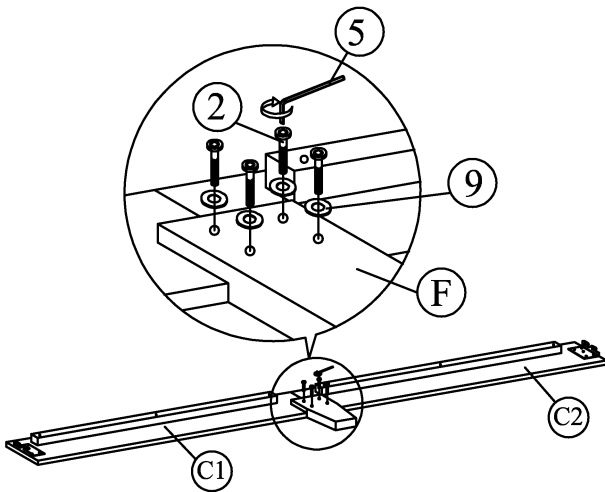

**STEP 6**

Attach side rail (C) to headboard (A) and footboard (B) by pushing the bracket down to fit it.

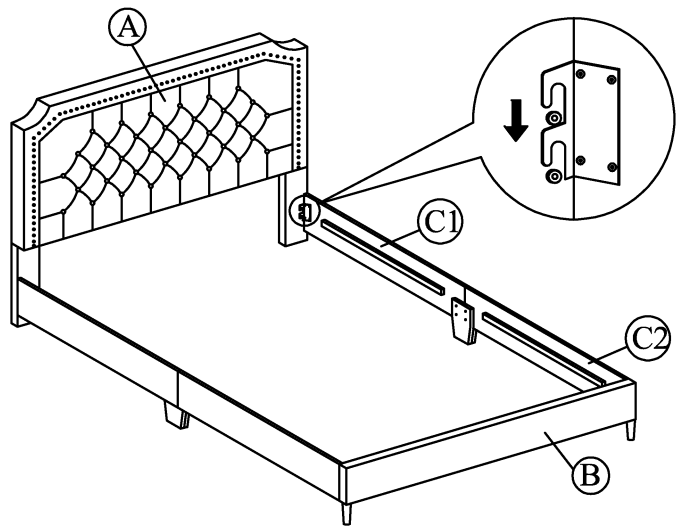

**STEP 7**

Attach the support legs (J) to the slats (H) and center rail (G).

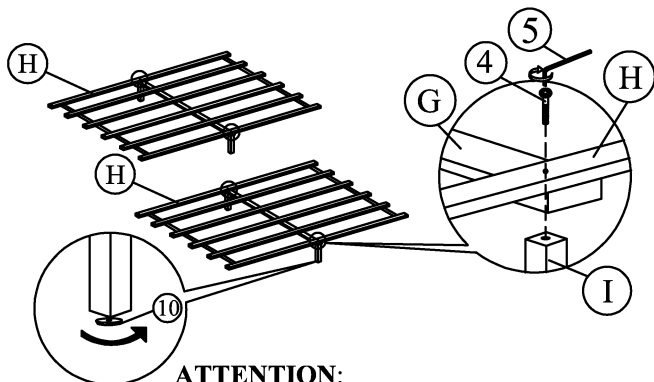

**ATTENTION:**  
Please keep the adjuster around 5 to 8 mm distant away from the floor.

**STEP 8**

Tighten the 4 Corner with Allen Key (6). Install the bed slats to side rail. Tighten the slats with CSK screw. The distance of the slats should be sufficient to obtain desirable bed stability.

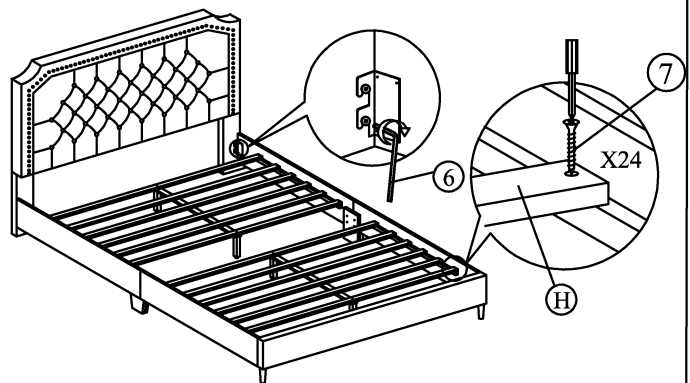

**CLEANING INSTRUCTIONS:** Clean with a Soft cloth, brush, or lightly vacuum

**ADULT ASSEMBLY REQUIRED**

If you are missing any parts or have any questions regarding assembly, do not return this item to the retailers store. Please call our toll-free, customer service number and have this assembly manual open to the parts list ready to provide the model name, number and part name or number.



# ASSEMBLY INSTRUCTIONS

VERSION [1]

## Ava Clipped Edge Nailhead Platform Bed-EK

Avoid using sharp objects such as a knife to cut open packing as you may accidentally damage the upholstery.

### HARDWARE LIST

ITEM	DESCRIPTION	SKETCH	QUANTITY
1	JCBB M8 X 20		8
2	JCBC M6 X 30		20
3	JCBC M6 X 50		6
4	JCBC M6 X 60		8
5	ALLEN KEY 65MM		1
6	ALLEN KEY 70MM		1
7	CSK SCREW 32MM		24
8	SPRING WASHERS		6
9	FLAT WASHERS		8
10	ADJUSTER		8

### PART LIST

ITEM	DESCRIPTION	SKETCH	QUANTITY
A	HEADBOARD		1
B	FOOTBOARD		1
C	SIDE RAIL		4
D	HEADBOARD LEG		2
E	FOOTBOARD LEG		2
F	SIDE RAIL LEGS		2
G	CENTER RAIL		4
H	12 SLAT		2
I	SUPPORT LEGS		8
J	SIDE RAIL SUPPORT WOOD		4

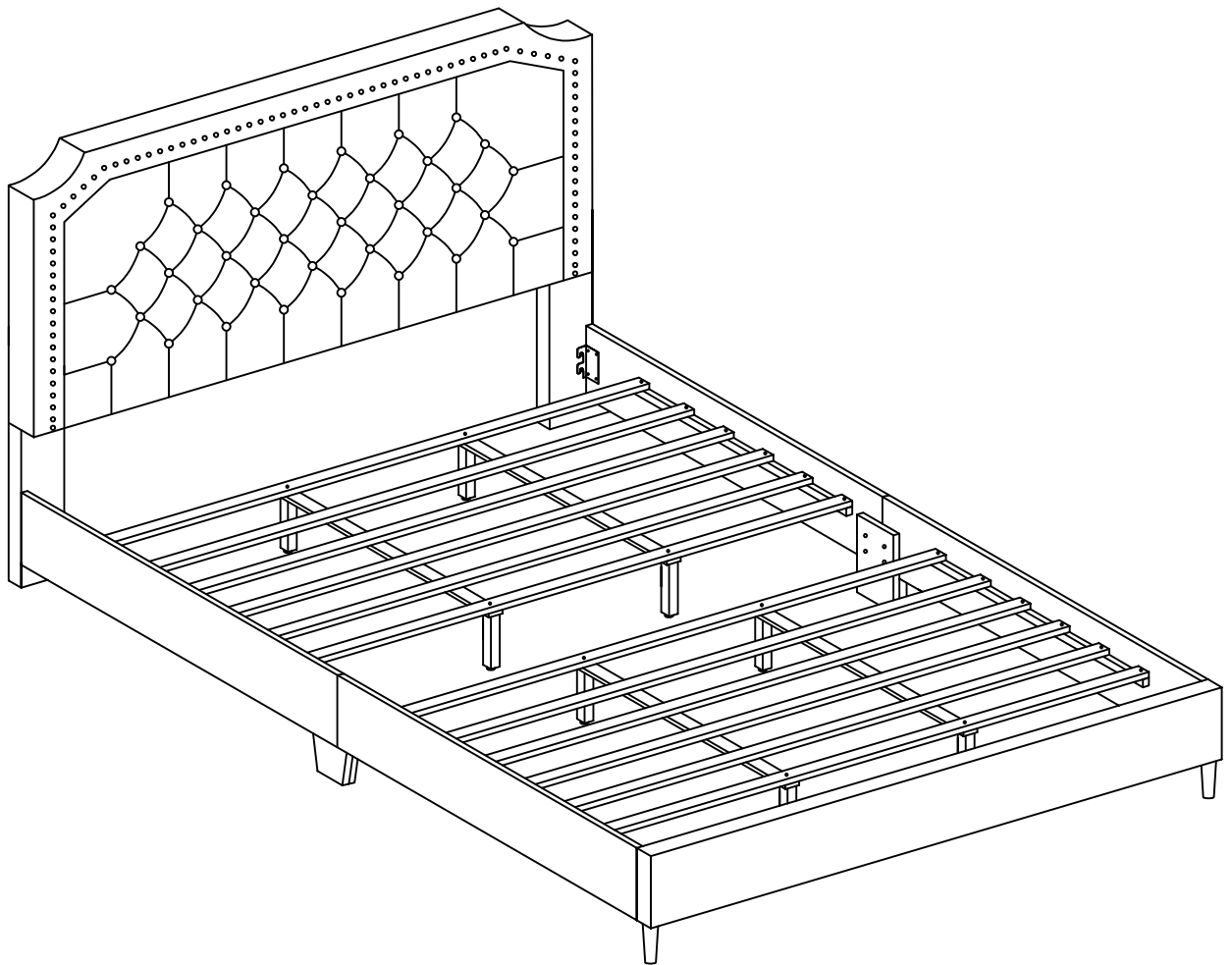

# ASSEMBLY INSTRUCTIONS

**Do not fully tighten bolt until assembly is complete.**

## STEP 1

Unzip the black non-woven fabric on the back of headboard and take out all the parts out.

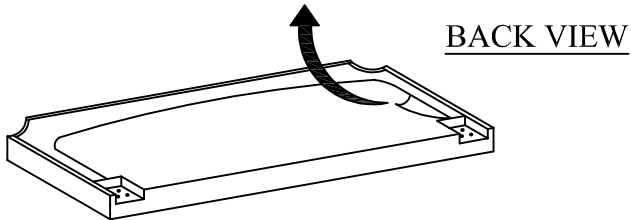

**Attention: Zip the black non-woven fabric after take out the parts !!**

## STEP 2

Fix the headboard (A) and footboard (B) with legs (D,E) as shown.

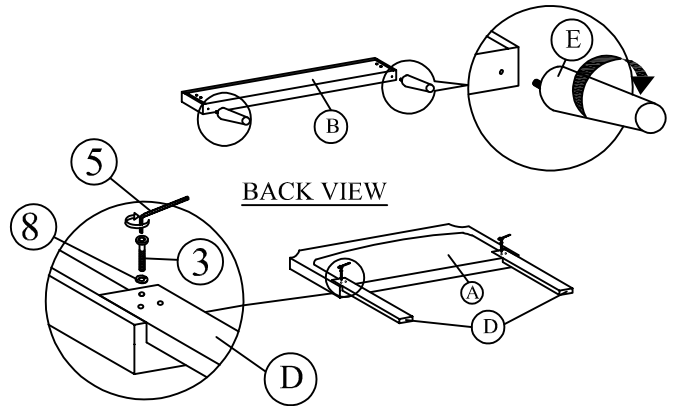

## STEP 3

Attach the ICBB Bolt (1) to the headboard (A) and footboard (B).

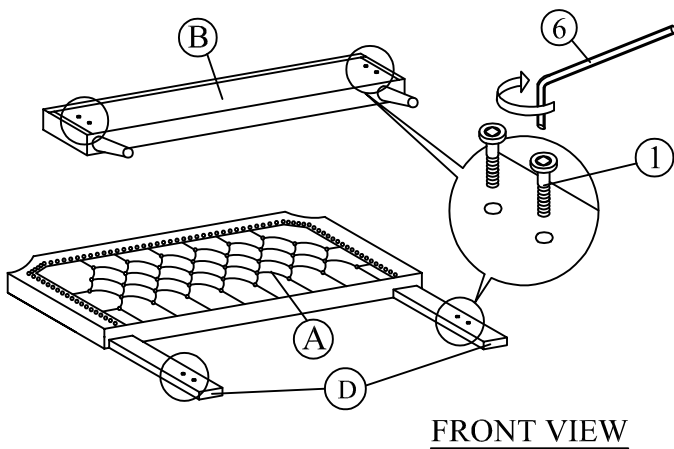

## STEP 4

Attach the side rail support wood (I) to the side rail (C).

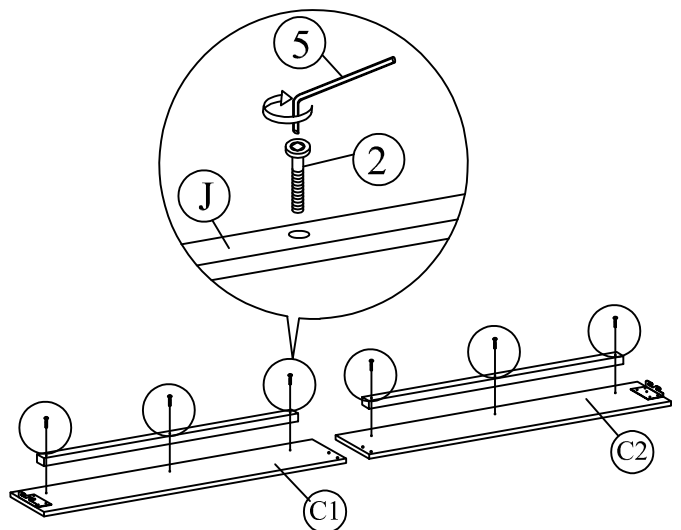

**STEP 5**

Attach the side rail leg (F) to the side rail (C).

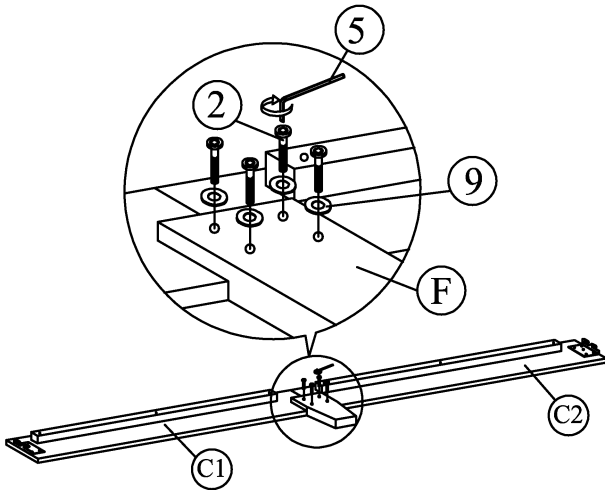

**STEP 6**

Attach side rail (C) to headboard (A) and footboard (B) by pushing the bracket down to fit it.

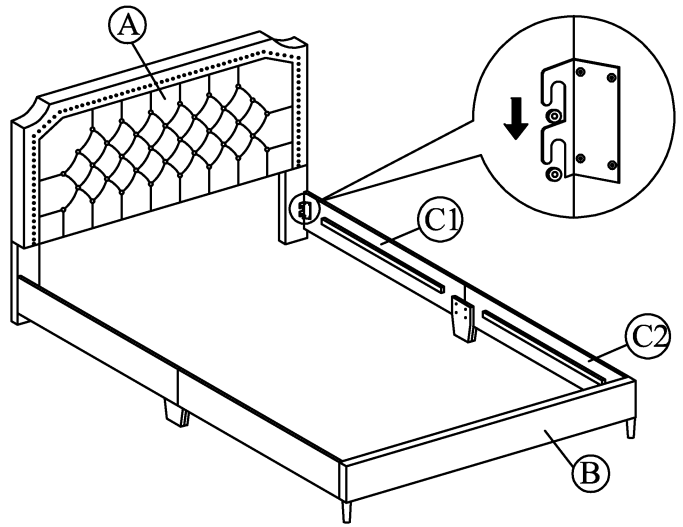

**STEP 7**

Attach the support legs (J) to the slats (H) and center rail (G).

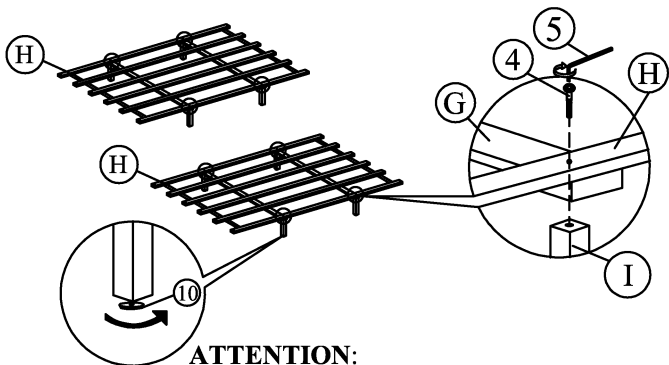

**ATTENTION:**  
Please keep the adjuster around 5 to 8 mm distant away from the floor.

**STEP 8**

Tighten the 4 Corner with Allen Key (6). Install the bed slats to side rail. Tighten the slats with CSK screw. The distance of the slats should be sufficient to obtain desirable bed stability.

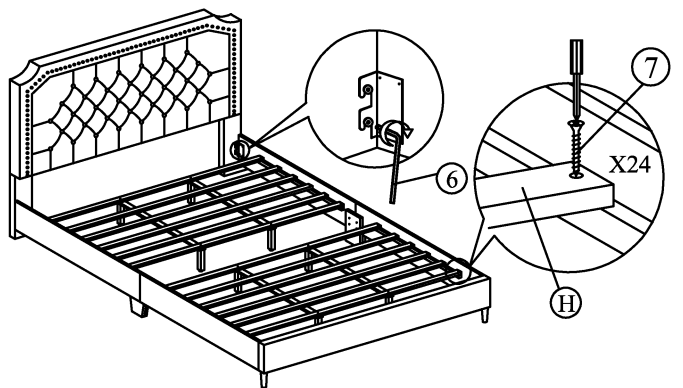

**CLEANING INSTRUCTIONS:** Clean with a Soft cloth, brush, or lightly vacuum

**ADULT ASSEMBLY REQUIRED**

If you are missing any parts or have any questions regarding assembly, do not return this item to the retailers store. Please call our toll-free, customer service number and have this assembly manual open to the parts list ready to provide the model name, number and part name or number.

