

# Massage Chair User Manual

## Massage Chair User Manual

# CONTENTS

■ Safety Instructions	02
■ Operating precautions	07
■ Setting up	09
■ Names and Functions of Parts	12
■ Before starting massage	
■ How to use the chair	02
■ Specifications	02

Thanks for choosing OOTORI massage chair. This operating manual contains important information about how to use the chair safely and correctly. Be sure that you have read all safety instructions thoroughly before using your chair. Keep this manual nearby so that you can refer to it any time.

If you have any problem, please feel free to contact us.

# Safety Instructions

## CAUTION: To avoid the risk of injury

1. Persons with any of the conditions listed below are not suitable to use the chair :  
Osteoporosis patient.  
People with heart disease including embedded pacemaker or other medical electronic device inside the body.  
For pregnant women or people with health issues, please consult doctor before use.  
Patient with a high fever forbid to use this machine.  
Perceptual disabilities patients forbid to use this machine.  
People over 80 years old forbid to use this machine.  
Kids and the drunk people are not allowed to use this machine.  
Please don't sleep in the chair.  
Don't use the chair when your body is wet
2. This unit should not be used by children. Remove the key when not in use and store out of reach of children.
3. Do not insert your hands, fingers, feet or head into the spaces following spaces:  
Between the backrest and seat or armrest  
Between the leg rest and seat or armrest  
Between the seat and armrest  
Between the back cover and leg cover  
Back of the leg rest
4. Do not use the unit against bare skin. While thin clothing may increase effectiveness, exposing the skin directly to the massager may irritate the skin.  
Do not use the unit while wearing anything hard on your head like a hair accessory, etc. Do not use the unit for massaging the head, abdomen, front neck, elbows or knees.
5. Do not use excessively strong massage action on the back of the neck.  
Do not stretch the back muscles for more than approximately 16 minutes at a time. To avoid overstretching the muscles

which may result in discomfort, do not use the unit for more than 5 minutes when first using it. You can gradually increase the duration and strength of the massage as you become used to it.

6. Stop using the unit immediately should you experience any discomfort and consult the physician.
7. Do not go to sleep while using the unit. Do not use the unit after drinking alcohol.
8. When the seat back is in a reclined position, do not sit on it or sit with your legs resting on the headrest.  
Do not sit on the leg rest as the unit may fall over.
9. Do not allow children or pets to play on or around the unit, especially during operation.
10. Do not unplug the unit or turn it off during operation. Unplug the unit immediately if there is a power outage.
11. Be sure to start on the gentle massage program if using the massager for the first time.
12. Do not allow children to play on this mechanized furniture or operate the mechanism. Leg rest folds down on closing so that a child could possibly be injured. Always leave in an upright and closed position. Keep hands and feet clear of mechanism. Only the occupant should operate it.
13. Remove hard objects, such as false fingernails, wristwatches or rings, when massaging hands or arms. Empty pockets of hard objects when massaging the area of the seat or thighs.
14. People with any of the conditions listed below should not use the Hip stretch
  - People suffering from acute lumbago, spinal disc herniation, or misalignment of the vertebrae
  - People with hip joint problems such as hip osteoarthritis
  - People with osteoporosis
  - People who felt numbness or listlessness in the legs It may worsen the symptoms. Always return the leg rest to its original position before moving the unit.Failure to observe this precaution may result in injury due to

the leg rest returning to its original position when the unit is being moved.

Store the attachment screws out of reach of children.

Accidental ingestion may occur.

Do not stand, jump on, or place objects on the seat until the air is completely extracted for the air massage.

Do not hold the sole massage section when moving the unit.

Doing so may result in the section sliding as you move the unit, causing injuries.

Do not drag or push the unit in an installed state.

Protect your floor (place a mat or similar) when moving the unit on its castors to avoid damage to your floor.

If you have not used the unit for a while, carefully read this operating instructions again and check that the unit is operating normally before use.

Failure to do so may result in accident or injury.

Do not use at the same time as another medical device. Doing so may cause an accident or deteriorated health.

Do not allow children to use the controller holder fixing screw.

Failure to do so may result in an accident or the child accidentally swallowing the key or screw.

## **DANGER:** **To reduce the risk of electric shock**

1. Always unplug this unit from the electrical outlet immediately after using.
2. Always unplug this unit from the electrical outlet immediately before cleaning.

## **WARNING:**

### **To reduce the risk of burns, fire, electric shock, or injury to persons:**

1. Fully insert the power plug to reduce the risk of short-circuit and fire.
2. The unit should never be left unattended when plugged in. Always unplug the unit when not in use.
3. The unit is not to be used by people who cannot move or communicate on their own.
4. Only use the unit for the purpose described in these instructions.
5. Do not stand on the unit.
6. Do not use any accessories other than those recommended by the manufacturer.
7. Always return the seat to the upright position and make sure the leg rest is completely retracted. Be careful that nothing is obstructing the leg rest while retracting. Keep children away from the leg rest.
8. Never operate the unit if it has a damaged power cord or plug. Return the unit to the nearest authorized service center if it is not working properly, if it has been dropped or damaged, or if it has been immersed in water.
9. Keep power cords away from heated surfaces. Do not carry the unit by the power cord.
10. Never block the air openings during operation and make sure that all air openings are kept free of lint and hair, etc. Do not drop or insert anything into any of the openings of the unit.
11. Do not use the unit on top of heating appliances, such as electric carpets, etc. Do not operate the unit under blanket or pillow. Excessive heating can occur and cause fire, electric shock, or injury to persons.
12. Do not use the unit in bathrooms or other damp or humid places as this may cause electric shock or cause the unit to malfunction. Do not spill water, etc. onto the controller.

13. Do not use the unit outdoors.
14. Do not use or operate where aerosol spray products are being used or where oxygen is being administered.
15. When unplugging the unit, turn off all controls before removing the plug from power outlet. Do not use the unit with a transformer as this may lead to malfunction or electric shock.
16. Connect this unit to a properly grounded outlet only. See Grounding instructions.
17. Use heated surfaces carefully. May cause serious burns. Do not use over insensitive skin areas or in the presence of poor circulation. The unattended use of heat by children or incapacitated persons may be dangerous.
18. Always raise the comfort cushion to check that the fabric covering the movement area of the massage heads in the backrest has not been ripped before using the unit. Please also check other areas to ensure that the fabric has not been ripped. No matter how small the rip, if you find one then immediately stop using the unit, unplug. Keep long hair away from the unit while in use.
19. Always use sockets and wiring devices at the correct rated value. Use at the specified power supply 120 V, AC.
20. Failure to do so may result in electric shock or fire due to overheating.
21. When Heat massage heads are used, do not let the massage heads touch the same
22. place for a long time. Do not use the Foot Heat massage for a long time. Low-temperature burn may occur.
23. Do not damage the Heat (heater) section. Do not stick pins or needles into the unit.
24. Do not damage with a sharp object. Doing so may damage the internal heater, causing fire or electric shock. Sit on the unit after confirming there is no foreign matter between the parts of the
25. unit. (Confirm that there are no foreign objects stuck in the comfort cushion, leg rest or hand & arm massage section.) Sit down and ensure that the leg rest is properly locked in

place. Failure to observe this precaution may result in accident or injury.

**26.** Sit on the unit after confirming there is no foreign matter between the parts of the unit. (Confirm that there are no foreign objects stuck in the comfort cushion, leg rest or hand & arm massage section.) Sit down and ensure that the leg rest is properly locked in place. Failure to observe this precaution may result in accident or injury.

Periodically remove dust, etc. from the power plug. Failure to do so may result in

**27.** insulation failure due to humidity, etc., which may cause fire. (Remove dust using a dry cloth.

Do not insert or unplug the power plug with wet hands. Doing so may cause electric

**28.** shock.

Do not massage any one point for more than 5 minutes at a time. Excessive massaging

**29.** can overstimulate the muscles and nerves and result in an adverse effect.

After each massage, slide the power switch, which is located on the right side of the

**30.** chair, to the off position and turn its lock switch to the lock position and remove the key and power plug.

Do not attempt to open or disassemble any part of the unit.

Only use an authorized

**31.** Panasonic servicer to fix your unit.

If the massager functions abnormally, immediately turn off the power and have the

**32.** massager checked by an authorized service center.

## **OPERATING PRECAUTIONS**

### **CAUTION: To avoid damaging the chair, follow these precautions**

**1.** Use the chair only when it is placed on an even, flat surface. Failure to observe this may result in upset.

**2.** Do not sit on or drop the controller.

**3.** Do not pull the controller cord or the power cord. Be careful not to catch the cord of the controller between the armrest and the chair back.

**4.** Do not treat the chair roughly, such as turning the chair on its side, turning the chair over or standing on it.

**5.** Do not treat the covering roughly.

**6.** Keep sharp or pointed objects away from the covering of the chair.

**7.** Be careful not to drop lit ashes, lit cigarettes or matches on the chair.

**8.** Exposure to direct sunlight can cause fading or a change in color of the covering.

**9.** Do not repeatedly operate any switch at short intervals. Such action may cause the switch to malfunction.

**10.** Some noise may be heard coming from the massager while in use. This is due to the structure of the massager and is normal.

**11.** Make sure there are no obstacles behind the chair before reclining it. If the back hits a wall or pillar, the chair may malfunction. Be sure to have ample space behind the chair. Recline the chair slowly in order to avoid contact with an obstacle.

**12.** When excessive pressure is applied to the massage heads, they may stop moving for safety.

**13.** When moving the heads up from the lowered position, one's body weight may stop the heads' movement. In such a case, slightly raise your body and allow the massage heads to move up.

**14.** Do not sit on the chair with wet body or hair.

**15.** The unit must not be used in "wet rooms" (sauna, swimming pool) or outdoors.

**16.** Always hold the power plug, not the power cord, when unplugging it from a socket.

Failure to observe this precaution may result in electric shock or short-circuit.

## GROUNDING INSTRUCTIONS

This product must be grounded. If it should malfunction or break down, grounding provides a path of least resistance for electric current to reduce the risk of electric shock. This product is equipped with a cord having an equipment-grounding conductor and a grounding plug. The plug must be plugged into an appropriate outlet that is properly installed and grounded in accordance with all local codes and ordinances.

### DANGER

Improper grounding may lead to electric shock. Check with an authorized service center if you are in doubt as to whether the unit is properly grounded. In case the supplied plug does not match the outlet, do not attempt to modify the plug. Please contact a qualified electrician to have a proper outlet installed.

This unit has a grounding plug. Make sure that the unit is connected to a power to a power outlet with the same configuration as the plug. Do not use an adaptor with this unit.

This unit has a grounding plug. Make sure that the unit is connected to a power to a power outlet with the same configuration as the plug. Do not use an adaptor with this unit.

## Before use

### About setting up

- Ensure adequate space around the unit and place it on a flat surface. Avoid placing the unit exposed to direct sunlight or near any heating device or in other locations with a high temperature to avoid discoloration or deterioration on the surface of the holster or back pad.
- It is recommended to place a carpet or soft mat underneath the unit to avoid damaging the floor.
- The size of such carpet or mat should be large enough to cover the surface where the unit and the footrest may come in contact with the floor.
- With the backrest reclined backward, the footrest goes up. To avoid collision with any surrounding objects, a clearance of at least 5.9" at the front and at least 9.8" at the back should be reserved around the unit.

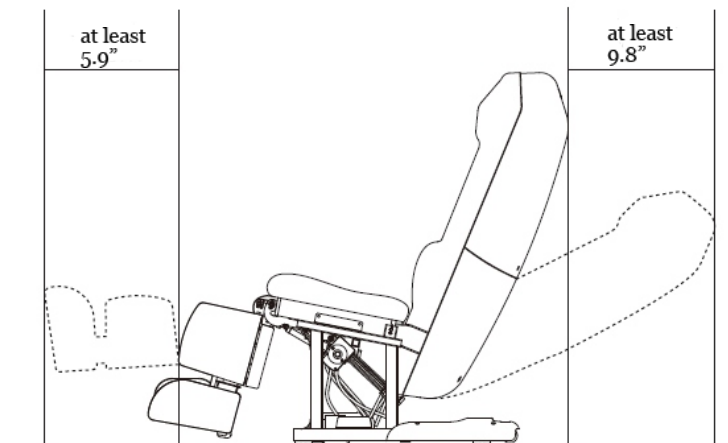

## Assembly

1. Take out the main unit and all of the accessories from the box for installation.
2. Take out the massage chair and place it on flat ground, press down the backrest of the main unit after raised up it at about 43.3°, it will be locked when a reminding sound “Ka” is heard.



3. Embed the bolt (A) on the side of the main unit in the groove (B) of the armrest.



4. Connect the tubes of the armrest with the tubes of the main unit, blue with blue, yellow with yellow, green with green.



5. Fasten the armrests onto seat with screws.



6. Attach the chair pad to the headrest with the velcro and zip up.



## Moving the chair

As the following illustration, push the back rest downwards and tilt chair on to its wheels at 45° angle. Slowly push and maneuver the massage chair to desired location. Lower massage chair slowly and smoothly until it is fully flat on the ground.

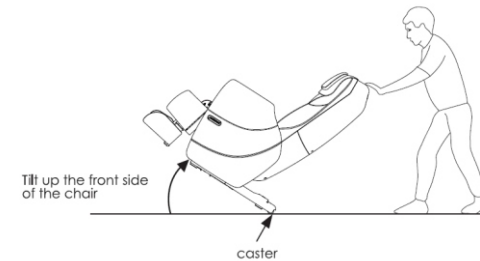

## Names and Functions of Parts

### Main Unit



## Remote Controller



## Before starting using the chair

### 1. Connect the power cord plug with the receptacle.

Check if the power cord, remote controller cord or power plug is damaged and check whether there is any hair or dust on the plug

### 2. Turn on the power switch.

The power switch is located at the lower right side of the base. Confirm that the switch is in the I (ON) position (When the power is on, the power indicator lights up).

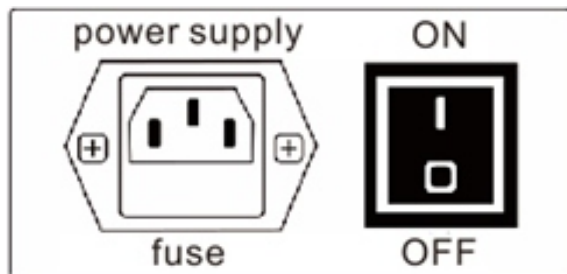

### 3. Make sure to check the surrounding conditions.

Make sure that there is no person, pet or object behind the chair, in front of and below the footrest.

### 4. Check the condition of the massage chair.

1) hold up the back pad and check for any tear in the backrest cloth as well as in any other parts.

Should there be any tear, no matter how small it is, stop using the unit immediately, unplug the power cord and have the unit repaired.

2) Check whether the power cord, remote controller cord or any other object is pinched in the main body.



## How to use the chair

Button	Function
ON/OFF	Press the power button to turn on the massage chair. Press again to power off, the the massage chair will return to default upright position. The default time is 15 minutes.
Auto	Press this button to select one auto mode, there are 3 auto modes to choose from: Full Body Massage, Partial Massage and Aid Sleep Massage.
Location	Under manual mode, you can use the button to fix the massage points with the buttons Upper/Lower
Mode	Press this button to activate the manual mode.
Timing	Timing: 5-20 minutes adjustable, 5 minutes as a adjustable unit, default working time: 15 minutes.
Heating	Press this button to switch on/off the heating mode.
Buttocks	Press this button to massage buttocks.
Calves	Press this button to massage calves.
Arms	Press this button to massage arms.
Vibration	Press this button switch on/off vibration
Speed	Press this buttons to adjust the speed.
Air pressure	Press this button to switch on/off the air pressure.
Strength	Press this buttons to adjust the strength.
Back upward	Press and keep holding the button to raise the backrest.
Back downward	Press and keep holding the button to lower the backrest.

## Troubleshooting

Problem	Solution
<ul style="list-style-type: none"> <li>*The rollers and the backrest pad make frictional sound.</li> <li>*Motor sound is clearly hearable during operation.</li> <li>*Loud sound is given when tapping and kneading massage is performed</li> </ul>	<ul style="list-style-type: none"> <li>*This is the sound produced by mechanical structure instead of failure of internal components.</li> <li>*This may occur during normal operation.</li> </ul>
<ul style="list-style-type: none"> <li>*Massage is suddenly stopped and the massage rollers return to their original position.</li> </ul>	<p>The preset auto-timing has been reached. In order to avoid the massage armchair from causing accident due to overheat, this chair is equippedwith overheat reboot protection equipment.</p> <p>If the chair stops and fails to restart as a result of overheat, turn off the main power switch for at least 30 minutes in order to prevent it from suddenly starting after components are cooled down.</p> <p>The power button was pressed accidentally.</p>
<ul style="list-style-type: none"> <li>*The remote controller does not work.</li> </ul>	<ul style="list-style-type: none"> <li>*Check the power plug and ensure that it is indeed plugged into the socket.</li> <li>*Check whether the lines on the back of the massage chair are properly connected.</li> <li>*Confirm the main power switch is turned on.</li> </ul>
<ul style="list-style-type: none"> <li>*The power cord and plug are excessively hot.</li> </ul>	<ul style="list-style-type: none"> <li>* Stop using immediately and contact the service centre.</li> </ul>
<ul style="list-style-type: none"> <li>*The massage stops in the process.</li> </ul>	<ul style="list-style-type: none"> <li>* Turn off the main switch on the back of the chair and turn on 5 seconds later. If the same problem is occurred again, please turn off the main switch, unplug the power cord and contact the customer service.</li> </ul>

## Specifications

Description	Specifications
Product Name	Massage Chair
Rated Voltage	120V
Rated Frequency	60HZ
Rated Power Consumption	120W
Dimension (LxWxH) Inches	60.02 x 30.71 x 43.31 inches
Net Weight (LBS)	176.36 lbs
Gross Weight (LBS)	233.68 lbs
Fit up to	6.3 Feet / 400 lbs