

BRIGHTON OTTOMAN BED ASSEMBLY INSTRUCTIONS

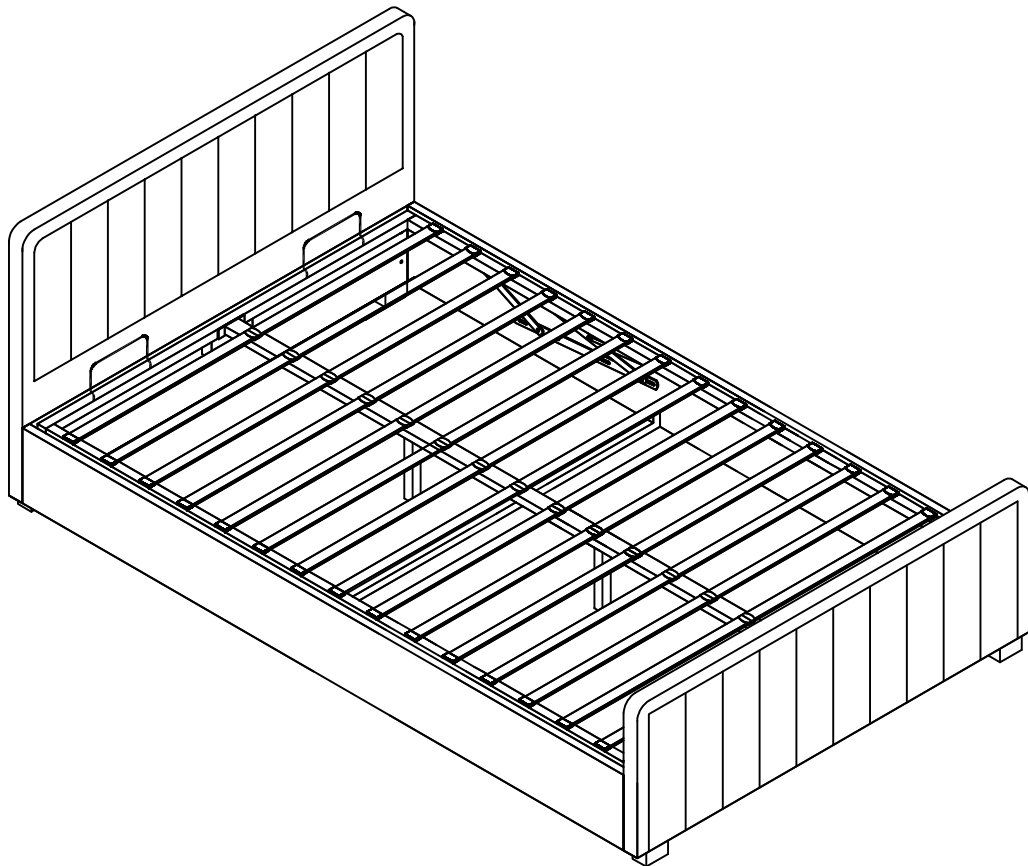

**BRIGHTON OTTOMAN BED IS FOR DOMESTIC USE
AND STRICTLY NOT FOR CONTRACT USE.**

PART LIST

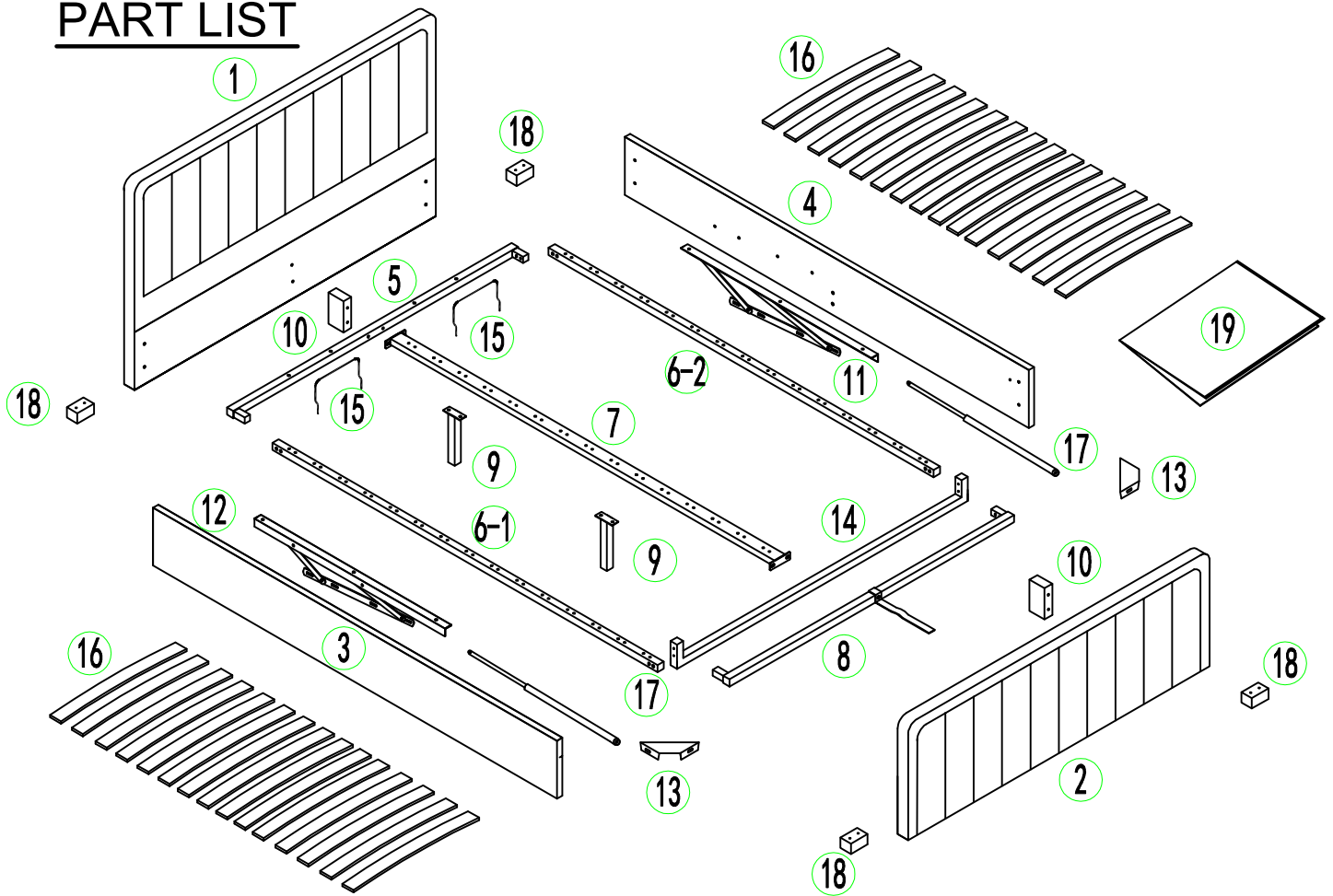

HARDWARE LIST

Label	Picture	Description	Qty	Label	Picture	Description	Qty
A		Single Plastic Cap	30	H		Bolt M6x20	4
B		Double Plastic Cap	15	I		Screw 4x45	8
C		Bolt M8x20	16	J		Bolt M8x35	8
D		Bolt M6x35	4	K		Bolt M8x15	22
E		Washer M8	8	L		Connection Plate Left	2
F		Nut	4	R		Connection Plate Right	2
G		Bolt M6x70	4	M		Plastic pad	8

TOOL list

Label	Picture	Description	Qty
T-1		Screw driver(not provided)	1
T-2		Allen key M5	1
T-3		Allen key M4	1
T-4		Spanner	1

Step 1

I  8pcs



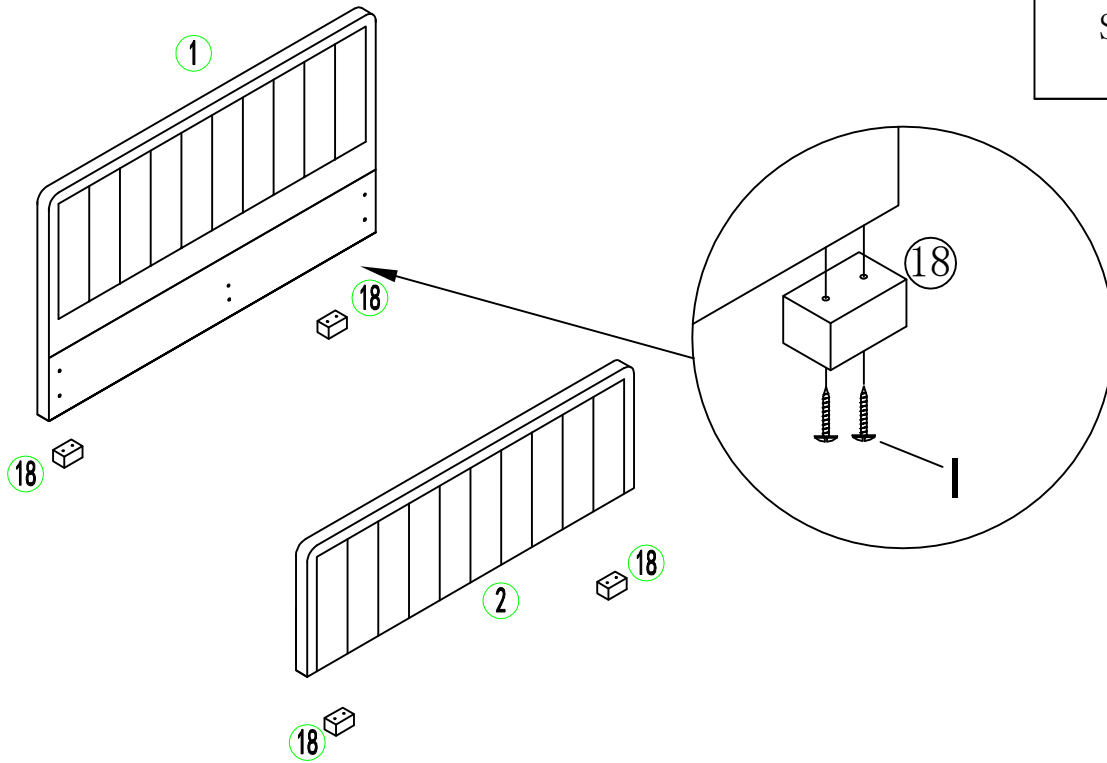

Screw 4x45



Step 2

Step 2a

Step 2b

L  2pcs	R  2pcs
Connection Plate Left	Connection Plate Right
C  16pcs	H  4pcs
Bolt M8x20	Bolt M6x20
	E  8pcs
	Washer M8

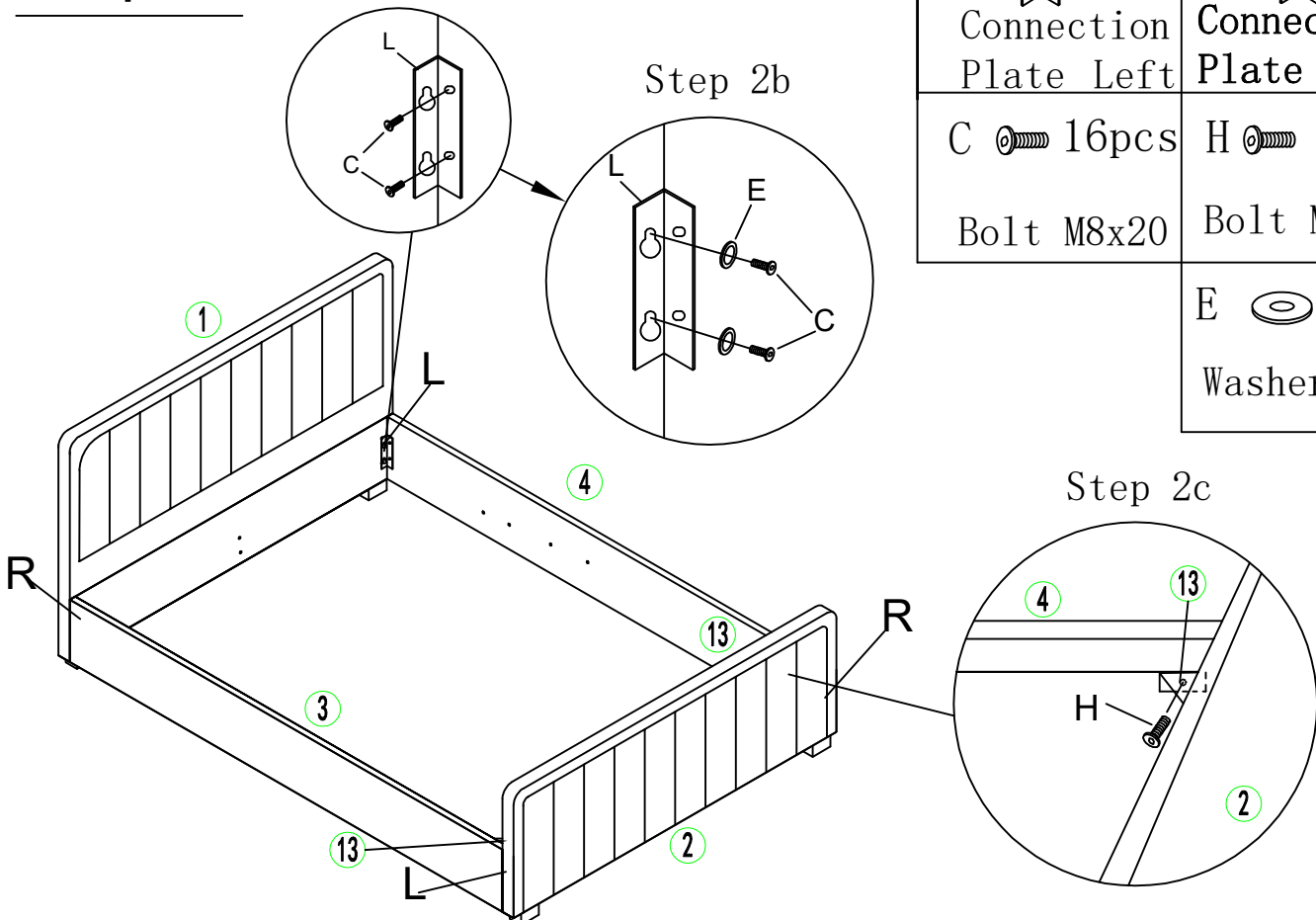

Step 2c

Step 3

G  4pcs

J  8pcs

Bolt M6x70

Bolt M8x35

M  8pcs

Plastic pad

Step 3a

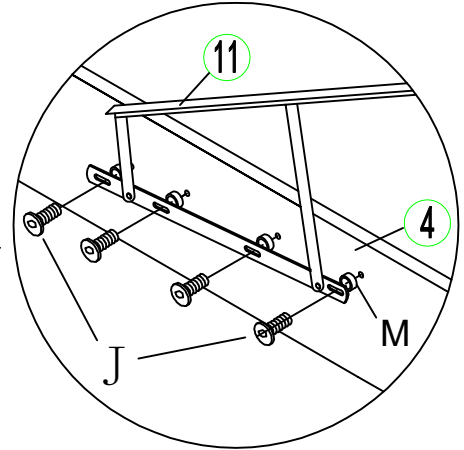
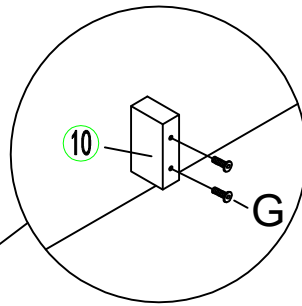
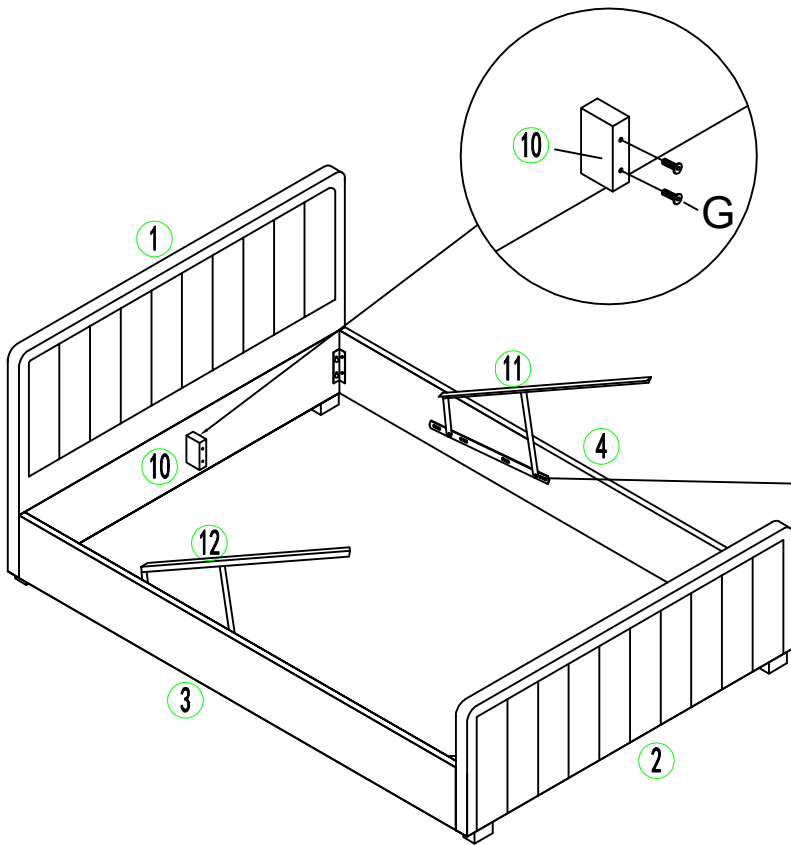

Step 3b

Step 4

K  16pcs

Bolt M8x15

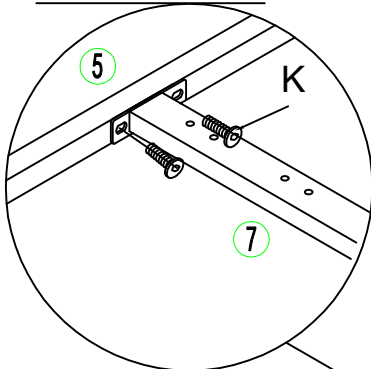

Step 4b

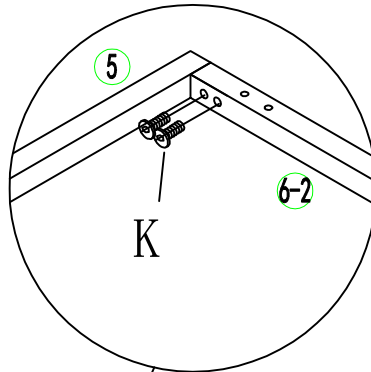

Step 4a

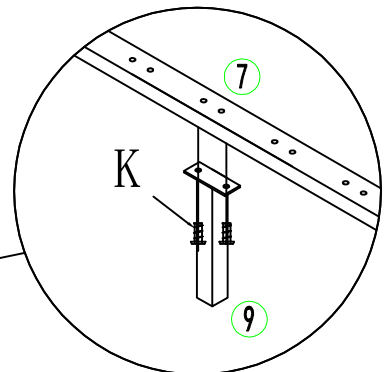
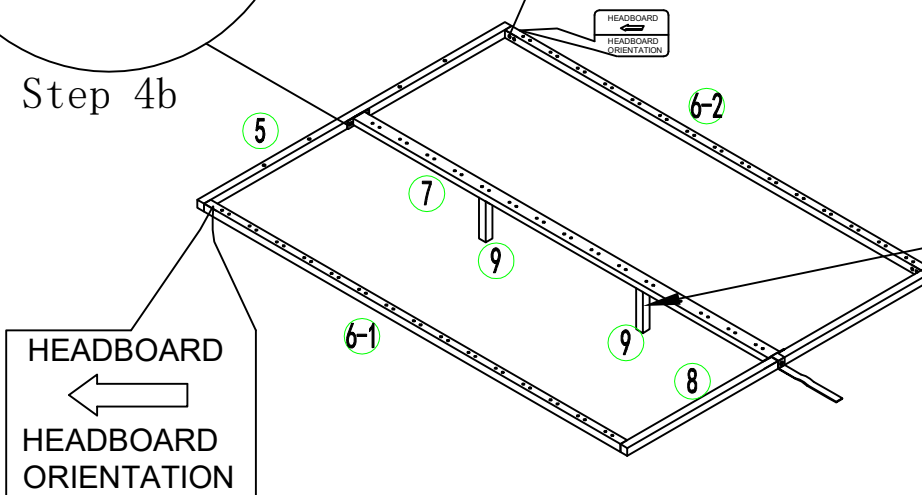

Step 4c

HEADBOARD
←
HEADBOARD
ORIENTATION

Step 5

K  6pcs
Bolt M8x15

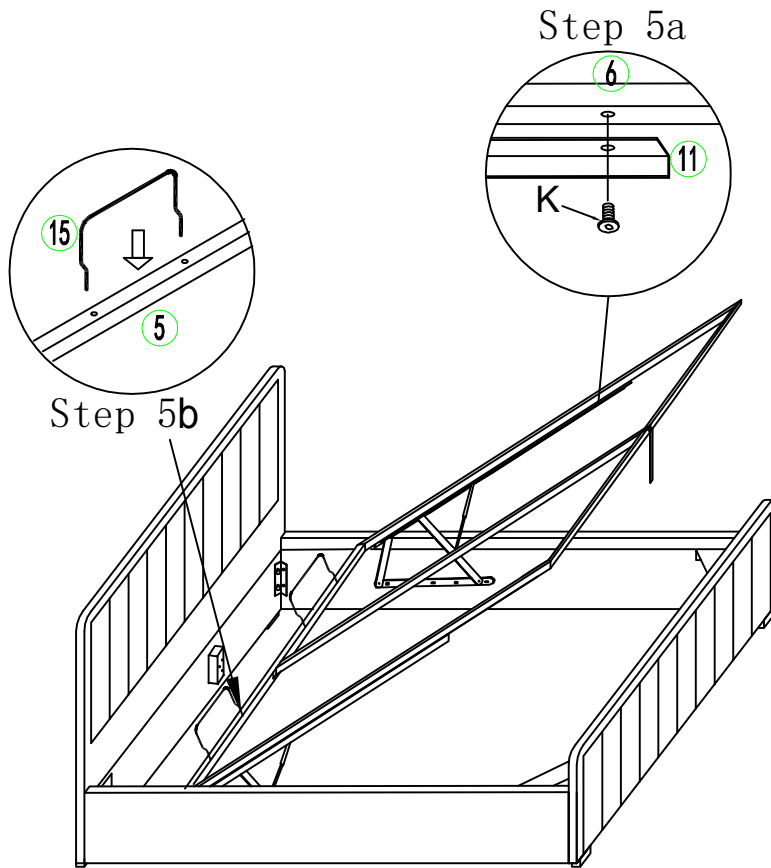

Step 6 Attach non-woven-fabric

Turn bed on its side and attach non-woven-fabric (19) to base.

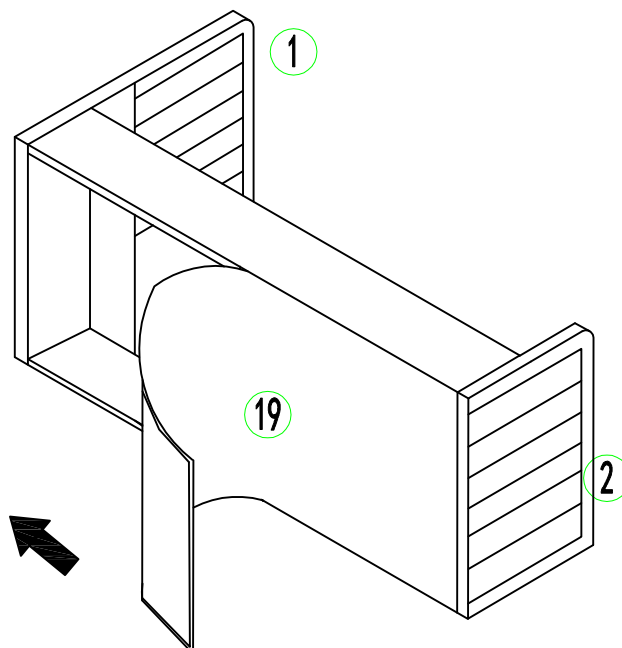

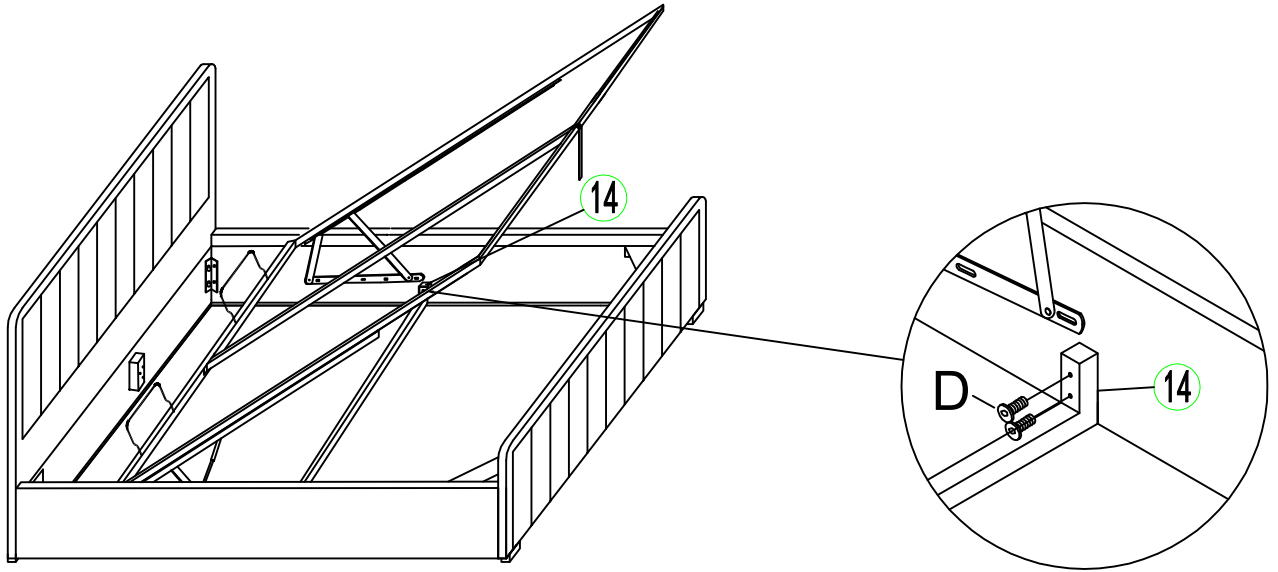

Step 7

D  4pcs
Bolt M6x35



Step 8

A  30pcs Single Plastic Cap	B  15pcs Double Plastic Cap
--	--

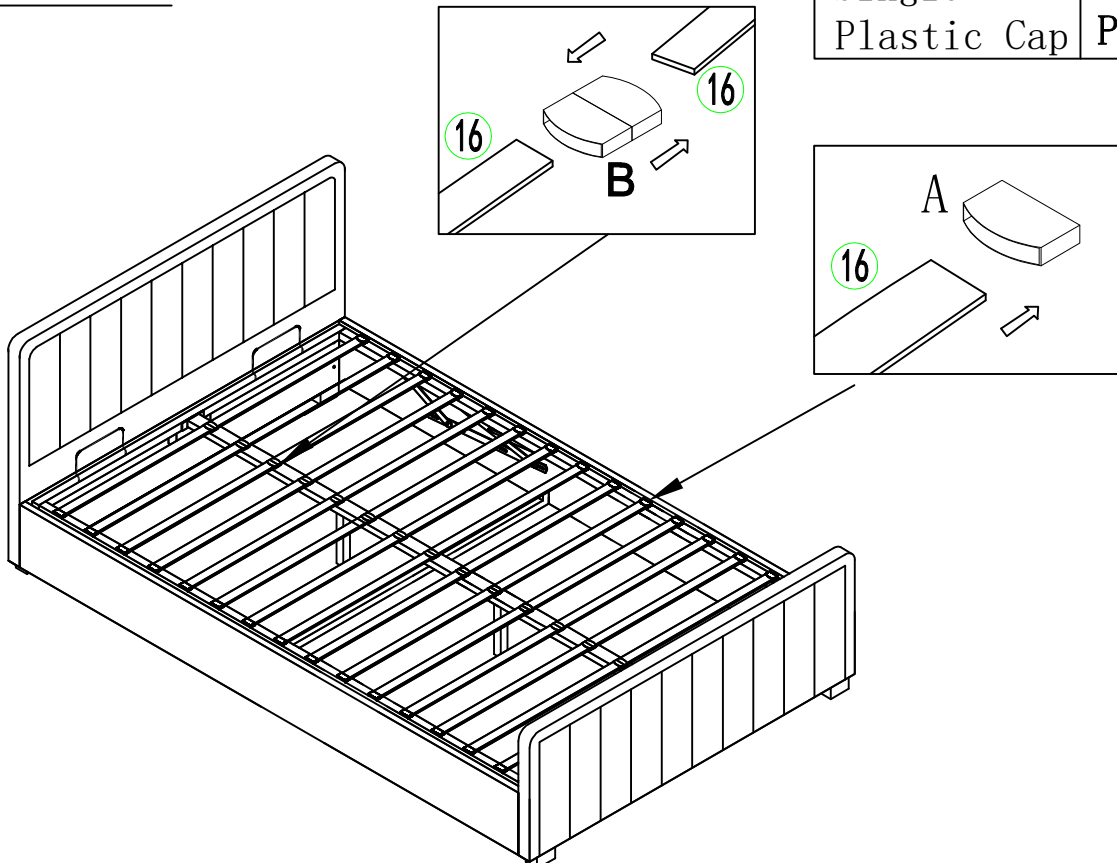

Step 9

F  4pcs

Nut

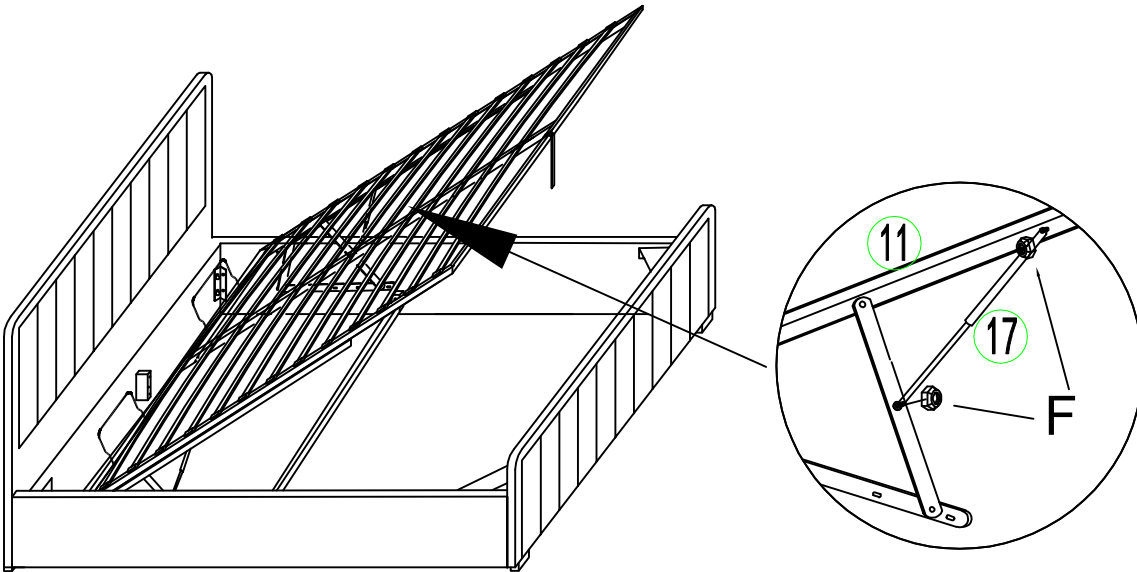

NOTE: Do Not Overtighten

Step 10

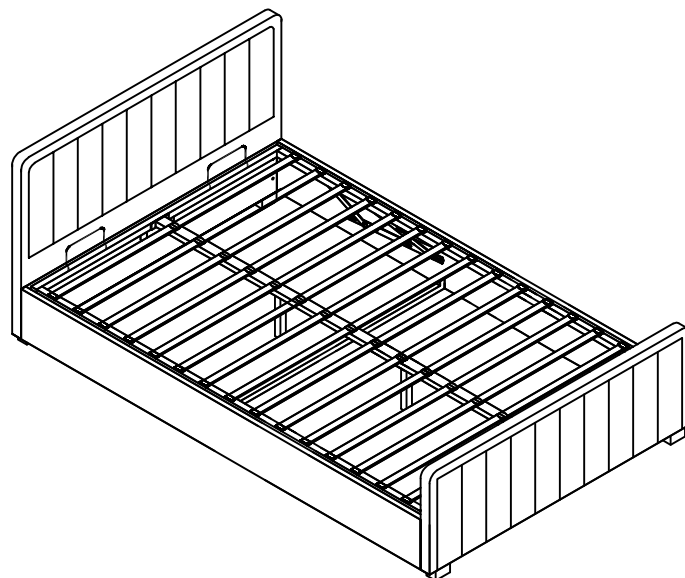

Attention: Please remove mattress from the bed should you wish to clean the floor under the bed. Dragging the bed around with mattress might compromise the bed construction, stability or cause permanent damage.

IMPORTANT INFORMATION

OTTOMAN OPERATING INSTRUCTIONS

Once your bed frame is completely assembled, the slat frame unit will not operate correctly unless a mattress is placed on the slat frame. Position the mattress onto the slat frame whilst it is in the closed position.

The pistons used in the construction of this product are extremely strong and cannot be operated by hand when not fitted to the ottoman hinges. All pistons are tested in the factory for correct pressure and operation before use.

Initially it might appear that the pistons are very stiff when opening and closing the ottoman frame, THIS IS NORMAL.

After operating the ottoman a few times, the movement of the pistons and the opening and closing of the ottoman will become easier.

PLEASE NOTE - It takes a lot of force to make the initial movement of the ottoman. **THIS IS A DESIGN FEATURE OF THE PRODUCT SO THAT IT DOES NOT FALL SHUT.**

When the ottoman is almost shut, it will close completely under its own weight. The speed of closing depend on the weight of the mattress so always keep fingers clear of the frame.

Periodically check and tighten bolts to ensure that the components are tight and secure.

When lowering the slat unit for the first time, take care to make sure it does not rub unevenly on the inside face of the Side Rail. If it does, the bed has been assembled slightly out of square. This can be rectified by moving the Footboard of the bed slightly to the left or right whilst leaving the headboard of the bed frame stationary.

If you are experiencing difficulty with the initial compression try fitting one piston at a time (following the Assembly Instructions) then press down on the side of the frame with the piston fitted - this acts like a big lever (The weight of the mattress can be used to supplement the load exerted). Effectively you are doubling the amount of force applied, because you have halved the resistance offered by the pistons. It can take slightly more effort than you might feel comfortable applying to the bed frame at first.

WARNING

For the safety of yourselves and others, please ensure that:

- **Children and pets are not left unattended when the frame is in the lifted position as they could become trapped inside the ottoman space.**
- **Please keep children and pets away from the ottoman bedstead whilst opening and closing the slat frame to avoid injury.**
- **The items store under the bed - i.e. the top of an item must not touch the underside of the mattress metal frame base or it may get damaged.**

ATTENTION Important Notes Regarding Gas Lifts

This information applies to all types of gas lift storage, regardless of the base top: boarded base ① or wooden slats ② and regardless of opening configuration: end opening ① / side opening ②

NEVER OPEN OR CLOSE WITHOUT A MATTRESS ON TOP OR YOU RISK TWISTING THE FRAME, DAMAGING THE BED OR PERSONAL INJURY!

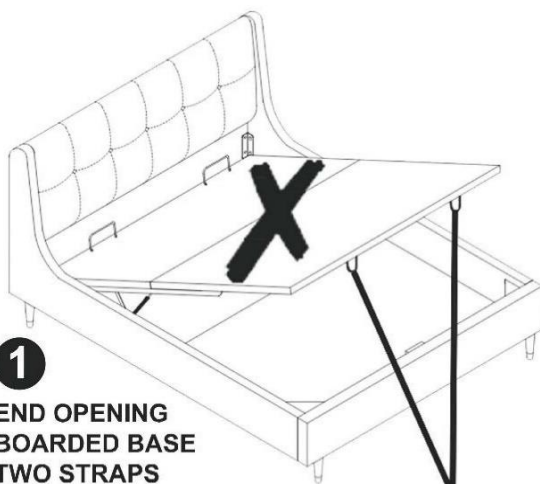

TO OPEN, USE
SAFETY STRAP(S)
TO LIFT THE MATTRESS

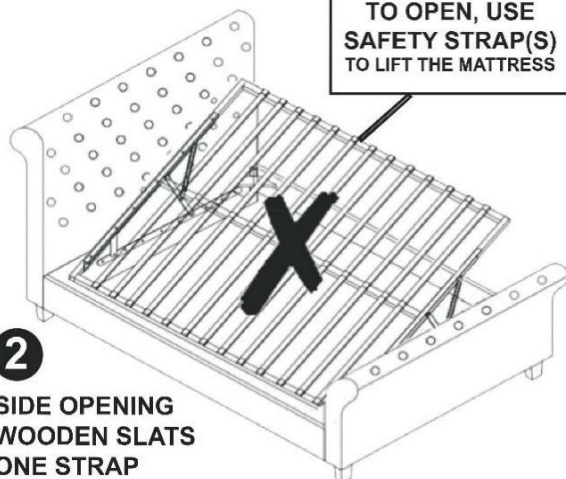

③ ONCE THE MATTRESS IS ON TOP,
YOU CAN OPEN & CLOSE
THE BED SAFELY ✓

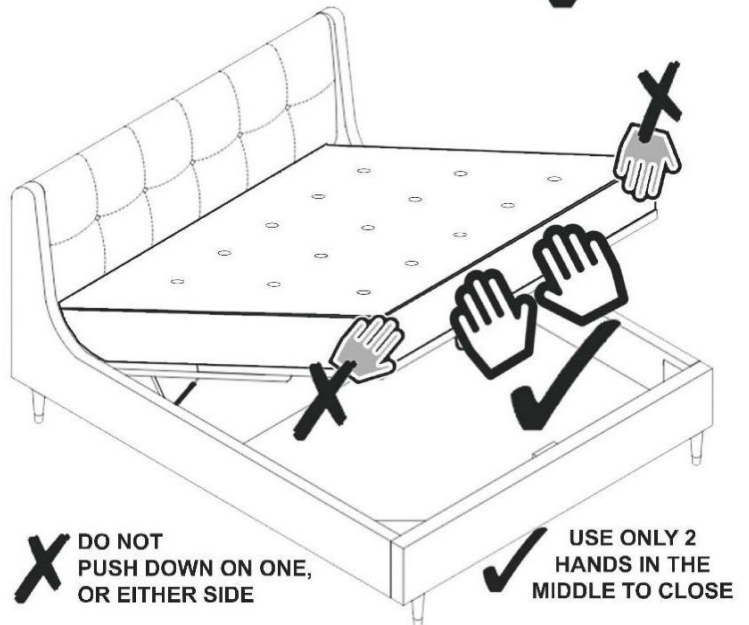

Once all the nuts and bolts are tightened firmly, the first time you close the lifting mechanism, push down with extra pressure to force open the seals on the pistons.

This will feel like a lot of pressure, so be firm and it will close!

1. NEVER operate without a mattress on top. Failure to do so will damage the bed.
2. Close by pushing down firmly, with both hands towards the centre, with equal pressure.
3. NEVER push down on only one side or edge, or you will damage your bed.
4. NEVER sleep on the bed frame without a mattress.
5. Please remember to re-tighten all nuts & bolts within the bed frame after 2 weeks of use.

Hints and Tips

Failure to do so may result in injury.

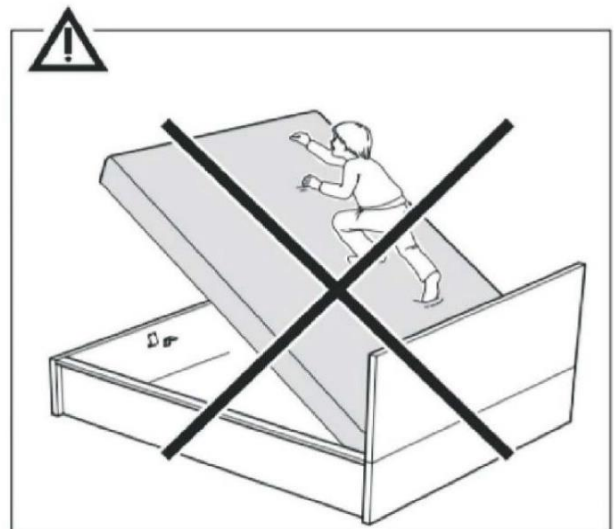
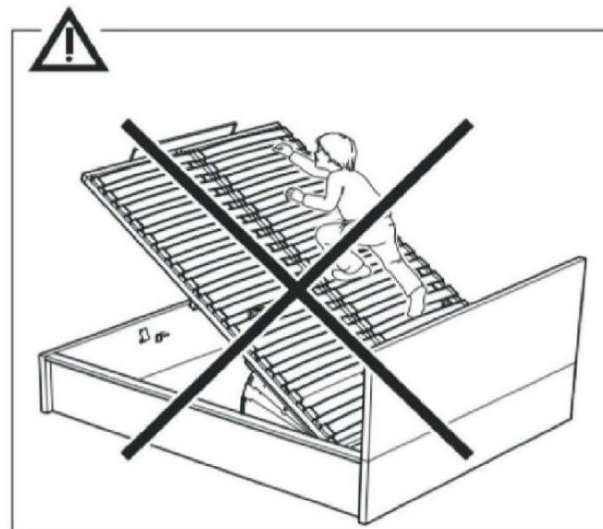
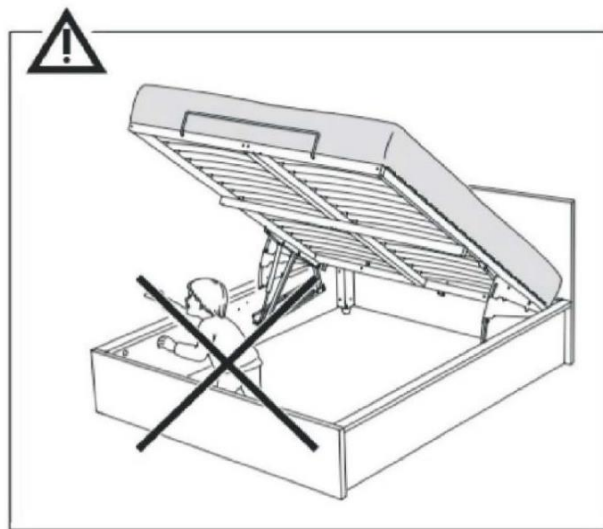

Bed frame must be in CLOSED position when moving the bed.

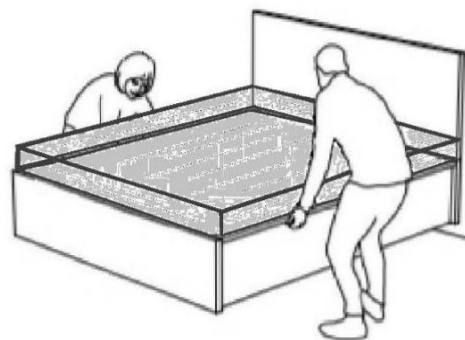
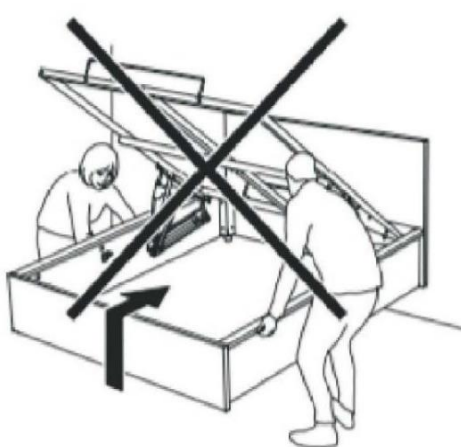

Hints and Tips

Failure to do so may result in injury.

To operate the ottoman, always use two hands at arm's length to push down on the bed frame end, in between the 2 rows of slats (as shown below) to close the bed frame.

To open, lift up using the nylon strap on the bed end. You must always ensure the mattress is on the bed frame before lifting to open and close the bed frame.

The weight of the mattress loaded on the frame helps to close the bed frame easier and with less effort, also keep the frame in closed position until it is pulled upwards by user.



Always ensure Mattress is on the bed frame

