

FR. INSTRUCTIONS D'ASSEMBLAGE EN. ASSEMBLY INSTRUCTIONS

PT. INSTRUÇÕES DE MONTAGEM
ES. INSTRUCCIONES DE ENSAMBLAJE
IT. ISTRUZIONI DI MONTAGGIO
DE. MONTAGEANLEITUNG
NL. MONTAGE-INSTRUCTIES

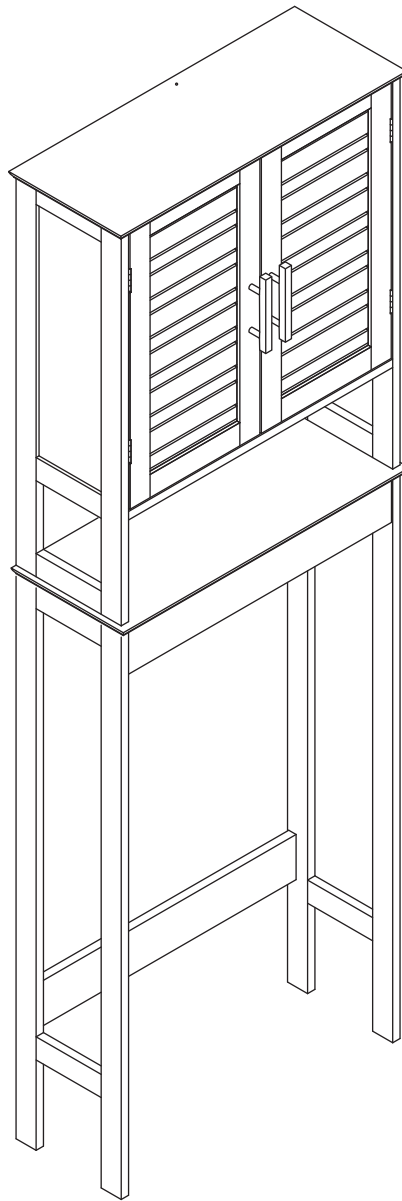

9904-763

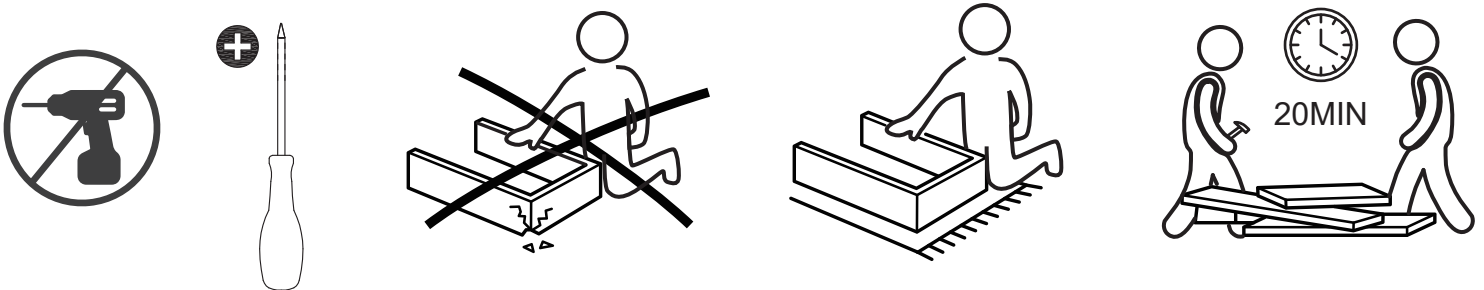

FR. INFORMATIONS À CONSERVER POUR CONSULTATION ULTÉRIEURE - À LIRE ATTENTIVEMENT
EN. INFORMATION TO BE RETAINED FOR FUTURE REFERENCE - READ CAREFULLY
PT. INFORMAÇÕES A SEREM MANTIDAS PARA CONSULTA FUTURA - LEIA ATENTAMENTE
ES. INFORMACIÓN A CONSERVAR PARA CONSULTA FUTURA - LEER ATENTAMENTE
IT. INFORMAZIONI DA CONSERVARE PER FUTURE CONSULTAZIONI - LEGGERE ATTENTAMENTE
DE. INFORMATIONEN ZUR SPÄTEREN NACHSCHLAGE - AUFMERKSAM LESEN
NL. INFORMATIE VOOR LATER BEWAREN - ZORGVULDIG LEZEN









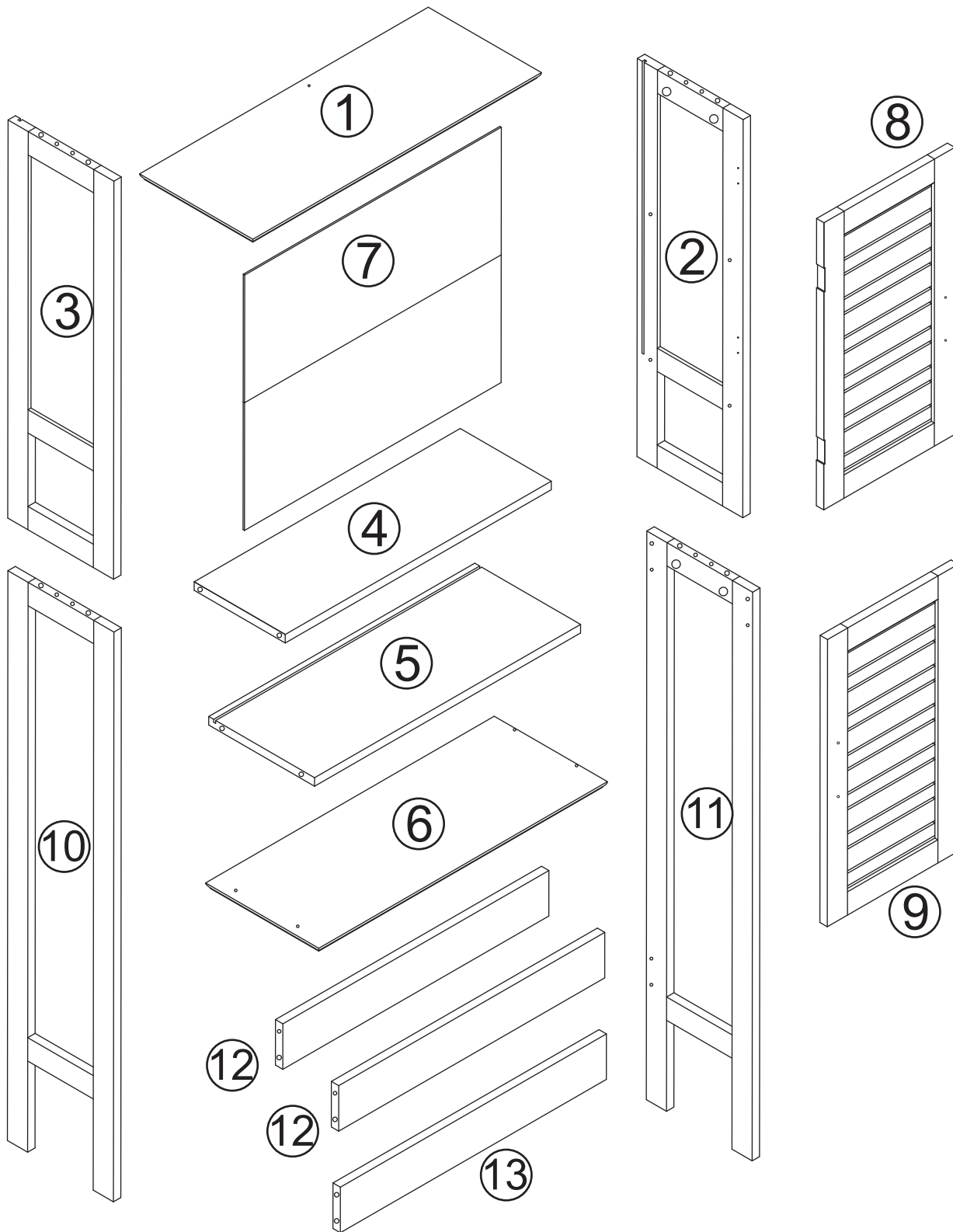

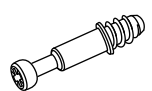

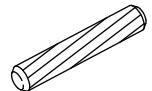

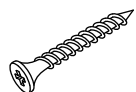

Importé par - Imported by - Importado por
Importato da - Importiert bei - Geïmporteerd door

TENDANCE

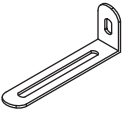
27 boulevard des Etines 42120 LE COTEAU - FRANCE
TVA intracommunautaire N° FR38 500 766 324
www.tendance-bain.com

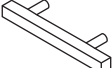

A 6x35mm  x24	B 15x10mm  x24	C 6x30mm  x12	D  x1	E 3x14mm  x6	F  x4
G 3x12mm  x18	H  x2	I 4x35mm  x5	J 4x12mm  x1	K  x1	L  x1
M  x4	N  x4	O  x4	P  x2		2/12

1

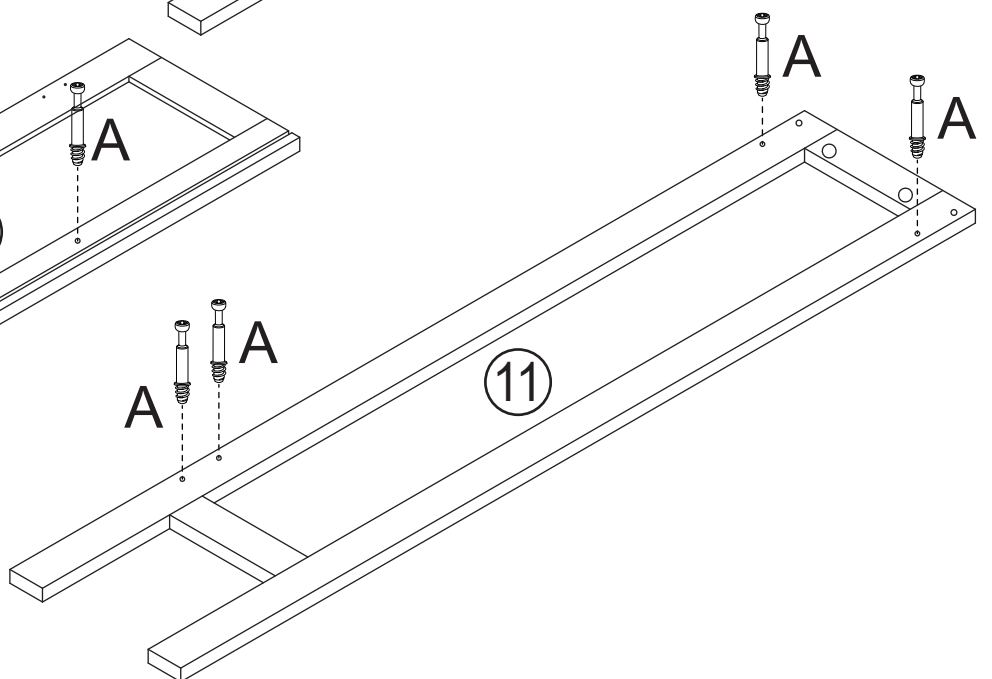
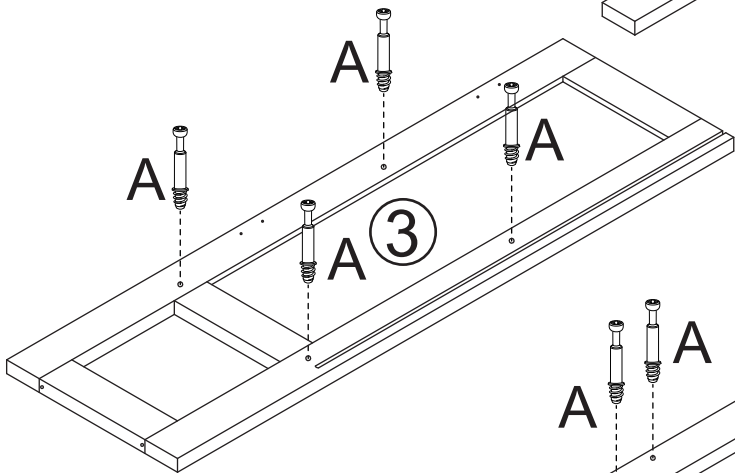
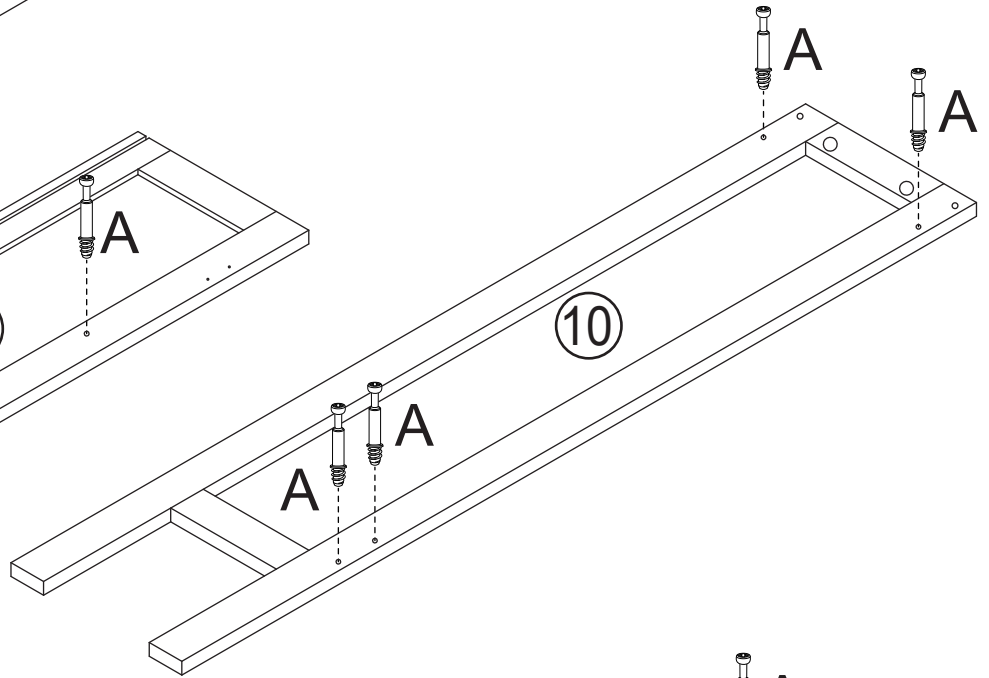
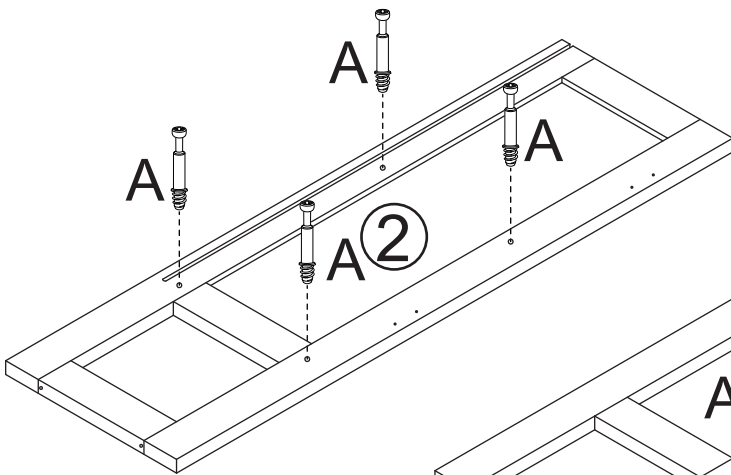
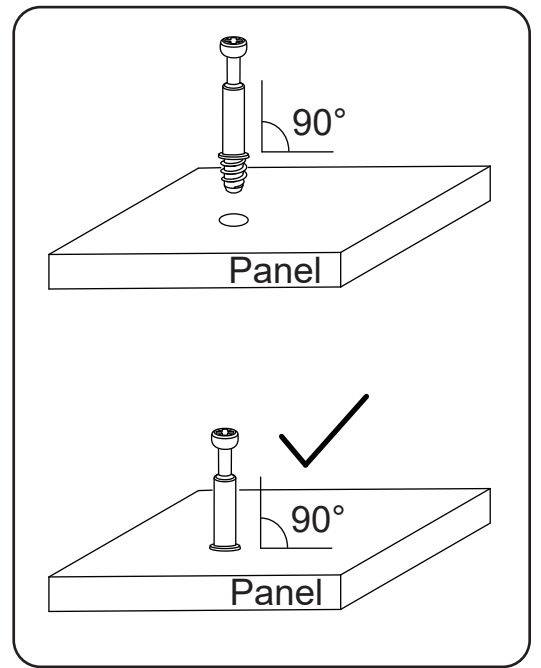
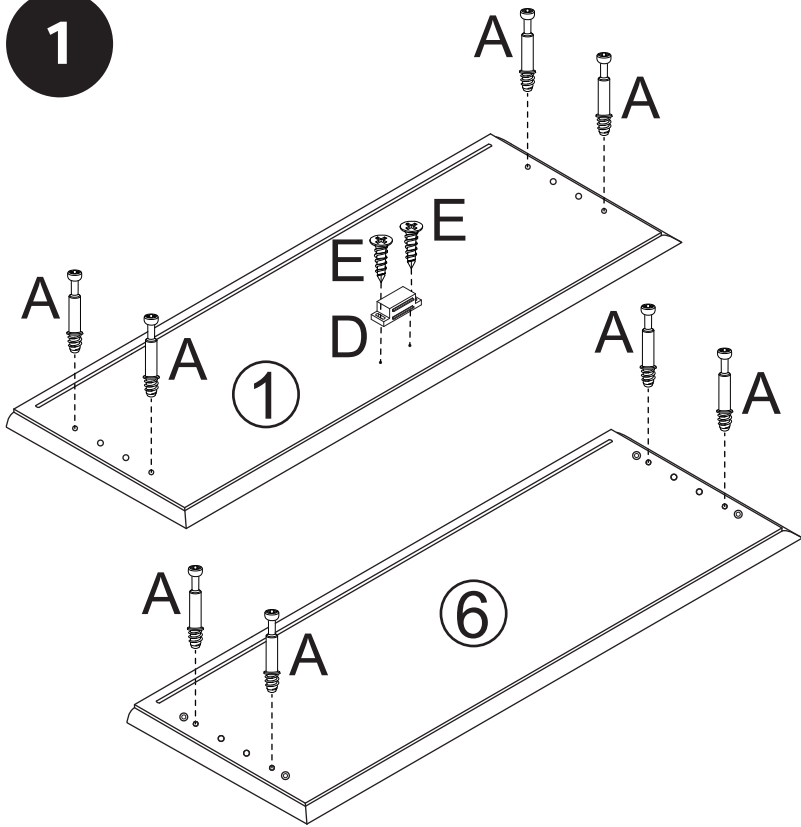

2

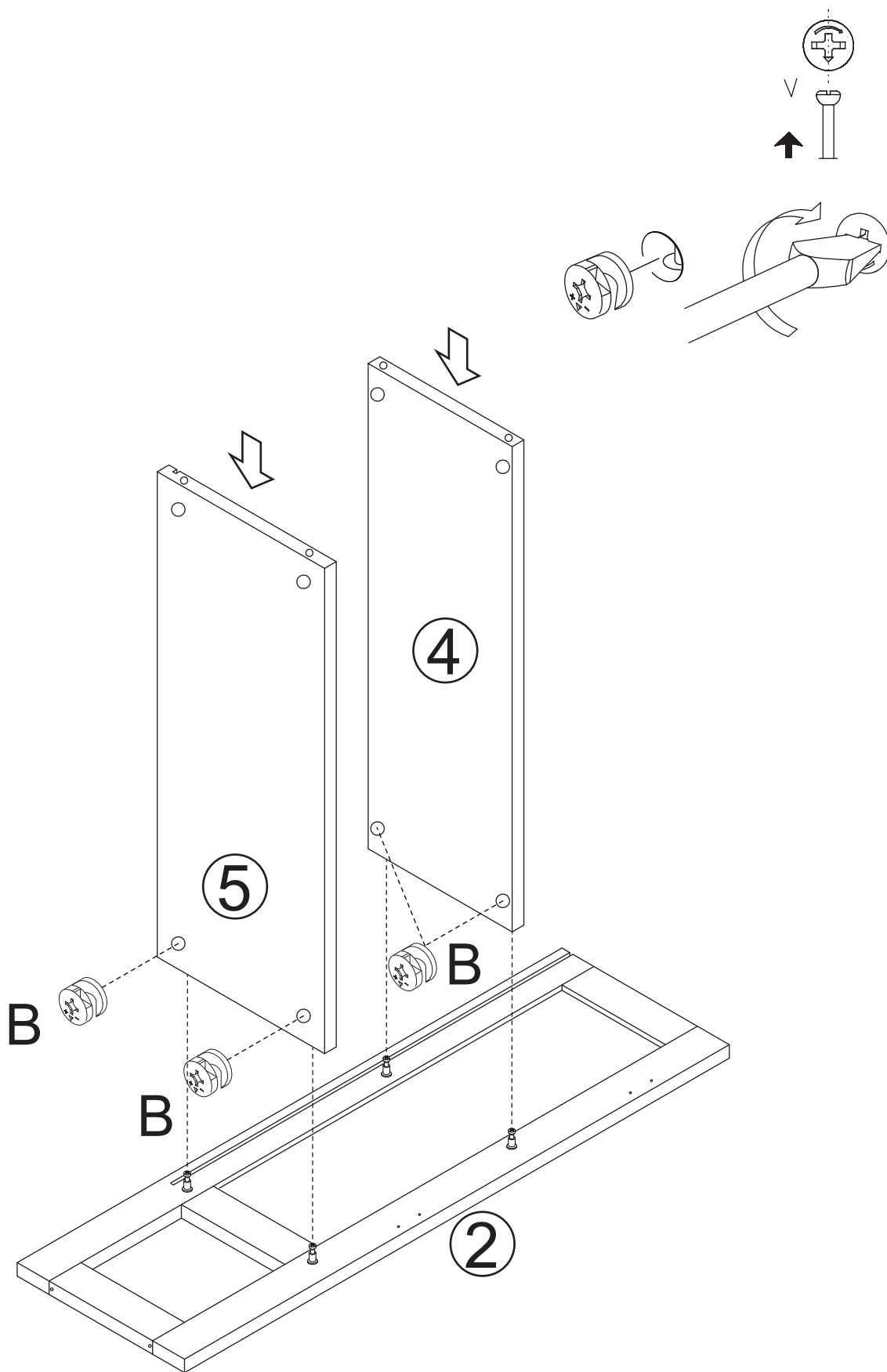

3

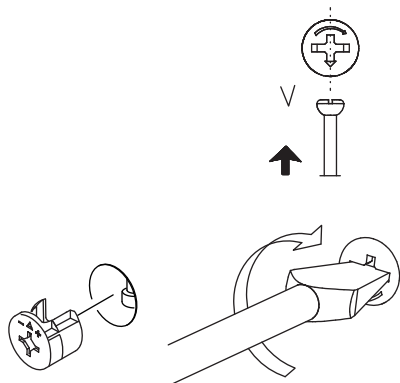
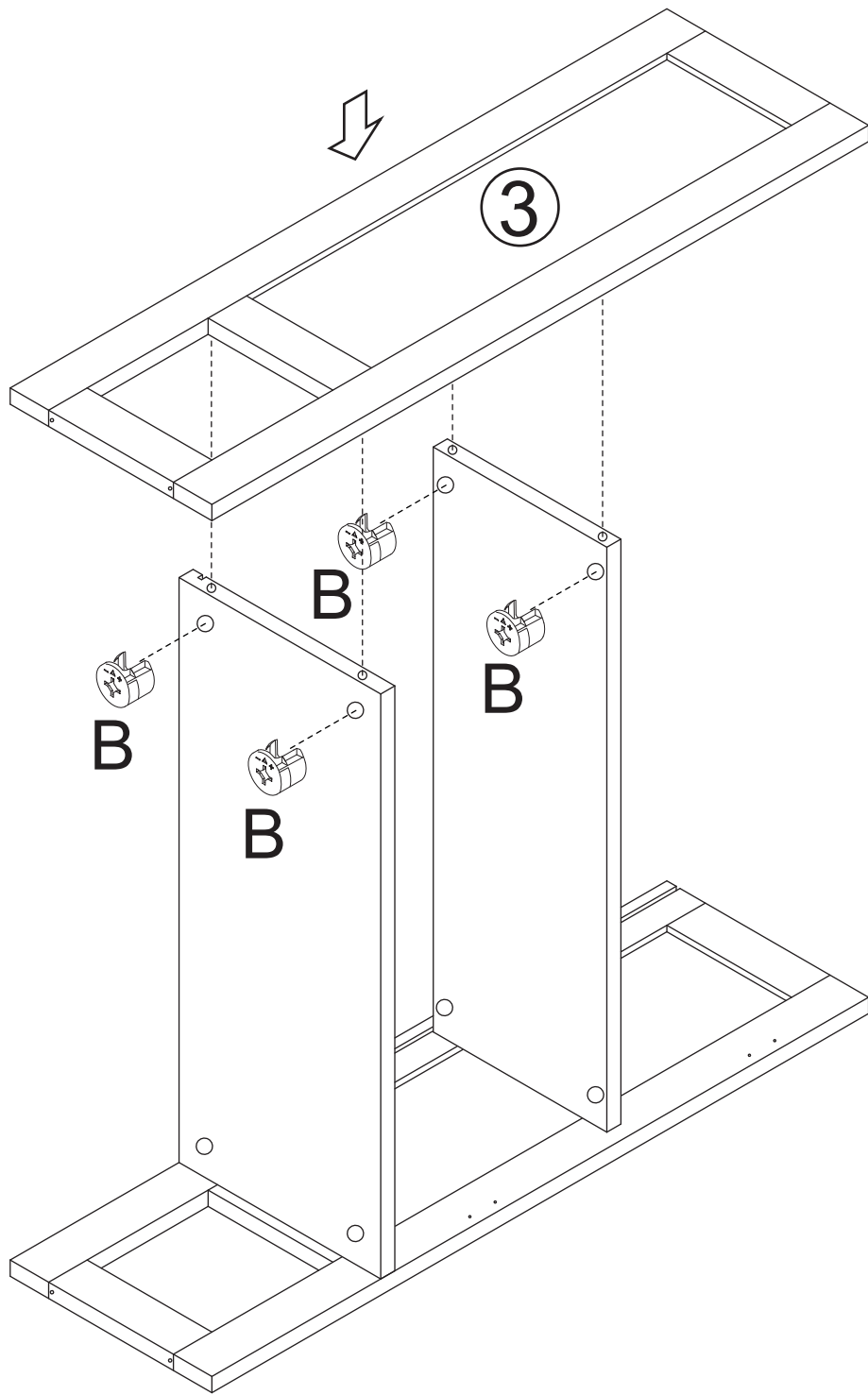

4

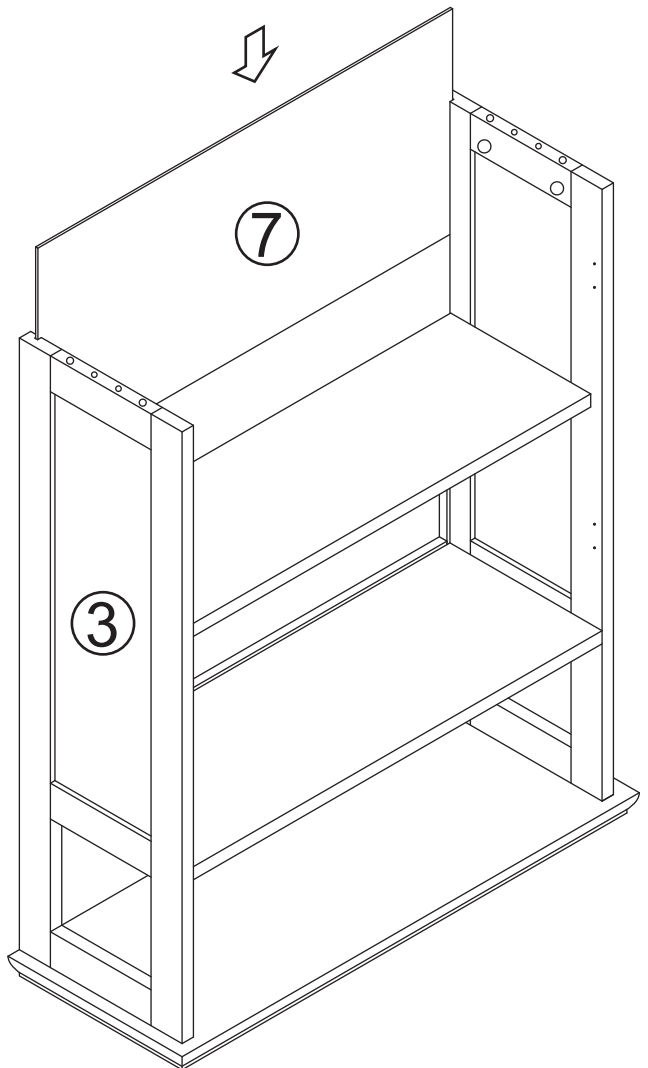
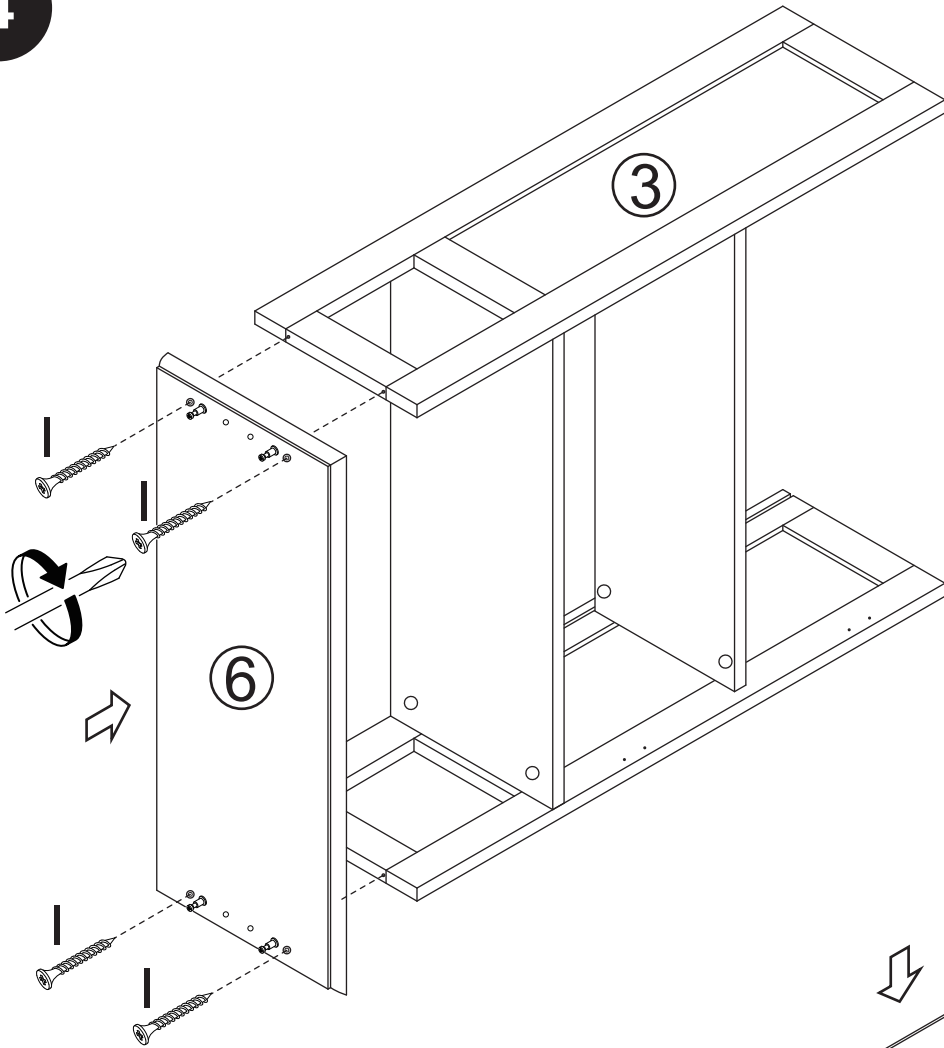

5

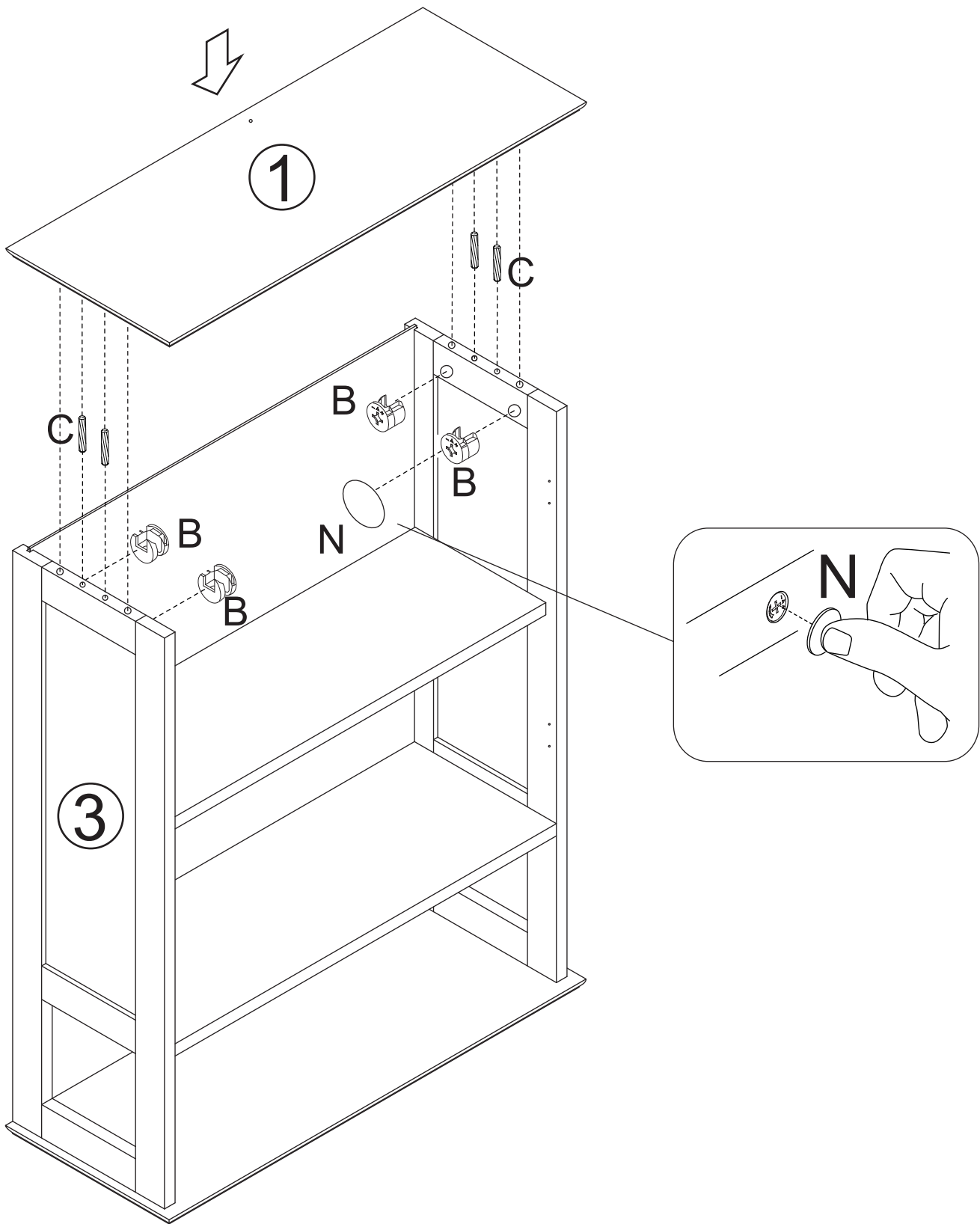

6

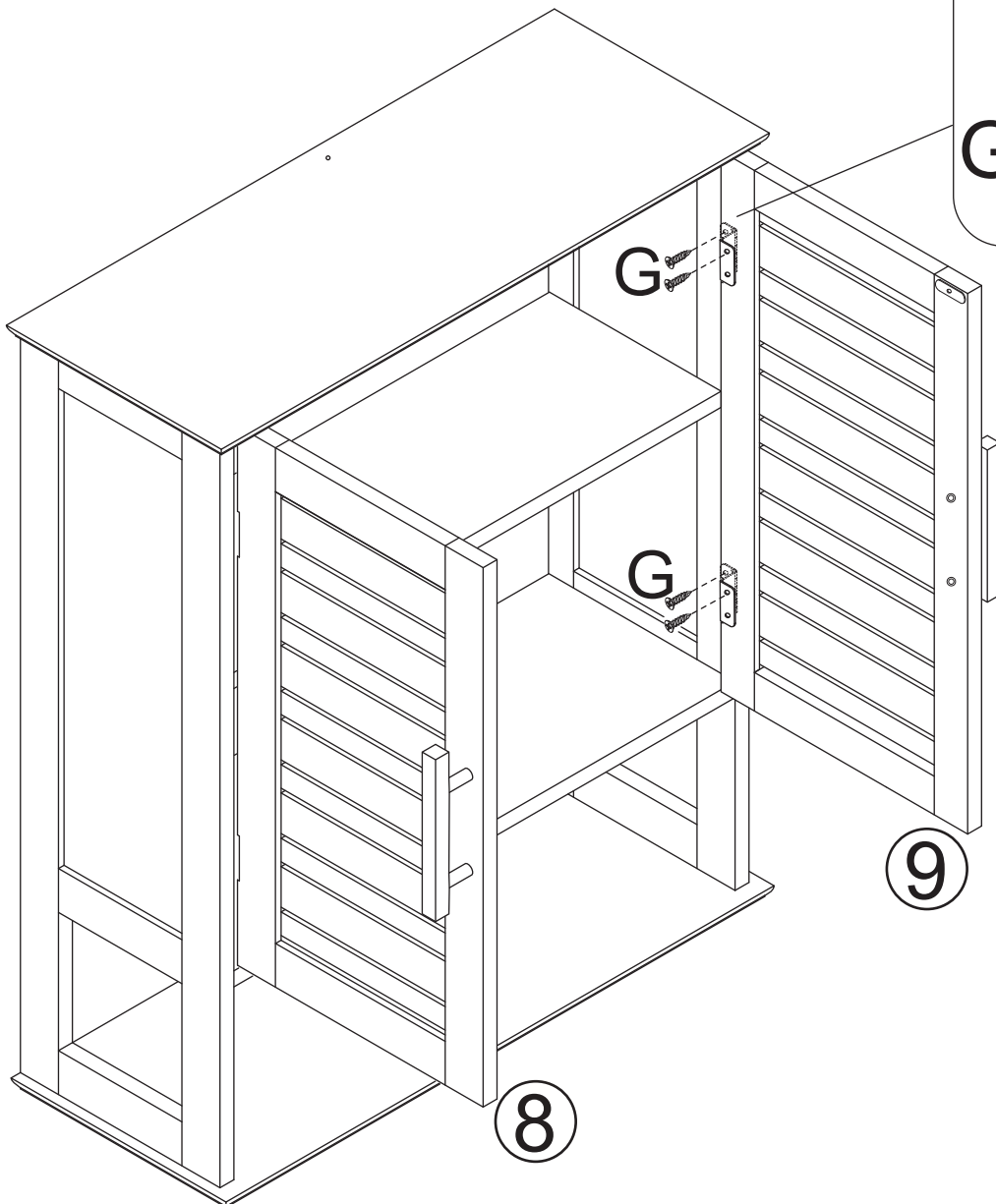
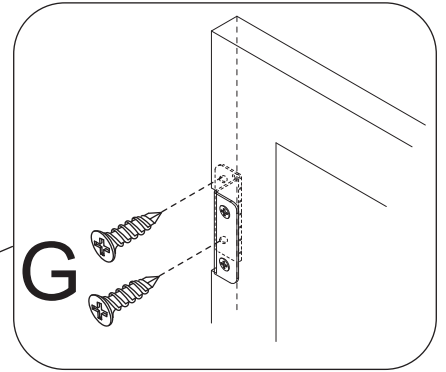
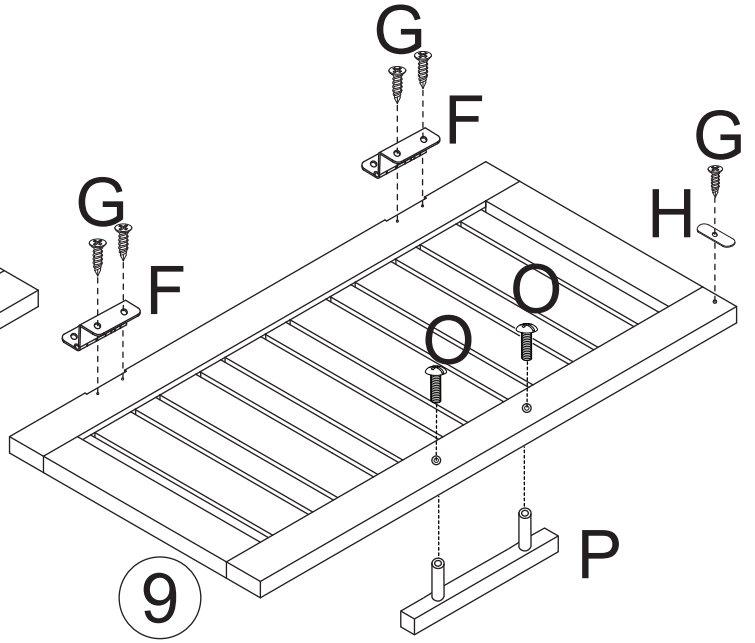
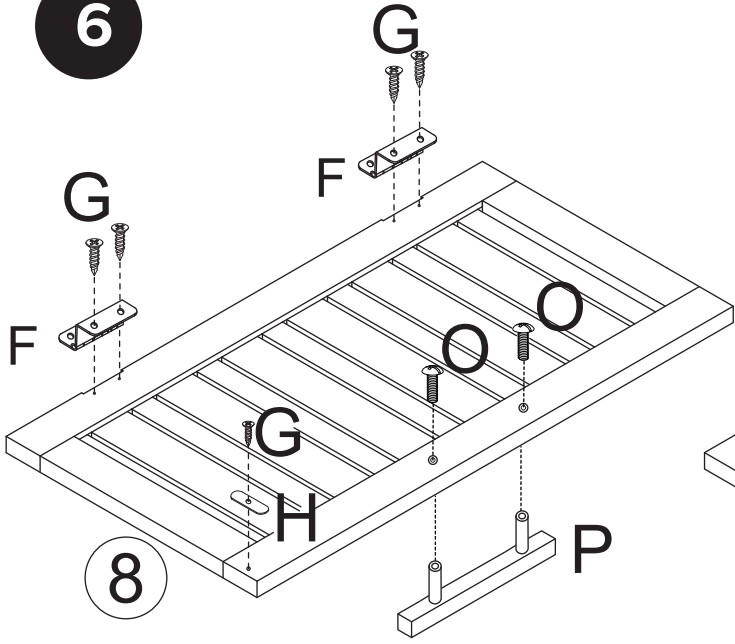

7

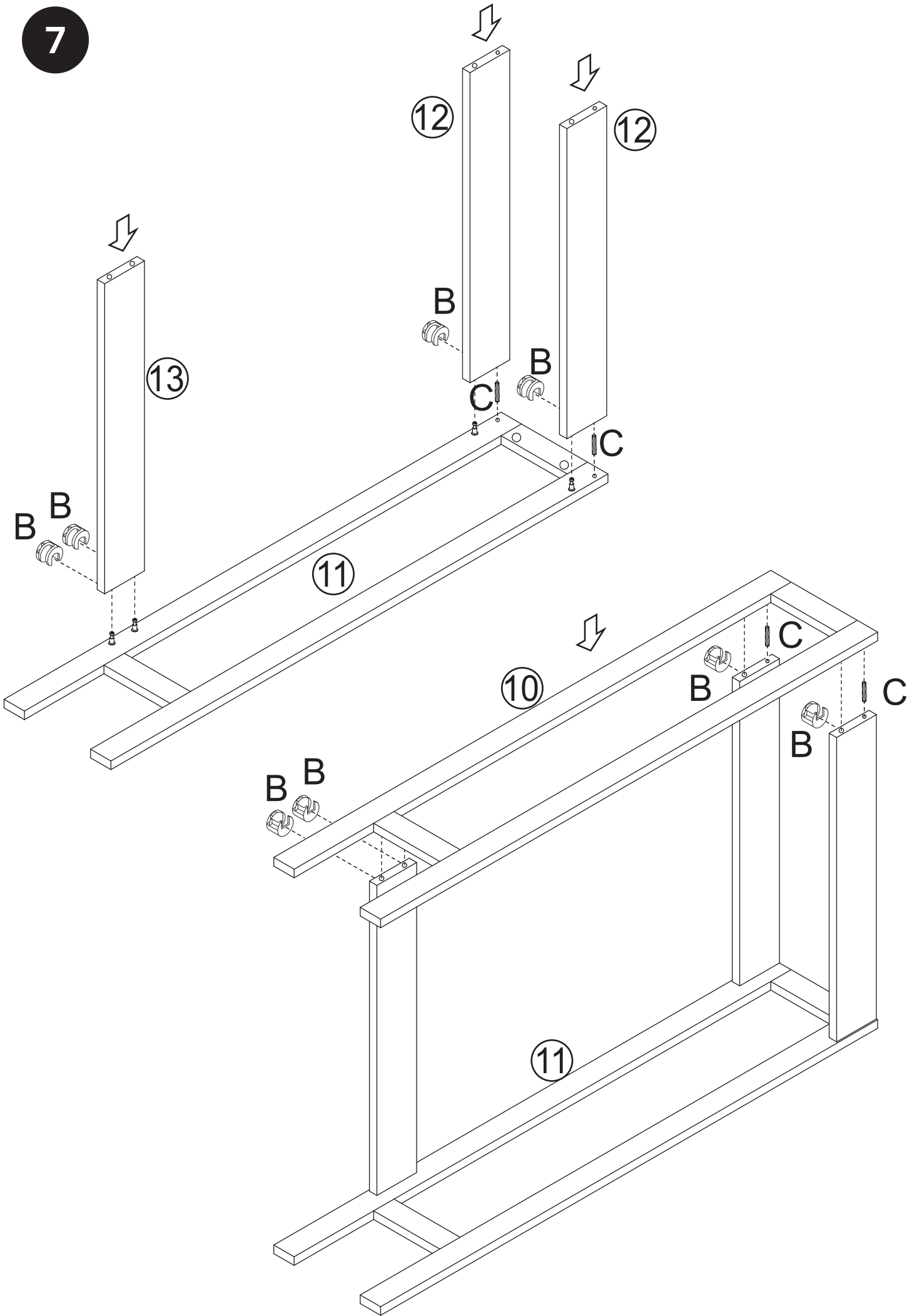

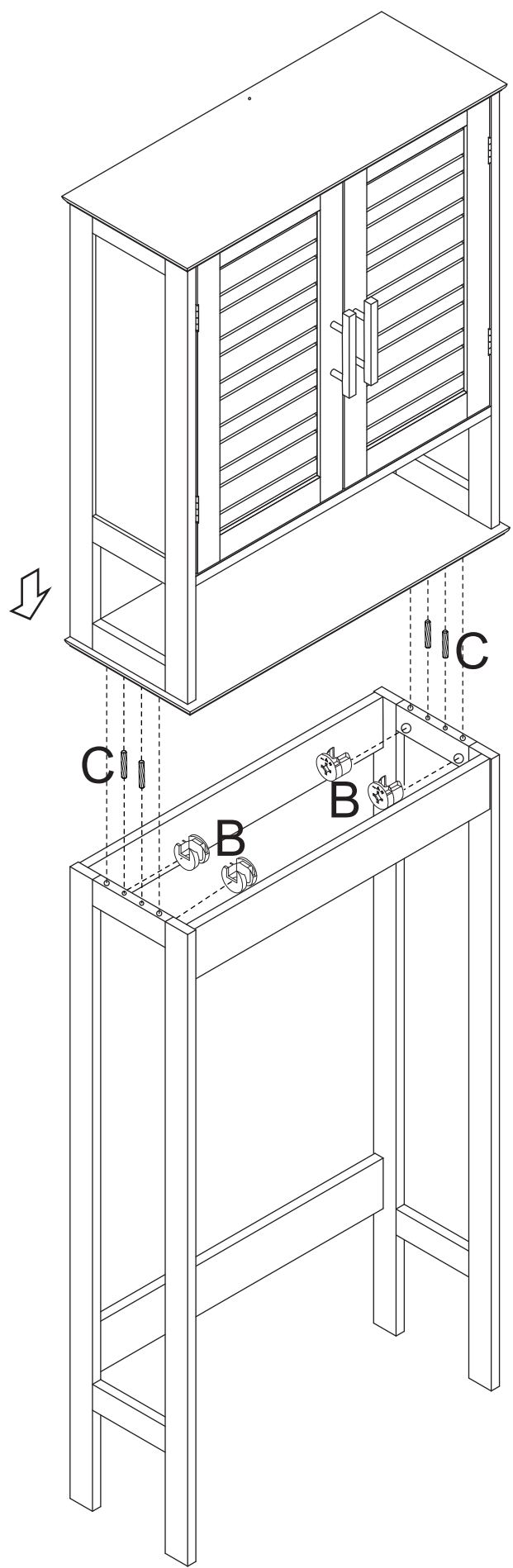

9

FR. Avant de fixer "M", s'assurer que la dimension "XX=YY"

EN. Before fix "M", please make sure size "XX=YY".

PT. Antes de corrigir "M", certifique-se de que o tamanho "XX = YY".

ES. Antes de corregir "M", asegúrese de que el tamaño "XX=YY".

IT. Prima di correggere "M", assicurarsi che la taglia "XX=YY".

DE. Bevor Sie „M“ reparieren, stellen Sie bitte sicher, dass die Größe „XX=YY“ ist.

NL. Voordat u "M" repareert, zorg ervoor dat maat "XX=YY" is.

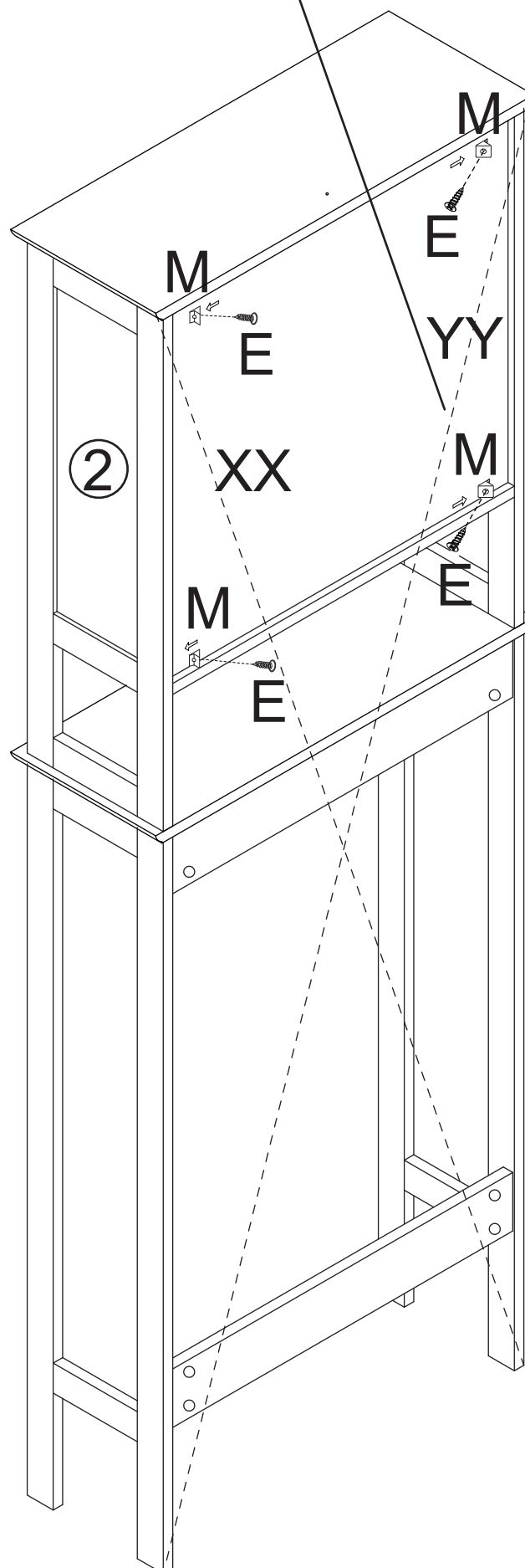

10

