

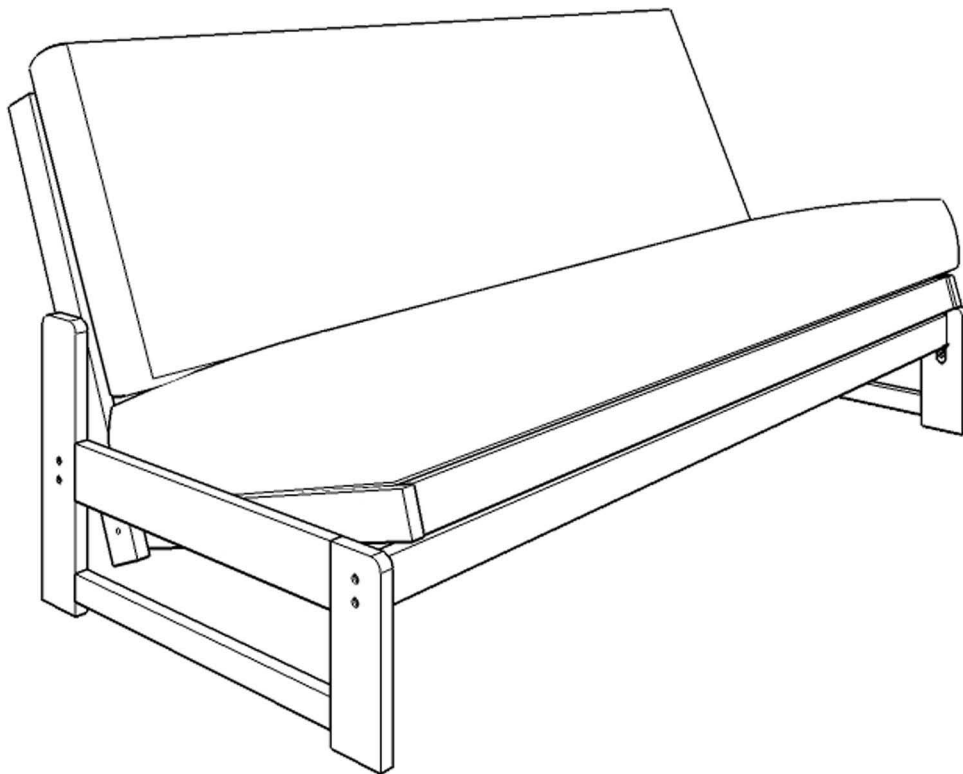

Futon Frame

Assembly Instructions



Required:

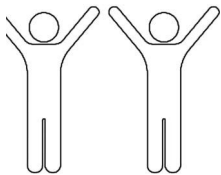

Tools Needed:



Allen Key provided

Please cover floor with corrugated cardboard / paper / carpet
to avoid scratches / damages to floor



Body

Assembly Instructions

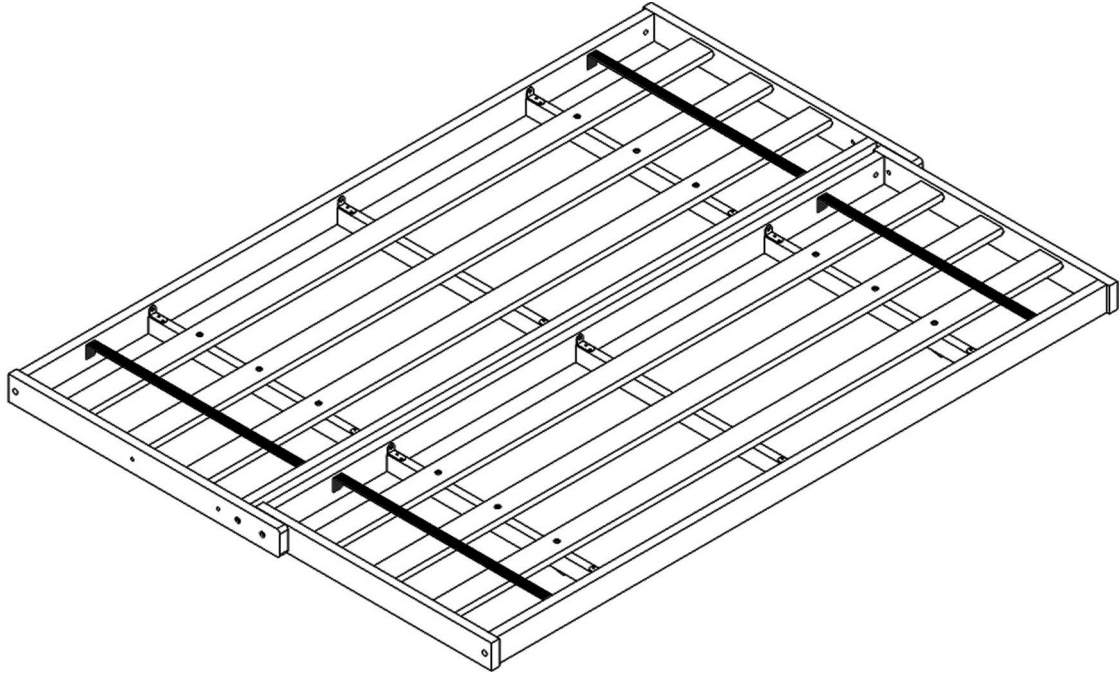

Recommended:

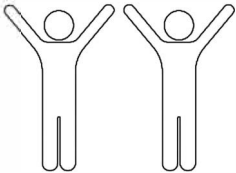

Tools Needed:



Allen Key provided

Please cover floor with corrugated cardboard / paper / carpet
to avoid scratches / damages to floor

Assembly Checklist

Please make sure that you have all of the below items before you start. If any are missing, please contact us for a replacement.



Parts supplied for assembly

Box A

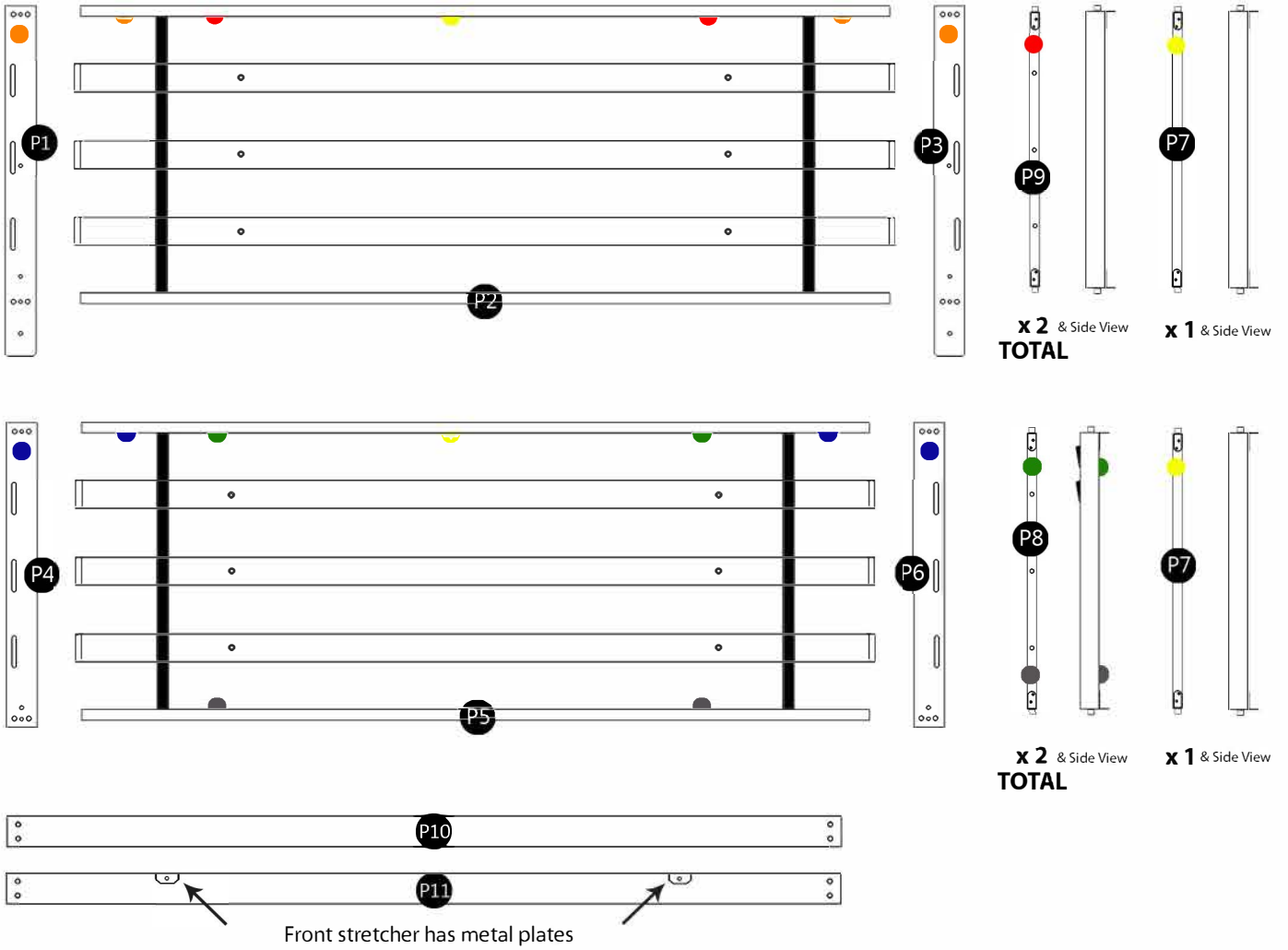

Hardware supplied for assembly

Tools required for assembly:
- Allen Key (supplied)

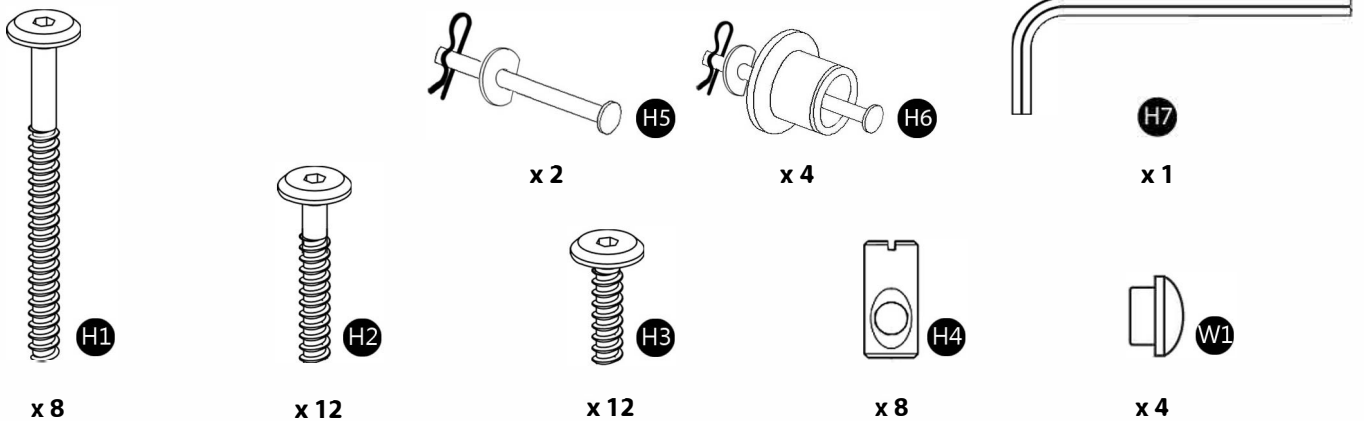

Step 1: Locate parts P2, P9(2), & P7

Use colored dots to align parts for connection.

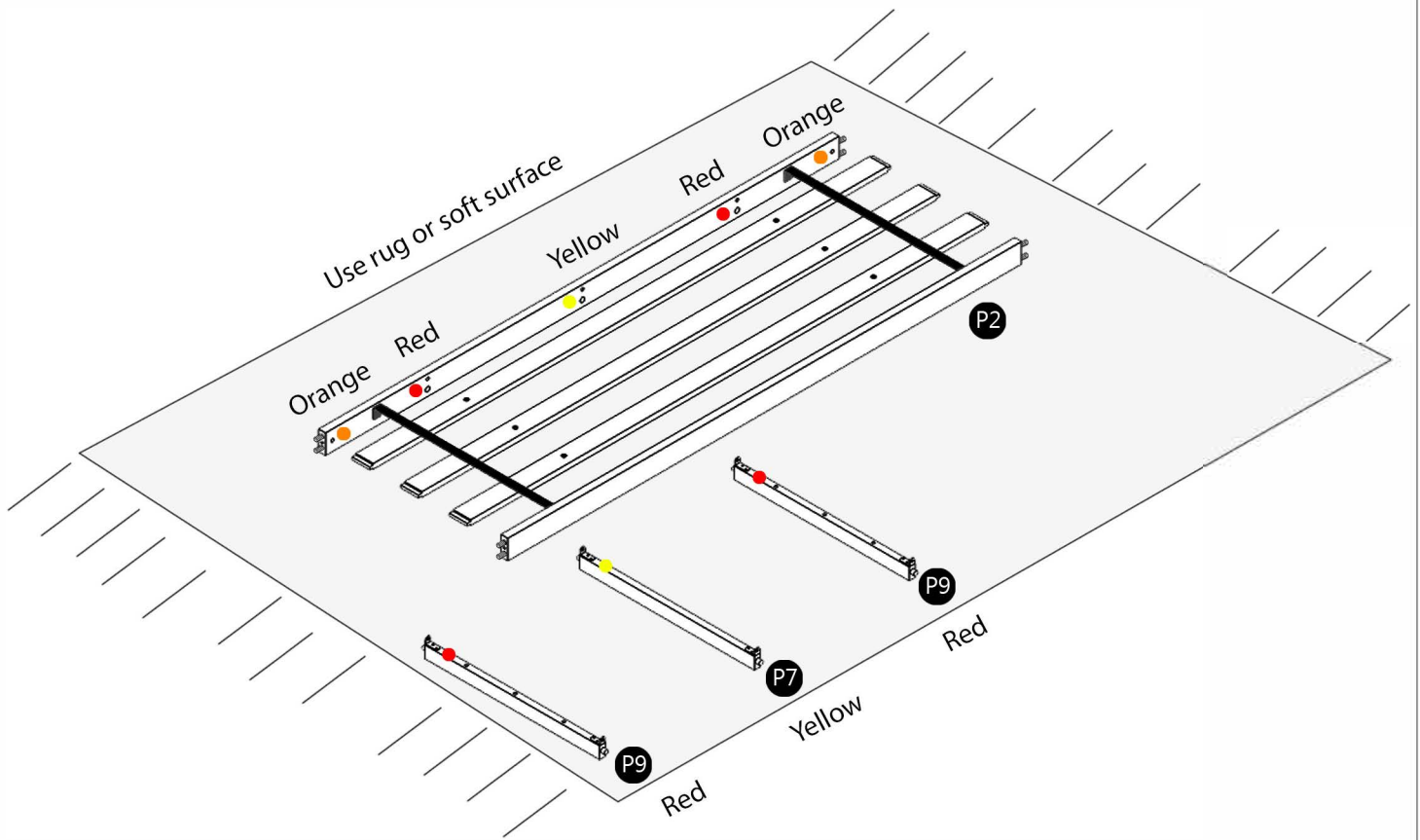

Yellow



P7 & Side View
x 1

Red

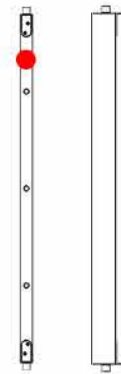

P9 & Side View
x 2

Step 2: Attach P7 and P9(2) to P2 with hardware as shown

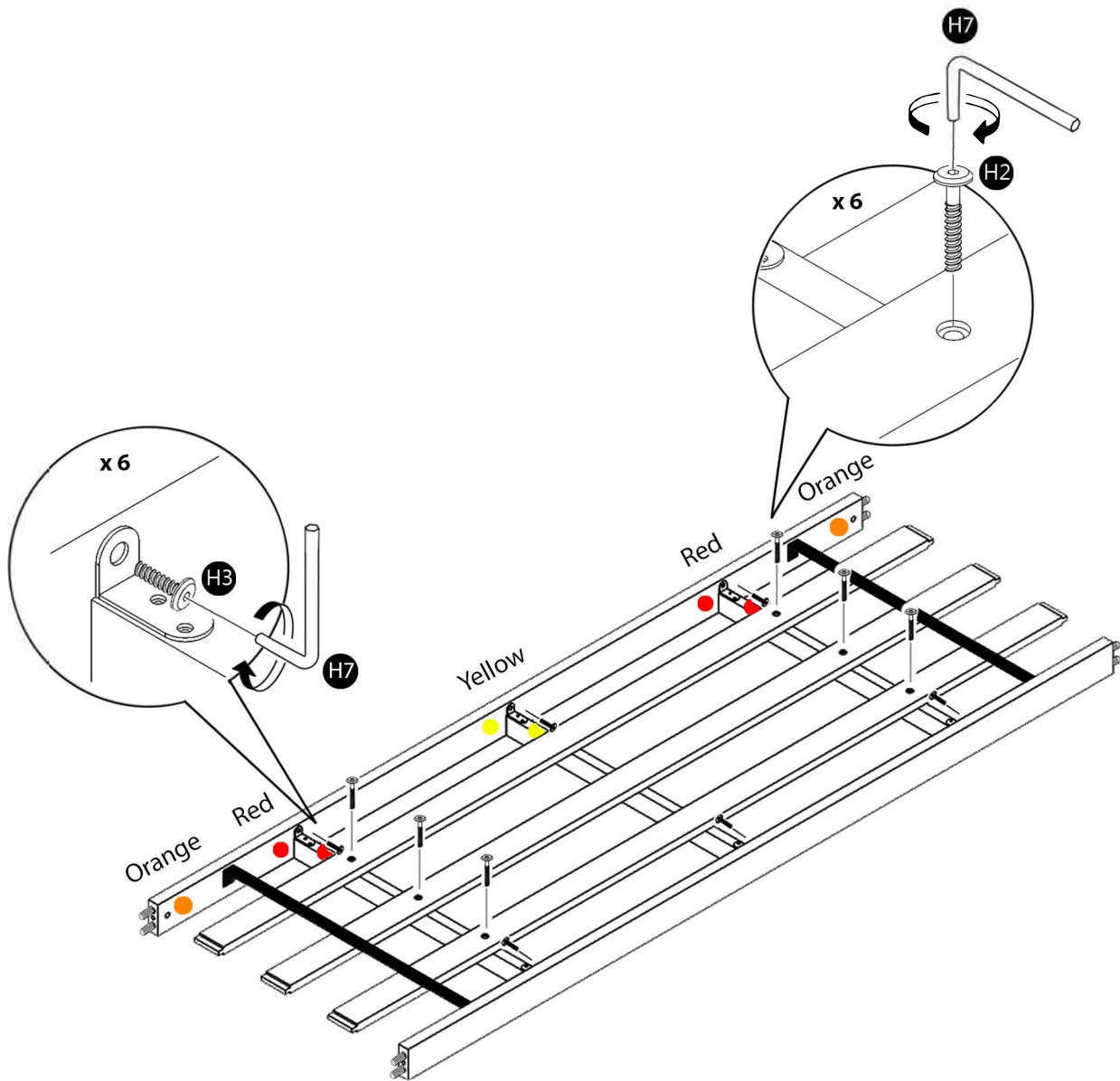

Loosely attach H2 and H3 bolts.

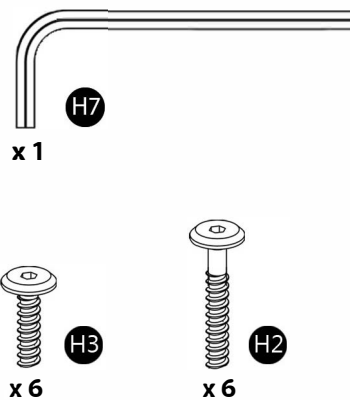

Step 3: Attach four nylon guides (H6) as shown

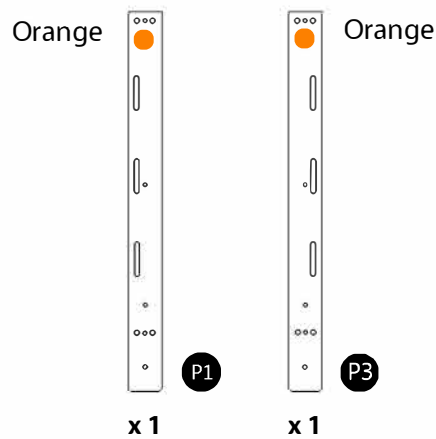
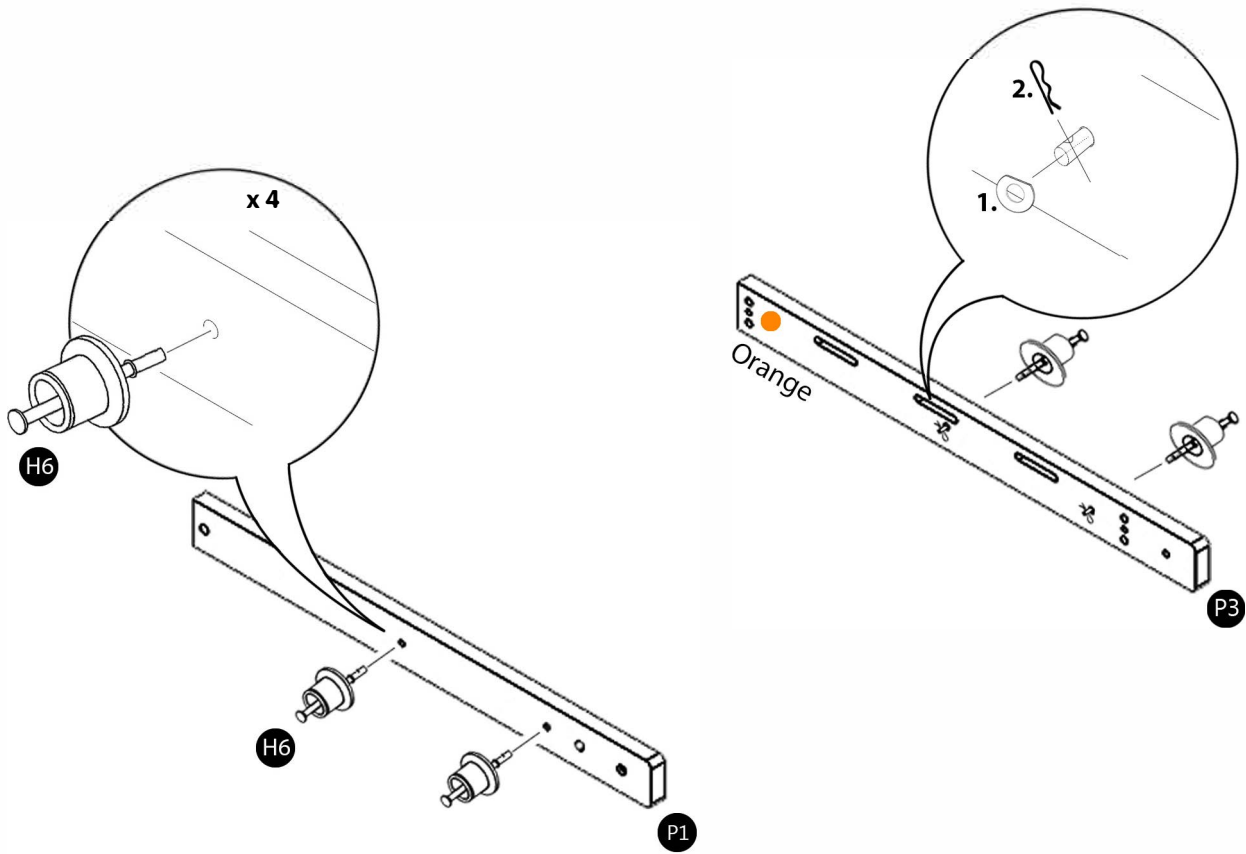

Step 4: Attach P1 & P3 to back deck P2

Use colored dots to align parts for connection.

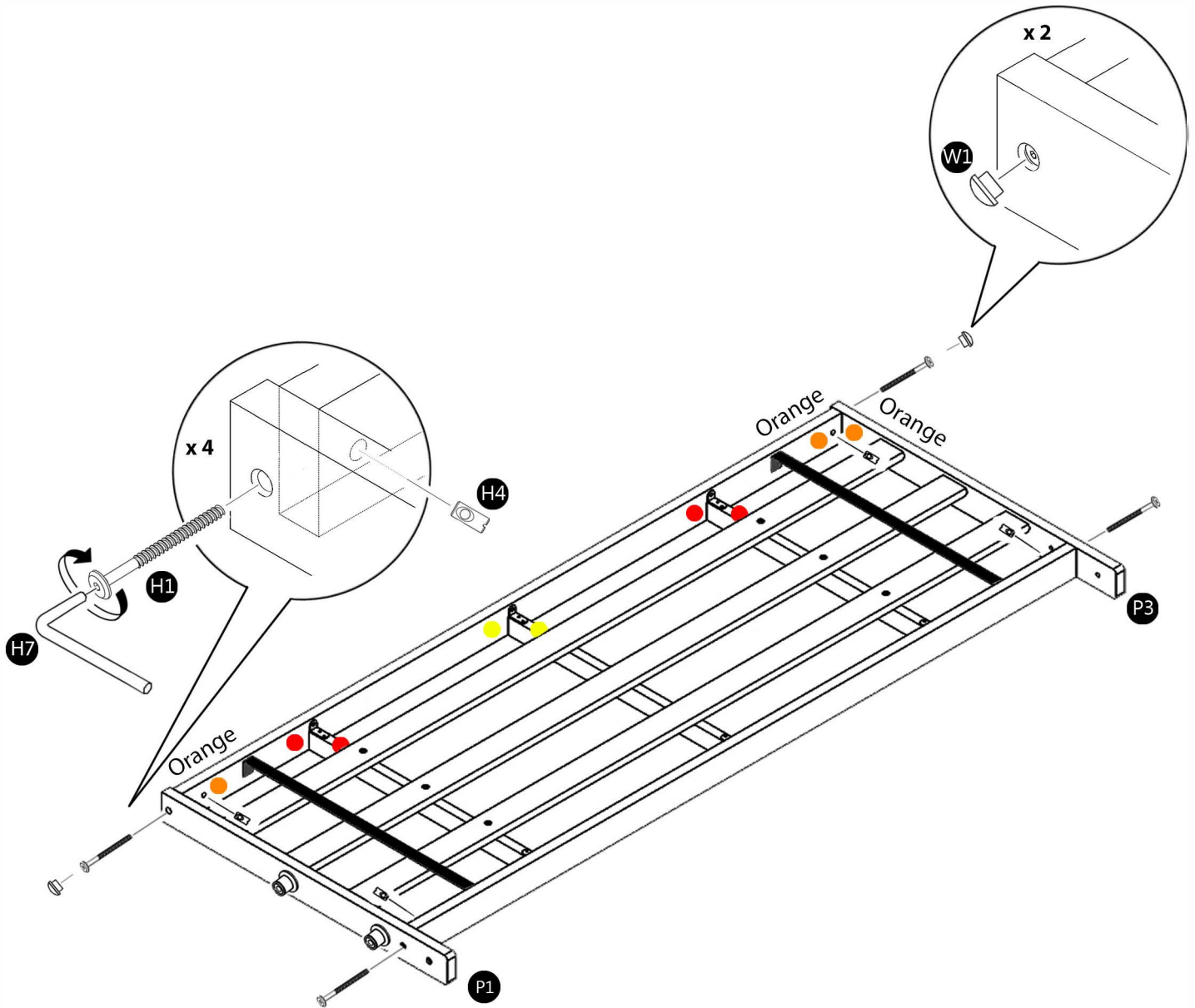

All bolts can be tightened at this point.

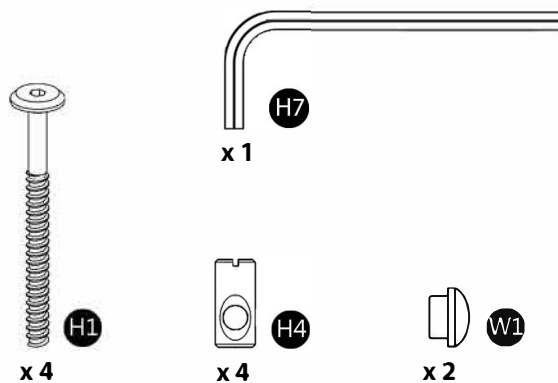

Step 5: Locate parts P5, P8(2), & P7

Use colored dots to align parts for connection.

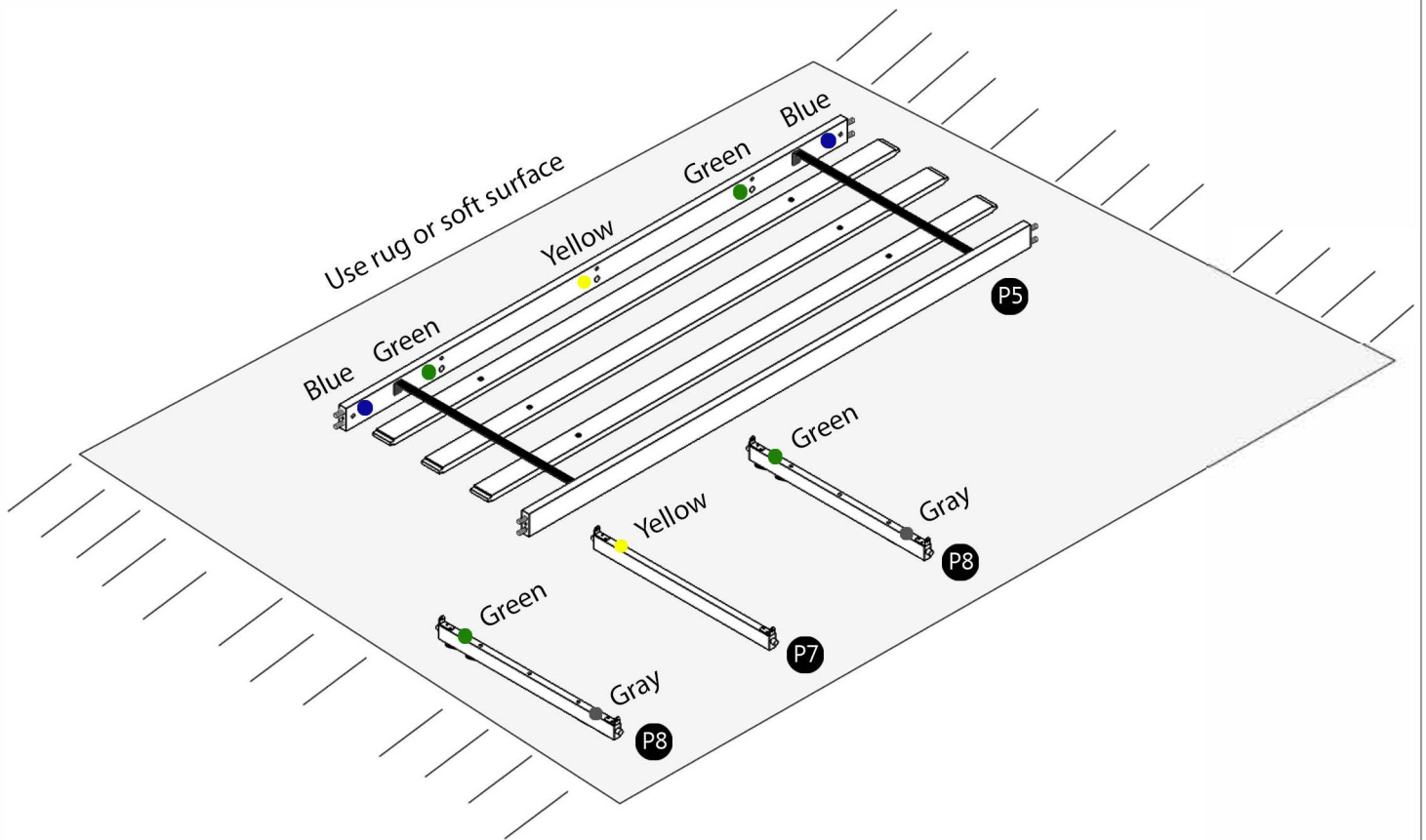

Yellow

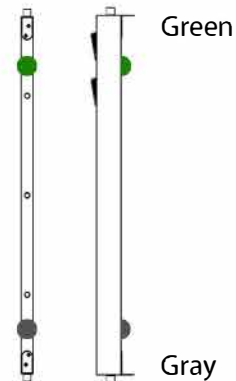
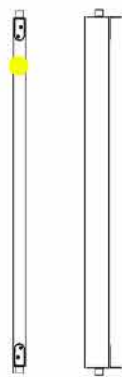

Step 6: Attach P7 and P8(2) to P5 with hardware as shown

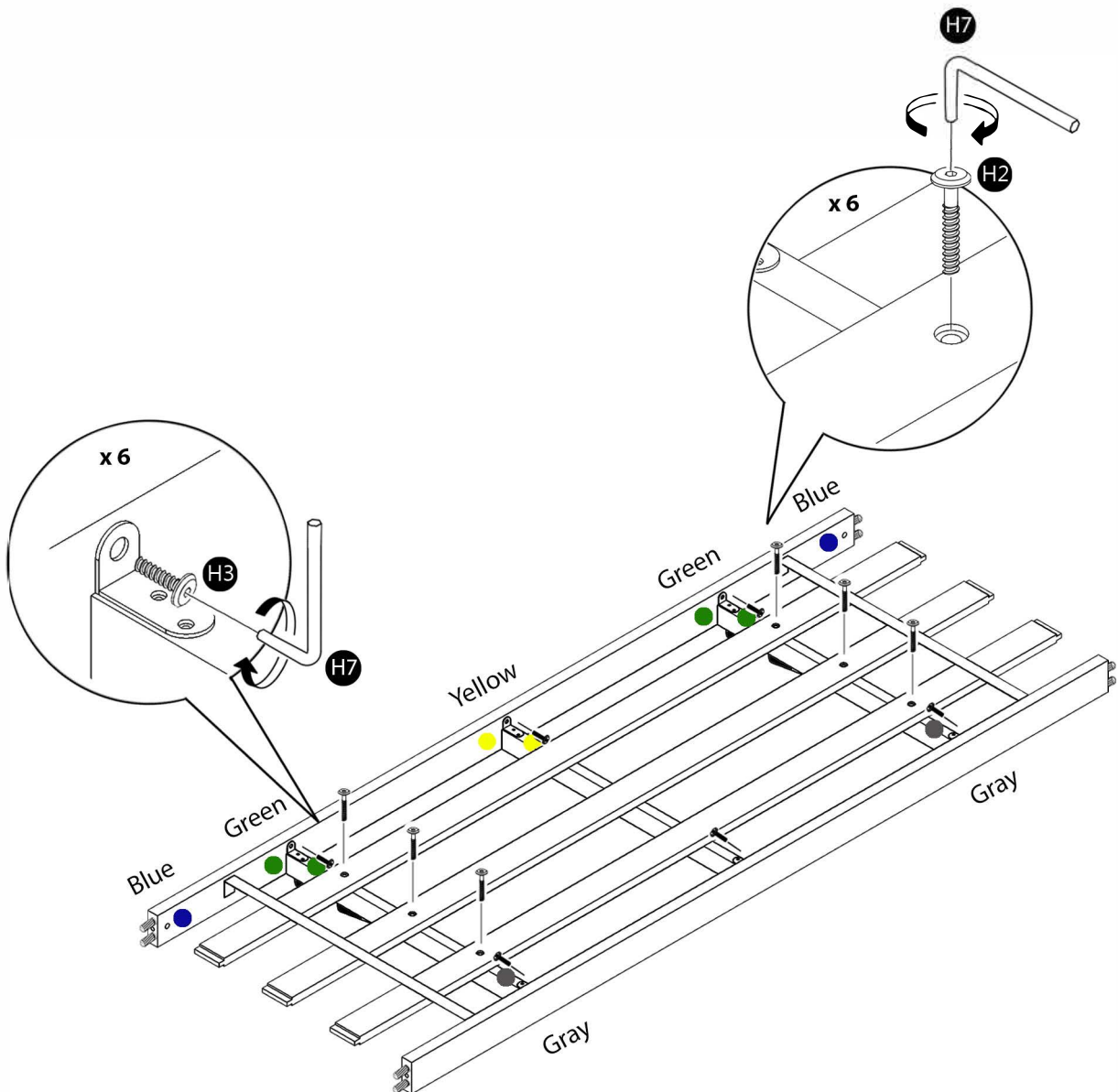

Loosely attach H2 and H3 bolts.

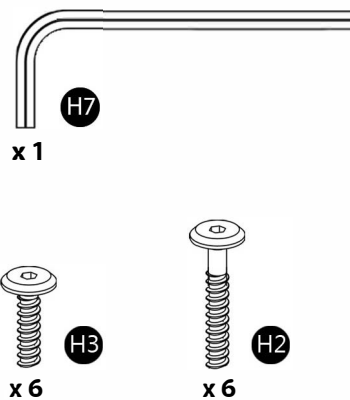

Step 7: Attach P4 & P6 to seat deck P5

Use colored dots to align parts for connection.

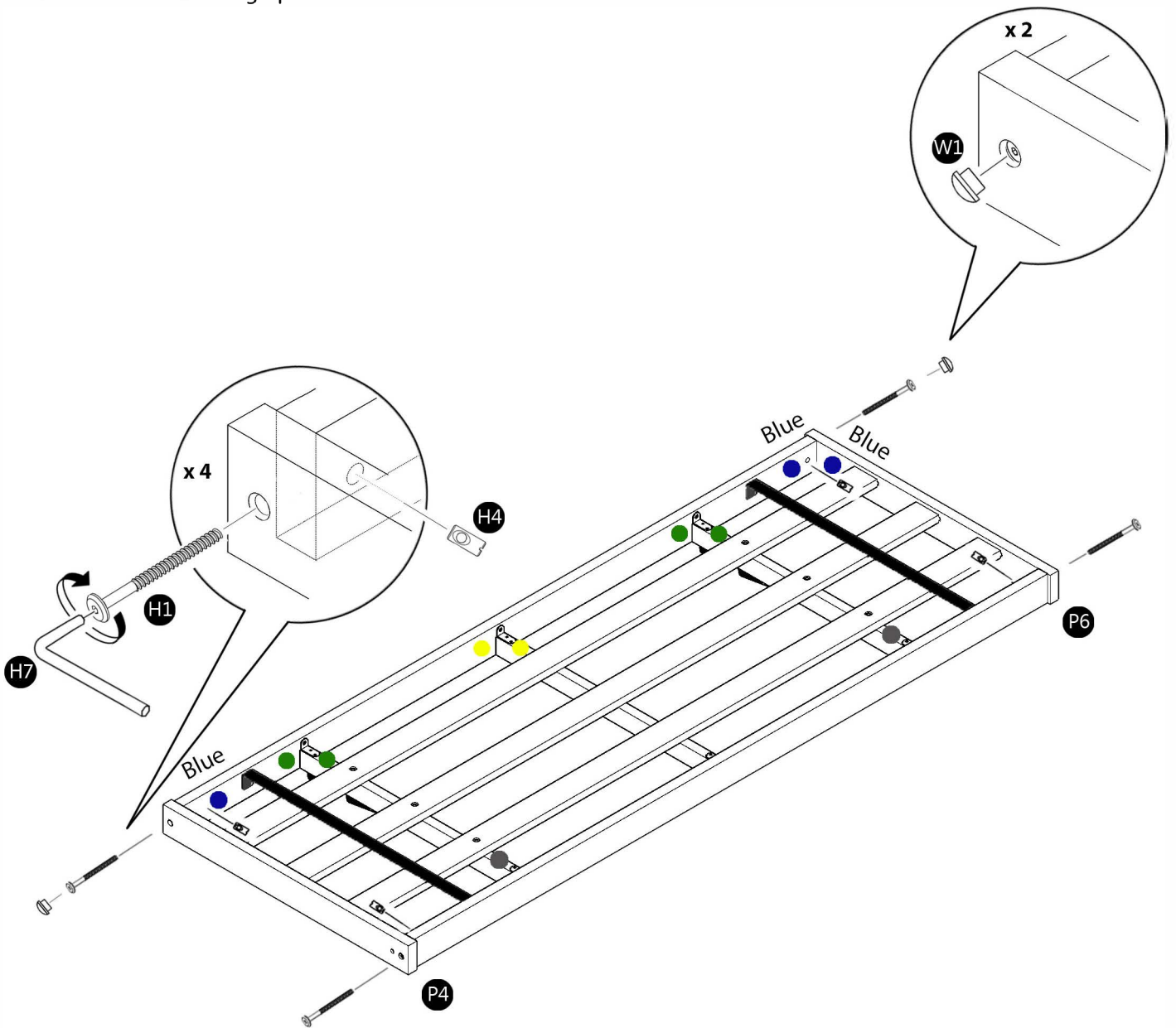

All bolts can be tightened at this point.

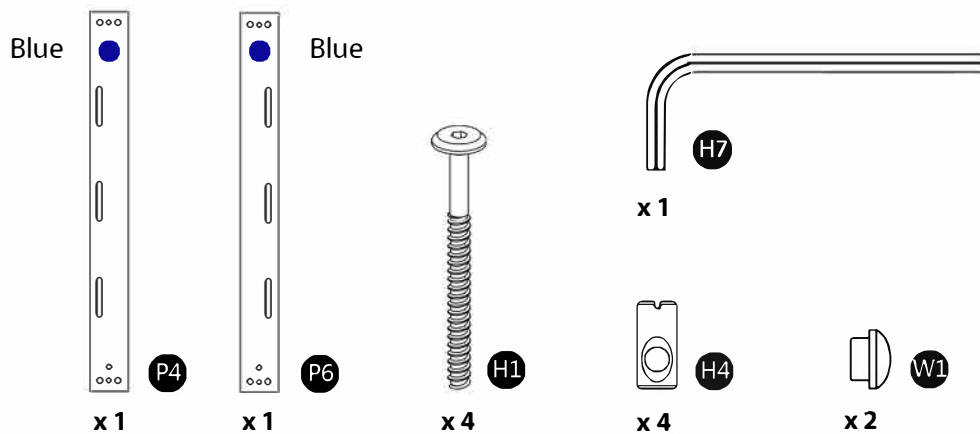

Step 8: Connect the fully assembled seat and back decks using hardware H5 (x2) as shown below

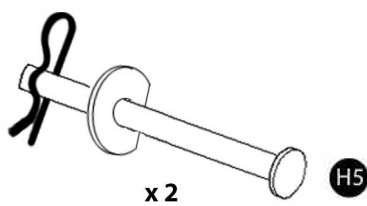
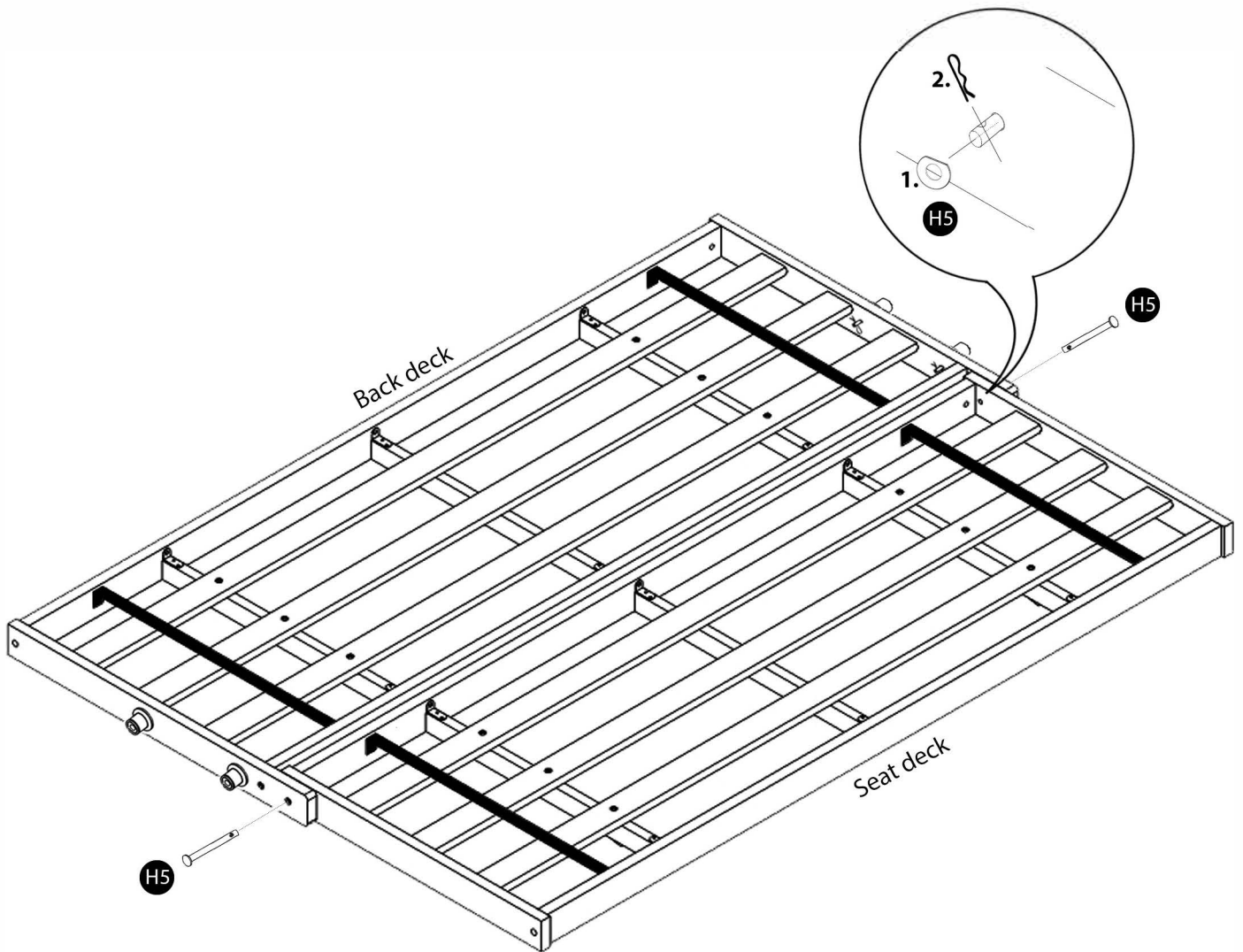

Assembly Checklist

Please make sure that you have all of the below items before you start. If any are missing, please contact us for a replacement.



Arms

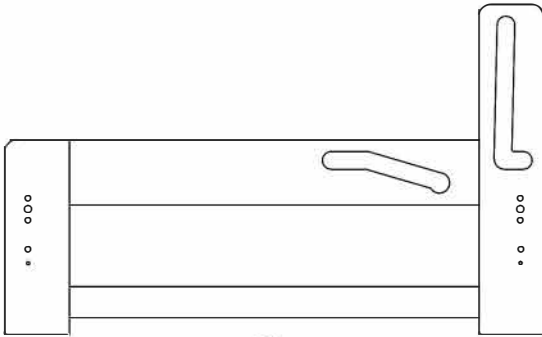

A1

Inside View (Left Side)

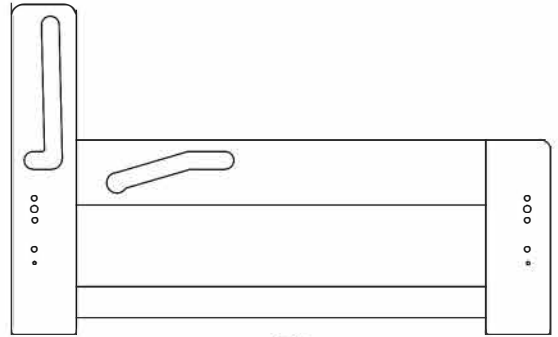

A2

Inside View (Right Side)

Hardware supplied for arm assembly

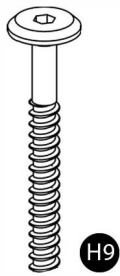

x 8



x 4



x 4



x 8



x 1

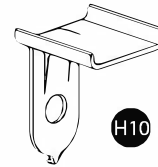

x 4

Step 9: Locate 4 legs, parts A1 & A2

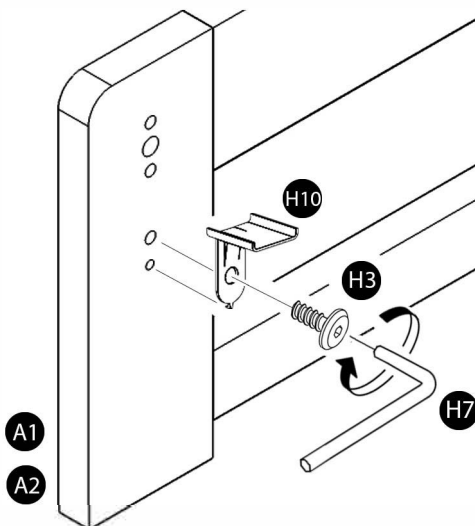

A1

A2



x 4



x 4



x 1

Do not tighten the bolts before finishing all steps.

Step 10: Insert wood dowels (W2) into stretchers (P10) and (P11) as shown

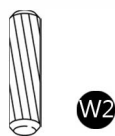
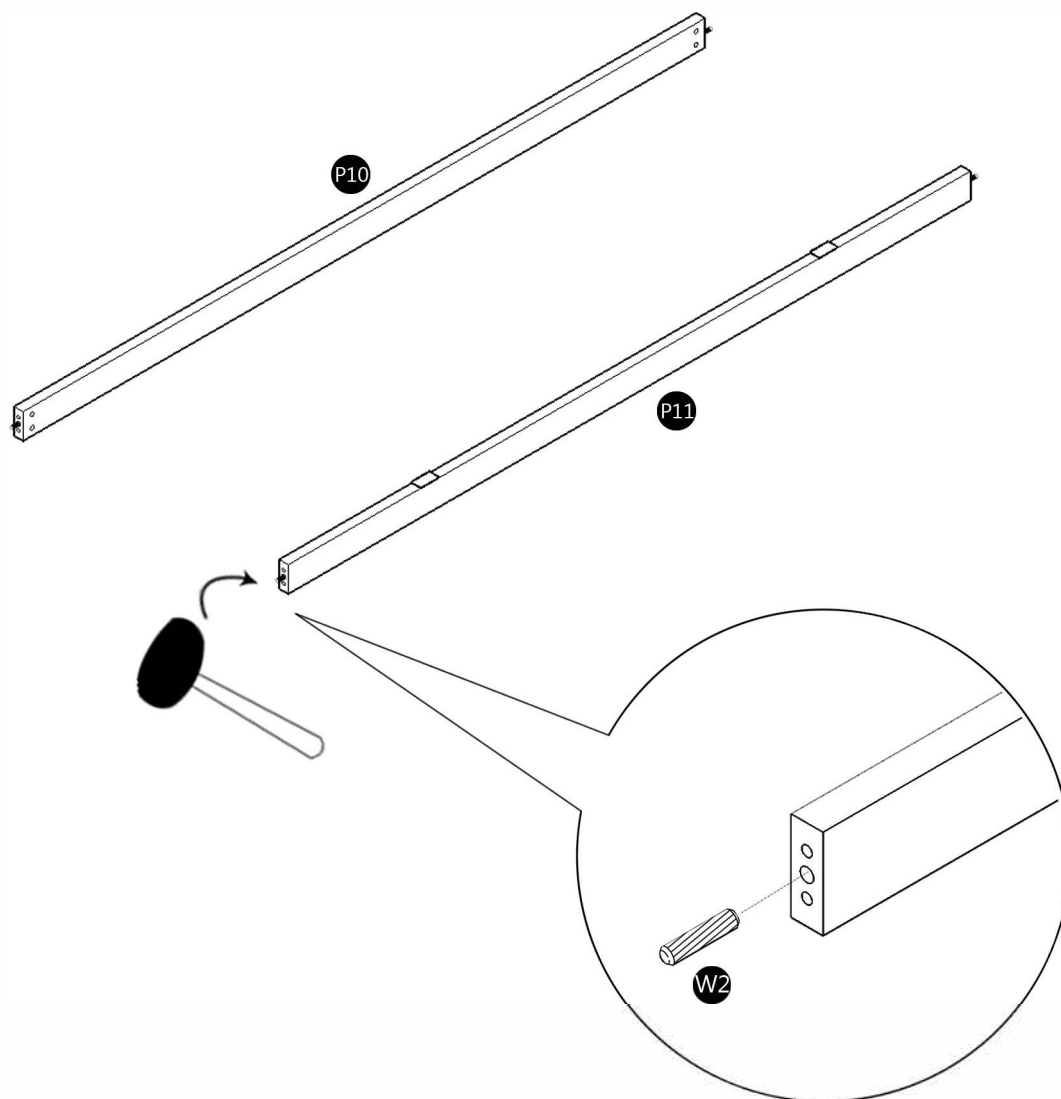

x 4

Step 11: Attach P10 & P11 to A1 & A2 with hardware as shown

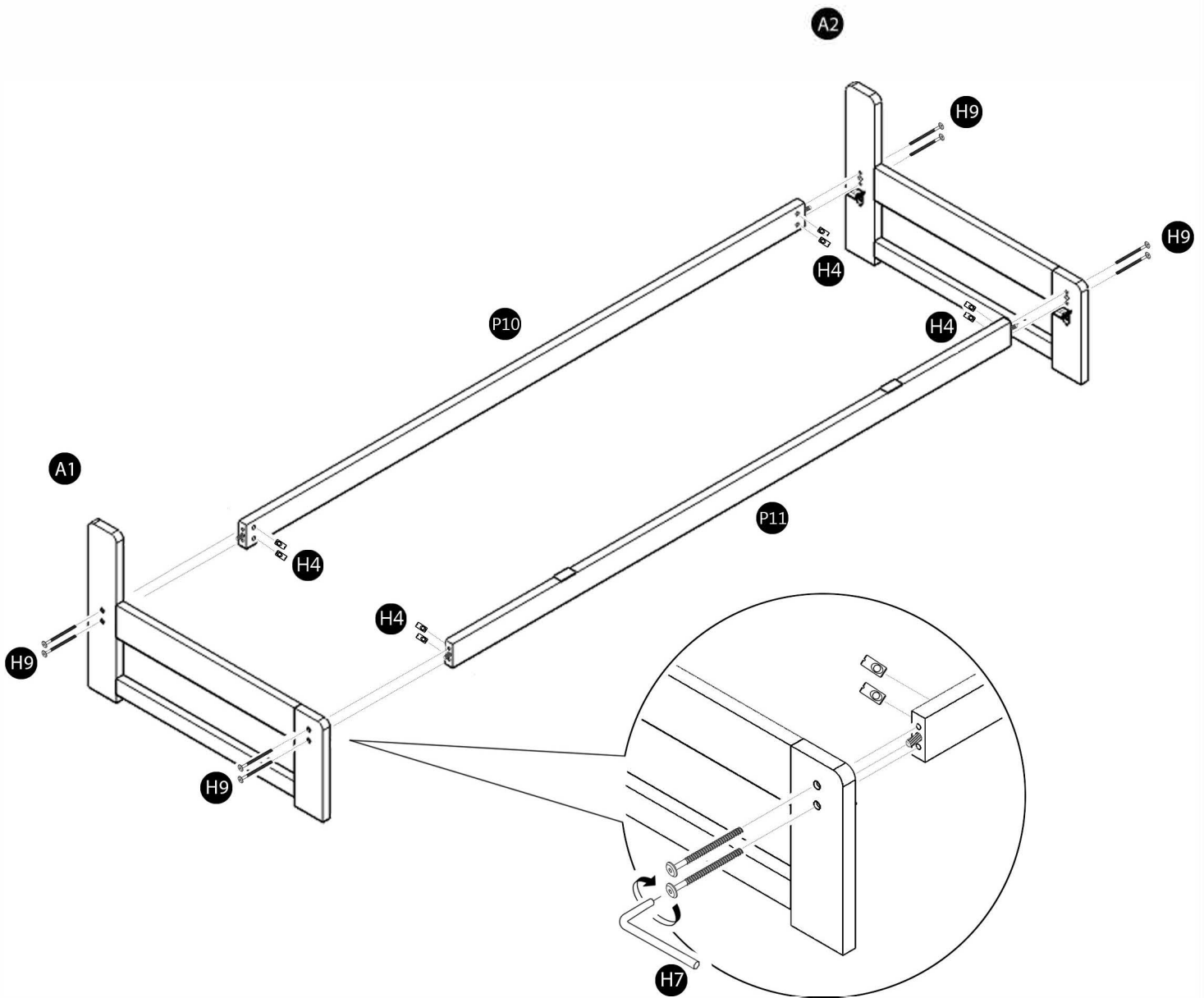

The bolts need to be very loosely attached at this point. Your arm may vary.



H9
x 8



H4
x 8



H7
x 1

Step 12: Align H6(4) into grooved out slots on A1 & A2.

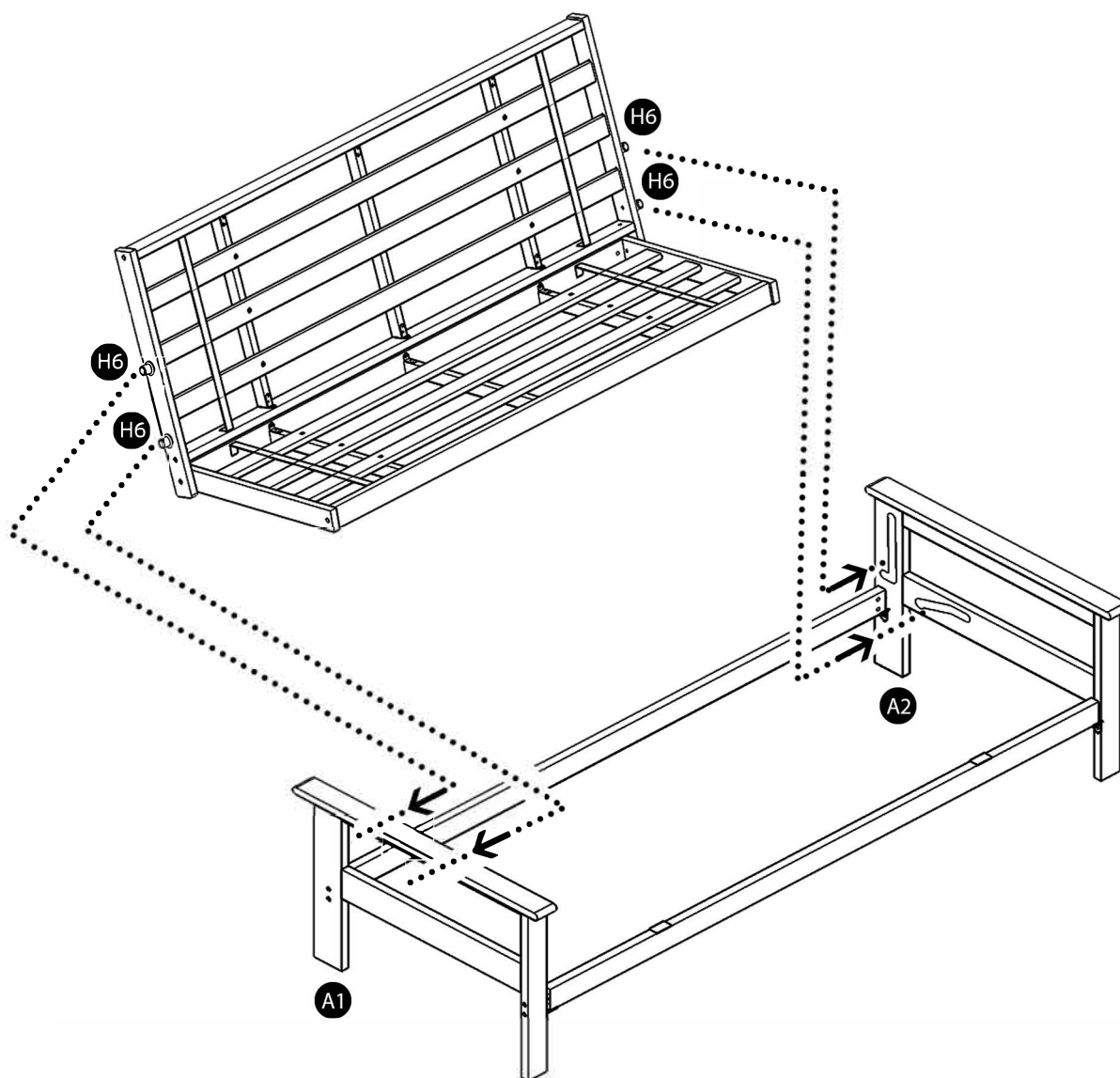

The bolts need to be very loosely attached at this point. Tighten all bolts after everything is in place.



H7

x 1

Assembled views

Your arm may vary.

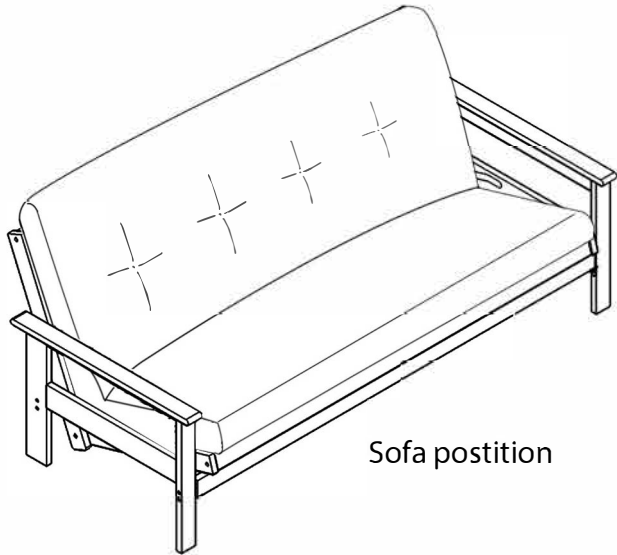

Sofa position

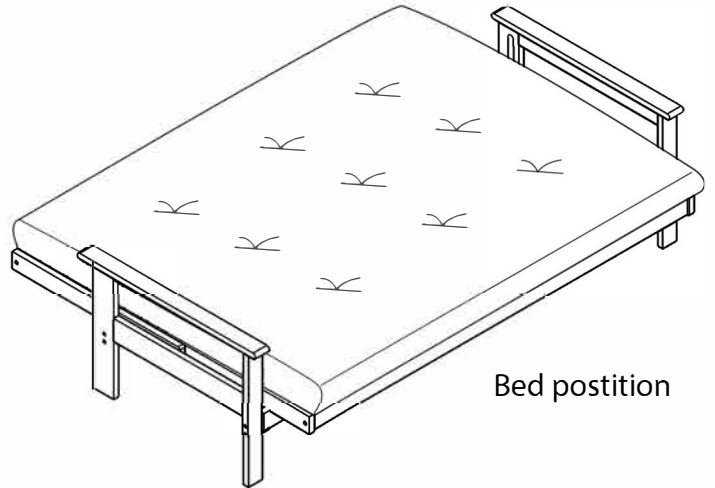

Bed position

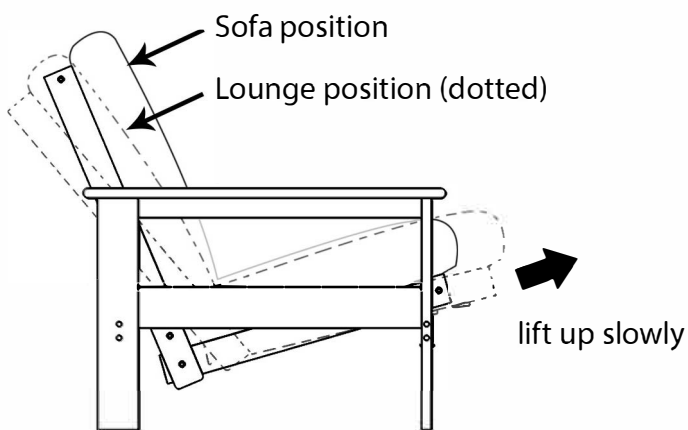

Sofa position to Lounge position.

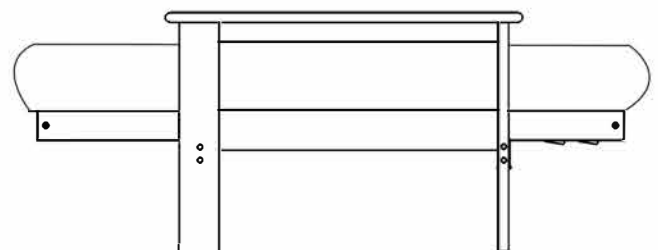

Bed position