

ASSEMBLY INSTRUCTION



Notice:

1. 50% Tighten before fixing all screws, Allen wrench is recommended instead of an electric drill.
2. Place the item on a flat ground to adjust and make sure it remains stable.
3. Tighten up all screws with tools gradually.
4. If the screws are not aligned with holes during assembly, please loosen all the other screws to 50% and continue the assembly process.
5. If the item is not stable, please loosen all the screws, adjust it on a flat ground and tighten up all screws again.
6. Note : If one or some screws are fully tightened during assembly, chances are the others will not be aligned with holes. In addition, all the holes are designed to be relatively larger to provide more space for the adjustment of the screws.

PART LIST AND HARDWARE LIST

A

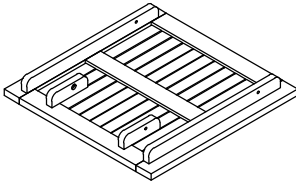

Table Top (1 Pc)

B

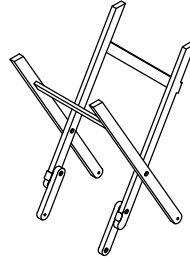
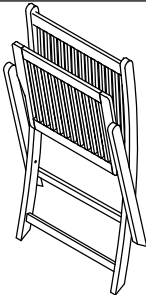

Table Leg (1 Pc)

C



Chair (2 Pcs)

D

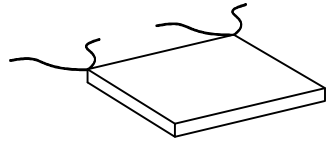

Chair Cushion (2 Pcs)

1

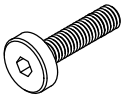

Allen Bolt M6 x 30mm
(4 Pcs)

2

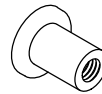

Nut M6 x 15mm
(4 Pcs)

3

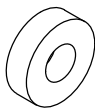

Washer M6 x 2mm
(4 Pcs)

4



Allen Key (2 Pcs)

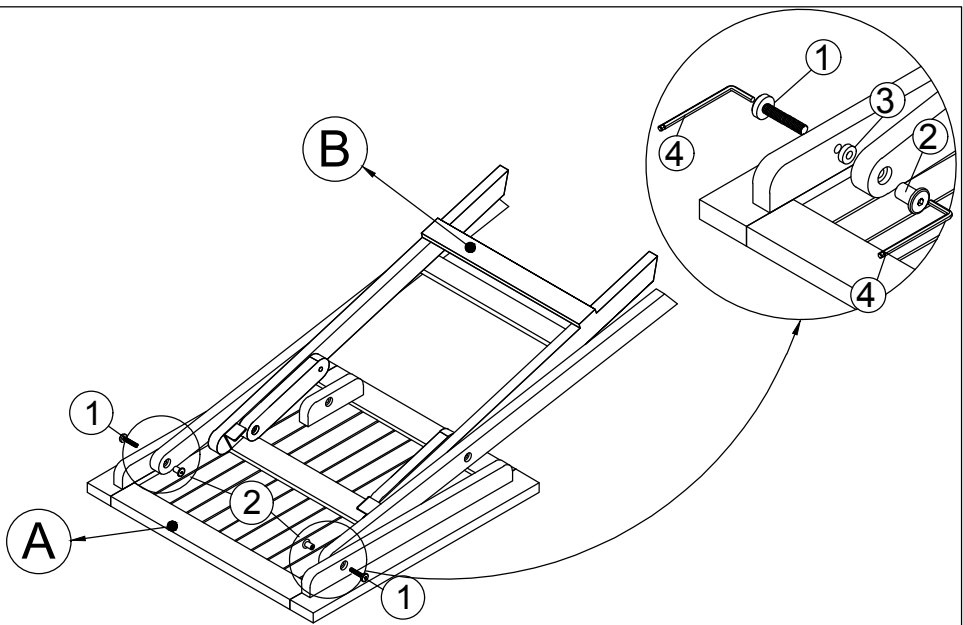

Ax1 Bx1 1x2 2x2 3x2

STEP 1: Connect Top Table (A) & Leg Table (B), tighten Bolt (1), Washer (3) & Nut (2) with Allen Key (4).

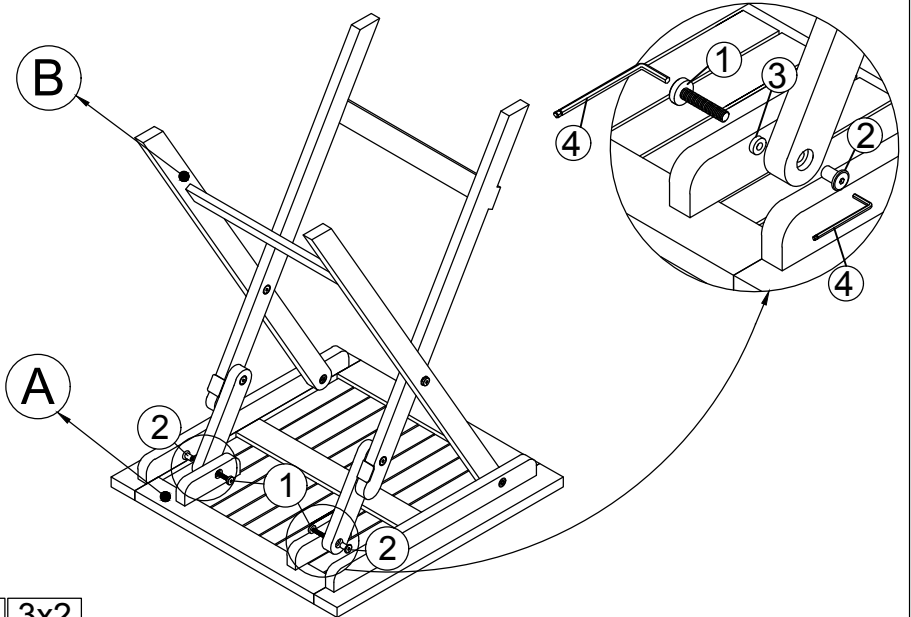

1x2 2x2 3x2

STEP 2: Connect The Part from Step 1, tighten Bolt (1), Washer (3) & Nut (2) with Allen Key (4).

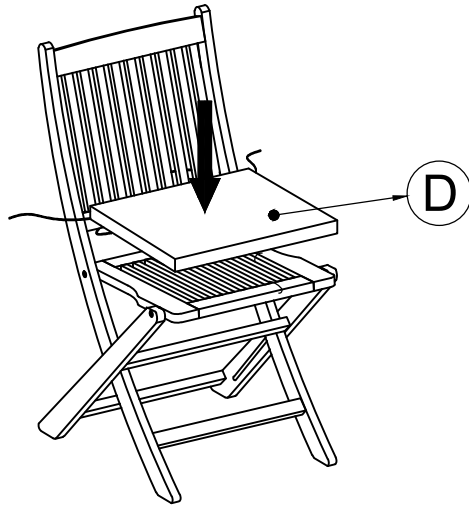

Dx2

STEP 3: Úut the Chair (CDu] ri* ht & Úut on Chair Cushion (ÖD

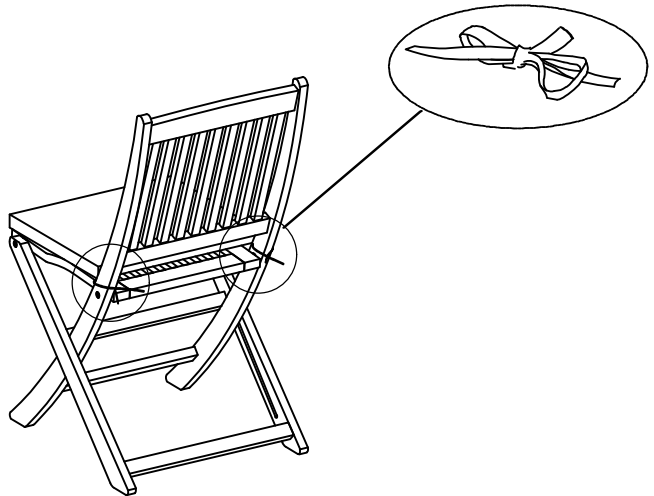

STEP I : the Chair is reaã^ to àe useã.

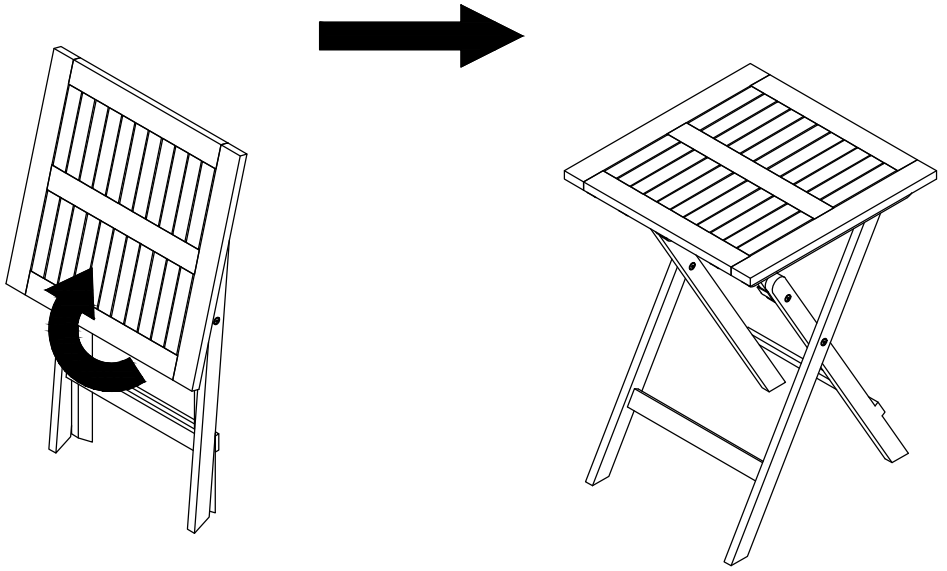

OPEN TABLE

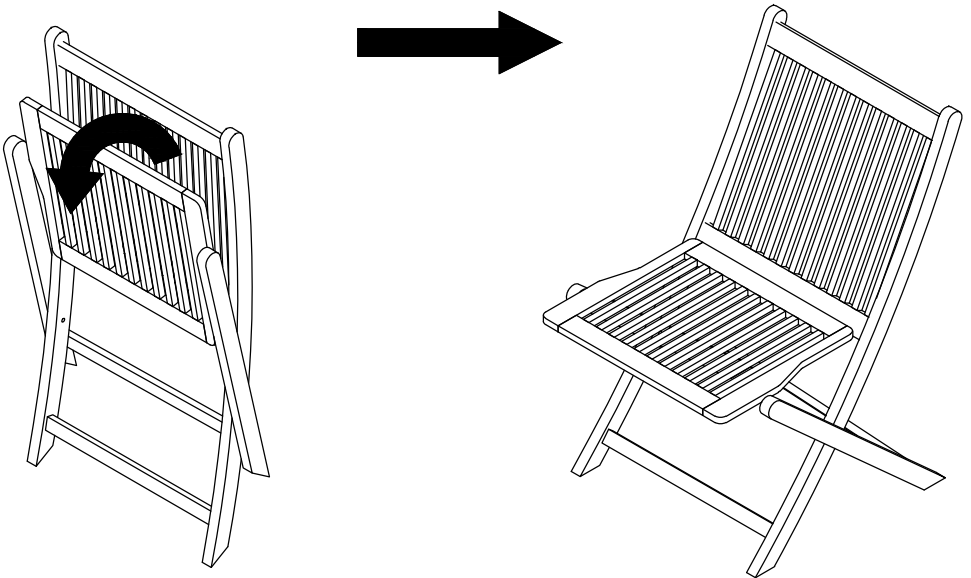

OPEN CHAIR

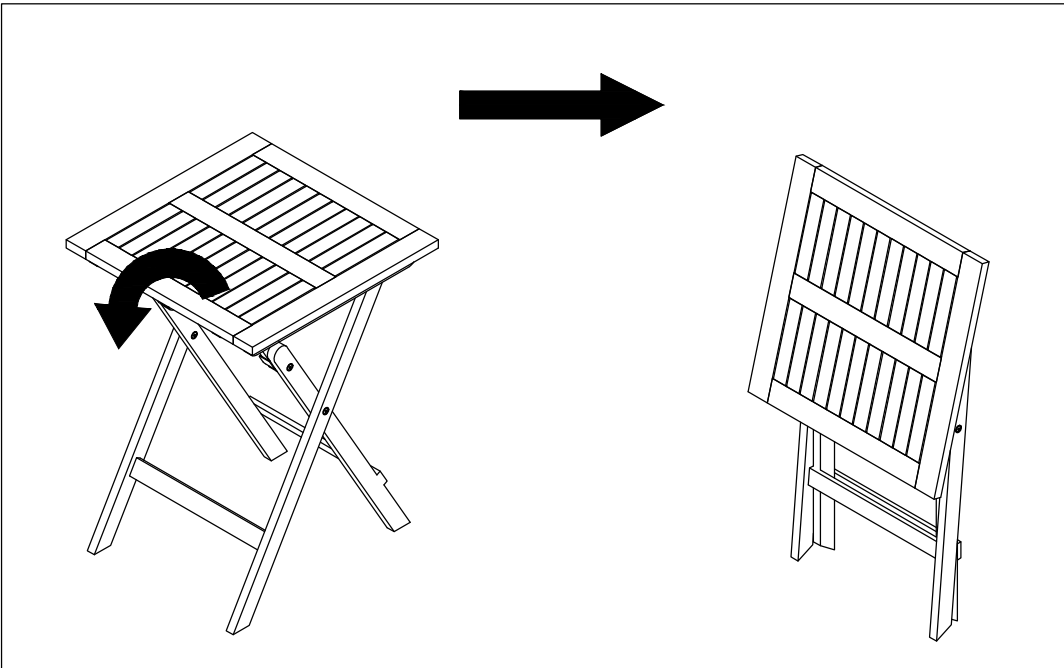

FOLD TABLE

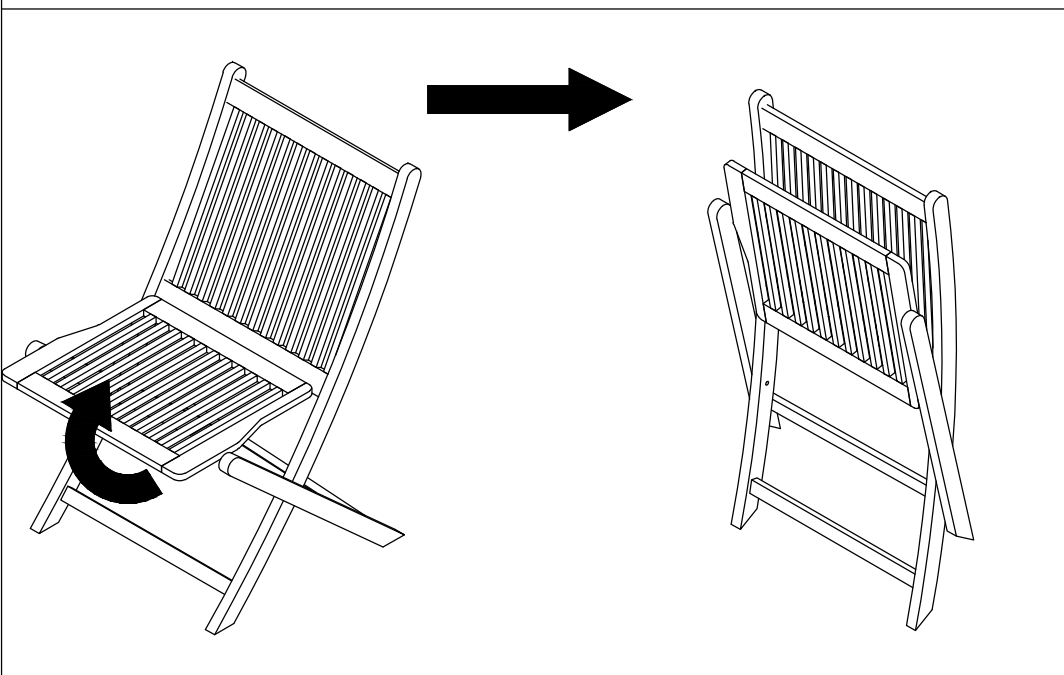

FOLD CHAIR