

ROOM AIR CONDITIONER

USER MANUAL

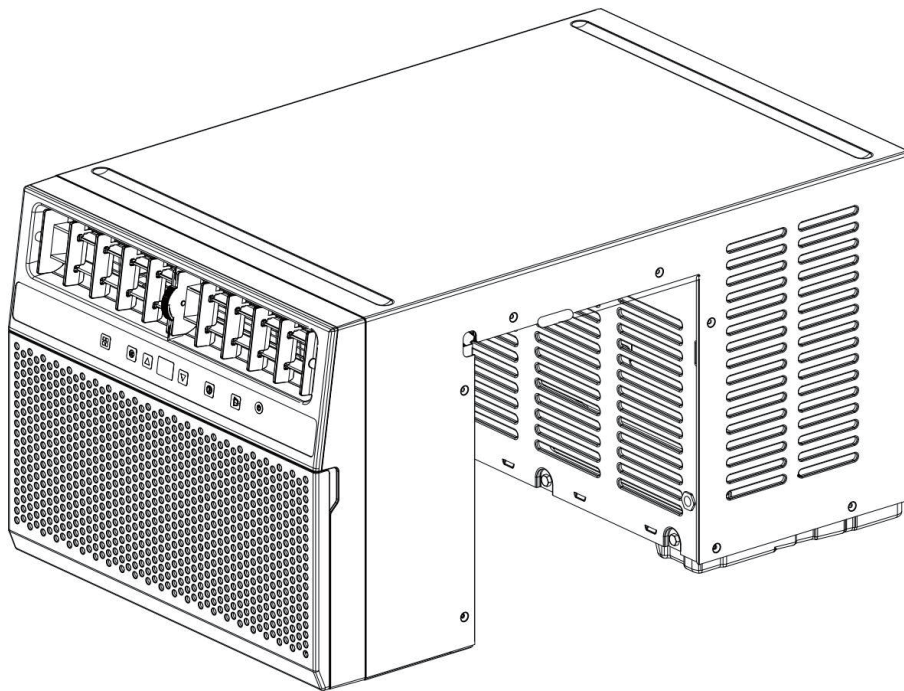

**Model No.: NCAA-06C/X1E
NCAA-08C/X1E**

**ITEM NO.: A5416W-10K-EL
A5418W-12K-EL**

Read this booklet thoroughly before using and save it for future reference



Scan the QR code to watch the product videos

 **Web:** www.electacticshop.com

 **Email:** service@electacticshop.com

 **Tel:** 888-698-2504

CONTENTS

SAFETY INSTRUCTION	1
PARTS IDENTIFICATION	8
INSTALLATION REQUIREMENTS	9
INSTALLATION INSTRUCTIONS	11
STEP 1 - UNPACK AIR CONDITIONER	11
STEP 2 - ATTACH MOUNTING BLOCKS ON WINDOW FRAME	11
STEP 3 - SLIDE ROOM AIR CONDITIONER OVER WINDOW SILL	11
STEP 4 - ADJUST THE SUPPORT KNOB	11
STEP 5 – ATTACH FOAM SEALER	12
STEP 6 – ATTACH TOP FOAM SEALER	12
STEP 7 – INSTALLATION COMPLETE	12
CONTROL PANEL	13
BUTTONS	13
REMOTE CONTROL	14
DRAIN THE INTERNAL WATER	16
INDOOR DRAINAGE	16
SAFETY PROTECTIONS	16
CARE AND MAINTENANCE	16
SURFACE CLEANING	16
FILTER CLEANING	17
END OF SEASON	17
TROUBLESHOOTING	18

SAFETY INSTRUCTION

Your safety and the safety of others are very important.



We have provided many important safety messages in this manual and on your appliance. Always read and obey all safety messages.



This is the safety alert symbol.

This symbol alerts you to potential hazards that can hurt you and others. All safety messages will follow the safety alert symbol, either the word "DANGER," "WARNING" or "CAUTION."

These words mean:

 DANGER	An imminently hazardous situation. You could be killed or seriously injured if you don't immediately follow instructions.
 WARNING	A potentially hazardous situation which, if not avoided, could result in death or serious bodily injury.
 CAUTION	A potentially hazardous situation which, if not avoided, may result in moderate or minor injury.

All safety messages will tell you what the potential hazard is, tell you how to reduce the chance of injury, and tell you what can happen if the instructions are not followed.

IMPORTANT SAFETY INSTRUCTIONS



A2L

Caution: risk of fire warning;
Flammable materials
Attention : risque
d'avertissement d'incendie ;
Matériaux inflammables



Read operator'
Manual
Lire l'opérateur'
Manuel



operator' manual;
operating instructions
manuel de l'opérateur ;
mode d'emploi

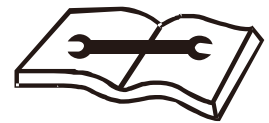

service indicator;
read technical manual
indicateur de service;
lire technique Manuel

WARNING-RISK OF FIRE OR EXPLOSION-STORE IN A WELL VENTILATED ROOM WITHOUT CONTINUOUSLY OPERATING FLAMES OR OTHER POTENTIAL IGNITION.

WARNING: To reduce the risk of fire, electrical shock, injury to persons, or damage when using the air conditioner, follow basic precautions, including the following:

- Appliance shall be stored in a well-ventilated area where the room size is not less than 4 m².
- Read all of the instructions before using this appliance.
- Plug into a grounded 3 prong outlet.
- Do not remove ground prong.
- Do not use an adapter.
- Do not use an extension cord.
- Do not operate the air conditioner if it has a damaged cord or plug, if it is not working properly, or if it has been damaged or dropped.
- The air conditioner should be serviced only by qualified service personnel. Call an authorized service company for examination, repair, or adjustment.

- Disconnect power before servicing.
- Disconnect power before cleaning.
- **NOTE:** Turning off power by pressing the Power button does NOT disconnect the appliance from the power supply.
- Do not install or use the air conditioner in any area where the atmosphere contains combustible gases or where the atmosphere is contaminated. Avoid any chemicals coming in contact with your air conditioner.
- Do not store anything directly on top of the air conditioner.
- The appliance can be used by children over the age of 8 and persons with reduced physical, sensory or mental capabilities if they have been given supervision or instruction concerning use of the appliance in a safe way and understand the hazards involved. Children shall not play with the appliance. Cleaning and maintenance shall not be made by children without supervision.
- This appliance is not intended for use by persons (including children) with reduced physical, sensory or mental capabilities, or lack of experience and knowledge, unless they have been given supervision or instruction concerning use of the appliance by a person responsible for their safety. Children should be supervised to ensure that they do not play with the appliance.
- Use two or more people to move and install air conditioner.
- Never operate the air conditioner without the filters in place.
- Do not use the air conditioner near a bathtub, shower or wash basin or other wet areas.
- Do not use means to accelerate the defrosting process or to clean, other than those recommended by the manufacturer.
- The appliance shall be stored in a room without continuously operating ignition sources (for example: open flames, an operating gas appliance or an operating electric heater. Do not pierce or burn.
- Be aware that refrigerants may not contain an odor.
 - the maximum refrigerant charge amount: NCAA-06C/X1E - 8.82Oz
NCAA-08C/X1E - 9.88Oz
- The appliance shall be stored so as to prevent mechanical damage from occurring.
- Any person who is involved with working on or breaking into a refrigerant circuit should hold a currently valid certificate from an industry-accredited assessment authority, which authorizes their competence to handle refrigerants safely in accordance with industry recognized assessment specification. Servicing shall only be performed as recommended by the equipment manufacturer. Maintenance and repair requiring the assistance of other skilled personnel shall be carried out under the supervision of the person competent in the use of flammable refrigerants.
- Prior to beginning work on systems containing flammable refrigerants, safety checks are necessary to ensure that the risk of ignition is minimized. Work shall be undertaken under a controlled procedure so as to minimize the risk of a flammable gas or vapor being present while the work is being performed. All maintenance staff and others working in the local area shall be instructed on the nature of work being carried out. Work in confined spaces shall be avoided. The area around the workspace shall be sectioned off. Ensure that the conditions within the area have been made safe by control of flammable material.
- The area shall be checked with an appropriate refrigerant detector prior to and during work, to ensure the technician is aware of potentially flammable atmospheres. Ensure that the leak detection equipment being used is suitable for use with flammable refrigerants, i.e. no sparking, adequately sealed or intrinsically safe.
- If any hot work is to be conducted on the refrigeration equipment or any associated parts, appropriate fire extinguishing equipment shall be available to hand. Have a dry powder or CO² fire extinguisher adjacent to the charging area.
- No person carrying out work in relation to a refrigeration system which involves exposing any pipe work that contains or has contained flammable refrigerant shall use any sources of ignition in such a manner that it may lead to the risk of fire or explosion. All possible ignition sources, including cigarette smoking, should be kept sufficiently far away from the site of installation, repairing, removal and disposal, during which flammable refrigerant can possibly be released to the surrounding space. Prior to work taking place, the area around the equipment is to be surveyed to make sure that there are no flammable hazards or ignition risks. "No Smoking" signs shall be displayed.
- Ensure that the area is in the open or that it is adequately ventilated before breaking into the system or conducting any hot work. A degree of ventilation shall continue during the period that the work is carried out. The ventilation should safely disperse any released refrigerant and preferably expel it externally into the atmosphere.

- Do not apply any permanent inductive or capacitance loads to the circuit without ensuring that this will not exceed the permissible voltage and currently permitted for the equipment in use. Intrinsically safe components are the only types that can be worked on while living in the presence of a flammable atmosphere. The test apparatus shall be at the correct rating. Replace components only with parts specified by the manufacturer. Other parts may result in the ignition of refrigerant in the atmosphere from a leak.
- Check that cabling will not be subject to wear, corrosion, excessive pressure, vibration, sharp edges or any other adverse environmental effects. The check shall also take into account the effects of aging or continual vibration from sources such as compressors or fans.
- Under no circumstances shall potential sources of ignition be used in the search for or detection of refrigerant leaks. A halide torch (or any other detector using a naked flame) shall not be used.
- Electronic leak detectors shall be used to detect flammable refrigerants, but the sensitivity may not be adequate, or may need re-calibration. (Detection equipment shall be calibrated in a refrigerant-free area.) Ensure that the detector is not a potential source of ignition and is suitable for the refrigerant used. Leak detection equipment shall be set at a percentage of the LFL of the refrigerant and shall be calibrated to the refrigerant employed and the appropriate percentage of gas (25 % maximum) is confirmed. Leak detection fluids are suitable for use with most refrigerants but the use of detergents containing chlorine shall be avoided as the chlorine may react with the refrigerant and corrode the copper pipe-work. If a leak is suspected, all naked flames shall be removed/extinguished. If a leakage of refrigerant is found which requires brazing, all of the refrigerant shall be recovered from the system, or isolated (by means of shut off valves) in a part of the system remote from the leak. Oxygen free nitrogen (OFN) shall then be purged through the system both before and during the brazing process.
- When breaking into the refrigerant circuit to make repairs – or for any other purpose – conventional procedures shall be used. However, it is important that best practice is followed since flammability is a consideration. The following procedure shall be adhered to:
 - remove refrigerant;
 - purge the circuit with inert gas;
 - evacuate;
 - purge again with inert gas;
 - open the circuit by cutting or brazing.
- The refrigerant charge shall be recovered into the correct recovery cylinders. The system shall be “flushed” with OFN to render the unit safe. This process may need to be repeated several times. Compressed air or oxygen shall not be used for this task. Flushing shall be achieved by breaking the vacuum in the system with OFN and continuing to fill until the working pressure is achieved, then venting to the atmosphere, and finally pulling down to a vacuum. This process shall be repeated until no refrigerant is within the system. When the final OFN charge is used, the system shall be vented down to atmospheric pressure to enable work to take place. This operation is absolutely vital if brazing operations on the pipe-work are to take place. Ensure that the outlet for the vacuum pump is not close to any ignition sources and there is ventilation available.
- In addition to conventional charging procedures, the following requirements shall be followed.
 - Ensure that contamination of different refrigerants does not occur when using charging equipment. Hoses or lines shall be as short as possible to minimize the amount of refrigerant contained in them.
 - Cylinders shall be kept upright.
 - Ensure that the refrigeration system is earthed prior to charging the system with refrigerant.
 - Label the system when charging is complete (if not already).
 - Extreme care shall be taken not to overfill the refrigeration system.
- Prior to recharging the system it shall be pressure tested with OFN. The system shall be leak tested on completion of charging but prior to commissioning. A follow up leak test shall be carried out prior to leaving the site.
- Before carrying out this procedure, it is essential that the technician is completely familiar with the equipment and all its detail. It is recommended good practice that all refrigerants are recovered safely. Prior to the task being carried out, an oil and refrigerant sample shall be taken in case analysis is required prior to re-use of reclaimed refrigerant. It is essential that electrical power is available before the task is commenced.
 - a) Become familiar with the equipment and its operation.
 - b) Isolate system electrically.

- c) Before attempting the procedure ensure that:
 - mechanical handling equipment is available, if required, for handling refrigerant cylinders;
 - all personal protective equipment is available and being used correctly;
 - the recovery process is supervised at all times by a competent person;
 - recovery equipment and cylinders conform to the appropriate standards.
 - d) Pump down refrigerant system, if possible.
 - e) If a vacuum is not possible, make a manifold so that refrigerant can be removed from various parts of the system.
 - f) Make sure that cylinder is situated on the scales before recovery takes place.
 - g) Start the recovery machine and operate it in accordance with the manufacturer's instructions.
 - h) Do not overfill cylinders. (No more than 80 % volume liquid charge).
 - i) Do not exceed the maximum working pressure of the cylinder, even temporarily.
 - j) When the cylinders have been filled correctly and the process completed, make sure that the cylinders and the equipment are removed from site promptly and all isolation valves on the equipment are closed off.
 - k) Recovered refrigerant shall not be charged into another refrigeration system unless it has been cleaned and checked.
- Equipment shall be labeled stating that it has been de-commissioned and emptied of refrigerant. The label shall be dated and signed. Ensure that there are labels on the equipment stating the equipment contains flammable refrigerant.
 - When removing refrigerant from a system, either for servicing or decommissioning, it is recommended good practice that all refrigerants are removed safely. When transferring refrigerant into cylinders, ensure that only appropriate refrigerant recovery cylinders are employed. Ensure that the correct number of cylinders for holding the total system charge are available. All cylinders to be used are designated for the recovered refrigerant and labelled for that refrigerant (i.e. special cylinders for the recovery of refrigerant). Cylinders shall be complete with pressure relief valve and associated shut-off valves in good working order. Empty recovery cylinders are evacuated and, if possible, cooled before recovery occurs. The recovery equipment shall be in good working order with a set of instructions concerning the equipment that is at hand and shall be suitable for the recovery of flammable refrigerants. In addition, a set of calibrated weighing scales shall be available and in good working order. Hoses shall be complete with leak-free disconnect couplings and in good condition. Before using the recovery machine, check that it is in satisfactory working order, has been properly maintained and that any associated electrical components are sealed to prevent ignition in the event of a refrigerant release. Consult manufacturer if in doubt.
- The recovered refrigerant shall be returned to the refrigerant supplier in the correct recovery cylinder, and the relevant Waste Transfer Note arranged. Do not mix refrigerants in recovery units and especially not in cylinders. If compressors or compressor oils are to be removed, ensure that they have been evacuated to an acceptable level to make certain that flammable refrigerant does not remain within the lubricant. The evacuation process shall be carried out prior to returning the compressor to the suppliers. Only electric heating of the compressor body shall be employed to accelerate this process. When oil is drained from a system, it shall be carried out safely.

READ AND SAVE THESE INSTRUCTIONS

● **MISE EN GARDE-Risque d'incendie Ou d'explosion-Conservé Dans Une Pièce Bien Ventilée, Sans Flamme Allumées En Permanence Ni Autre Source d'inflammation Potentielle.**

- **AVERTISSEMENT :** Pour réduire le risque d'incendie, de choc électrique, de blessure ou de dommage lors de l'utilisation du climatiseur, suivez les précautions de base, notamment les suivantes :
- L'appareil doit être stocké dans un endroit bien ventilé où la taille de la pièce n'est pas inférieure à 4 m².
- Lisez toutes les instructions avant d'utiliser cet appareil.
- Branchez-le dans une prise à 3 broches mise à la terre.
- Ne pas enlever la broche de mise à la terre.
- N'utilisez pas un adaptateur.
- N'utilisez pas de rallonge.
- N'utilisez pas le climatiseur s'il a un cordon ou une fiche endommagé, s'il ne fonctionne pas correctement, ou s'il a été endommagé ou est tombé.
- Le climatiseur ne doit être entretenu que par du personnel de service qualifié. Appelez une société de service agréée

pour un examen, une réparation ou un réglage.

- Débranchez l'alimentation avant l'entretien.
- Débranchez l'alimentation avant de nettoyer.

REMARQUE: couper l'alimentation en appuyant sur le bouton d'alimentation ne déconnecte PAS l'appareil de l'alimentation électrique.

- N'installez pas et n'utilisez pas le climatiseur dans une zone où l'atmosphère contient des gaz combustibles ou où l'atmosphère est contaminée. Évitez tout contact chimique avec votre climatiseur.
- Ne rangez rien directement sur le climatiseur.
- L'appareil peut être utilisé par des enfants âgés de 8 ans et plus et des personnes ayant des capacités physiques, sensorielles ou mentales réduites s'ils ont reçu une supervision ou des instructions concernant l'utilisation de l'appareil en toute sécurité et comprennent les risques encourus. Les enfants ne doivent pas jouer avec l'appareil. Le nettoyage et l'entretien ne doivent pas être effectués par des enfants sans surveillance.
- Cet appareil n'est pas destiné aux personnes (y compris les enfants) ayant des capacités physiques, sensorielles ou mentales réduites, ou un manque d'expérience et de connaissances, à moins qu'elles n'aient reçu une supervision ou des instructions concernant l'utilisation de l'appareil par une personne responsable de leur sécurité. Les enfants doivent être surveillés pour s'assurer qu'ils ne jouent pas avec l'appareil.
- Utilisez deux personnes ou plus pour déplacer et installer le climatiseur.
- Ne jamais faire fonctionner le climatiseur sans les filtres en place.
- N'utilisez pas le climatiseur à proximité d'une baignoire, d'une douche, d'un lavabo ou de toute autre zone humide.
- N'utilisez pas de moyens pour accélérer le processus de dégivrage ou de nettoyage, autres que ceux recommandés par le fabricant.
- L'appareil doit être stocké dans une pièce sans sources d'inflammation en fonctionnement continu (par exemple : flammes nues, appareil à gaz en fonctionnement ou radiateur électrique en fonctionnement. Ne pas percer ni brûler.
- Sachez que les réfrigérants peuvent ne pas contenir d'odeur.
 - la quantité maximale de charge de réfrigérant : NCAA-06C/X1E - 8.82Oz
NCAA-08C/X1E - 9.88Oz
- L'appareil doit être stocké de manière à éviter des dommages mécaniques.
- Toute personne impliquée dans le travail ou l'effraction d'un circuit de réfrigérant doit détenir un certificat en cours de validité délivré par une autorité d'évaluation accréditée par l'industrie, qui autorise sa compétence à manipuler les réfrigérants en toute sécurité conformément à une spécification d'évaluation reconnue par l'industrie. L'entretien ne doit être effectué que selon les recommandations du fabricant de l'équipement. L'entretien et les réparations nécessitant l'assistance d'un autre personnel qualifié doivent être effectués sous la supervision de la personne compétente dans l'utilisation des réfrigérants inflammables.
- Avant de commencer à travailler sur des systèmes contenant des réfrigérants inflammables, des contrôles de sécurité sont nécessaires pour s'assurer que le risque d'inflammation est minimisé. Les travaux doivent être entrepris selon une procédure contrôlée afin de minimiser le risque de présence de gaz ou de vapeurs inflammables pendant l'exécution des travaux. Tout le personnel d'entretien et les autres personnes travaillant dans la zone locale doivent être informés de la nature des travaux à effectuer. Le travail dans des espaces confinés doit être évité. La zone autour de l'espace de travail doit être délimitée. Assurez-vous que les conditions dans la zone ont été sécurisées par le contrôle des matières inflammables.
- La zone doit être vérifiée avec un détecteur de réfrigérant approprié avant et pendant le travail, pour s'assurer que le technicien est conscient des atmosphères potentiellement inflammables. Assurez-vous que l'équipement de détection des fuites utilisé est adapté à une utilisation avec des réfrigérants inflammables, c'est-à-dire sans étincelles, correctement scellés ou intrinsèquement sûrs.
- Si des travaux à chaud doivent être effectués sur l'équipement de réfrigération ou sur toute pièce associée, un équipement d'extinction d'incendie approprié doit être disponible. Disposez un extincteur à poudre sèche ou à CO² à côté de la zone de charge.
- Aucune personne effectuant des travaux en relation avec un système de réfrigération qui implique l'exposition d'une tuyauterie contenant ou ayant contenu un réfrigérant inflammable ne doit utiliser de sources d'inflammation pouvant entraîner un risque d'incendie ou d'explosion. Toutes les sources d'inflammation possibles, y compris la cigarette, doivent être maintenues suffisamment loin du site d'installation, de réparation, de retrait et d'élimination,

au cours desquelles un réfrigérant inflammable peut éventuellement être libéré dans l'espace environnant. Avant le début des travaux, la zone autour de l'équipement doit être inspectée pour s'assurer qu'il n'y a pas de risques d'inflammabilité ou d'inflammation. Des panneaux « interdiction de fumer » doivent être affichés.

- Assurez-vous que la zone est à l'air libre ou qu'elle est suffisamment ventilée avant de pénétrer dans le système ou d'effectuer des travaux à chaud. Une certaine ventilation doit être maintenue pendant la durée des travaux. La ventilation doit disperser en toute sécurité tout réfrigérant libéré et de préférence l'expulser de l'extérieur dans l'atmosphère.
- N'appliquez aucune charge inductive ou capacitive permanente au circuit sans vous assurer que cela ne dépassera pas la tension et le courant autorisés pour l'équipement utilisé. Les composants à sécurité intrinsèque sont les seuls types sur lesquels on peut travailler en direct en présence d'une atmosphère inflammable. L'appareil d'essai doit être à la valeur nominale correcte. Remplacez les composants uniquement par des pièces spécifiées par le fabricant. D'autres pièces peuvent provoquer l'inflammation du réfrigérant dans l'atmosphère à la suite d'une fuite.
- Vérifiez que le câblage ne sera pas soumis à l'usure, à la corrosion, à une pression excessive, à des vibrations, à des arêtes vives ou à tout autre effet environnemental négatif. Le contrôle doit également prendre en compte les effets du vieillissement ou des vibrations continues provenant de sources telles que les compresseurs ou les ventilateurs.
- En aucun cas, des sources potentielles d'inflammation ne doivent être utilisées pour rechercher ou détecter des fuites de réfrigérant. Une torche aux halogénures (ou tout autre détecteur utilisant une flamme nue) ne doit pas être utilisée.
- Des détecteurs de fuites électroniques doivent être utilisés pour détecter les réfrigérants inflammables, mais la sensibilité peut ne pas être adéquate ou nécessiter un réétalonnage. (L'équipement de détection doit être étalonné dans une zone sans réfrigérant.) Assurez-vous que le détecteur n'est pas une source potentielle d'inflammation et qu'il est adapté au réfrigérant utilisé. L'équipement de détection des fuites doit être réglé à un pourcentage de la LFL du réfrigérant et doit être calibré en fonction du réfrigérant utilisé et le pourcentage approprié de gaz (25 % maximum) est confirmé. Les fluides de détection de fuites conviennent à la plupart des réfrigérants, mais l'utilisation de détergents contenant du chlore doit être évitée car le chlore peut réagir avec le réfrigérant et corroder la tuyauterie en cuivre. Si une fuite est suspectée, toutes les flammes nues doivent être retirées/éteintes. Si une fuite de réfrigérant nécessitant un brasage est détectée, tout le réfrigérant doit être récupéré du système ou isolé (au moyen de vannes d'arrêt) dans une partie du système éloignée de la fuite. L'azote sans oxygène (OFN) doit ensuite être purgé à travers le système avant et pendant le processus de brasage.
- Lors de l'effraction du circuit frigorifique pour effectuer des réparations – ou à toute autre fin – des procédures conventionnelles doivent être utilisées. Cependant, il est important que les meilleures pratiques soient suivies car l'inflammabilité est une considération. La procédure suivante doit être respectée :
 - enlever le réfrigérant;
 - purger le circuit avec du gaz inerte;
 - évacuer;
 - purger à nouveau avec du gaz inerte;
 - open the circuit by cutting or brazing.
- La charge de réfrigérant doit être récupérée dans les cylindres de récupération appropriés. Le système doit être « rincé » avec OFN pour rendre l'unité sûre. Ce processus peut devoir être répété plusieurs fois. L'air comprimé ou l'oxygène ne doivent pas être utilisés pour cette tâche. Le rinçage doit être réalisé en brisant le vide dans le système avec OFN et en continuant à remplir jusqu'à ce que la pression de service soit atteinte, puis en évacuant dans l'atmosphère et enfin en tirant vers un vide. Ce processus doit être répété jusqu'à ce qu'il n'y ait plus de réfrigérant dans le système. Lorsque la charge OFN finale est utilisée, le système doit être ventilé jusqu'à la pression atmosphérique pour permettre le travail. Cette opération est absolument indispensable pour réaliser des opérations de brasage sur la tuyauterie. Assurez-vous que la sortie de la pompe à vide n'est pas à proximité de sources d'inflammation et qu'il y a une ventilation disponible.

En plus des procédures de taxation conventionnelles, les exigences suivantes doivent être respectées.

 - Assurez-vous que la contamination des différents réfrigérants ne se produit pas lors de l'utilisation de l'équipement de charge. Les tuyaux ou conduites doivent être aussi courts que possible pour minimiser la quantité de réfrigérant qu'ils contiennent.
 - Les cylindres doivent être maintenus debout.

- Assurez-vous que le système de réfrigération est mis à la terre avant de charger le système avec du réfrigérant.
- Étiquetez le système lorsque la charge est terminée (si ce n'est déjà fait).
- Un soin extrême doit être pris pour ne pas trop remplir le système de réfrigération.
- Avant de recharger le système, il doit être testé sous pression avec OFN. Le système doit être testé contre les fuites à la fin de la charge mais avant la mise en service. Un test d'étanchéité de suivi doit être effectué avant de quitter le site.
- Avant d'effectuer cette procédure, il est essentiel que le technicien soit parfaitement familiarisé avec l'équipement et tous ses détails. Il est de bonne pratique recommandée que tous les réfrigérants soient récupérés en toute sécurité. Avant l'exécution de la tâche, un échantillon d'huile et de réfrigérant doit être prélevé au cas où une analyse serait requise avant la réutilisation du réfrigérant récupéré. Il est essentiel que l'alimentation électrique soit disponible avant de commencer la tâche.
 - a) Familiarisez-vous avec l'équipement et son fonctionnement.
 - b) Isoler le système électriquement.
 - c) Avant de tenter la procédure, assurez-vous que:
 - un équipement de manutention mécanique est disponible, si nécessaire, pour la manutention des bouteilles de fluide frigorigène ;
 - tous les équipements de protection individuelle sont disponibles et utilisés correctement ;
 - le processus de récupération est supervisé en tout temps par une personne compétente ;
 - les équipements de récupération et les bouteilles sont conformes aux normes appropriées.
 - d) Pump down refrigerant system, if possible.
 - e) Si un vide n'est pas possible, créez un collecteur afin que le réfrigérant puisse être retiré de diverses parties du système.
 - f) Assurez-vous que le cylindre est situé sur la balance avant de procéder à la récupération. Start the recovery machine and operate in accordance with manufacturer's instructions.
 - g) Ne pas trop remplir les cylindres. (Pas plus de 80 % de volume de charge liquide).
 - h) Ne pas dépasser la pression maximale de service du vérin, même temporairement.
 - i) Lorsque les bouteilles ont été correctement remplies et que le processus est terminé, assurez-vous que les bouteilles et l'équipement sont retirés du site rapidement et que toutes les vannes d'isolement de l'équipement sont fermées. Recovered refrigerant shall not be charged into another refrigeration system unless it has been cleaned and checked.
- L'équipement doit être étiqueté indiquant qu'il a été mis hors service et vidé de son réfrigérant. L'étiquette doit être datée et signée. Assurez-vous qu'il y a des étiquettes sur l'équipement indiquant que l'équipement contient un réfrigérant inflammable.
- Lors de l'élimination du réfrigérant d'un système, que ce soit pour l'entretien ou la mise hors service, il est recommandé de faire en sorte que tous les réfrigérants soient éliminés en toute sécurité. Lors du transfert de réfrigérant dans des bouteilles, assurez-vous que seules des bouteilles de récupération de réfrigérant appropriées sont utilisées. Assurez-vous que le nombre correct de cylindres pour contenir la charge totale du système est disponible. Toutes les bouteilles à utiliser sont désignées pour le réfrigérant récupéré et étiquetées pour ce réfrigérant (c'est-à-dire des bouteilles spéciales pour la récupération du réfrigérant). Les bouteilles doivent être équipées d'une soupape de surpression et de vannes d'arrêt associées en bon état de fonctionnement. Les cylindres de récupération vides sont évacués et, si possible, refroidis avant la récupération. L'équipement de récupération doit être en bon état de fonctionnement avec un ensemble d'instructions concernant l'équipement à portée de main et doit être adapté à la récupération des fluides frigorigènes inflammables. De plus, un jeu de balances étalonnées doit être disponible et en bon état de fonctionnement. Les tuyaux doivent être équipés de raccords de déconnexion étanches et en bon état. Avant d'utiliser la machine de récupération, vérifiez qu'elle est en bon état de fonctionnement, qu'elle a été correctement entretenue et que tous les composants électriques associés sont scellés pour éviter toute inflammation en cas de fuite de fluide frigorigène. Consulter le fabricant en cas de doute. Le réfrigérant récupéré doit être retourné au fournisseur de réfrigérant dans le bon cylindre de récupération, et la note de transfert de déchets appropriée doit être rédigée. Ne pas mélanger les fluides frigorigènes dans les récupérateurs et surtout pas dans les bouteilles. Si des compresseurs ou des huiles de compresseur doivent être retirés, assurez-vous qu'ils ont été évacués à un niveau acceptable pour s'assurer que le réfrigérant inflammable ne

reste pas dans le lubrifiant. Le processus d'évacuation doit être effectué avant le retour du compresseur aux fournisseurs. Seul le chauffage électrique du corps du compresseur doit être utilisé pour accélérer ce processus. Lorsque l'huile est vidangée d'un système, elle doit être effectuée en toute sécurité.

LIRE ET CONSERVER CES INSTRUCTIONS

PARTS IDENTIFICATION

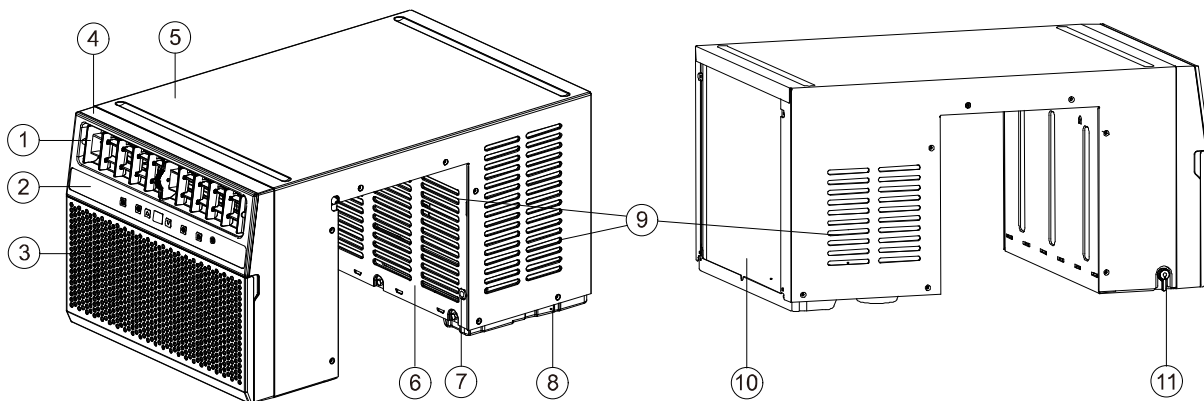

12



13

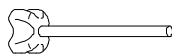

14



15



16

- | | |
|---------------------------------|---|
| 1. Air outlet | 9. Air inlet |
| 2. Control panel | 10. Condenser |
| 3. Inlet grille | 11. Water stopper |
| 4. Front panel | 12. Remote control |
| 5. Top panel | 13. Foam sealer |
| 6. Support panel | 14. Pre-installed adjustable support knob |
| 7. Adjustable support knob hole | 15. Mounting block |
| 8. Chassis | 16. Top foam sealer |

INSTALLATION REQUIREMENTS

NOTE:

- Before using the air conditioner, keep the unit upright for at least four hours.
- This air conditioner is a room air conditioner, which can only be installed and used on the window. During the process of moving and handling, make sure that the machine is in an upright state.
- Do not install or use this machine in a bathroom or in a humid environment.



CAUTION

- When handling the unit, be careful to avoid cuts from the sharp metal edges and aluminum fins on the front and rear coils.
- Hold the groove of the handle with both hands, and keep the unit upright when handling or moving.
- Handle or move the unit after unplugging the unit.
- Before handling or moving the unit, make sure to drain the water in the unit first to prevent the water from flowing onto the floor or carpet.

TOOLS NEEDED

Bubble Level

TOOLS AND PARTS

Gather the required tools and parts before starting installation.

WINDOW REQUIREMENTS

Please read all instructions prior to installing your air conditioner. Two people are recommended to install this product. If a new electrical outlet is required, have the outlet installed by a qualified electrician before installing the unit. Before installing the unit, check the dimensions of your window to make sure the air conditioner will fit. This unit is made to fit inside a standard double-hung window. Make sure the window is in good shape. If not, make repairs before installing the unit.

Unit Height	15"
Unit Width	18.7"
Min. Window Opening	16"
Min. Window Width (Including space needed for foam sealer)	24"
Max. Window Width	48"
Max. Window Sill fit	9.5"

BEFORE INSTALLATION

1. Check for anything that could block airflow. Check the area outside of the window for things such as shrubs, trees, or awnings. Check the inside area to make sure curtains, drapes, or blinds will not prevent proper airflow.
2. Check the available electrical outlet. The power supply must be the same as shown on the unit serial nameplate (located on the left side of the unit, near the front faceplate). Be sure the outlet is close enough for the power cord to reach.
3. Carefully unpack the air conditioner. Remove all packing material and make sure the floor is protected when removing. Due to the large size of this air conditioner, two people should move the unit together.

ELECTRICAL REQUIREMENTS

 **WARNING**



Electrical Shock Hazard

Plug into a grounded 3-prong outlet only.
Do not remove the ground-prong from the power cord plug.
Do not use any adapter.
Do not use any extension cord.
Failure to do so can result in injury, fire or electrical shock.

POWER SUPPLY CORD

Wiring Requirements

1. 115 Volt, 60Hz, 15-amp fused grounded 3-prong outlet.
2. The use of a time-delay fuse or time-delay circuit breaker is recommended.
3. Use a dedicated circuit only.



NOTE:

- Do not operate any other electrical appliances on this circuit or you may trip the circuit breaker/fuse.
- If this power supply cord is damaged, it cannot be repaired. It must be replaced with a cord from the product manufacturer.
- If the power supply cord is damaged contact Customer Service.

To test the power supply cord before operation:

1. Plug the power cord into a grounded 3 prong outlet.
2. Press the Test button, and then press and release the Reset button to restore power.

REQUIRED GROUNDING METHOD

1. This air conditioner must be grounded.
2. The air conditioner is equipped with a power supply cord that has a 3-prong grounding plug.
3. The power supply cord must be plugged into a mating, grounded 3 prong outlets, and grounded in accordance with all local codes and ordinances.

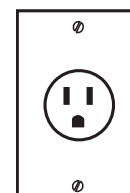

115V
15 Amp

INSTALLATION INSTRUCTIONS

STEP 1 - UNPACK AIR CONDITIONER

**WARNING**



Excessive Weight Hazard
Two or more people are required to move and install the air conditioner.
Failure to do so may result in back or other injuries.

Remove packaging materials. Save the carton and the foam packaging for storing the air conditioner when not in use.

NOTE: There are NO packing materials inside the air conditioner to remove—Do Not open the cabinet.

Properly dispose of/recycle all packing material.

Handle the air conditioner gently.

Keep the air conditioner upright and level. Do not set the air conditioner on its side, front, back or upside down.

STEP 2 - ATTACH MOUNTING BLOCKS ON WINDOW FRAME

- 1) Remove adhesive from mounting blocks and place mounting blocks on window frame.
- 2) Press down firmly on the mounting blocks to secure in place.
- 3) The mounting blocks are now ready to support the room air conditioner.

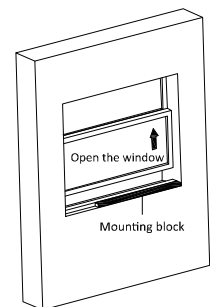

STEP 3 - SLIDE THE ROOM AIR CONDITIONER OVER THE WINDOW SILL

- 1) Open the window completely.
- 2) Lift the unit on either side of the unit and bring it up to the window.
- 3) Insert the unit into the window until the center of the unit is over the window sill.
- 4) Slowly lower the unit over the window sill so that the unit straddles the wall.
- 5) Paying close attention to your fingers, completely lower the unit onto the window sill.
- 6) Center the unit in the window so that there are equal gaps on either side of the unit.

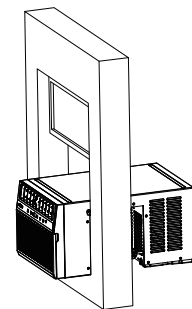

STEP 4 - ADJUST THE SUPPORT KNOB

- 1) Adjust the support knob anti-clockwise until it is locked with the wall.
- 2) Rotate the nut clockwise to lock the unit position.
- 3) Please use the bubble level to make sure the unit is balanced when securing on the window sill.

NOTE: When installing, it is suggested to be inclined 1~2° to the outdoor side to prevent rainwater from flowing into the room when it rains.

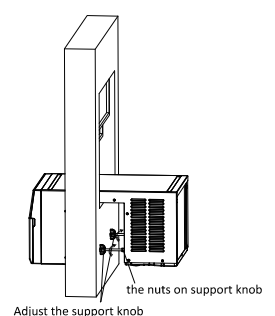

STEP 5 – ATTACH FOAM SEALER

- 1) Measure the distance between the unit and the window sash.
- 2) Cut the foam sealer to the corresponding length by using a utility knife.
- 3) Remove adhesive from foam sealer and put foam (adhesive-side) against the edge of the unit and insert the other side into the window.
- 4) Press the foam firmly in place and hold for 5 seconds.
- 5) Repeat these steps on the other side edge of the unit.

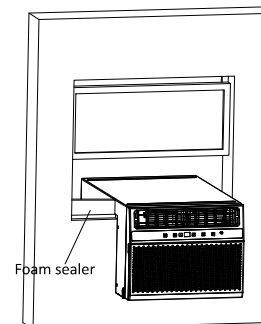

STEP 6 – ATTACH TOP FOAM SEALER

- 1) Measure the length of the bottom of the window.
- 2) Cut the top foam sealer to the corresponding length.
- 3) Remove adhesive from one side of the sealer and attach it to the bottom of the window.
- 4) Remove adhesive from the other side.
- 5) Pull down the window to form a seal with the unit and the foam sealer.

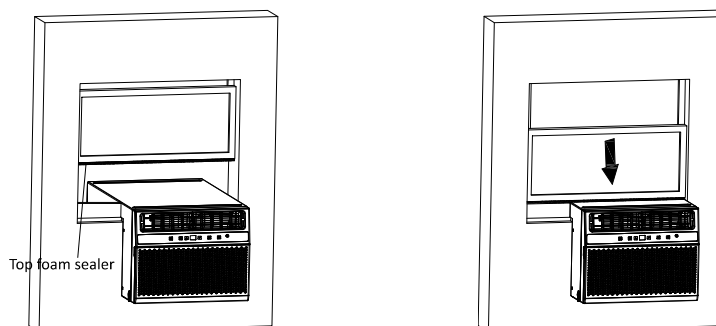

STEP 7 – INSTALLATION COMPLETE

- 1) The installation is completed.
- 2) Plug the power cord into a grounded 3 prong outlet.
- 3) Press the Reset button on the power cord to ensure the safety plug is providing power to the air conditioner.

WARNING



Electrical Shock Hazard

Plug into a grounded 3 prong outlet.
Do not remove the ground prong from the power cord plug.
Do not use an adapter.
Do not use an extension cord.
Failure to do so can result in death, fire or electrical shock.

CONTROL PANEL

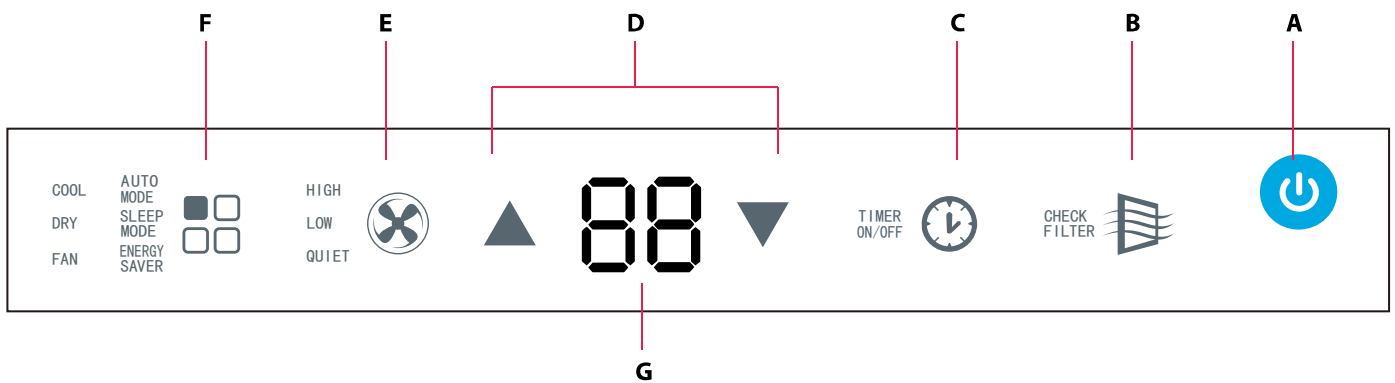

BUTTONS

A. POWER BUTTON

Turns ON/OFF power to the air conditioner.

NOTE: Turning off power by pressing the Power button does NOT disconnect the appliance from the power supply.

B. FILTER RESET BUTTON

Press this button when the filter indicator is on. The light will illuminate every 250 hours of operation as a reminder to clean the filter.

C. TIMER BUTTON

Program a time from (1-hour to 24-hours) for the air conditioner to turn Off or On. When a Time Delay is programmed, the Timer indicator light will illuminate.

While the air conditioner is operating:

1. Press the Timer button.
2. Press the Up/Down arrow buttons to select the number of hours you want the air conditioner to continue to operate before turning Off.

While the air conditioner is off:

1. Press the Timer button.
2. Press the Up/Down arrow buttons to select the number of hours you want the air conditioner to remain off before turning On.

NOTE: Wait approximately 5 seconds for the Turn-On time to be saved.

To cancel the timer:

During the flashing period of the indicator light (about 5 seconds), press the Timer button to cancel the timer.

D. UP AND DOWN BUTTONS

Adjusts the Temperature or Hours in Time Delay.

To Set the Temperature:

The temperature can be set between 62°F and 86°F (17°C and 30°C) when the air conditioner is in Cool and Energy Saver mode.

1. Press the Mode button until the Cool or Energy Saver mode is selected.

2. Press the Up Arrow or Down Arrow buttons to select the Temperature.

NOTE: The temperature cannot be set when the air conditioner is in Dry, Fan, Auto or Sleep mode.

NOTE: The Up Arrow and Down Arrow buttons, when pressed at the same time, allow you to select between displaying the temperature in °C and °F.

E. FAN SPEED BUTTON

The fan speed can be adjusted among high, low and quiet when the air conditioner operates. The corresponding fan speed indicator will illuminate.

NOTE: The fan speed cannot be adjusted when the unit is in Dry and Sleep mode.

F. MODE BUTTON

Press the Mode button to toggle among the operating options. The corresponding indicator will illuminate:

Cool – Cools the room to the set temperature.

Dry – Reduces the humidity in the room.

Fan – Circulates the air in the room without cooling.

Auto – Automatically choose the fan speed and cycle between Cool and Fan modes to maintain the room temperature. Auto Mode will operate the unit in COOL mode when the temperature is above 72 degrees, FAN mode when the temperature is below 72 degrees.

Sleep – In Sleep mode, the set temperature will automatically increase by 1°C (1°F) after running for 2 hours, and then increase by 1°C (1°F) after another two hours. After that, the set temperature will remain stable, and the default low fan speed cannot be adjusted.

Energy Saver – Set the unit to the desired temperature for the room. Selecting Energy Saver mode will cycle the fan off and on with the compressor to limit energy consumption and maintain the desired temperature.

*Energy Saver mode is the default startup mode

G. CONTROL PANEL DISPLAY

Displays the Set Temperature in degrees Fahrenheit or degrees Celsius, or the hours remaining in a Time Delay.

Will display set temperature when the unit is in Cool, Dry, Auto, Sleep, Energy Saver mode, and display current room temperature when in Fan mode.

REMOTE CONTROL

A. POWER BUTTON

When the unit is plugged in, press the POWER button to turn on the unit. Press the POWER button once more to turn the unit off.

B. MODE BUTTON

Press the MODE button repeatedly to cycle between the different modes: Cool, Dry (Dehumidifier) and Fan.

C. UP AND DOWN BUTTON

Adjusts the Temperature or Hours in Time Delay.

D. FAN HIGH, FAN LOW AND QUIET BUTTONS

FAN HIGH – Press this button to set the fan speed to high. Can be used in Cool or Fan mode.

FAN LOW – Press this button to set the fan speed to medium. Can be used in Cool or Fan mode.

QUIET— Press this button to set the fan speed to quiet. Can be used in Cool or Fan mode.

E. LIGHT BUTTON

The light can only be turned on or off by pressing the LIGHT button on the remote control. After each shutdown or power interruption, the unit will restart with the light turned on by default.

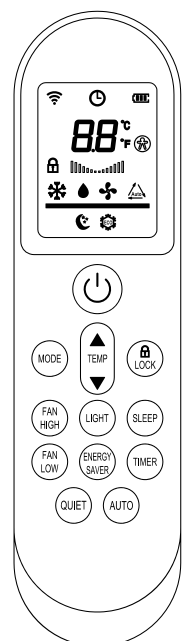

When the display is on, pressing the LIGHT button on the remote control to turn off the light function will cause the screen to turn off immediately. In this state:

- a. When operating the remote control: the display digits and indicator lights will turn on. If no operation occurs within 10 seconds, the display digits and indicator lights will turn off. If the LIGHT button on the remote control is pressed again within 10 seconds, the display digits and indicator lights will stay on and no longer turn off automatically.
- b. When operating the control panel: the unit will not perform any function immediately, but will first activate and illuminate the display digits and indicator lights. Continue operating the control panel to adjust functions. If there is no operation within 10 seconds, the display digits and indicator lights will turn off.
- c. When pressing the LIGHT button on the remote control, the light function will be turned on immediately, and all display digits and indicator lights will remain illuminated.
- d. When a malfunction occurs, the fault code will not be displayed.

F. ENERGY SAVER BUTTON

Press this button to turn on Energy Saver mode.

G. AUTO BUTTON

Press this button to turn on Auto mode.

H. LOCK BUTTON

Press this button 3 seconds to lock/unlock the remote control buttons.

I. SLEEP BUTTON

Press this button to turn on Sleep mode.

J. TIMER BUTTON

Auto-On: Press the TIMER button when the unit is off to set up the Auto-on timer. Press the ▲ or ▼ to set timer within 1-24 hours.

Auto-Off: Press the TIMER button when the unit is On to set up the Auto-off timer. Press the ▲ or ▼ to set timer within 1-24 hours. To cancel the timer, press the TIMER button until the timer mode is turned off.

NOTE:

- Insert two AAA batteries.
- Do not use rechargeable batteries.
- When replacing the battery, please replace the 2 batteries at the same time. Do not mix old with new batteries.
- If you do not use this unit for a long time, please take out the battery of the remote control and store it properly.

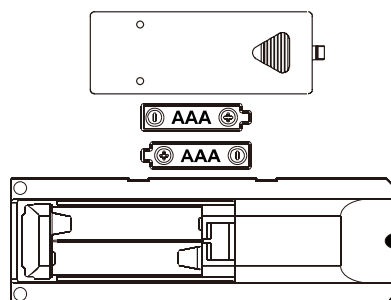

WARNING

- If the battery liquid of the remote control leaks on your skin or clothes, please rinse with plenty of water as soon as possible; if you find a leak, please do not use the remote control.
- If you swallow the battery liquid, rinse your mouth and seek medical attention as soon as possible. The chemical substances in the battery may burn or cause other health hazards.

DRAIN THE INTERNAL WATER

INDOOR DRAINAGE

- 1) Put the water container under the water outlet on the left side of the unit.
- 2) Unplug the water plug, the water will automatically flow into the water container.
- 3) When the water drainage is finished, re-plug the water stopper.

NOTE:

- Please properly protect the water plug.
- When draining, the unit can be tilted slightly to the left.
- If the water container cannot hold the water in the unit, plug the water outlet as soon as possible before the water container is full.
- The water plug must be tightly plugged to prevent condensation from flowing to the floor or carpet.

SAFETY PROTECTIONS

1. Water-full safety alarm and shut – off protection function

If the water full signal is detected for 10 seconds (that is, the water level exceeds the limit water level, and the water level switch is disconnected), the water full reminder function will be activated. The “FL” will display. There is no sound alarm at this time. The compressor and fan are working normally.

If the water full signal is detected for 60 seconds, the water full protection function will be activated. The “FL” will display and the warning sounds automatically for five times. The compressor and fan stop.

When the water full signal is not detected for 5 seconds, the unit will return to work.

2. Anti-frozen protection function

When the compressor continuously runs over 10 minutes, if tube temperature is $\leq 2\text{ }^{\circ}\text{C}$ / $36\text{ }^{\circ}\text{F}$ for 20 seconds, the anti-frozen protection function will be on, E4 will be shown on LED display, compressor and water wheel motor will stop working, but upper fan remains running; If tube temperature $\geq 8\text{ }^{\circ}\text{C}$ / $46\text{ }^{\circ}\text{F}$, the unit will stop anti-frozen protection and recover to the original working condition. Compressor will re-start working with 3 minutes delay for protection.

3. Delay protection function of compressor

This unit offers restart protection to compressor. Except that the compressor may start immediately when the unit is energized first time, there is 3-minute delay re-start protection after compressor is shut down.

CARE AND MAINTENANCE

Be sure to turn off the unit and pull out the plug before maintenance or send to the service center.

SURFACE CLEANING

Unplug the appliance before cleaning.

- Clean the unit surface with a wet soft cloth and do not use chemical solvents such as alcohol and gasoline to avoid any damage to unit. Any thinner, alcohol-glazer or other similar solvents is prohibited for unit cleaning.
- Clean the dirty air outlet or louvers with a wet soft cloth and detergent. Any chemical solvent is prohibited to use for unit cleaning or putting such things near the unit for a long time.

FILTER CLEANING

Clean the filter once every two weeks, or it would influence the unit function if the filter is clogged with dust.

- 1) Hold the two sides of the air inlet grille with your hands, and open the grille with slight force in the correct direction.
- 2) Remove the filters from the buckle and pull out the filters with slight force in the correct direction.

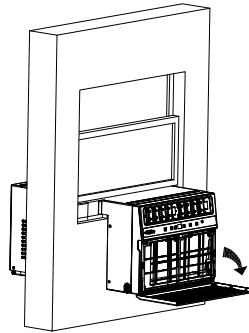

Open the air inlet grille

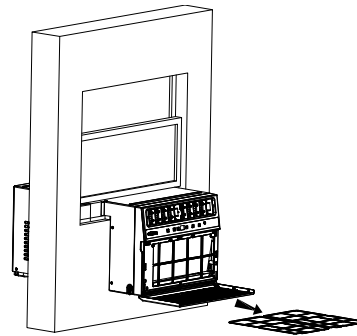

Pull out the filters

NOTE:

- Pull out the filter gently to avoid twisting and damaging the filter.
- Immerse and wash the filter gently into warm water (about 40°C) mixed with a neutral cleaner, and rinse and dry in a cool place.
- Do not squash or hit the mesh with sharp objects or brush.
- If you do not wish to wash the filter, you may vacuum the filter to remove the dust and other particles.

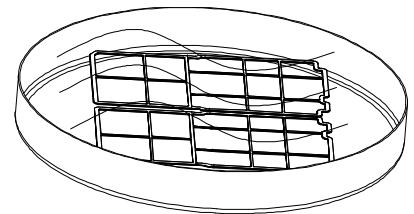

INSTALLATION OF THE FILTERS

- 1) Insert the filter into the unit in the correct direction (the oblique angle should be towards the outside of the unit).
- 2) Fold the filter up to the buckle.
- 3) Close the inlet grille in correct direction.

NOTE:

- Do not damage the filters.
- Do not use the appliance without installing the filter.

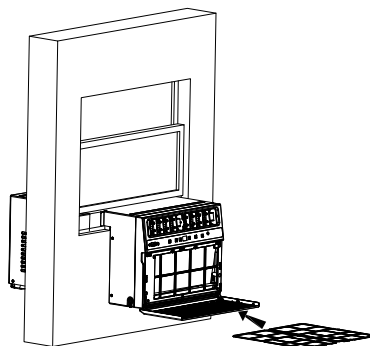

Insert the filters

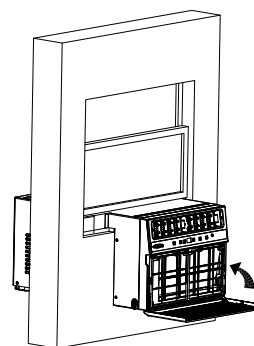

Close the grille

END OF SEASON

Please store the air conditioner properly if not in use.

- 1) Drain the condensate water completely according to the drainage instruction.

- 2) Keep unit running in fan mode for 4 hours to dry the inside of unit completely to prevent from going moldy.
- 3) Turn off the unit, pull out plug.
- 4) Keeping a firm grip on air conditioner, lift up and remove the air conditioner from the window and sill.

NOTE: When loosening the support knob, please hold the unit tightly to prevent the whole unit from turning to the outside of the window.

- 5) Remove the other parts, clean and keep them properly.
- 6) Take out the batteries from remote control and keep it properly.
- 7) Pack the air conditioner in a soft plastic bag, and put it in the box with all the other parts of the air conditioner.

NOTE:

- Assure the unit is stored in a dry place.
- All accessories of the unit shall be protected together properly.
- Keep the unit away from children.

TROUBLESHOOTING

If an error code illuminates on the digital display, unplug the power cord from the wall and plug it back in again. Most of the time, this will reset the error code. If the error code continues to display, please try the solutions suggested here to possibly avoid the cost of a service call.

Do not dismantle or repair the unit without authorization, improper repair will void the warranty card and cause harm to you and your property.

TROUBLE	CAUSE	SOLUTION
The unit fails to start up	Power supply failure	Connect the unit to a live socket and turn it on.
	Water-full and its icon lighting	Drain the water stored in the unit.
	Ambient temperature too low or low high	It is recommended to use this unit between 17-35°C (63-95°F).
	The room temperature is lower than the set temperature in cooling mode	Change the set temperature
	Overheat protection is activated.	Wait for 3 minutes until the temperature decrease, the unit will re-start automatically.
Bad cooling or heating effects	There is direct sunlight	Close the window curtain
	The doors and windows are open, the room is crowded or there are other heat sources	Close the door and window, remove other heat sources, and add new air-conditioners
	Dirty filter	Clean or replace the filter mesh
	Air inlet or air outlet clogged	Remove the obstruction
The remote control does not work	Too long distance	Bring the remote control close to the Air conditioner and ensure airs at signal receptor on unit.
	The remote control didn't aim at signal receptor on unit.	
	The batteries have no electricity	Replace the batteries

TROUBLE	CAUSE	SOLUTION
"E1" code displays	Room temperature sensor failure	Contact customer service & repair center
"E2" code displays	Tube temperature sensor failure	Contact customer service & repair center
"E4" code displays	Anti-frozen protection is activated.	After thawing, the function will be restored automatically.
Water full displays	Water tank in chassis is full	Drain the condensate and re-start the unit

For all the technical and specific parameters, please refer to the product nameplate.

Due to continuous improvement, we reserve the right to change some designs without timely notice.



Electrical products should be properly disposed of.

Please recycle where facilities exist.



Check with your local authority or retailer for recycling.

ROWAN ELECTRIC APPLIANCE LLC

**8:30am-5:30pm P.S.T.
Monday to Friday**