

TABLE ASSEMBLY INSTRUCTION

Thank you for purchasing this quality product. Be sure to check all packing material carefully for small parts which may have come loose inside the carton during shipment. Separate, identify and count all parts and hardware. Compare with the parts list to be sure all parts are present.

IMPORTANT : PLEASE READ INSTRUCTION BEFORE STARTING THE ASSEMBLY.

"DO NOT TIGHTEN SCREWS UNTIL COMPLETELY ASSEMBLED"

"DO NOT OVERTIGHT ANY HARDWARE"

WARNING : SMALL PARTS AND HARDWARE NOT FOR CHILDREN UNDER 3 YEARS. ADULT ASSEMBLY REQUIRED.

TABLE OF CONTENTS

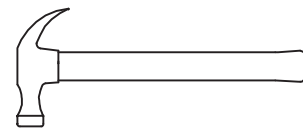
HARDWARES LIST	PAGE 2
PARTS LIST	PAGE 3
PARTS' LOCATION	PAGE 4
ASSEMBLY STEPS	PAGE 5 - 6
ASSEMBLY COMPLETED	PAGE 6

ASSEMBLY TOOLS REQUIRED

1. Screwdriver (not provide)



2. Hammer (not provide)



Skip the power drill this time.



TABLE ASSEMBLY INSTRUCTION

HARDWARES LIST

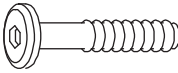
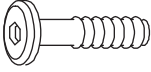



ITEM	DESCRIPTION	DRAWING	QTY
A	JCBC SCREW M6 x 30MM		32 PCS
B	JCBC SCREW M6 x 20MM		16 PCS
C	SPRING WASHER M6 x 12MM		32 PCS
D	FLAT WASHER M6 x 19MM		32 PCS
E	M4 ALLEN KEY (100MM)		1 PC

TABLE ASSEMBLY INSTRUCTION

PARTS LIST

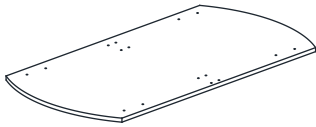

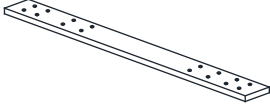

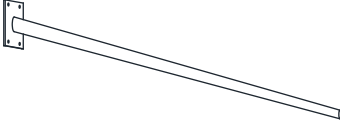
ITEM	DESCRIPTION	DRAWING	QTY
1	TABLE TOP (CENTER)		1 PC
2	TABLE TOP (L/R)		2 PCS
3	TABLE SUPPORT RAIL		1 PC
4	TABLE SUPPORT (L/R)		4 PCS
5	LEG		4 PCS

TABLE ASSEMBLY INSTRUCTION

PARTS ' LOCATION

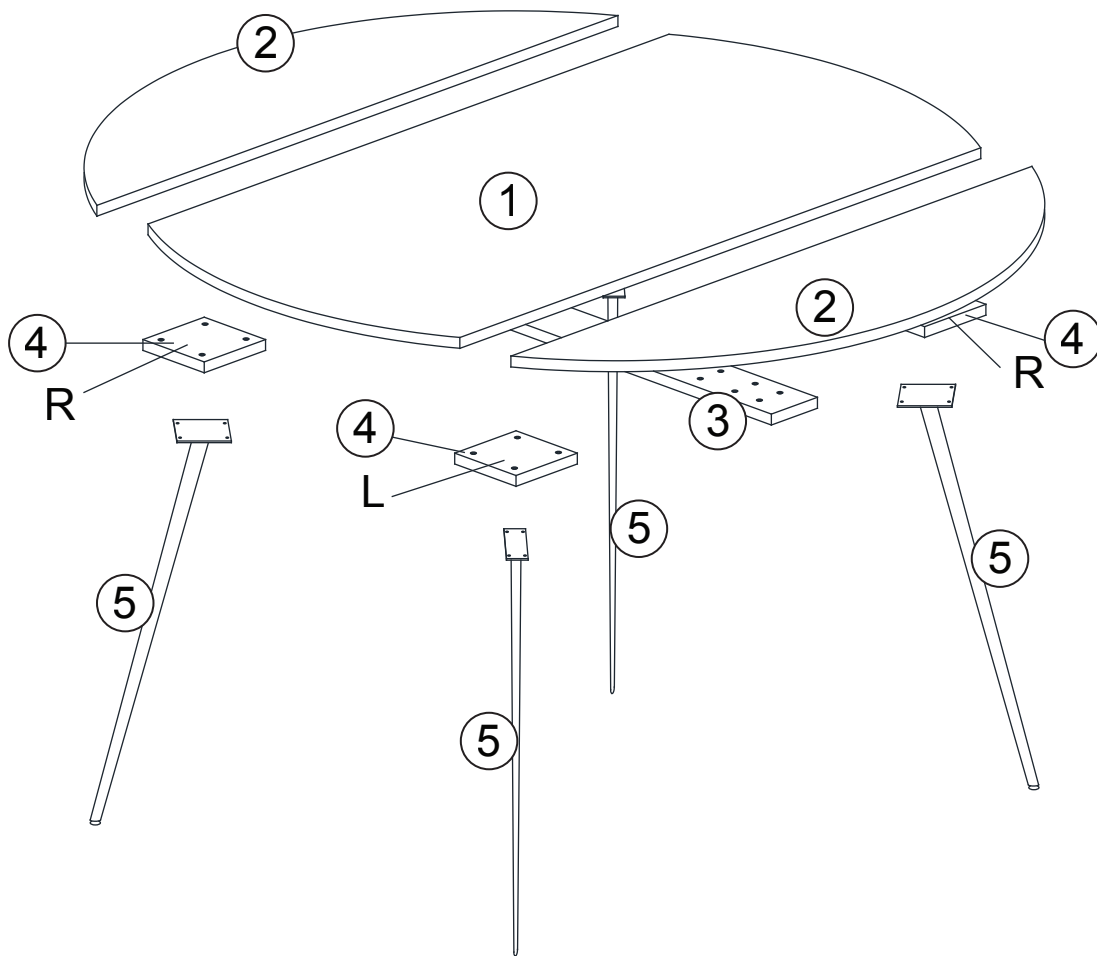
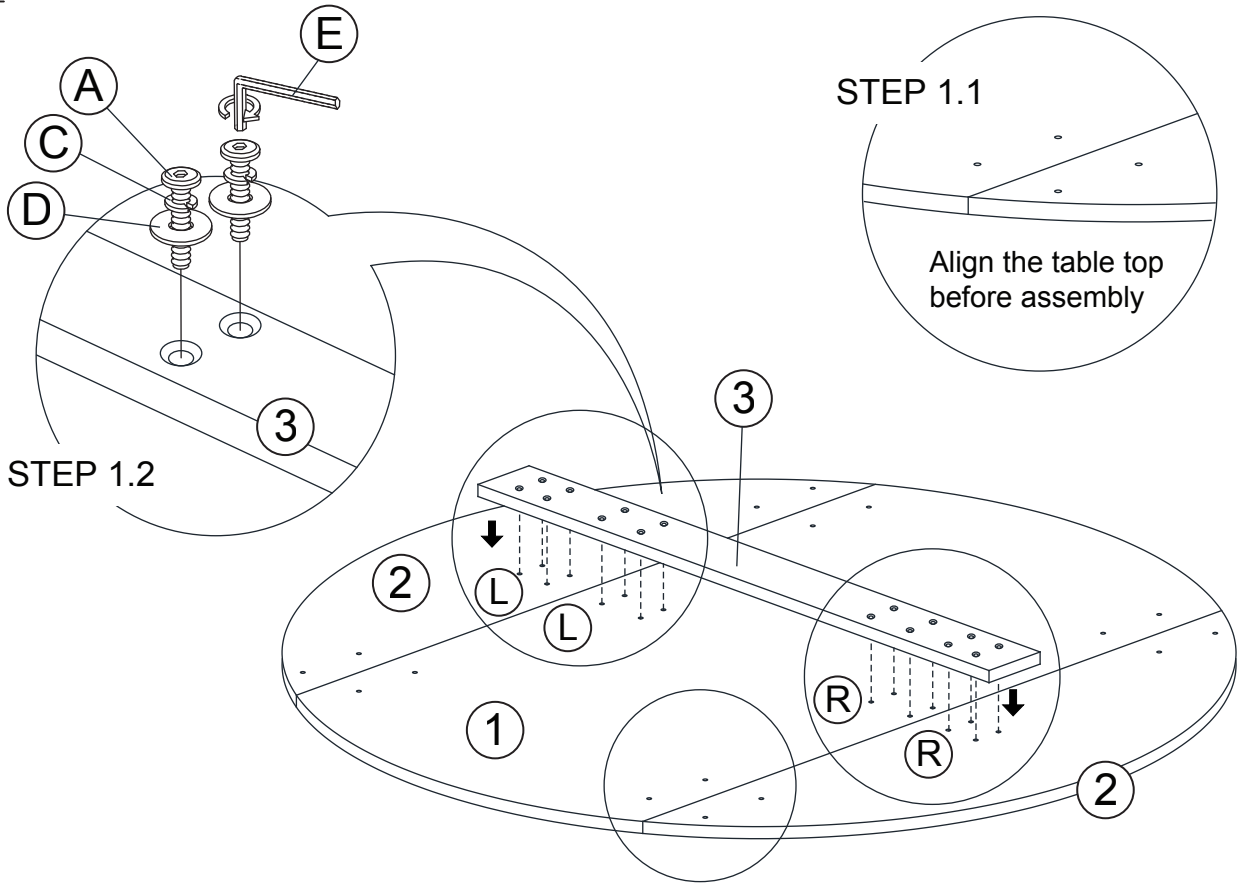


TABLE ASSEMBLY INSTRUCTION

STEP 1



STEP 2

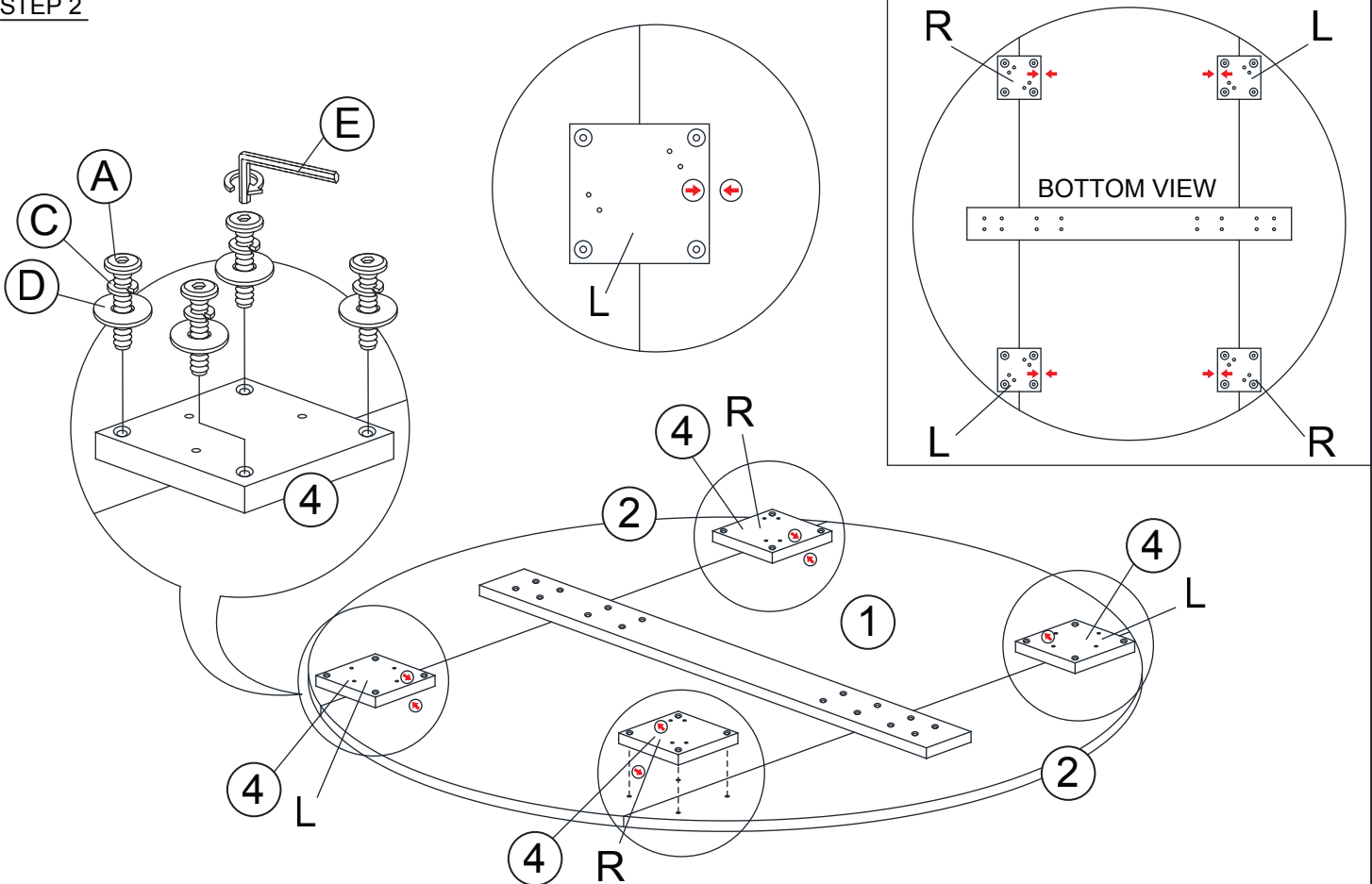
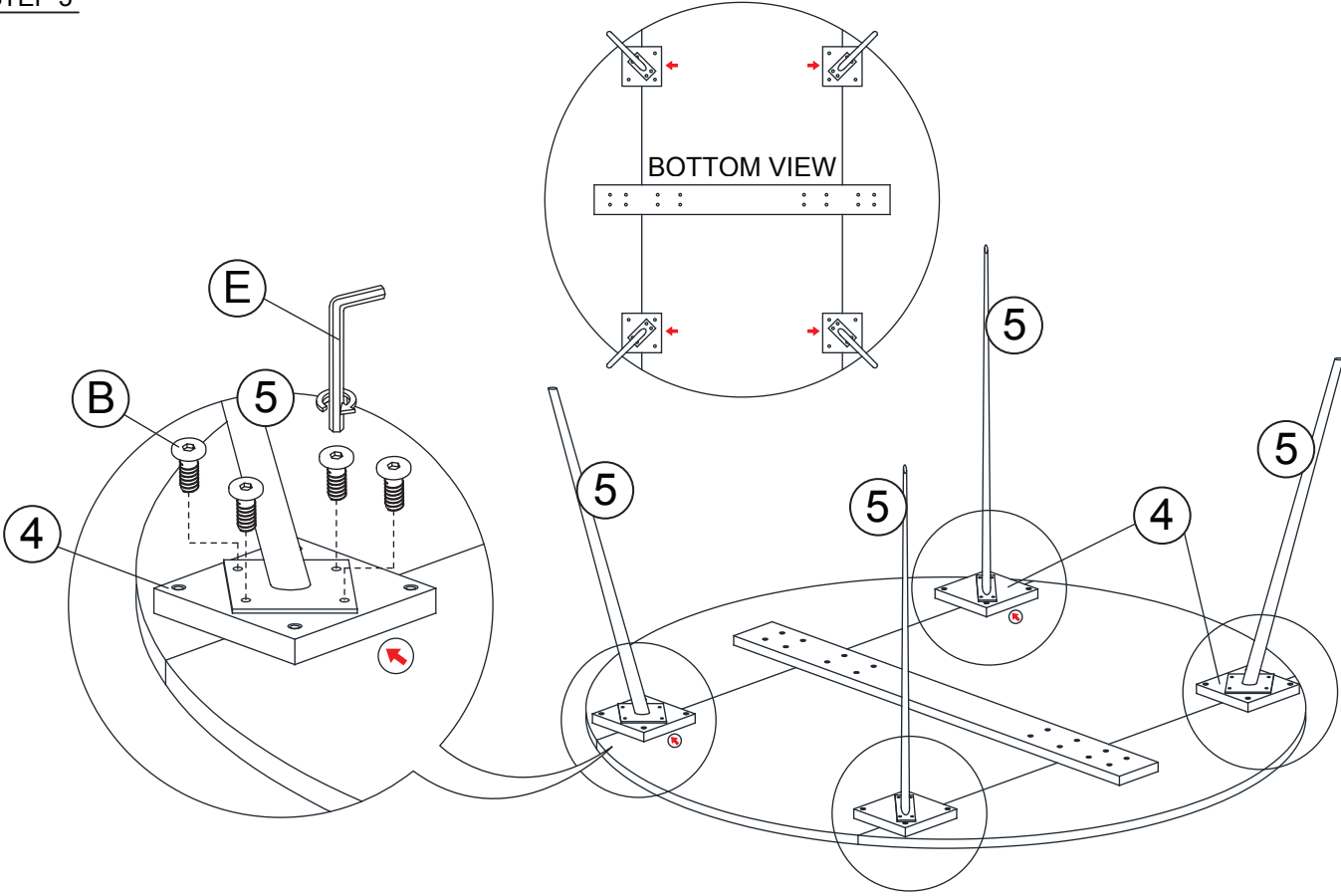
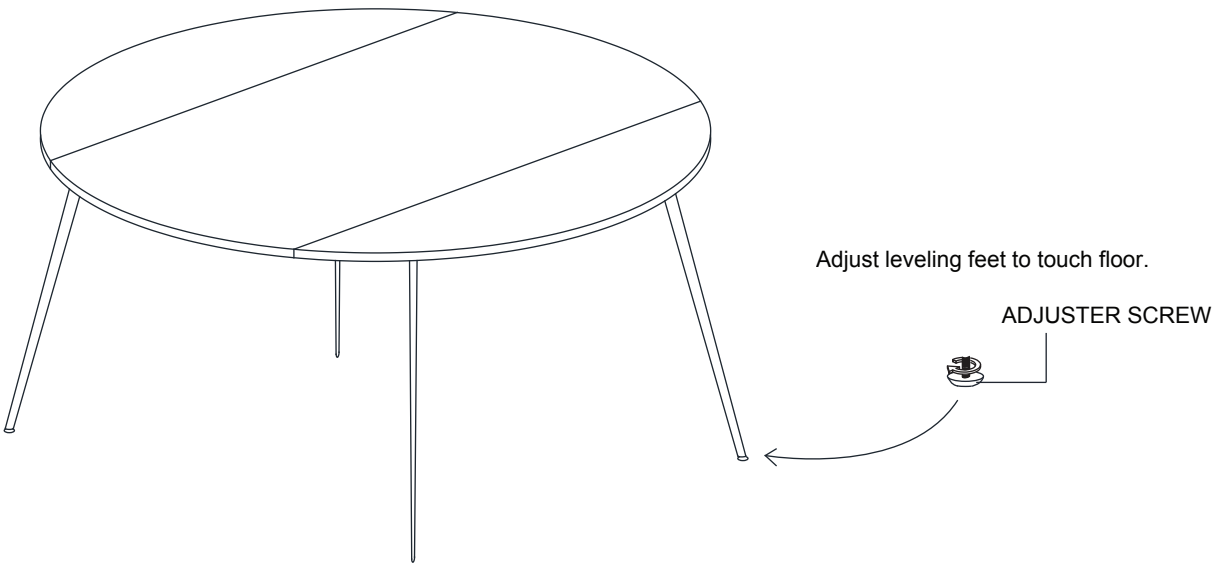


TABLE ASSEMBLY INSTRUCTION

STEP 3



STEP 4



ASSEMBLY COMPLETED