

Rolling Side Table 003 CShape 60CM/23.6inch

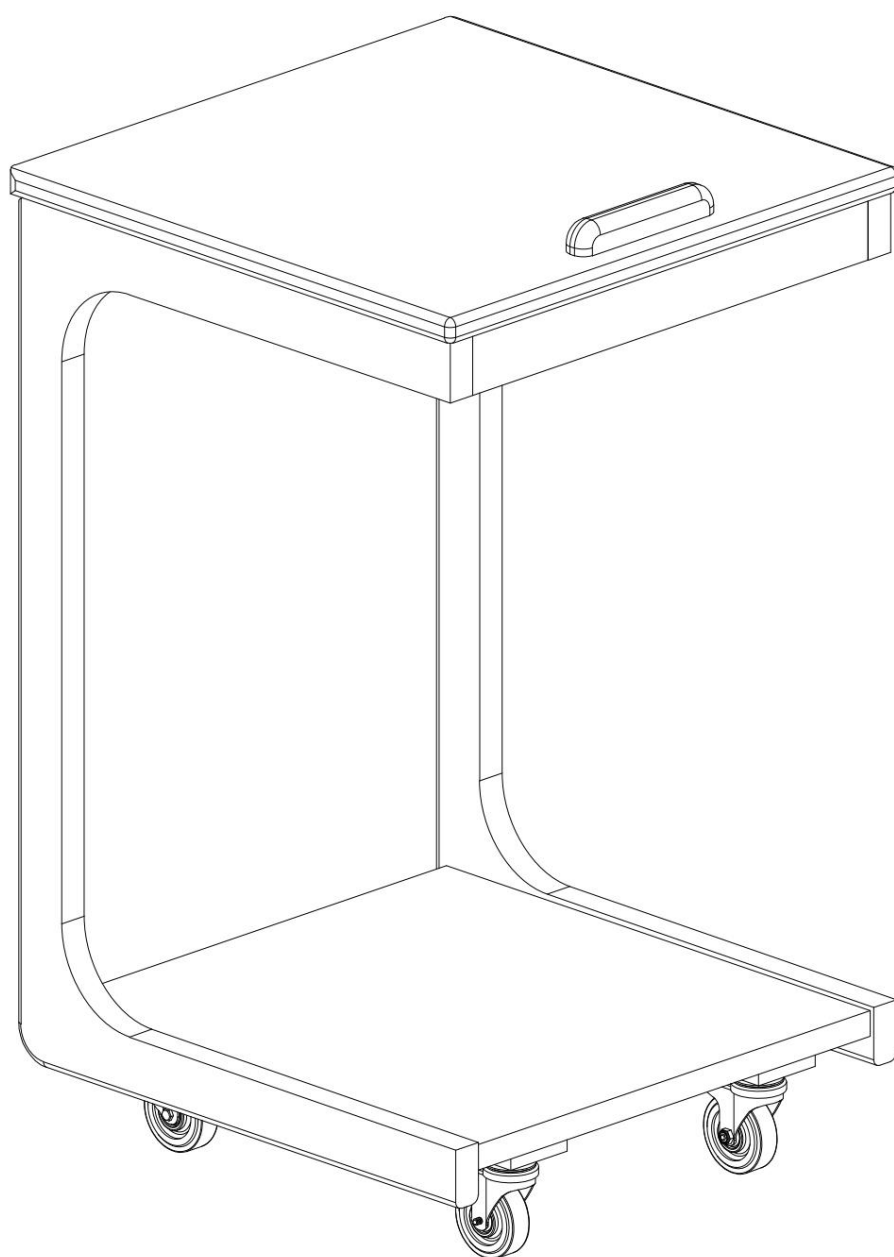



Installation Diagram

Specification
Name:

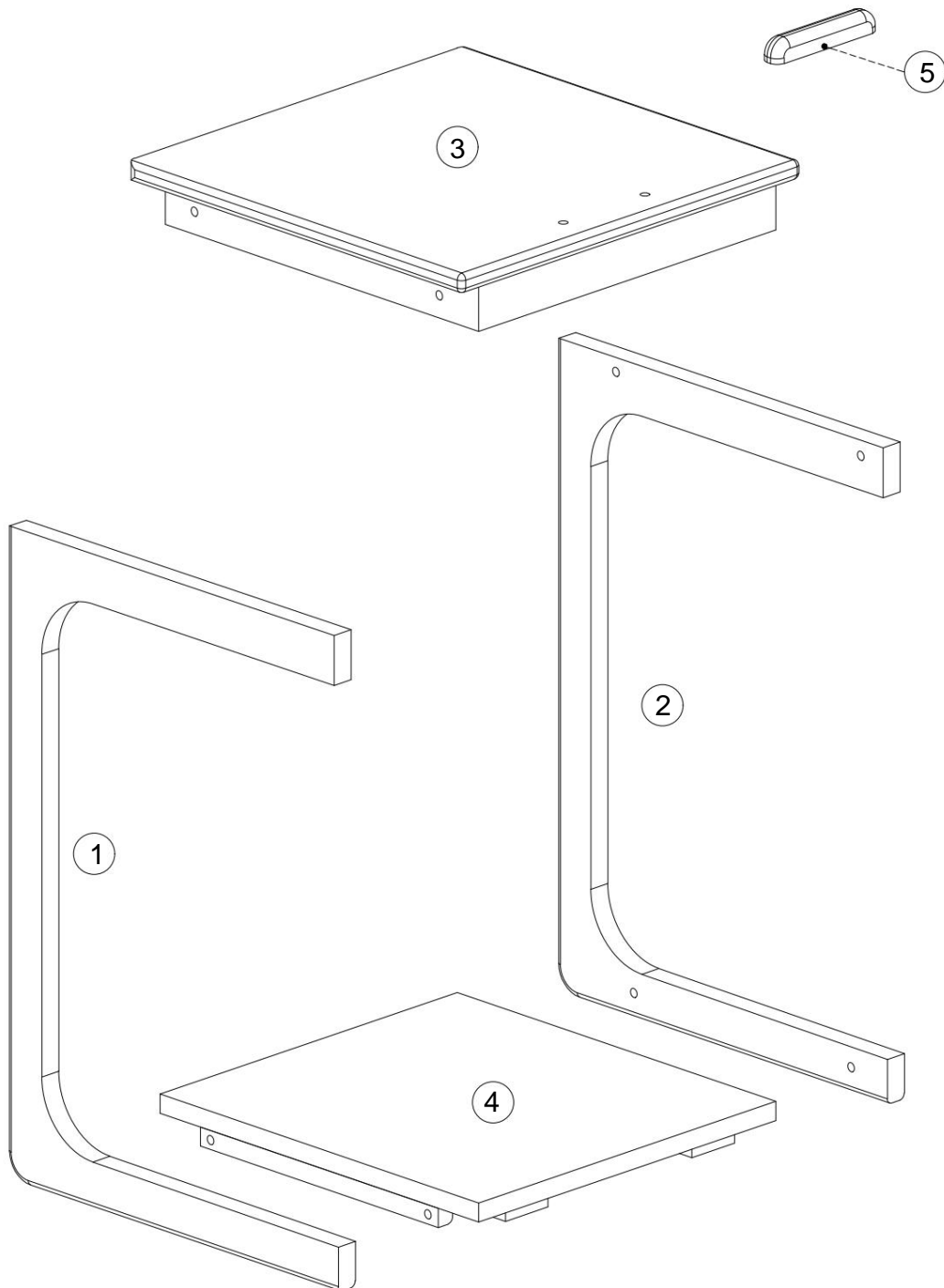
Rolling Side Table 003C Shape 60CM/23.6inch

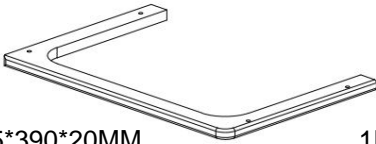
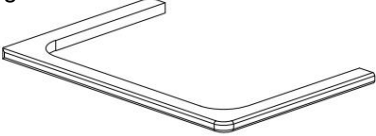
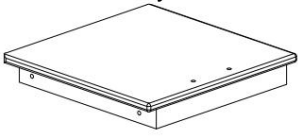
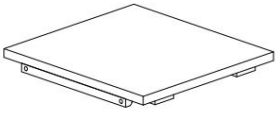

Parts List

<p>① Left Frame</p>  <p>581.5*390*20MM 1PC</p>	<p>② Right Side Frame</p>  <p>581.5*390*20MM 1PC</p>	<p>③ Inner Box Assembly</p>  <p>600*400*57MM 1PC</p>
<p>④ Bottom Plate</p>  <p>550*375*34MM 1PC</p>	<p>⑤ Panel Stop</p>  <p>120*20*20MM 1PC</p>	

Before Use:

1. Open on a soft surface; retain packaging.
2. Count and inspect all parts (no cracks or warping).
3. Problems? Contact the seller through the order page and provide B.J003 + part code + quantity + order ID + photo.
Response time: 24 hours or less. Replacement only.
4. The smell of new goods is normal: ventilate for 24 hours.

Notice

Using the proper screws can prevent damage to these components.

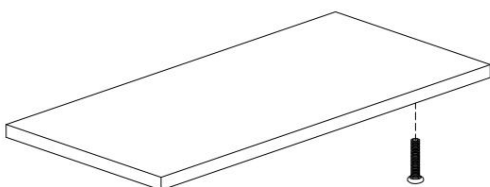

Example

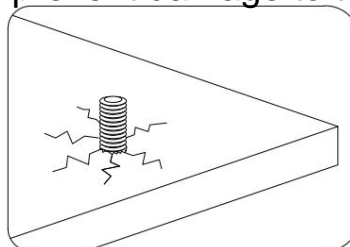



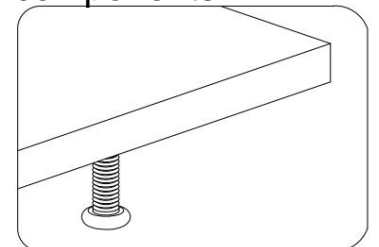



Mistake: Screws can cause boards to split

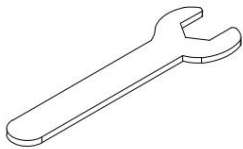

Correct: The screws are the correct size



Hardware List

<p>A open-end wrench</p>  <p>Opening 14MM 1PC</p>	<p>B Threaded Caster with Brake</p>  <p>Ø25MM, total height 43MM 2PCS</p>	<p>C Hexagon socket screw</p>  <p>M6*25MM 8PCS</p>
<p>D Flat gasket</p>  <p>M6*13MM 8PCS</p>	<p>E Hexagon wrench</p>  <p>M4*100*40MM 1PC</p>	<p>F Threaded caster without brake</p>  <p>Ø25MM, total height 43MM 2PCS</p>

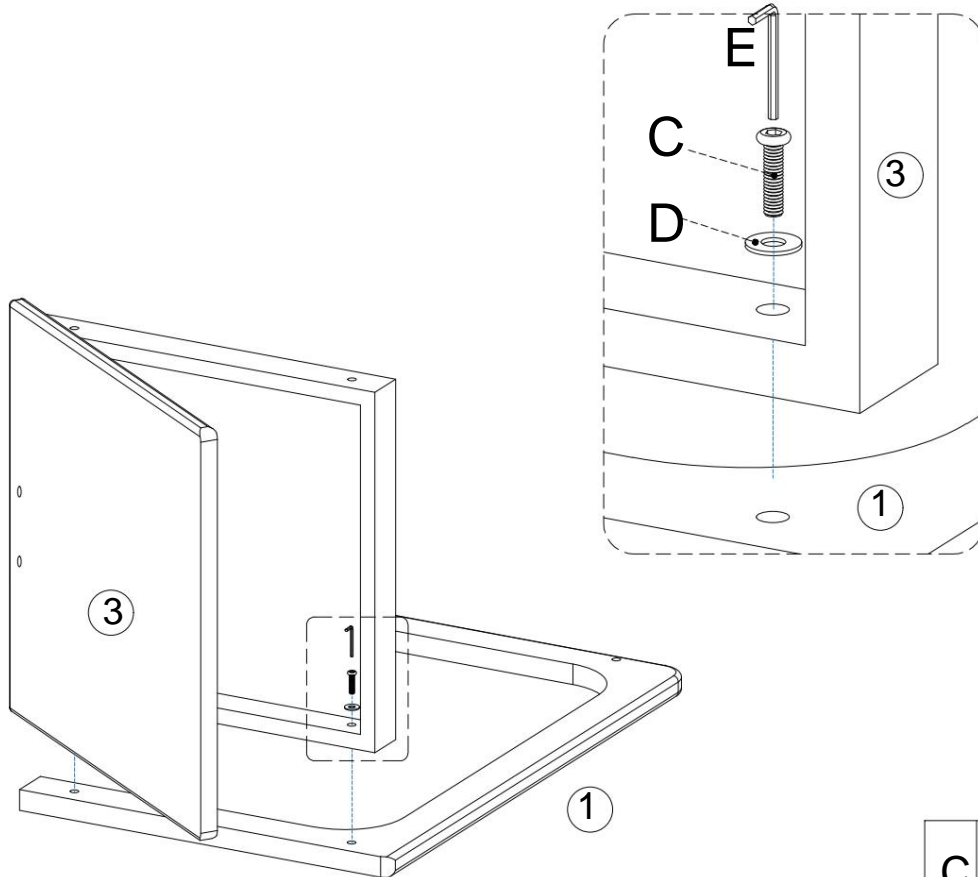
Step 1



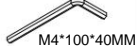

Note: After unpacking, please check the instructions to ensure the correct number of components are in the correct order. Then assemble as shown. Align component 3 with the hole on the end face of component 1 and secure with hardware C/D/E.

C	 M6*25MM	2PCS
D	 M6*13MM	2PCS
E	 M4*100*40MM	1PC

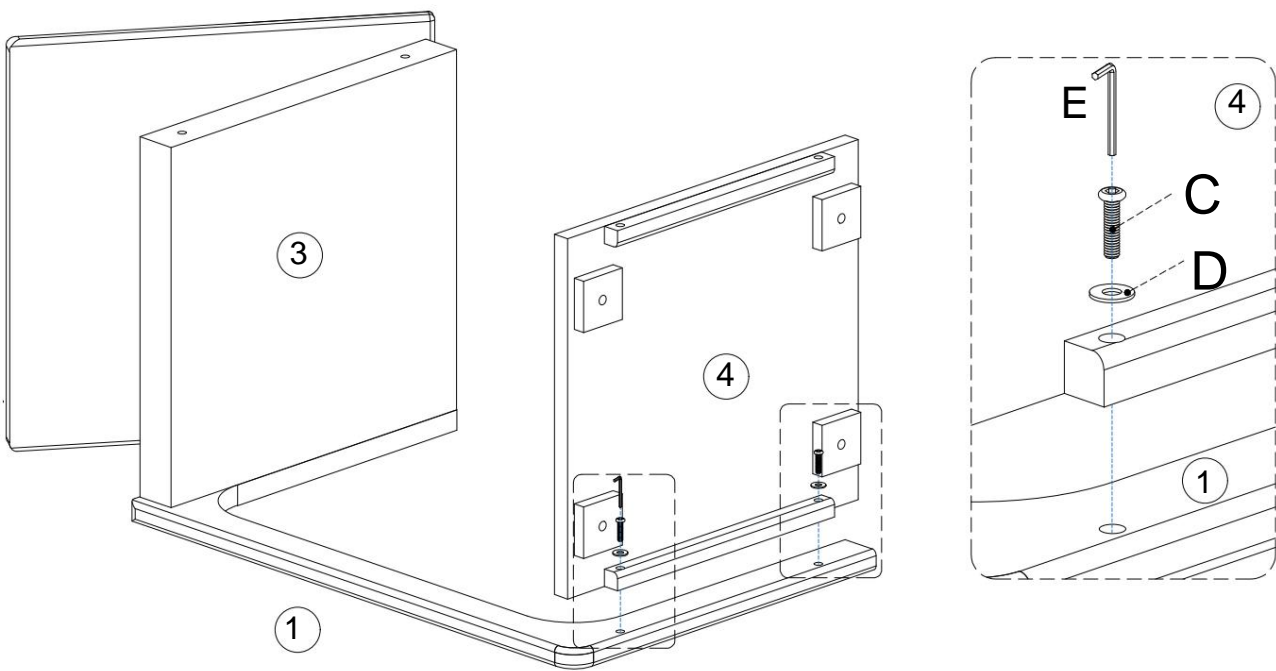
Step 2



As shown in the figure, use hardware C/D/E to connect component 4 to the components assembled in Step 1.

C	 M6*25MM	2PCS
D	 M6*13MM	2PCS
E	 M4*100*40MM	1PC

Specification Name: Rolling Side Table 003 C Shape 60CM/23.6inch

Step 3

Same assembly method as Step1
Connect components 2/3
Pay attention to all holes of parts 2/3/4
Cannot lock if not aligned

Connect parts 2/4 in the same way as Step 2.
Note that all holes of parts 2/3/4 are not aligned and cannot be locked.

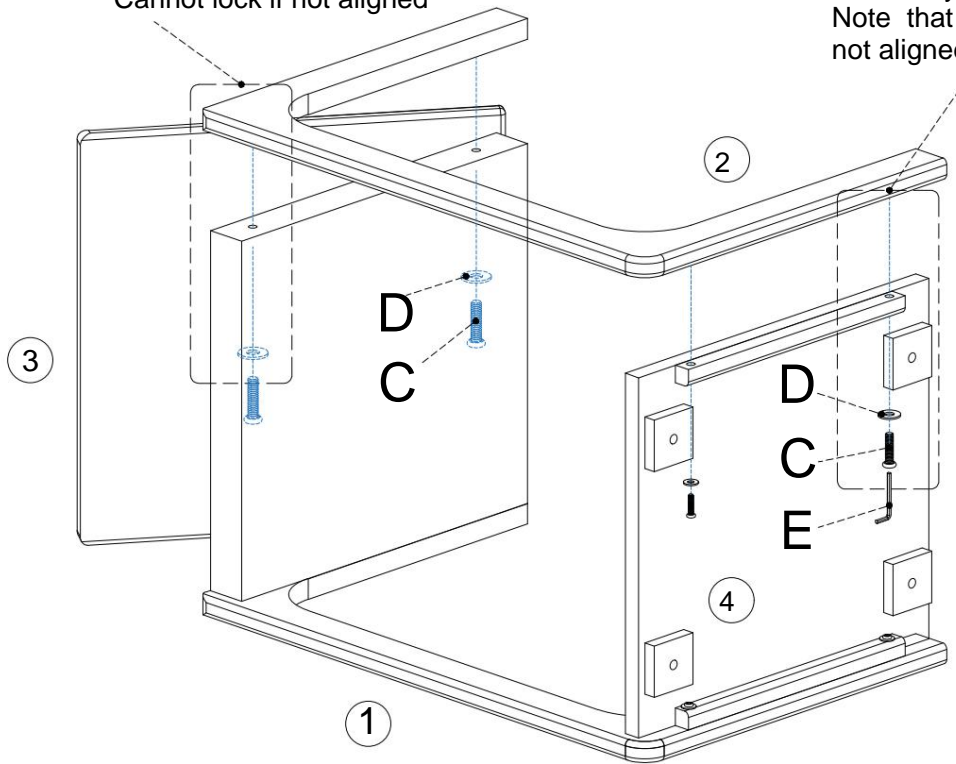

C	M6*25MM	4PCS
D	M6*13MM	4PCS
E	M4*100*40MM	1PC

As shown in the figure, use hardware C/D/E to connect Part 2 to the parts assembled in Step 2. The assembly method is the same as Step 1/Step 2.

Step 4

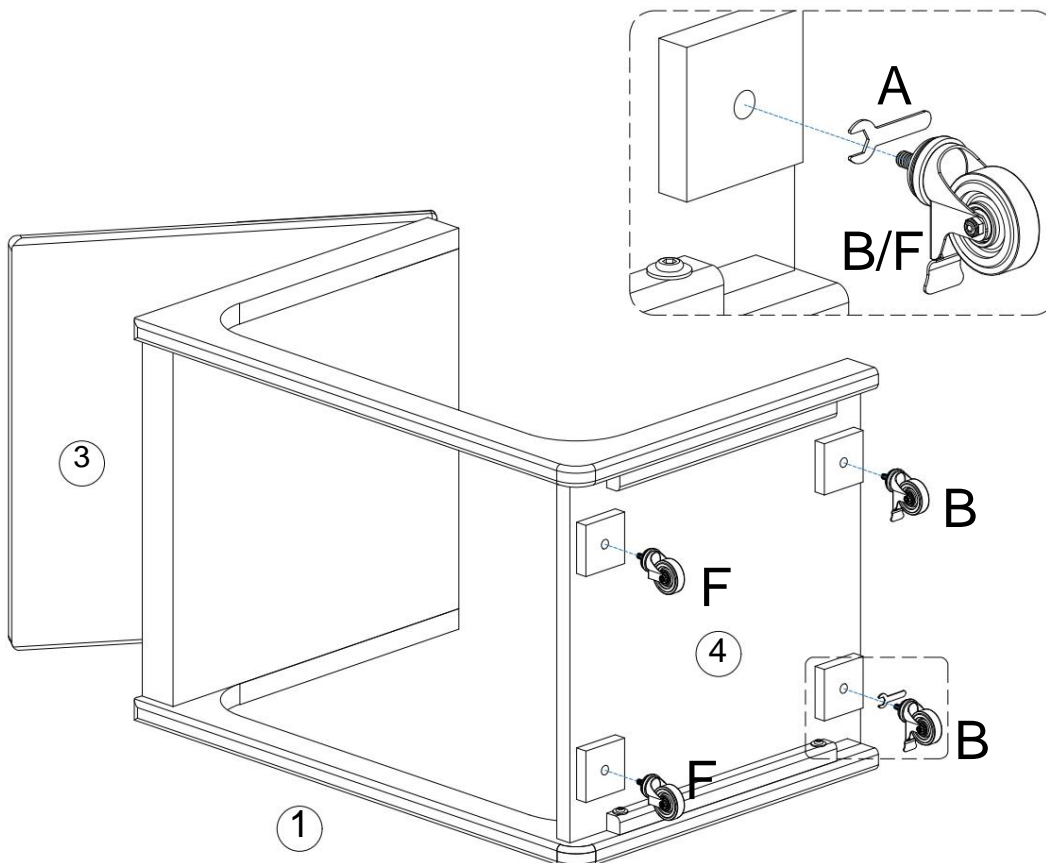

A	Opening 14MM	1PC
B	Ø25MM, total height 43MM, with brake	2PCS
F	Ø25MM Total height 43MM without brake	2PCS

Assemble as shown in the figure, rotate hardware B/F clockwise with hardware A to assemble it to the bottom plate of component No. 4, and pay attention to the position of the hardware casters!!!

Step 5

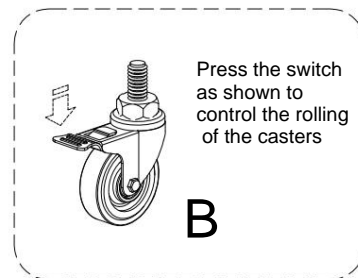
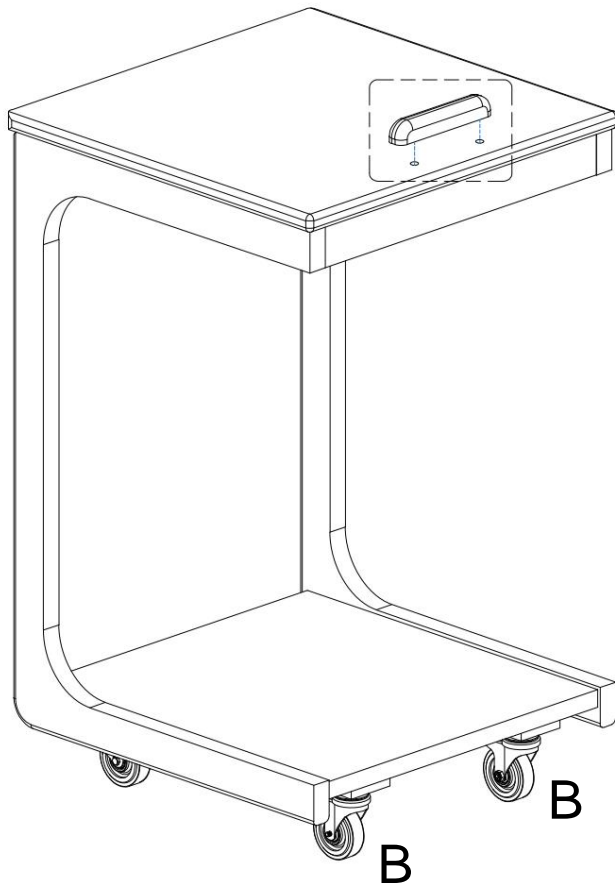
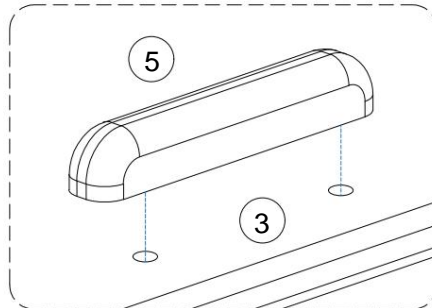

Assemble as shown in the figure, install part 5 on the panel, and the assembly is complete.