

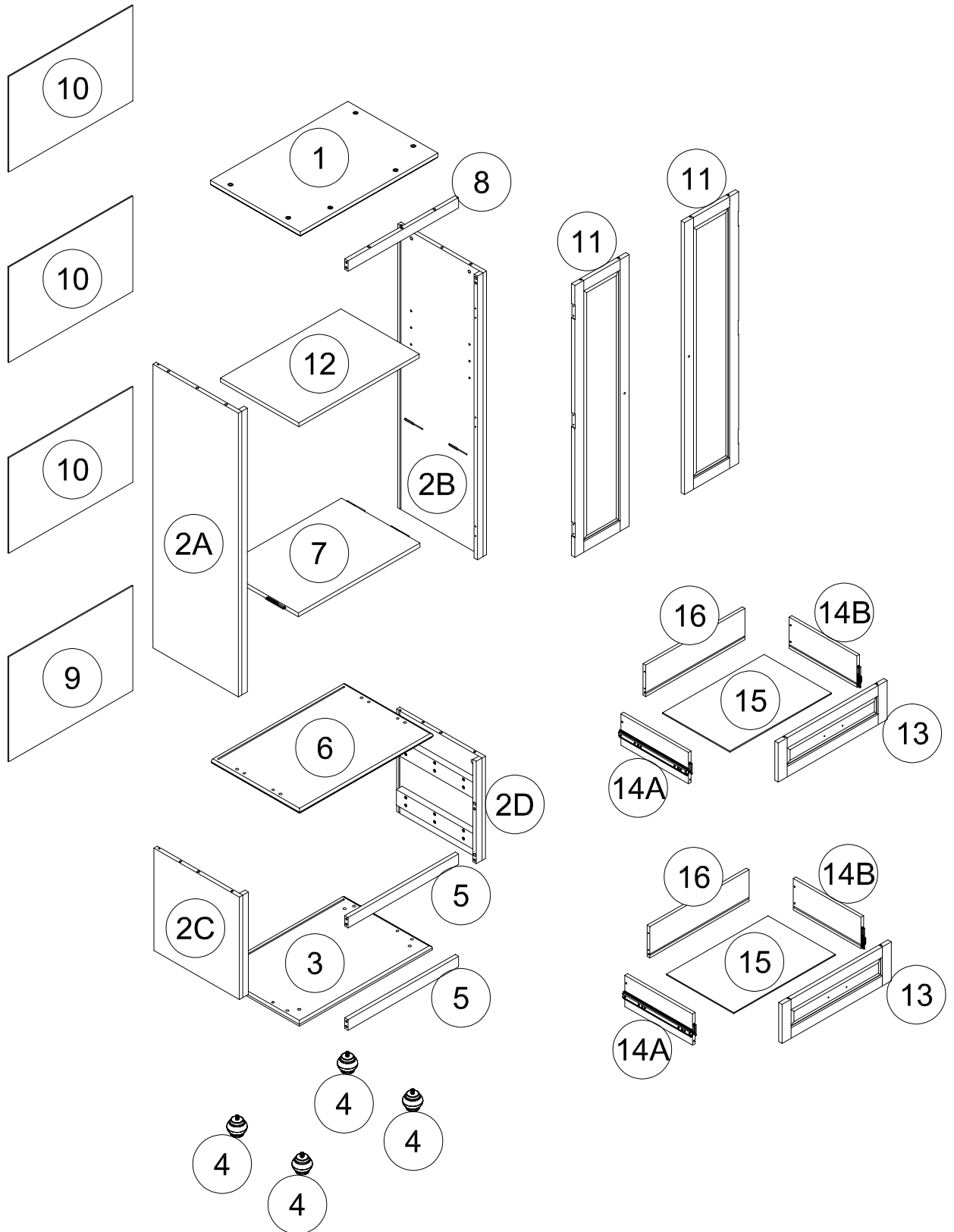





ASSEMBLY INSTRUCTIONS



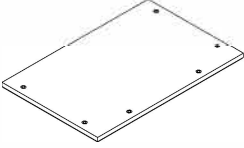
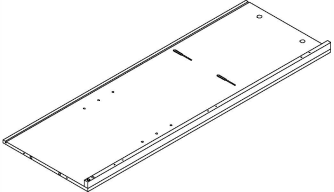
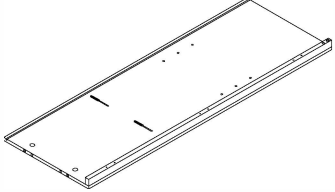
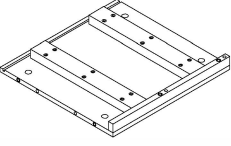
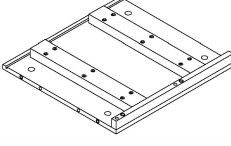
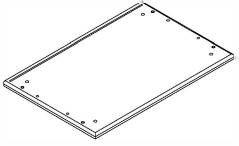

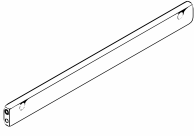
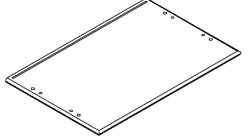

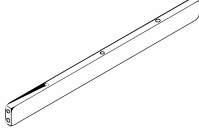
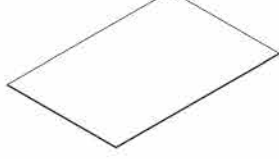

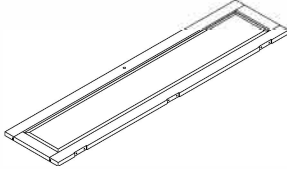
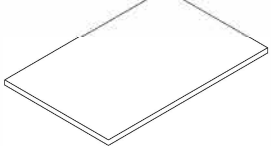
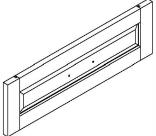
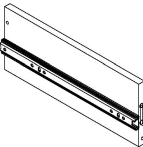
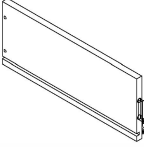
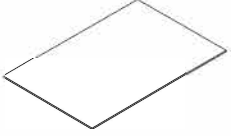
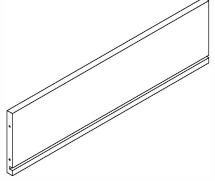



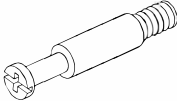
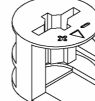
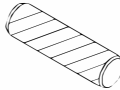
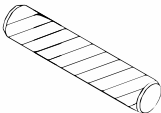
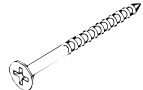

ASSEMBLY INSTRUCTIONS

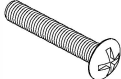

Part List

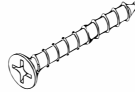
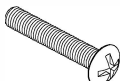
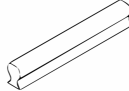
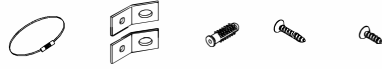
<p>1</p>  <p>Top of Cabinet - 1 pc</p>	<p>2A</p>  <p>Upper left side - 1 pc</p>	<p>2B</p>  <p>Upper right side - 1 pc</p>
<p>2C</p>  <p>Lower left side - 1 pc</p>	<p>2D</p>  <p>Lower right side - 1 pc</p>	<p>3</p>  <p>Bottom of the cabinet - 1 pc</p>
<p>4</p>  <p>Cabinet legs - 4 pcs</p>	<p>5</p>  <p>Horizontal bar - 2 pcs</p>	<p>6</p>  <p>Middle of the cabinet - 1 pc</p>
<p>7</p>  <p>Fixed shelf - 1 pc</p>	<p>8</p>  <p>Horizontal bar - 1 pc</p>	<p>9</p>  <p>Lower back panels - 1 pc</p>
<p>10</p>  <p>Upper back panels - 3 pcs</p>	<p>11</p>  <p>Cabinet door - 2 pcs</p>	<p>12</p>  <p>Adjustable shelf - 1 pc</p>
<p>13</p>  <p>Drawer - Front side - 2 pcs</p>	<p>14A</p>  <p>Drawer - Side rails - 2 pcs</p>	<p>14B</p>  <p>Drawer - Side rails - 2 pcs</p>
<p>15</p>  <p>Drawer - Bottom Panels - 2 pcs</p>	<p>16</p>  <p>Drawer - Back Panels - 2 pcs</p>	

Hardware List

<p>A</p>  <p>Cam Bolt 18 pcs</p>	<p>B</p>  <p>Cam Lock 10mm 18 pcs</p>	<p>C</p>  <p>Ø8 x 30 mm Wood dowel 15 pcs</p>
<p>D</p>  <p>Ø8 x 60 mm Wood dowel 4 pcs</p>	<p>E</p>  <p>M4 x 50 mm Wood Screws 2 pcs</p>	<p>F</p>  <p>1/4" x 50 mm Wood Screws 4 pcs</p>
<p>G</p>  <p>Plastic Wedges 24 pcs</p>	<p>H</p>  <p>M4 x 20 mm Wood Screws 48 pcs</p>	<p>I</p>  <p>Hinge 6 pcs</p>
<p>J</p>  <p>M4 x 20 mm Truss Head Wood Screws 2 pcs</p>	<p>K</p>  <p>Cabinet Door Handle 2 pcs</p>	<p>L</p>  <p>Shelf Pin 9mm 4 pcs</p>
<p>M</p>  <p>M4 x 15 mm Wood Screws 4 pcs</p>	<p>N</p>  <p>M4 x 30 mm Wood Screws 8 pcs</p>	<p>O</p>  <p>M4 x 12 mm Truss Head Wood Screws 4 pcs</p>
<p>P</p>  <p>Drawer Handles 2 pcs</p>	<p>Q</p>  <p>1 2 3 4 5 Antifall 2 sets</p>	<p>R</p>  <p>Allen Key 1 pc</p>
<p>T</p>  <p>Drawer slide 4 pcs</p>	<p>U</p>  <p>M3.5 x 15 mm Wood Screws 16 pcs</p>	

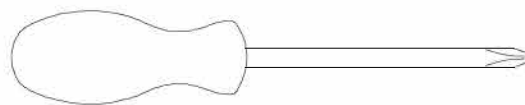

Assembly Tools Required (Not Included)

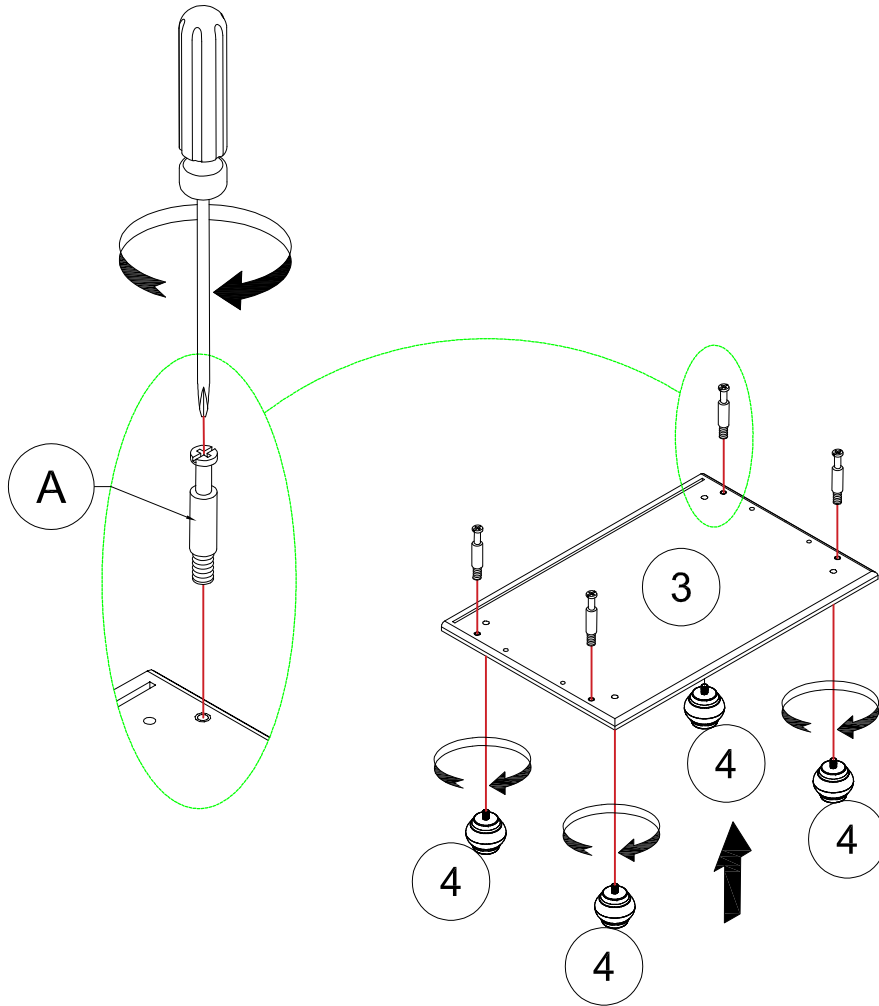

Step 1:

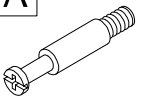

A	
4pcs	

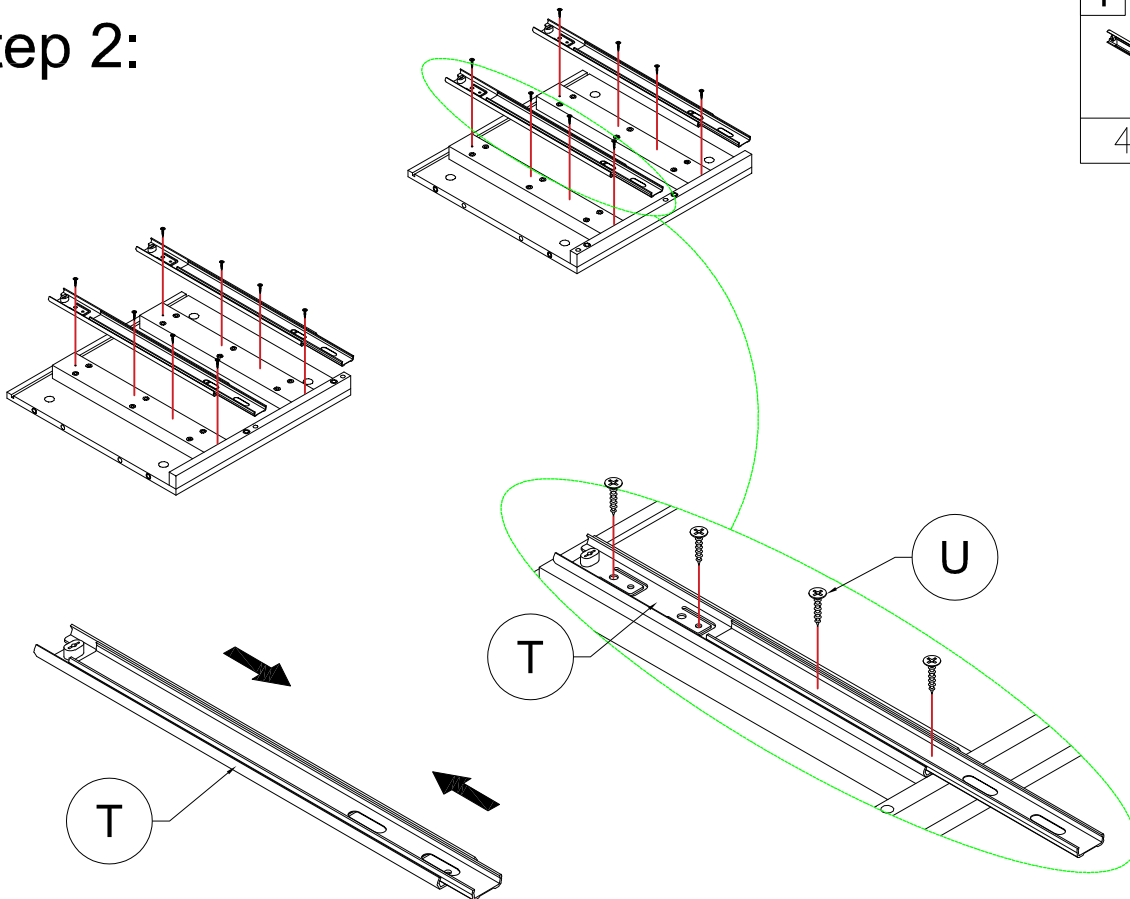
Step 2:



T	U
	
4pcs	16pcs

Move the slide rail to screw in

Step 3:

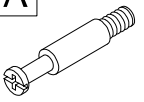
A	
4pcs	

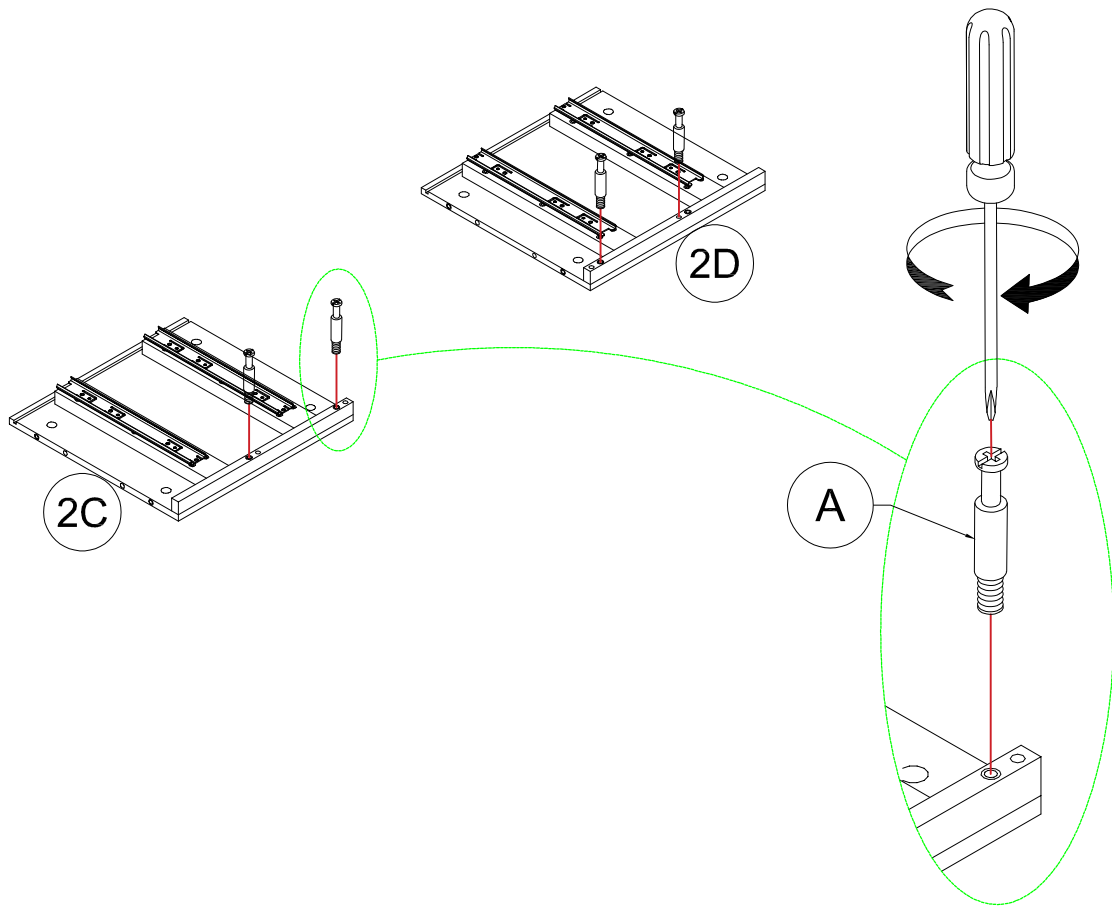

Step 4:

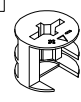
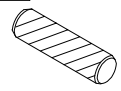
B		C	
4pcs		4pcs	

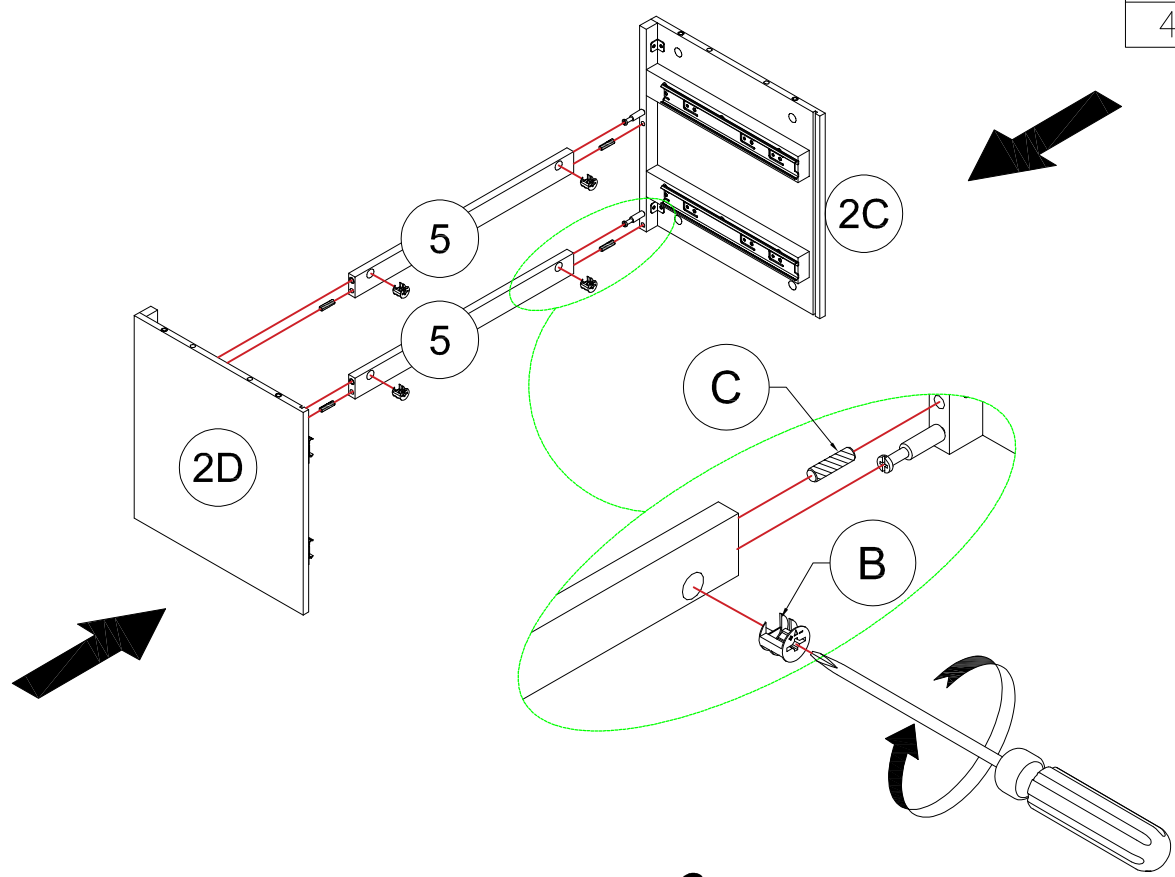

Step 5:

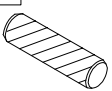
B		C	
4pcs		4pcs	

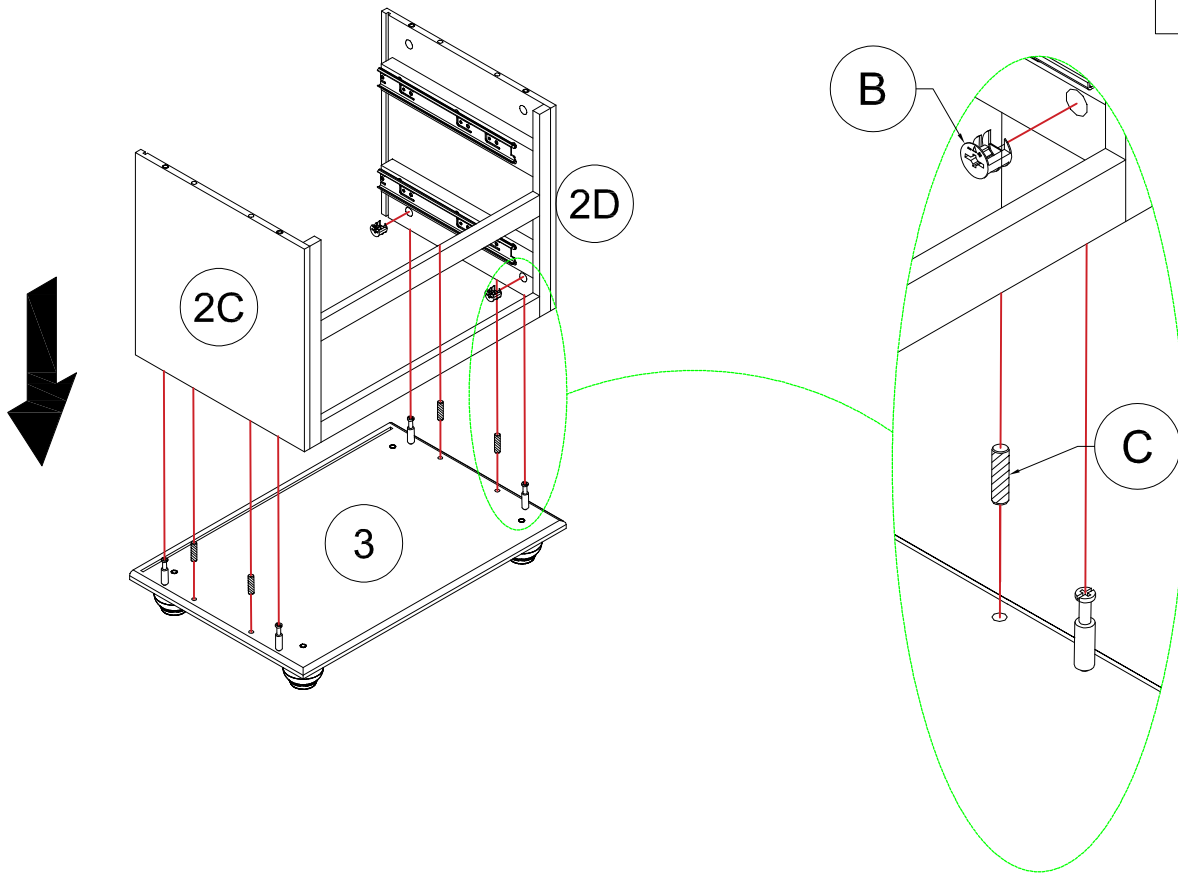

Step 6:

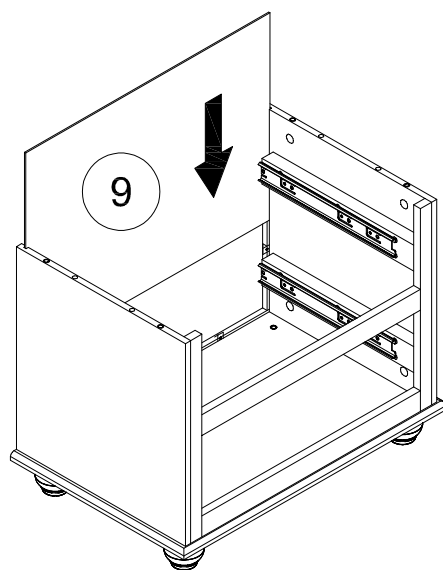

Step 7:

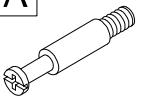
A	
4pcs	

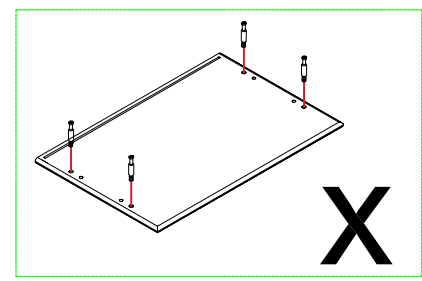
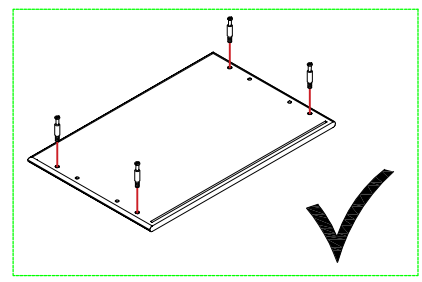
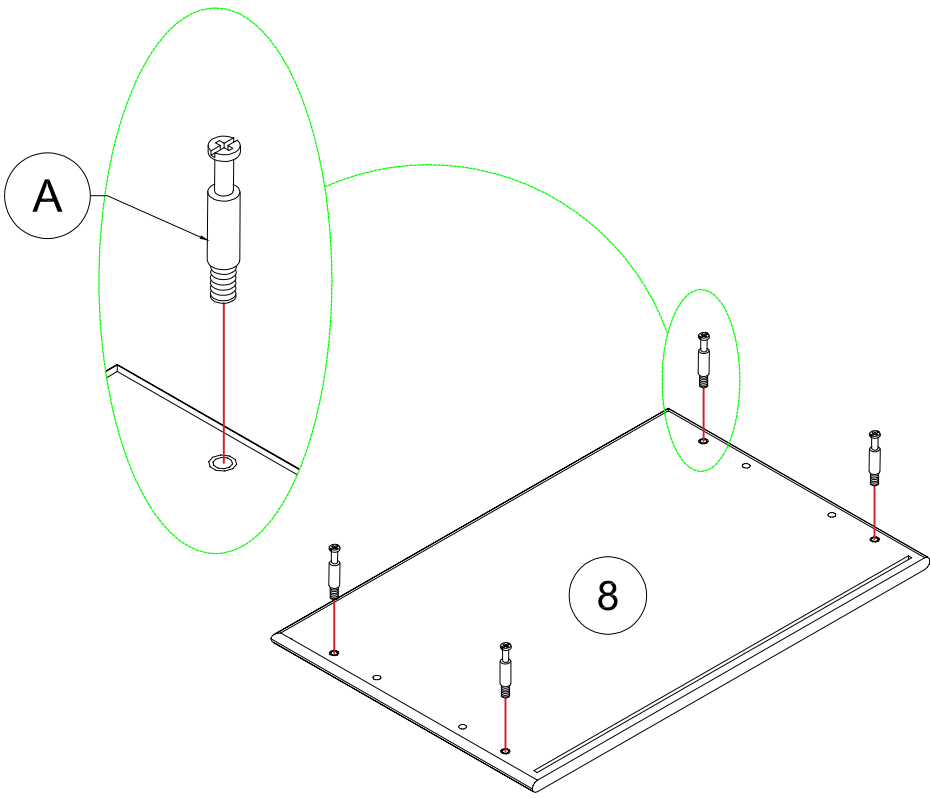

Step 8:

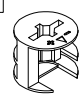
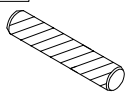
B		D	
4pcs		4pcs	

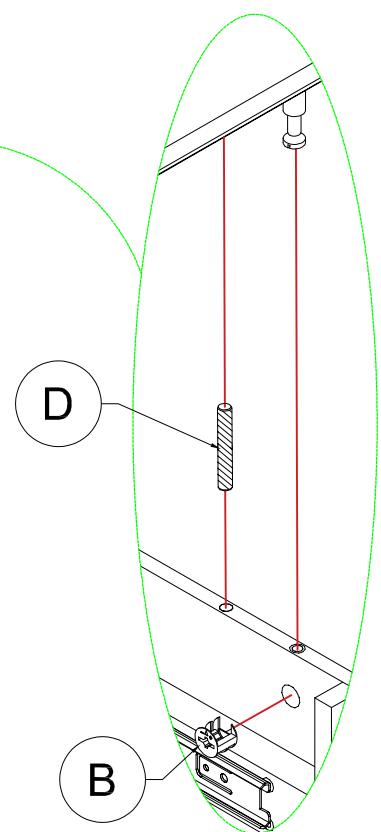
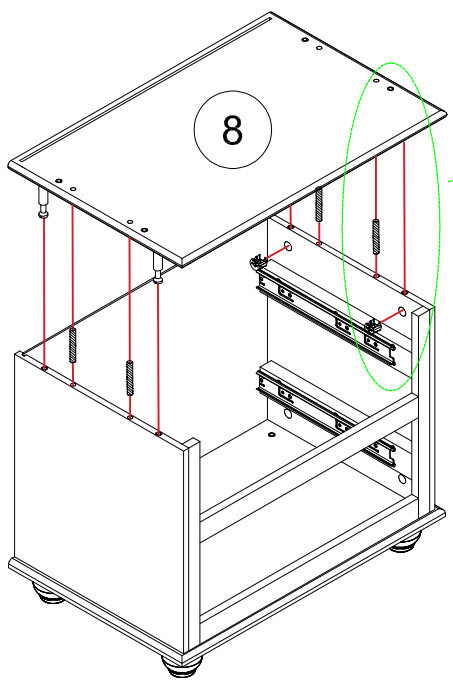
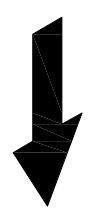

8

Step 9:

A

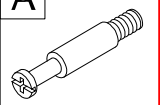

4pcs

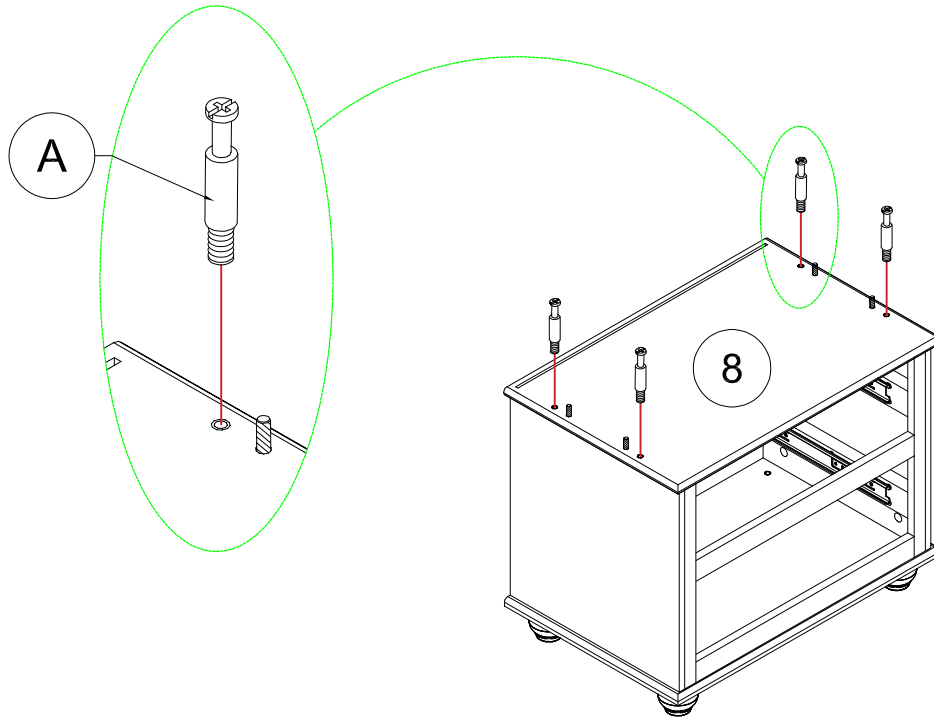

Step 10:

A

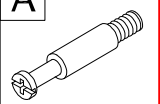

2pcs

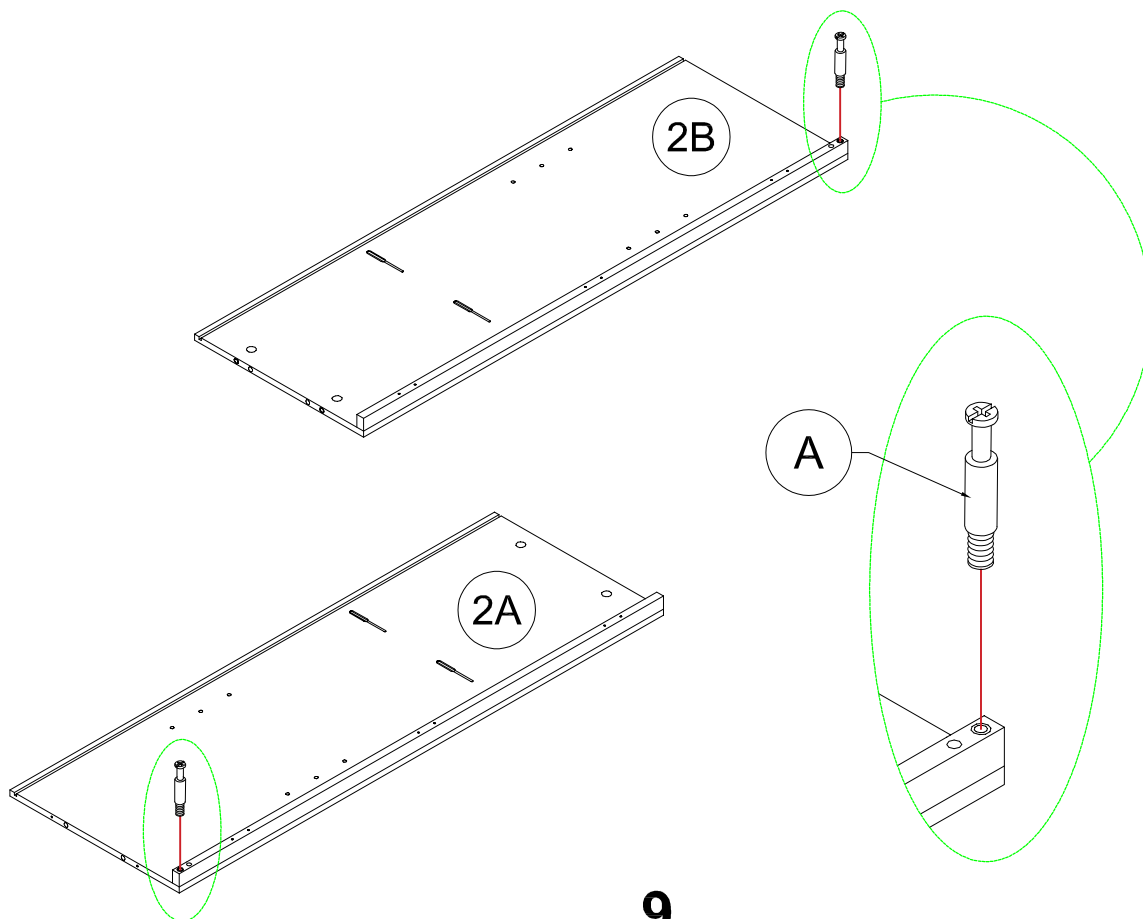

Step 11:

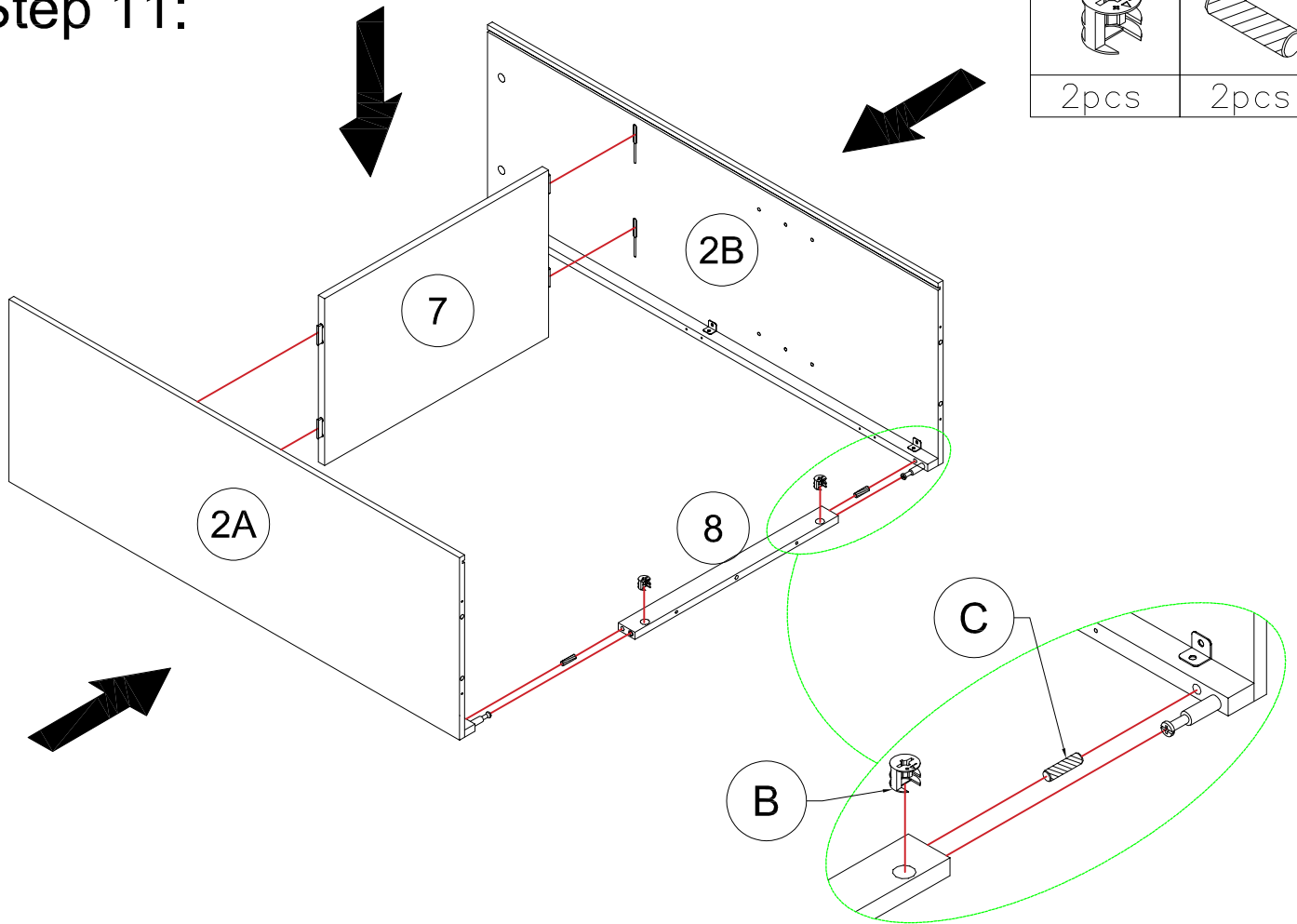

Step 12:

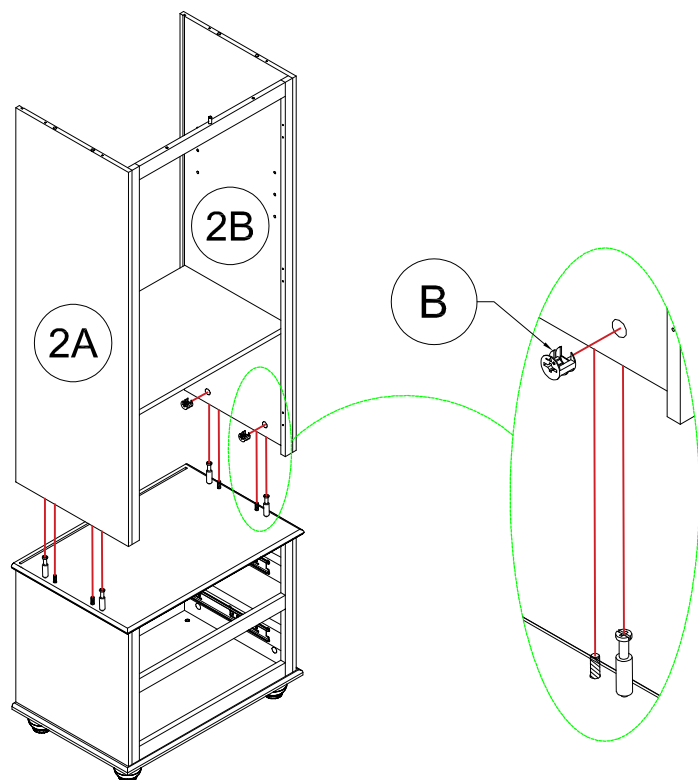

Step 13:

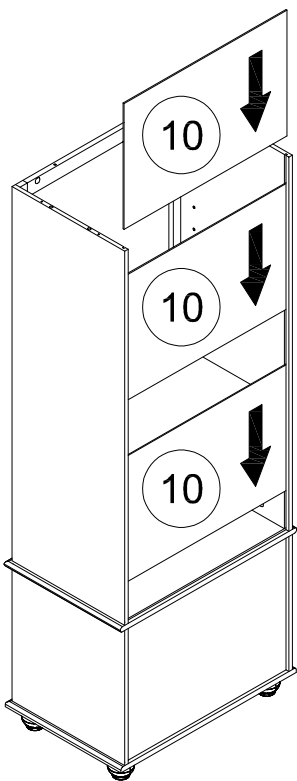

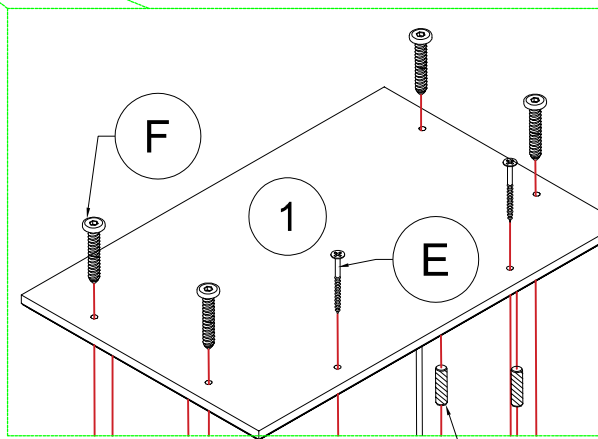
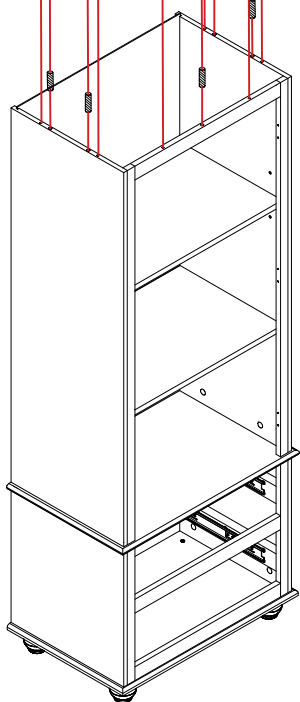
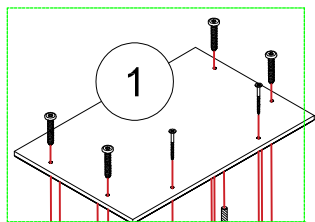
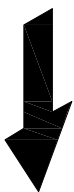

Step 14:

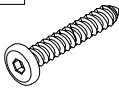
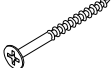
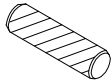

F	E	C
		
4pcs	2pcs	5pcs

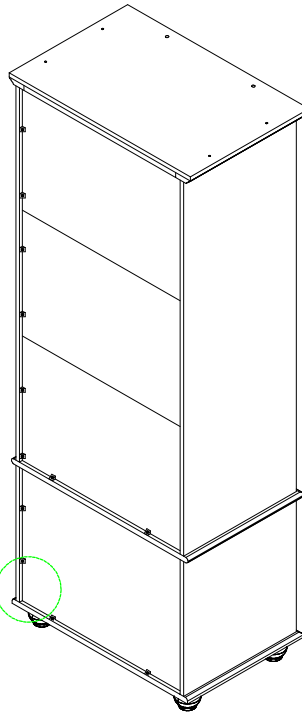
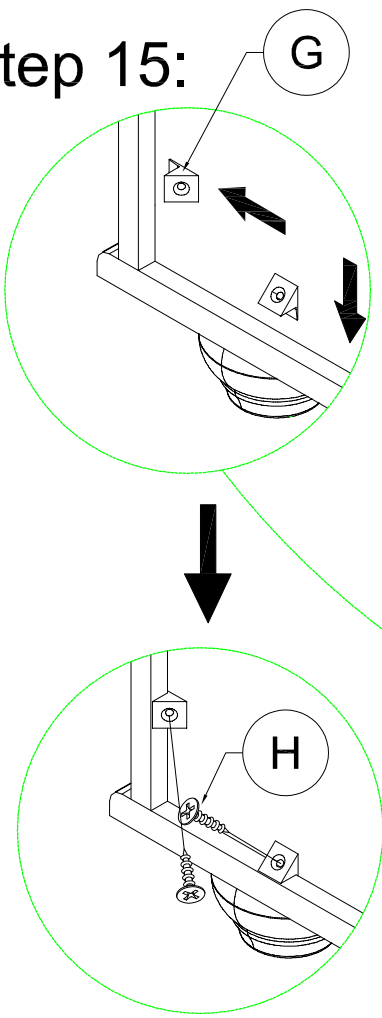
Step 15:

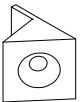

H	G
	
24pcs	24pcs

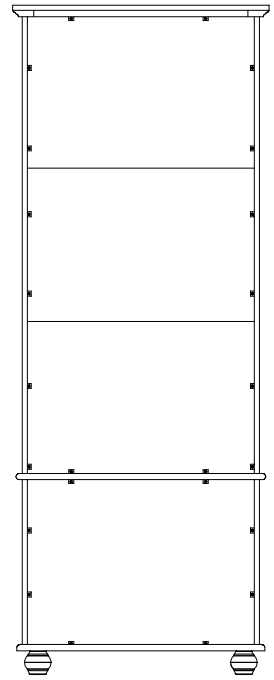

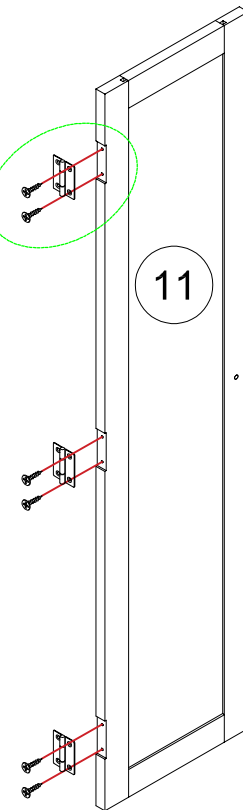
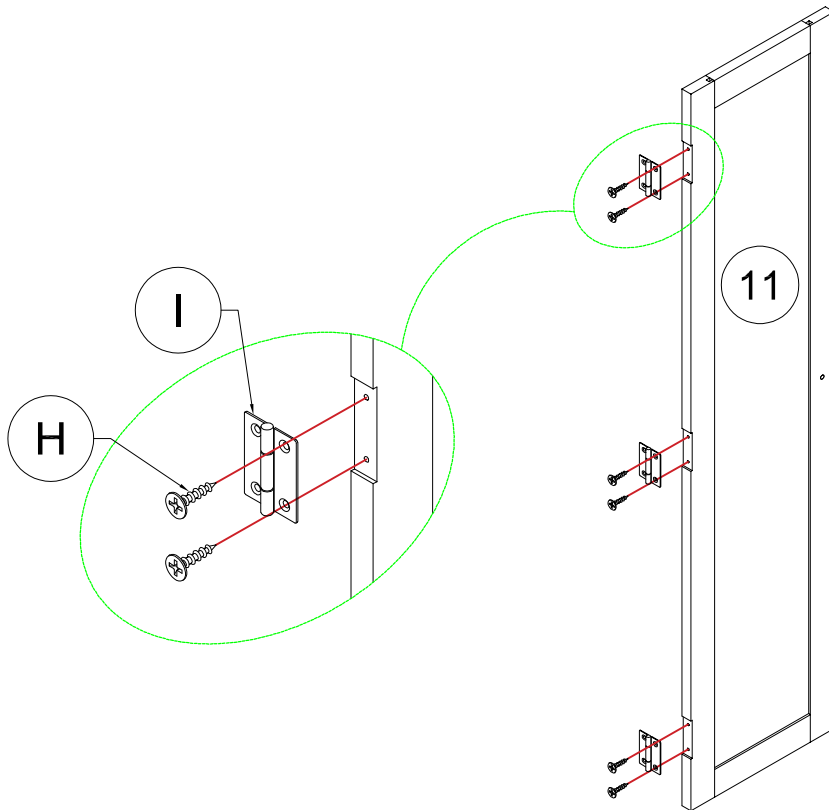

Step 16:

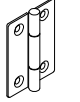

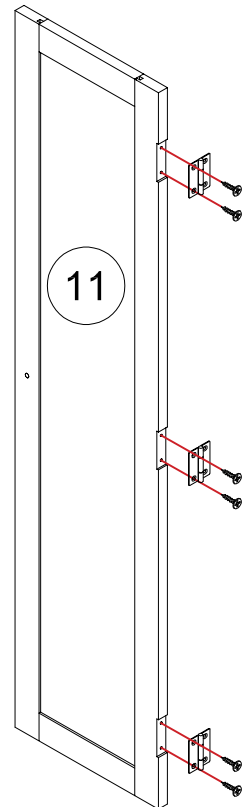
H	I
	
12pcs	6pcs



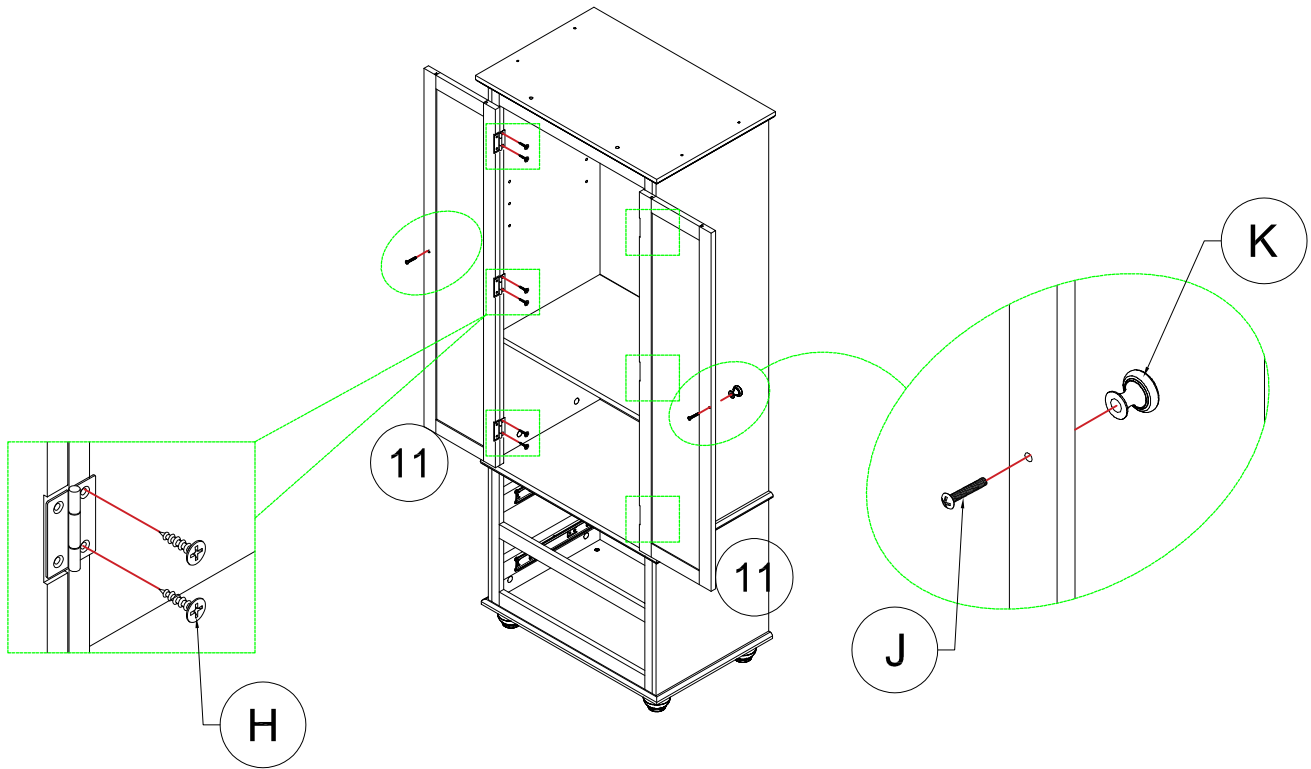

Step 17:

K 	J 	H 
2pcs	2pcs	12pcs

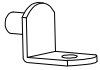

Step 18:

L 	M 
4pcs	4pcs

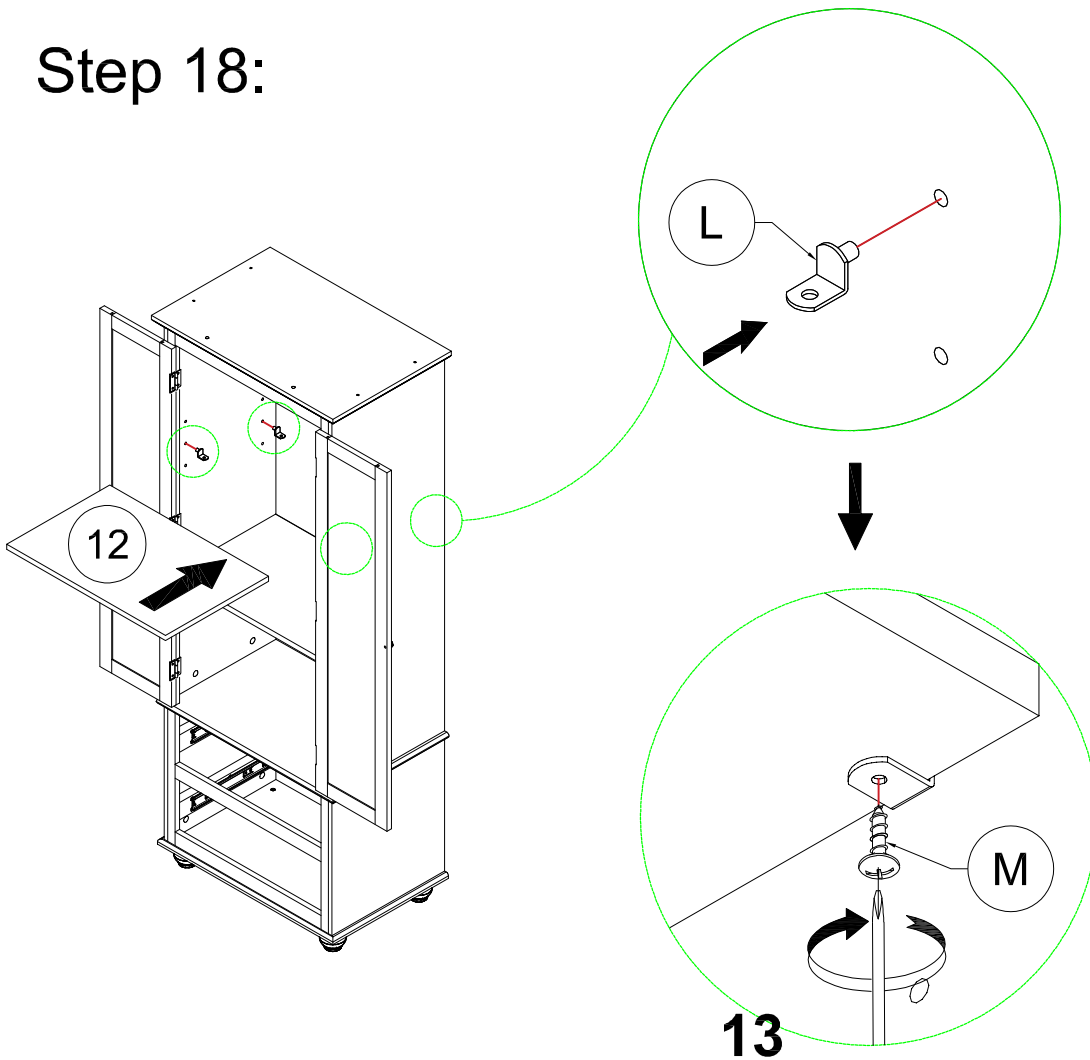

Step 19:

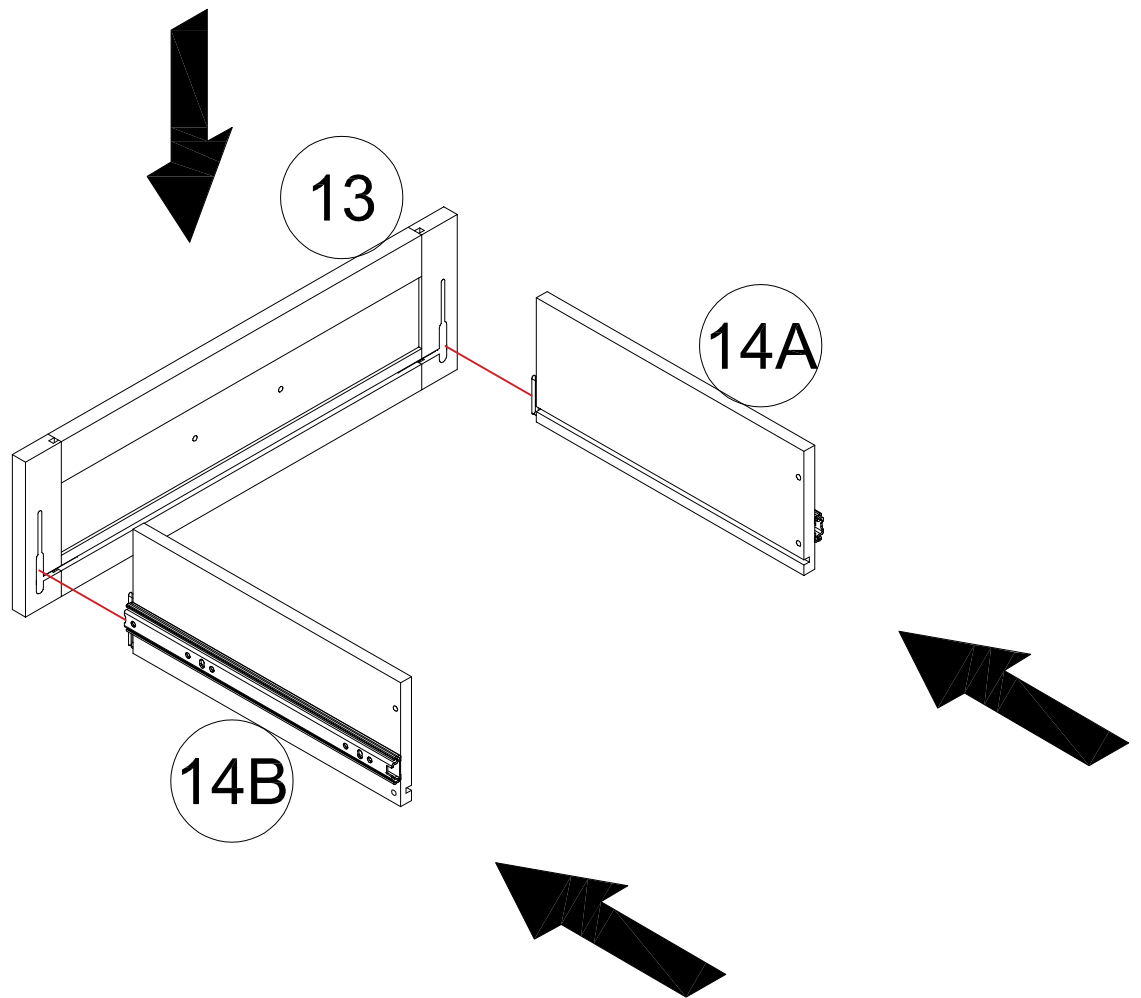

X2

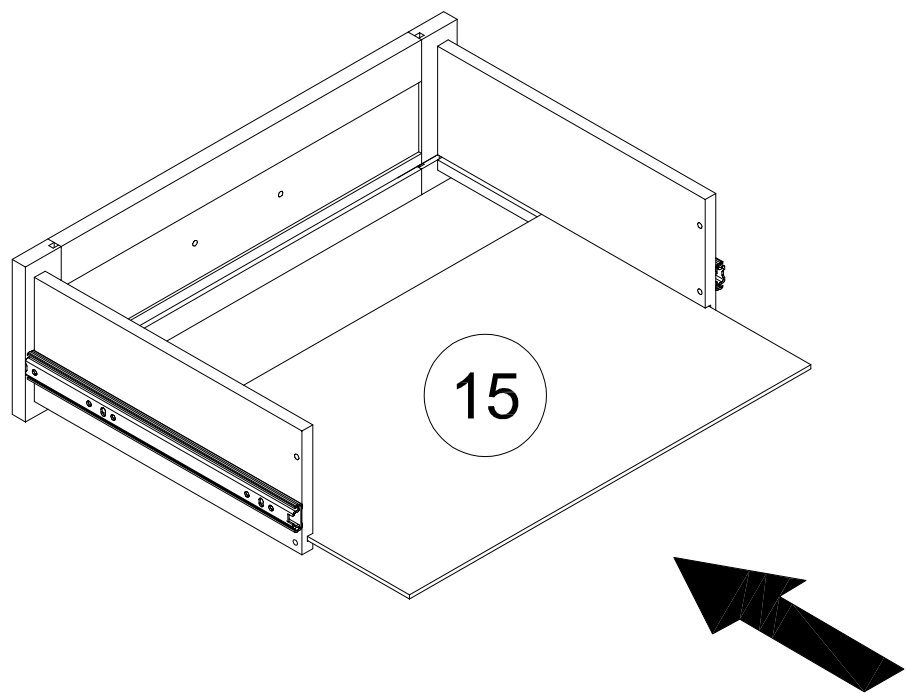

Step 20:



X2

14

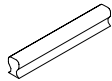
Step 21:

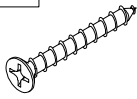
P	O	N
		
2pcs	4pcs	8pcs

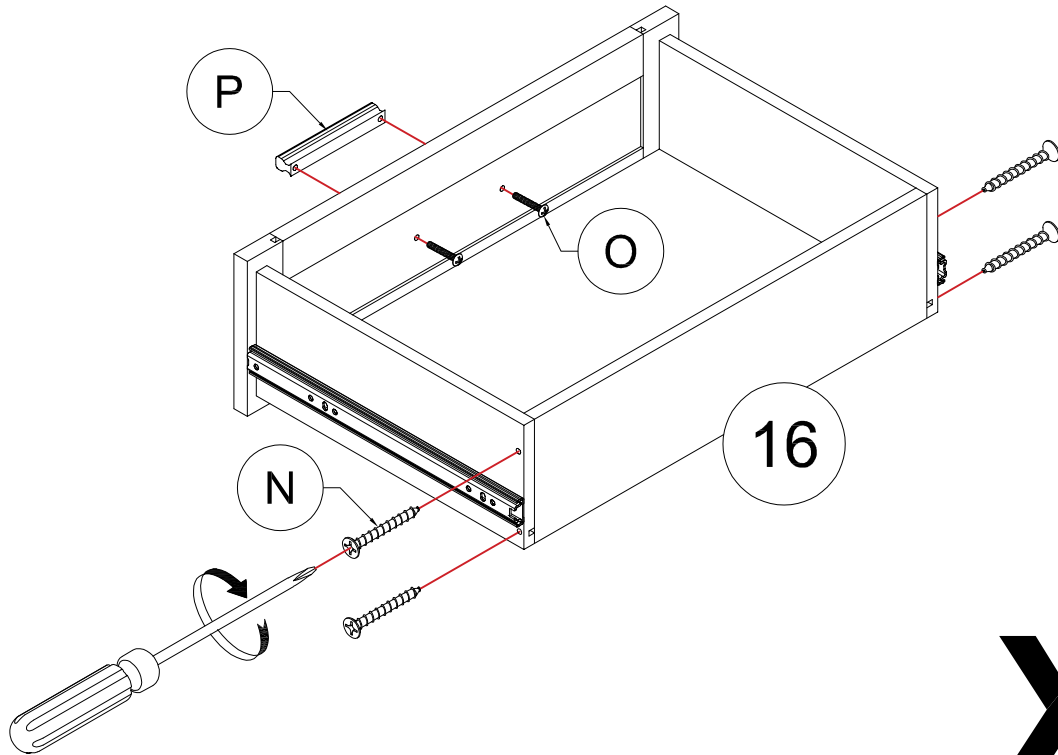

X2

Step 22:

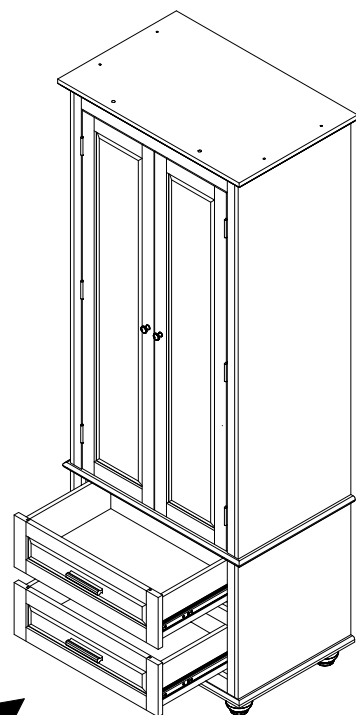
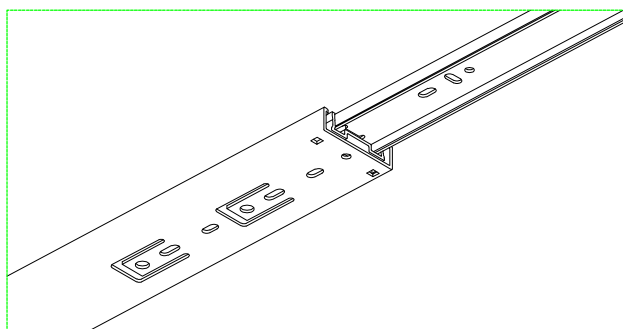
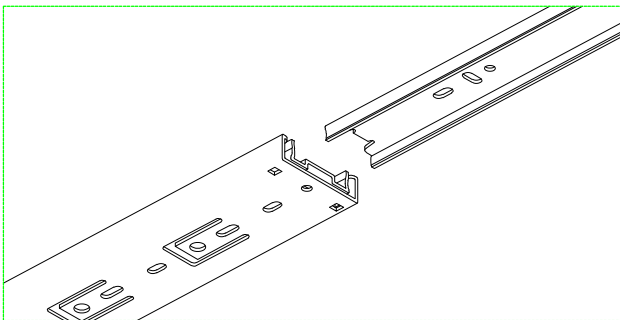

15



Step 23:

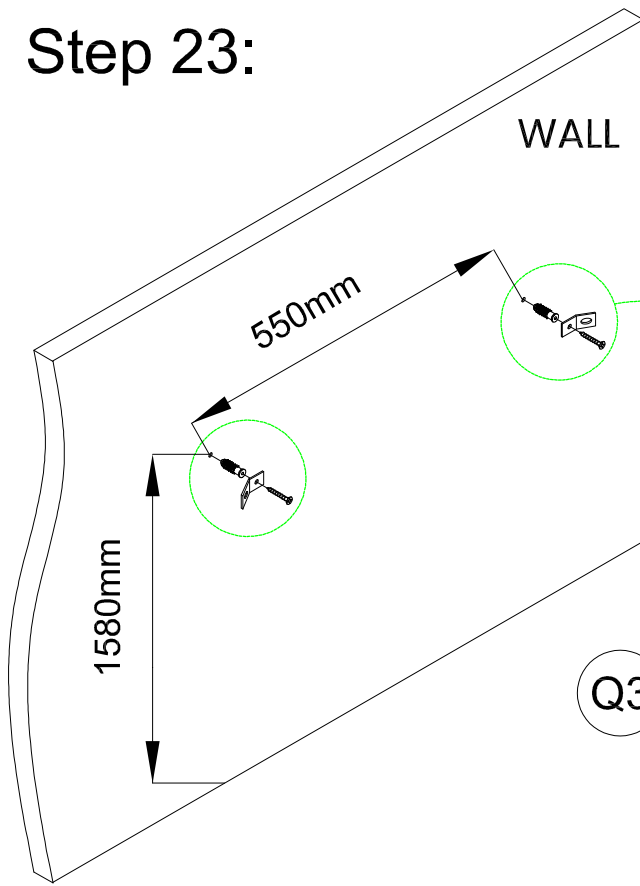

Q-2	Q-3	Q-4
2pcs	2pcs	2pcs

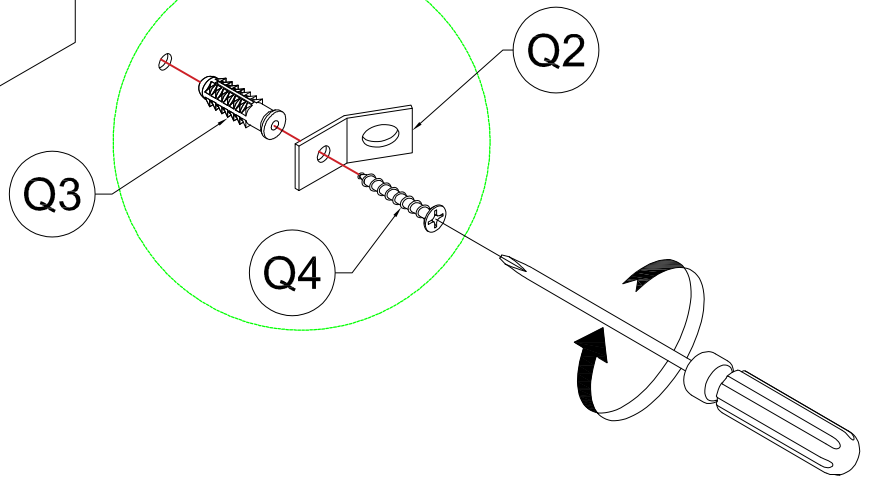

Step 24:

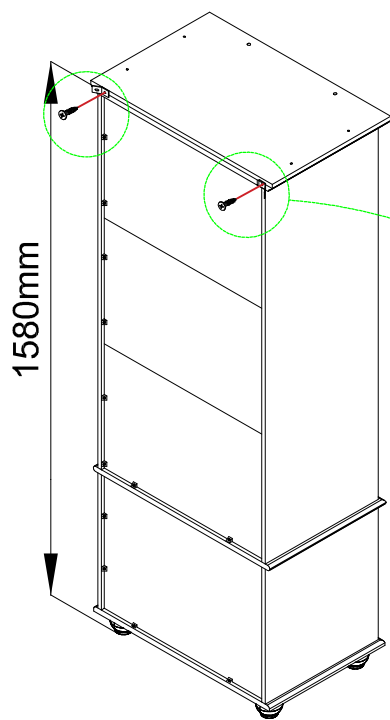

Q-2	Q-5
2pcs	2pcs

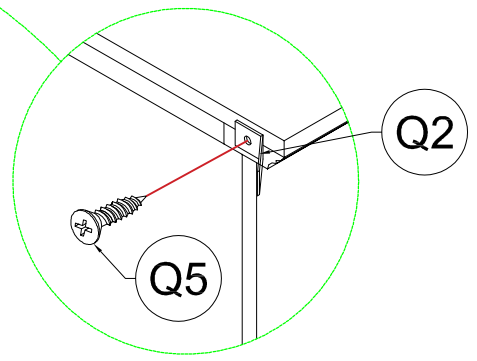

Step 25:

Q-1



2pcs

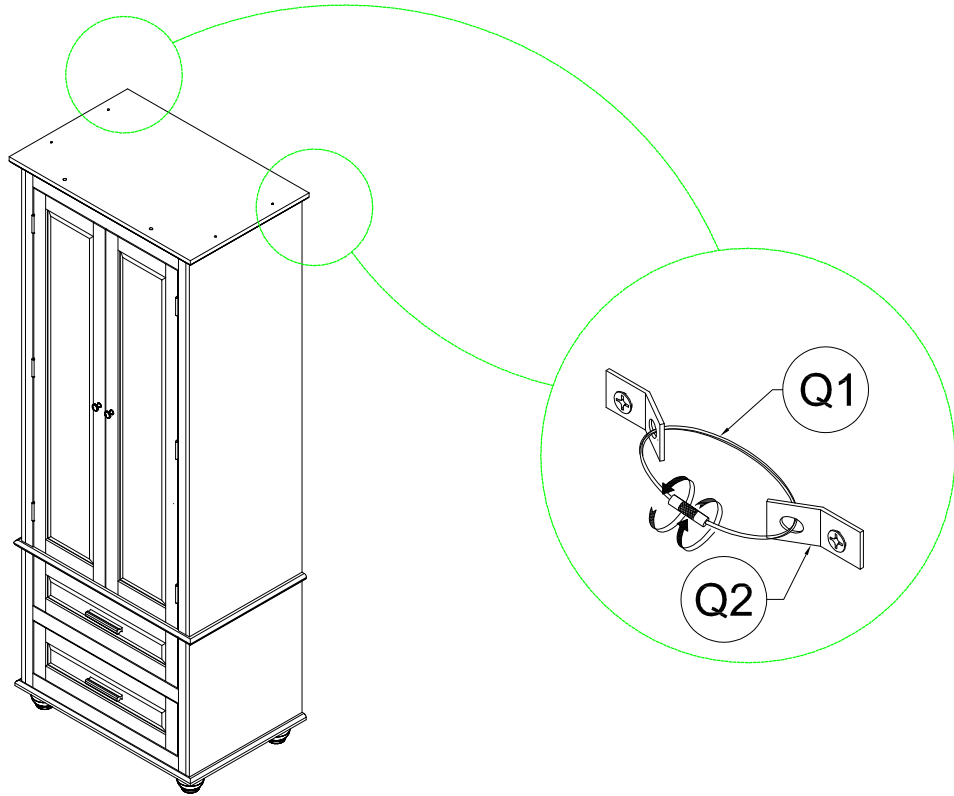

FINISH

