

ASSEMBLING & INSTALLATION INSTRUCTIONS PRODUCT CEILING MOUNT FIXTURE

WARNING! SHUT POWER OFF AT FUSE OR CIRCUIT BREAKER .

ASSEMBLING THE FIXTURE (Fig.1)

1. Shut off the power at the circuit breaker box. Remove old fixture and all hardware from Junction Box. **The junction box is not include.**
2. Carefully unpack your new fixture and lay out all the parts on a clear area. Take care not to lose any small parts necessary for installation.
3. Thread the two box screws about 1/4" into the pre-drilled holes in the mounting plate spaced the same distance apart as the holes in the fixture body(A).
4. Attach the mounting plate to the Junction Box with the two Junction Box Screws as shown. The side of the mounting plate marked "GND" must face out.
5. Raise the fixture body(A) onto the junction box, aligning screws on mounting plate with mounting holes in fixture body(A) and lock it securely with the ball nut (F).
6. Thread the pipe nipple(B) into the bottom center coupling of the lamp holder and lock it securely with the hex nut. Thread lock hex nut onto the end of the pipe nipple.
7. Install the light bulbs in accordance with the fixture specifications
NOTE: DO NOT EXCEED THE SPECIFIED WATTAGE!
8. Raise the steel shim(C) and acrylic plate(D) to bottom of the shade, aligning the hole with pipe nipple and lock it securely with the finial (E).

Your installation is now complete. Return power to the junction box and test the fixture.

Fig.1

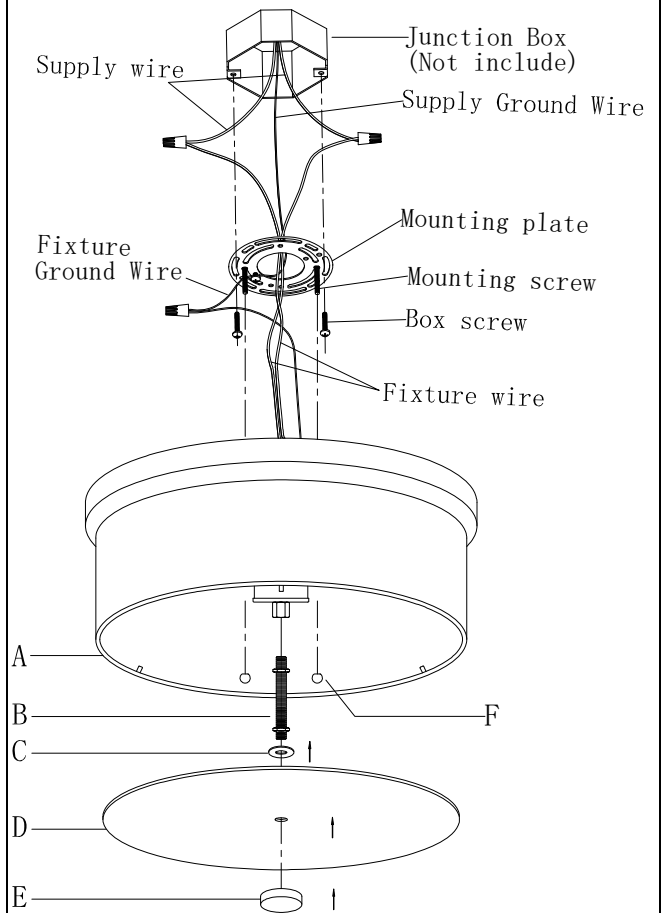

Fig.2

