











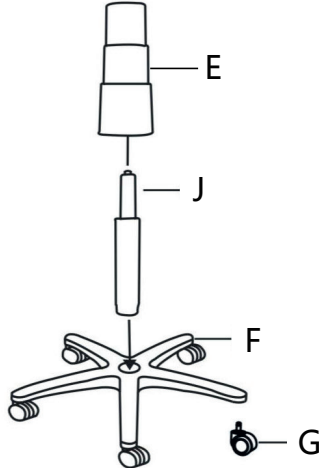
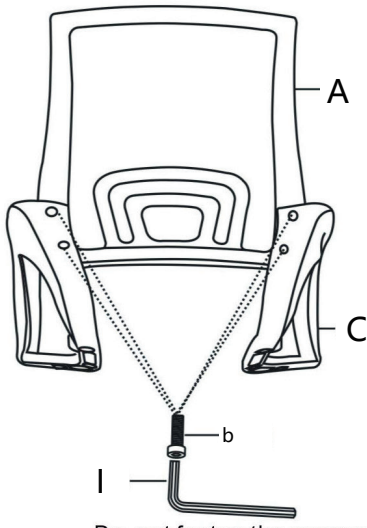
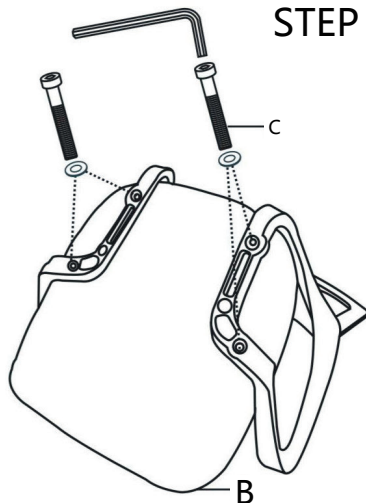
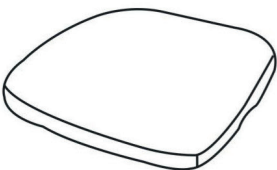

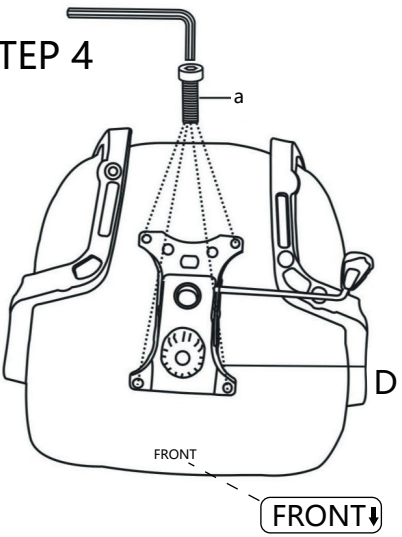
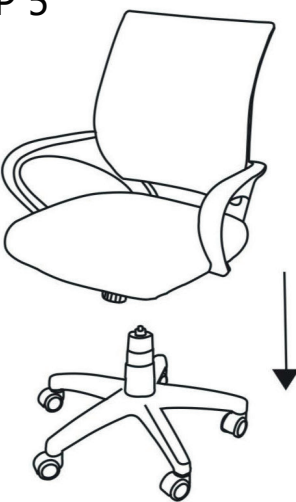



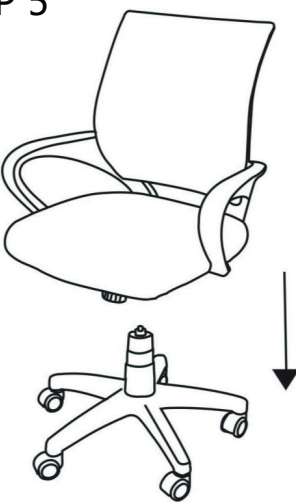

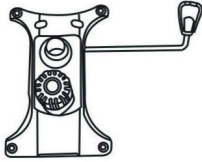

Assembly Instruction

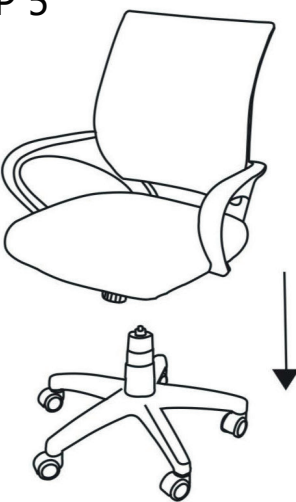
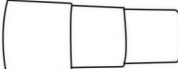
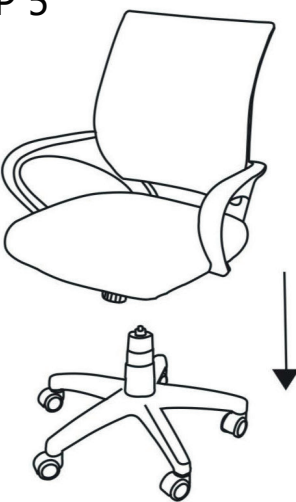
<p>A X1</p> 	<p>F X1</p> 	<p>STEP 1</p>  <p>Push the wheels to the base. Put the gas lift on the base. Then put the plastic cover.</p>	<p>STEP 2</p>  <p>Do not fasten the screws!</p>	<p>STEP 3</p>  <p>NOTE: Please assemble the armrests and backrest firstly.</p>
<p>B X1</p> 	<p>G X5</p> 	<p>STEP 4</p>  <p>FRONT FRONT↓</p> <p>Assemble the armrests and seat cushion. Assemble the seat cushion and backrest.</p>	<p>STEP 5</p> 	<p>STEP 6</p>  <p>Assemble the chair with two whole parts.</p>
<p>C X1</p> 	<p>H X1</p> <p>a  x4 M6X16MM</p>	<p>b  x4 M6X25MM</p>	<p>STEP 5</p> 	<p>STEP 6</p>  <p>Assemble the chair with two whole parts.</p>
<p>DX1</p> 	<p>c   x4 M6X30MM</p>	<p>I x1</p>  <p>M6</p>	<p>STEP 5</p> 	<p>STEP 6</p>  <p>Assemble the chair with two whole parts.</p>
<p>E X1</p> 	<p>J x1</p> 		<p>STEP 5</p> 	<p>STEP 6</p>  <p>Assemble the chair with two whole parts.</p>