

ASSEMBLY INSTRUCTIONS SIDEBOARD

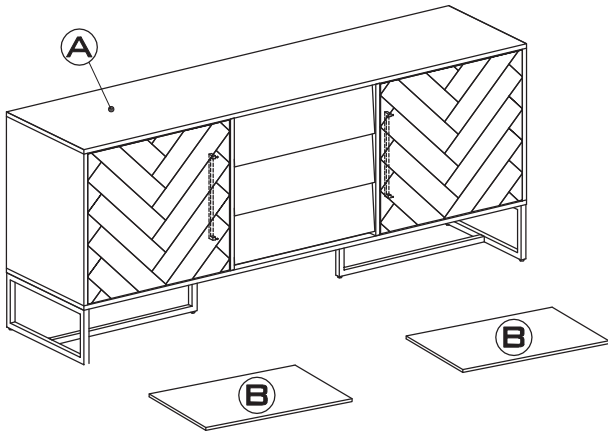

PARTS CHECK LIST

CODE	COMPONENTS	QTY
(A)	BODY	X01
(B)	SHELF	X02

HARDWARE CHECK LIST

CODE	DESCRIPTION	QTY
(D1)	SHELF PIN	X08

**PHILLIPS HEAD SCREWDRIVER TOOL NEEDED
(NOT INCLUDED)**

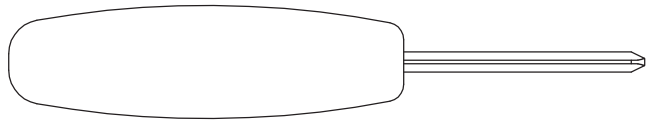

- PLEASE DO NOT DISCARD ANY OF THE PACKAGING UNTIL YOU HAVE CHECKED ALL THE PARTS AND THE PACKS OF HARDWARE.
- BEFORE YOU BEGIN TO ASSEMBLE YOUR NEW PIECE OF FURNITURE, PLEASE CHECK TO ENSURE THAT ALL PARTS HAVE BEEN SUPPLIED.
- FOLLOW INSTRUCTIONS CLOSELY AS DEVIATION FROM THEM MAY VOID YOUR WARRANTY AND PRESENT A POSSIBLE SAFETY RISK.
- IT IS RECOMMENDED THAT ASSEMBLY IS DONE ON A SOFT SURFACE LIKE CARPET TO AVOID ANY DAMAGE.
- PERIODICALLY CHECK AND RE-TIGHTEN ANY FASTENERS. WIPE DOWN ALL SURFACES WEEKLY WITH A CLEAN CLOTH. DO NOT CLEAN ANY SURFACES WITH HARSH ABRASIVES OR CHEMICALS.

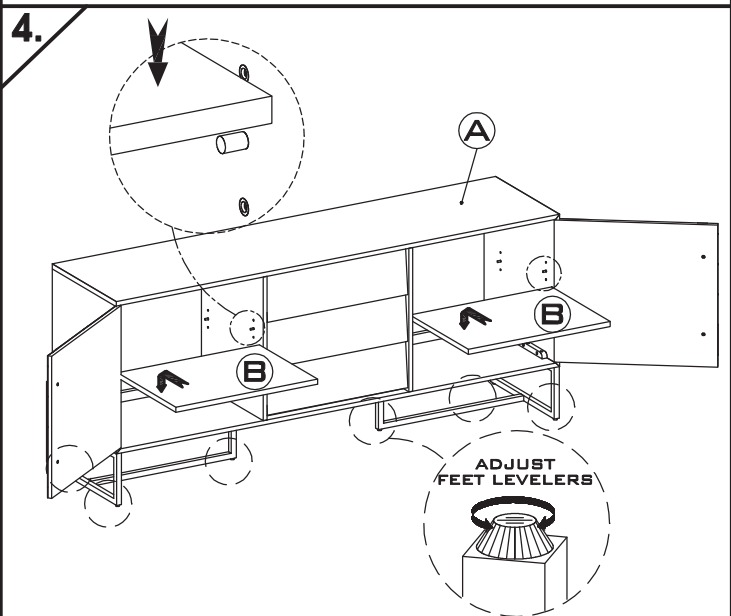
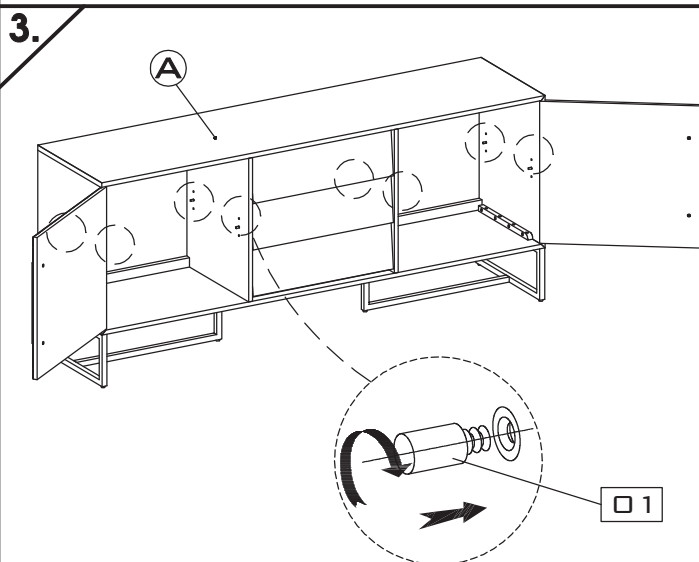
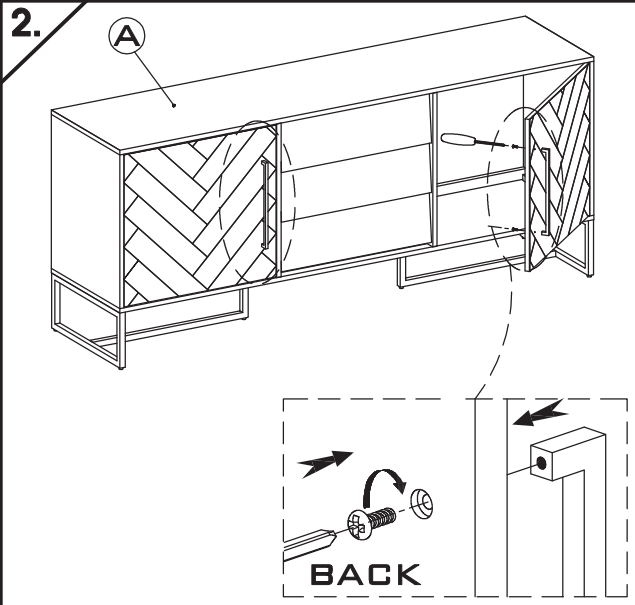
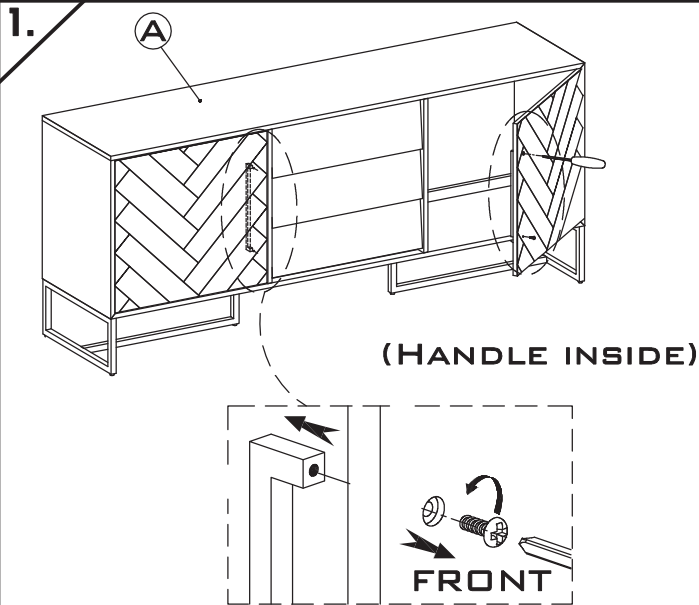

FURNITURE TIPPING RESTRAINT FOR SIDEBOARD

Young children may be injured by tipping furniture and the use of a tipping restraint is highly recommended.

When properly installed, this restraint could provide protection against the unexpected tipping of furniture due to small tremors, bumps or climbing. We recommend mounting this restraint to a wall stud.

WARNING: This product is only a deterrent. It is not a substitute for proper adult supervision.

TIPPING KIT CHECK LIST

CODE	COMPONENT	QTY
01	PLASTIC STRAP	2
02	SCREW	4
03	NYLON WALL PLUG	2
04	METAL BRACKET	4

Installation Instruction:

1. Attach one of the mounting brackets securely near the top back edge of the furniture piece by inserting the screw. Refer to picture A.
2. Determine the final position of the furniture piece. Mark location on the wall approximately 2" below the bracket mounted to the back of the furniture.
3. Drill a starter hole into the wall stud. If wall stud is not available, drill a hole into the wall and insert plastic anchor. Gently tap anchor until the flange of the anchor is flush with the wall.
4. Attach the second bracket by inserting and securing the screw to the wall. Refer to picture B.
5. Align the two brackets.
6. Thread the strap through both brackets and tighten until snug.
7. Check to make sure that the brackets are firmly installed the strap is secure.

