

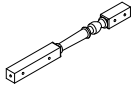

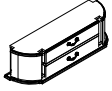



ASSEMBLY INSTRUCTION

ITEM NO: FSH2533 CONSOLE TABLE

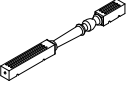
Thank you for purchasing this quality product. Be sure to check all packing material carefully for small parts which may have come loose inside the carton during shipment. Separate, identify and count all parts and metal hardware. Compare with parts list to be sure all parts are present. If any part(s) are missing or damaged, please contact your local furniture dealer. For efficient and speedy service, please indicate the model number and code letter of part(s) needed.

*** Do not fully tighten bolts until fully assembled ***

No.	COMPONENT LIST	Q'ty	No.	COMPONENT LIST	Q'ty
A	 TABLE TOP	1pc	D	 FRONT LEGS	2pcs
B	 TABLE BOTTOM	1pc	E	 STAND LEGS	4pcs
C	 BACK LEGS	2pcs			
No.	HARDWARE LIST	Q'ty	No.	HARDWARE LIST	Q'ty
1	 Bolts 5/16x1.6"	16pcs	3	 Flat Washer 5/16	16pcs
2	 Lock Washer 5/16	16pcs	4	 Allen key K4	1pc

Step 1: Pull out Drawer and Assembly part (C),(D) to(A). Then use Bolts (1), Lock washers (2), Flat washers (3). Do not fully tighten.

Step 2: Pull out Drawer and Assembly part (C),(D) to(B). Then use Bolts (1), Lock washers (2), Flat washers (3). Use Allen key (4) fully tighten all Bolts.

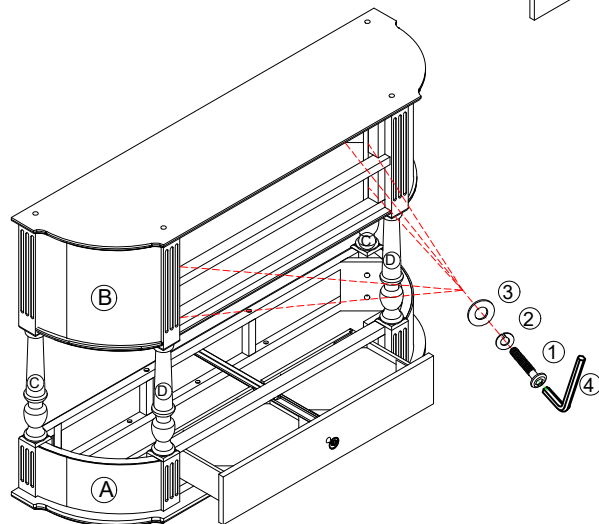
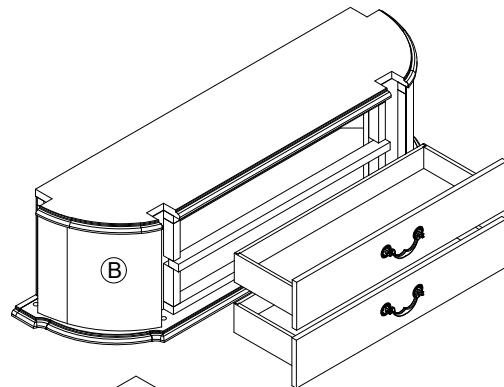
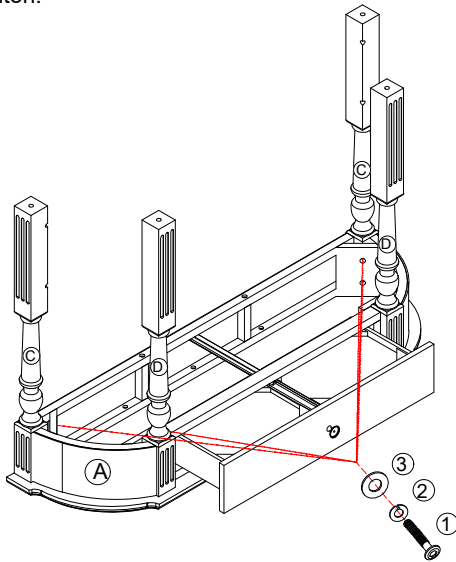

ASSEMBLY INSTRUCTION

ITEM NO: FSH2533 CONSOLE TABLE

Thank you for purchasing this quality product. Be sure to check all packing material carefully for small parts which may have come loose inside the carton during shipment. Separate, identify and count all parts and metal hardware. Compare with parts list to be sure all parts are present. If any part(s) are missing or damaged, please contact your local furniture dealer. For efficient and speedy service, please indicate the model number and code letter of part(s) needed.

***** Do not fully tighten bolts until fully assembled *****

Step 3: Align and place part (E) to (C),(D) . Rotate clockwise fully tighten.

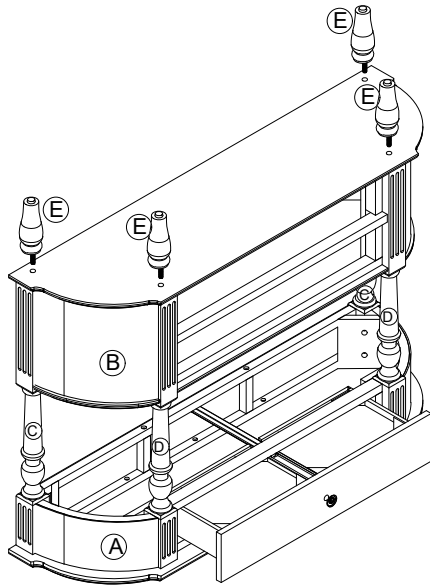

Step 4: Assembly drawers to body.

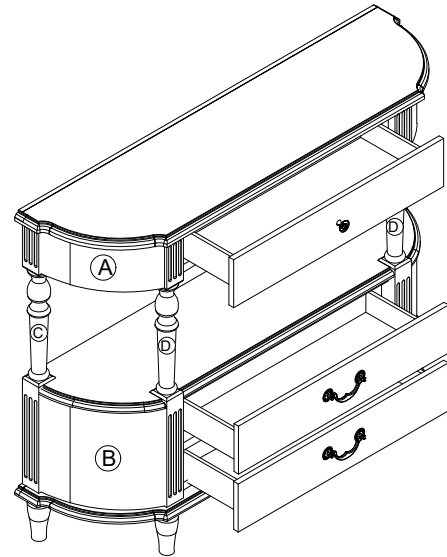

FINISH .
THANK YOU !