

# Montageanleitung Assembly instructions Instructions de montage Instrucciones de montaje Istruzioni per il montaggio Инструкция для монтажа Instrukcja montażu Montážní návod Návod na montáž Szerelési utasítás Инструкция за монтаж Kurulum Talimatları Navodilo za montažo Montagehandleiding A s e n n u s o h j e Upute o montaži

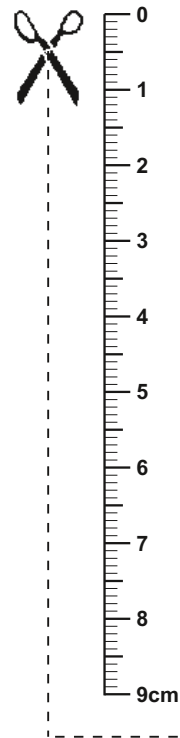

Beschläge / fittings / Ferrures pour meubles / Herrajes / Guarnizioni / Железные оправы для мебели / Okucia / Kování / Kovanie / Vasalások / обков / Parçaları / okovje / Hang- en sluitwerk / helat / Obloge

4 x GL1	6 x SP10	4 x ZB 4	4 x SP3
2 x VB5	17x VB1	17 x VB14	2 x TB8
2 x SK4	4 x SO1	2 x SG1	1 x ZB1
18 x VB4	2 x GL7	2 x SP11	4 x AK1
8 x BT1	2 x TB19	4 x SP1	18 x AK2
2 x GR18	4 x SR1	1 x WI3	
4 x RO30	4 x SR 4	1 x WI8	15 x AK3
	1 x SP7	2 x SO14	

Sie benötigen:  
 You need:  
 Vous avez besoin de:  
 Necesita:  
 Le servono:  
 Вам нужно:  
 Potrebujete:  
 Tarvitset:

Potrzebne są:  
 Potřebujete:  
 Potrebujete:  
 Szükséges eszközök:  
 На Вас са Ви нужны:  
 Ihtiyaciniz:  
 U hebt nodig:  
 Trebate:

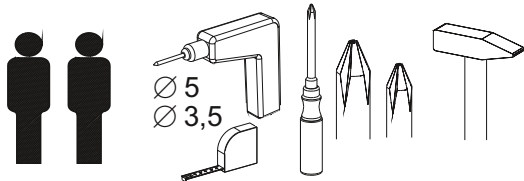

**A**

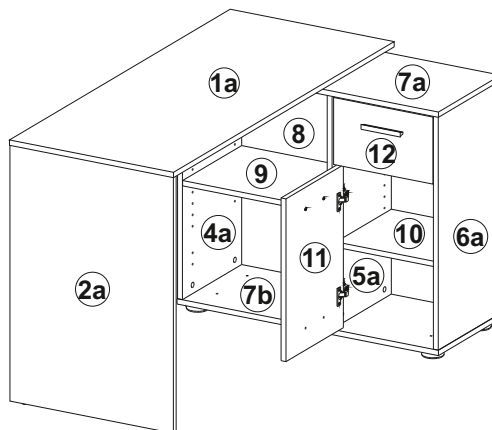

**B**

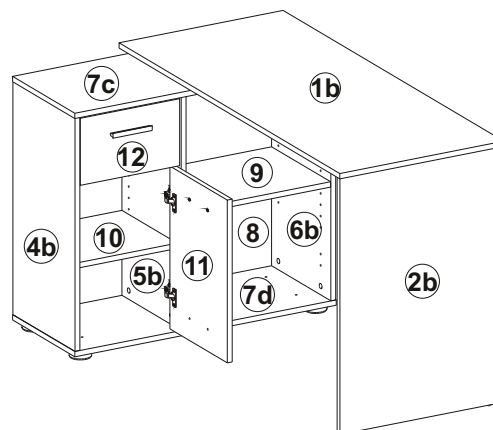

**C**

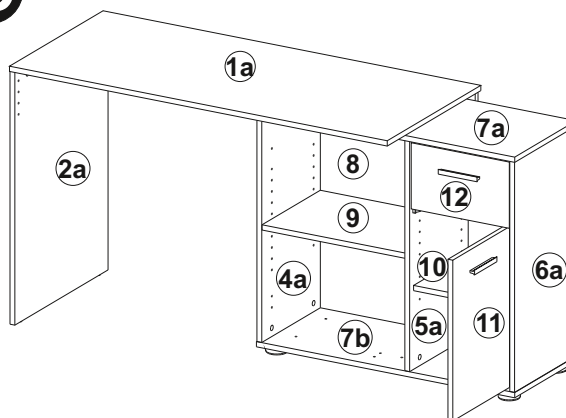

**D**

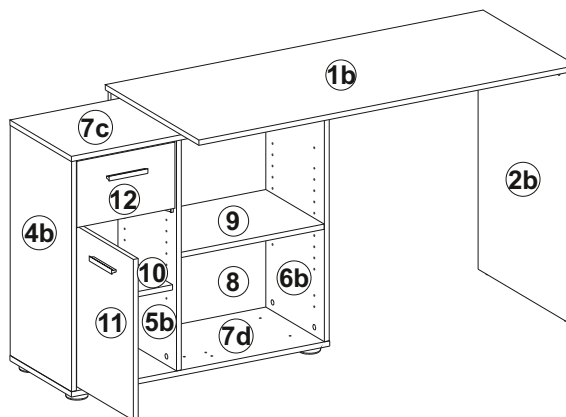



- DE** Bitte die Montageanleitung vor Beginn sorgfältig studieren. Um eine ordnungsgemäße und mangelfreie Erstellung zu gewährleisten muss die Montage exakt in der gezeigten Reihenfolge ausgeführt werden. Wir empfehlen die Montage nur durch fachkundiges Personal.
- GB** Please carefully read through the assembly instructions before starting. To ensure proper, fault-free construction, assembly is to be carried out exactly as shown in the sequence. We recommend having the assembly done only by qualified personnel.
- FR** Lire scrupuleusement les instructions de montage avant de commencer le montage. Afin de garantir une construction conforme et irréprochable, le montage doit être effectué exactement dans l'ordre indiqué. Nous recommandons de ne faire effectuer le montage que par du personnel qualifié.

- ES** Antes de empezar lea detenidamente las instrucciones de montaje. Para garantizar una construcción adecuada y sin defectos, el montaje deberá llevarse a cabo en el orden exacto que se indica. Le recomendamos que el montaje lo efectúe únicamente personal especializado.
- CZ** Prostudujte, prosím, před začátkem práce pečlivě Montážní návod. Aby bylo zaručeno žádné a bezchybné sestavení, musí se montáž provést přesně v uvedeném pořadí. Doporučujeme, aby montáž prováděl vždy jen odborník.
- SK** Pred započatím práce si prosíme starostlivo prečítajte návod na montáž. Aby bolo možné zaručiť správne a bezchybné zostavenie, je nutné pri montáži dodržať presne vyznačený postup. Odporúčame nechať urobiť montáž odborníkovi.
- HU** Kezddés elttartásán tanulmányozza a szerelési utasítást! Aszabályszerés hibátlan elkészítésének garantálása érdekében a szerelést pontosan amutatott sorrendben kell elvégezni. Javasoljuk, hogy csak szakképzett személyzet végezze el a szerelést.
- PL** Przed rozpoczęciem montażu proszę uważnie zapoznać się ze stosowną instrukcją. Aby zapewnić prawidłowe przeprowadzenie montażu należy wykonywać wszystkie czynności dokładnie wg przedstawionej kolejności. Polecamy montaż wyłącznie przez fachowy personel.
- RU** Перед началом внимательно изучите инструкцию по монтажу, чтобы гарантировать надлежащую и безошибочную компоновку, монтаж должен выполняться точно в показанной последовательности. Мы рекомендуем монтаж только силами компетентного персонала.
- SI** Pred začetkom, prosimo, navodilo za montažo skrbno tudirajte. Za zagotovitev redne in nepomanjkljive izdelave se mora montaža izvesti natančno v prikazanem vrstnem redu.
- IT** Per favore prima dell'inizio studiare accuratamente le istruzioni per il montaggio. Per garantire una realizzazione senza errori, il montaggio deve essere fatto rispettando esattamente la sequenza indicata. Consigliamo di far eseguire il montaggio esclusivamente da parte di personale esperto.
- BG** Преди монтажа внимателно разучете инструкцията. Монтажът задължително трябва да се извърши в посочената последователност, за да отговаря на изискванията и да бъде безупречен. Не препоръчваме монтажа да се извършва от квалифициран персонал.
- TR** Lütfen kurulum talimatları başlamadan önce dikkatle iyice inceleyiniz. Do ru ve hatasız üretim sağlamak için, montajı gösterilen sırada tam olarak yapılmalıdır. Biz montajı sadece e itimli personel tarafından öneririz.
- HR** Molimo Vas da upute omontaži prije po etka pažljivo pročitate. Kako bi se zajamila pravilna i besprijekorna izrada, montaža se mora izvesti točno po prikazanom redoslijedu. Preporučujemo montaż samo od strane stručnog osoblja.
- NL/BE** Bestudeer de montagehandleiding a.u.b. zorgvuldig alvorens te beginnen. Omeen volledig correcte en vlekkeloze opstelling te garanderen, moet demontage precies in de getoonde volgorde worden uitgevoerd. Wij raden aanomde montage alleen door vak-kundig personeel te laten uitvoeren.
- RO** Înainte de a începe, citiți cu atenție instrucțiunile de montaj. Pentru a se asigura un montaj corect și fără defecte, acesta trebuie realizat exact în ordinea indicată. Recomandăm ca montajul să fie făcut de personal calificat.
- DK** Husk at læse monteringsvejledningen grundigt, inden du begynder. Arbejdsstrinnene skal udføres i den viste rækkefølge for at sikre, at resultatet bliver helt rigtigt. Vi anbefaler, at du lader monteringsarbejdet udføres af en fagmand.
- PT** Estudar as instruções de montagem antes do início. Para garantir uma constituição correcta e sem falhas, a montagem tem que ser efectuada exactamente na sequência indicada. Recomendamos que a montagem seja efectuada apenas por pessoal técnico especializado.
- SE** Studera monteringsanvisningen noga innan du börjar att montera. För att garantera ett korrekt och felfritt uppförande, måste monteringen ske exakt och i den anvisade ordningsföljden. Vi rekommenderar att endast låta sakkunnig personal utföra monteringen.



- DE** Entsorgen Sie die Verpackungen bzw. das Produkt nach Abnutzung Umweltgerecht.
- GB** Please dispose of the packaging and of an old product no longer in use without any danger to the environment.
- FR** Veuillez vous débarrasser de l'emballage ou du produit après son utilisation selon les conditions Sur l'environnement.
- ES** Desechar por favor el embalaje o producto ateniéndose a las normas ecológicas vigentes na vez que éste se haya desgastado.
- CZ** Po použití likvidujte obal nebo výrobek ekologicky.
- SK** Obal resp. produkt po opotrebení zlikvidujte ekologicky.

- HU** Kérjük, hogy a csomagolást, illetve a terméket elhasználódás után környezetkímélő módon takarítsa el.
- PL** Produkt po zuyciu i jego opakowanie utylizować w ekologicznie właściwy sposób.
- RU** У паковку и изделие после амортизации утилизируйте в соответствии с экологическими требованиями.
- SI** Poskrbite za okolju prijazno odstranitev embalaže oz. produkta po uporabi.

- IT** Non disperdere nell'ambiente e provvedere ad uno smaltimento ecologico dopo l'uso.
- BG** И зхвърляйте опаковката респ. вече негодния продукт според изискванията за опаковка на околната среда.
- TR** Ambalaj ve ürünü kullanımdan sonra çevreye zarar vermeden yok edin.
- HR** Odstranite pakovanje odnosno proizvod nakon upotrebe ekološki.
- NL/BE** Voer de verpakking resp. het product na gebruik op milieuvriendelijke wijze af.
- RO** Elimina i ambalajul, respectiv produsul după ce s-a uzat, fără a afecta mediul înconjurător.
- DK** Forpackningsaffald respektive produktet skal fjernes miljørigtigt.
- PT** Elimine a embalagem ou o produto observando as normas ecológicas vigentes depois do seu desgaste.
- SE** Avfall från förpackning respektive produktet skall utföras miljökorrekt.

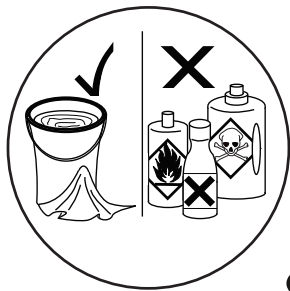

- DE** Pflegehinweis! Bitte nur mit einem Staubtuch oder einem feuchten Lappen reinigen. Keine scheuernden Mittel, Säure, Lösungsmittel, Spiritus, Azeton etc. verwenden. Vor Montage von Hochglanzfronten die Schutzfolie entfernen.
- GB** Care instructions! Please do only clean with a duster or a damp cloth. Do not use abrasive Cleaning agents, acids, solvents, methylated spirits, or acetone etc.! Remove the protective foil before inserting the high-gloss front panels.
- FR** Indications d'entretien ! Ne nettoyer qu'avec un chiffon à poussière ou un chiffon humide. Ne pas utiliser de produits agressifs ni d'acides, de solvants, d'alcool, d'acétone, etc. Retirer le film protecteur avant le montage des façades brillantes.
- ES** Indicaciones de mantenimiento! Limpiar sólo con un trapo para el polvo o con un trapo húmedo. No deben utilizarse medios abrasivos, ácido, disolventes, alcohol, acetona, etc. Antes del montaje de frentes de alto brillo, retirar la lámina de protección.

- CZ** Pokyny pro ošetření! Iste te, prosím, pouze prachovkou nebo vlhkým hadrem. Ním mýdlovým roztokem nepoužívejte žádné abrazivní čisticí prostředky, kyseliny, ředidla, lih, aceton atd. Před montáží čel s vysokým leskem odstraňte ochrannou fólii.
- SK** Pokyn k údržbe! Prosíme utiera len prachovkou alebo vlhkou handrikou. Ným mydlovým roztokom, nepožívajte žiadne agresívne prostriedky, kyseliny, riedidlá, lieh, aceton a pod. Pred montážou odstráňte ochrannú fóliu z vysokolesklých čiel.
- HU** Ápolási útmutatás! Kérjük, hogycsak portörrel kendővel vagy nedves ronggyal tisztítsa! Os szappanos vízzel tisztítsa. Ne használjon súrolószereket, savakat, oldószereket, alkoholt, acetont, stb. A magas fényezésű frontelemek beszerelése előtt a védőfóliát el kell távolítani.
- PL** Pielęgnacja! Czyść tylko przy pomocy suchej lub wilgotnej ściereczki. Nie wolno stosować jakichkolwiek środków ściernych, kwasów, rozpuszczalników, spirytusu, acetonu itp.! Przed montażem frontów na wysoki połysk należy zdjąć folię ochronną.
- RU** Указание по уходу! росьба чистить только тряпкой для пыли или влажной тряпкой. ни в коем случае не применять абразивные чистящие средства, кислоту, растворители, спирт, ацетон и т.п. Перед установкой снять защитную пленку с лицевых полированных сторон.
- SI** Navodilo za nego! Iste te, prosimo, le s krpo za prah ali z vlažno krpo. Ne uporabljajte sredstev za drgnjenje, kisline, topil, pirita, acetona itd. Pred namestitvijo visoko-sijajne prednje strani odstranite zaščitno folijo.
- IT** Istruzione di cura! Per favore pulire solo con un panno per rimuovere polvere o con uno straccio umido. Non utilizzare prodotti abrasivi, acidi, soluzioni, spirito, acetone, ecc.! Prima del montaggio, rimuovere la pellicola protettiva dalle parti anteriori ad alta lucentezza.
- BG** Указание за поддръжка! Очиствайте само с кърпа за прах или влажен парцал. не използвайте абразивни препарати, киселина, разтворител, спирт, ацетон и т.н.! Преди монтаж на фасади с огледален блясък отстранете защитното фолио.
- TR** Bakım talimatları! Lütfen sadece bir toz bezli ya da nemli bir bezle temizleyiniz. Aşındırıcı maddeler, asitler, çözücüler, alkol, aseton vb kullanmayın! Montajdan önce yüksek parlak cephelerden koruyucu folyoyu çıkarın.
- HR** Uputa o njegovanju! Istiti samo jednom maramom za prašinu ili jednom vlažnom krpom. Ne koristite abrazivna sredstva, kiseline, otapala, benzin, aceton i slično. Prije montaže otklonite zaštitnu foliju od visoko sjajne prednje strane.
- NL/BE** Onderhoudsinformatie! A.u.b. alleen reinigen met een stofdoek of een vochtige lap. Geen schurende reinigingsmiddelen, zuren, oplosmiddelen, alcohol, aceton, etc. gebruiken! Voor montage van hoogglansfronten de beschermfolie verwijderen.
- RO** Indicație privind întreținerea! Rugăm să curățați doar cu o cârpă uscată sau cu o lavetă umedă. Nu utilizați agenți abrazivi, acizi, solvenți, spirit, aceton etc. Înainte de montarea fronturilor foarte lucioase, îndepărtați folia de protecție.
- DK** Pleje! Rengøring foretages med en støvklud eller en fugtig klud. Brug ingen skurende midler, syre, opløsningsmidler, spiritus, azeton etc. Fjern beskyttelsesfolien inden montering af højglansfronter.
- PT** Indicação de tratamento! Limpar apenas com um pano suave ou humedecido. Não usar produtos abrasivos, ácidos, solventes, álcool etílico, acetona, etc. Antes da montagem das frentes de brilho intenso remover a película de proteção.
- SE** Skötselavvisning! Rengör antingen med en torr dammtrasa eller med en fuktig trasa. Inga skurmedel, syror, sprit, lösningsmedel, aceton osv. får användas. Avlägsna skyddsfilmen från höglansfronterna före montering.

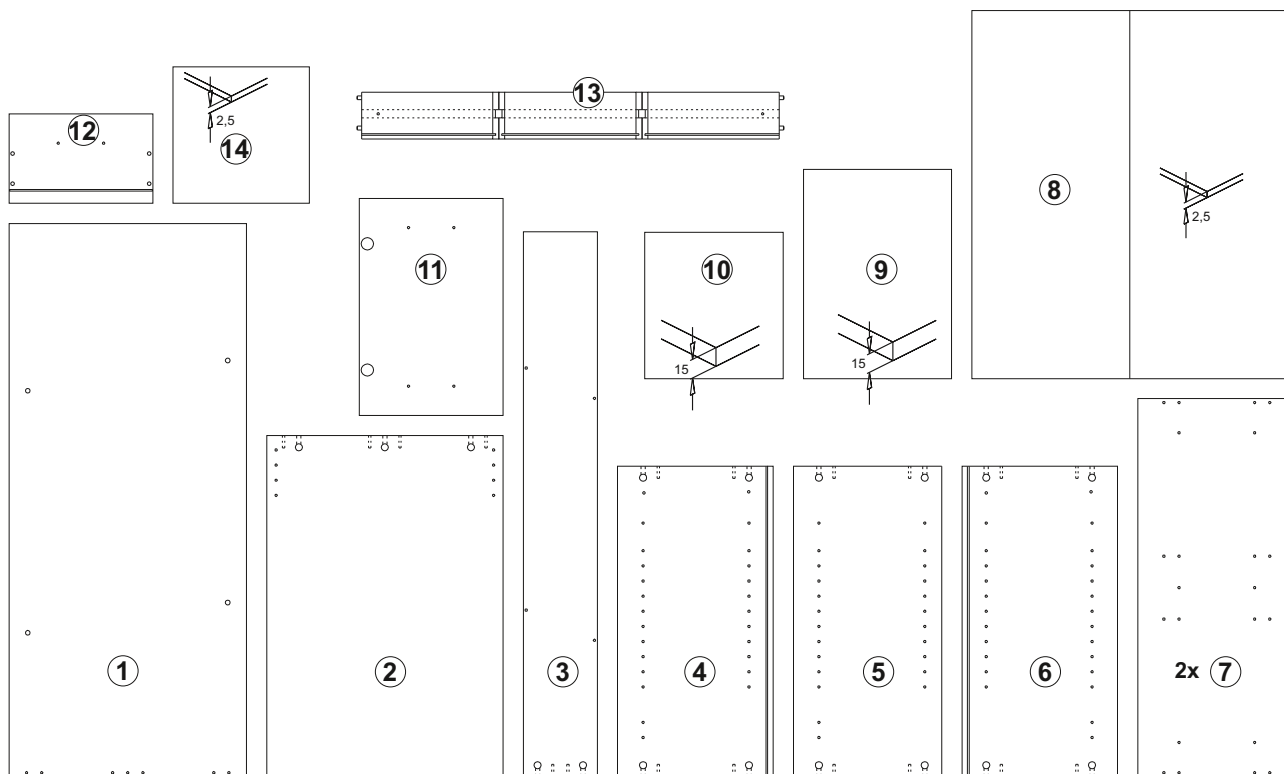

**A**

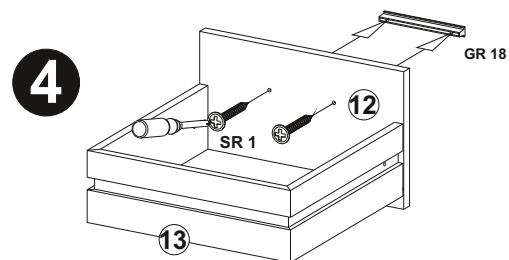
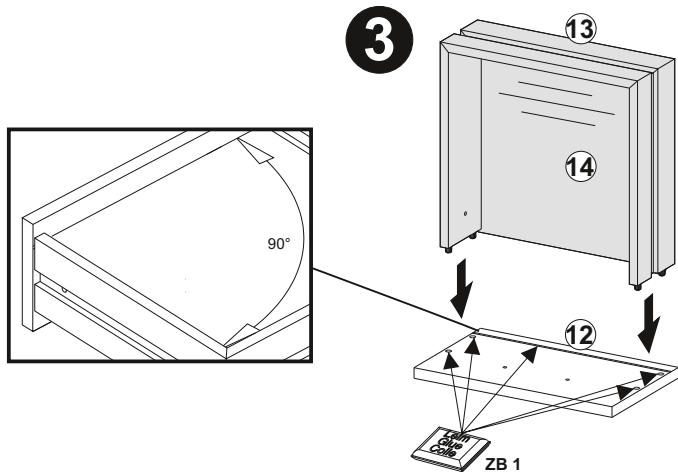
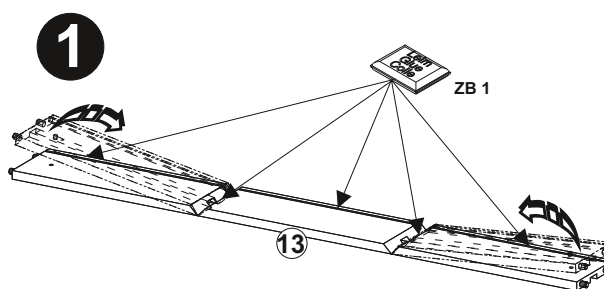
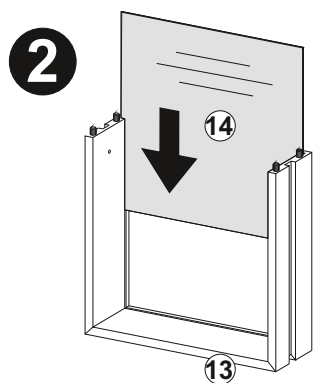
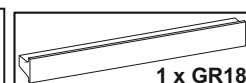
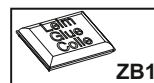

# B

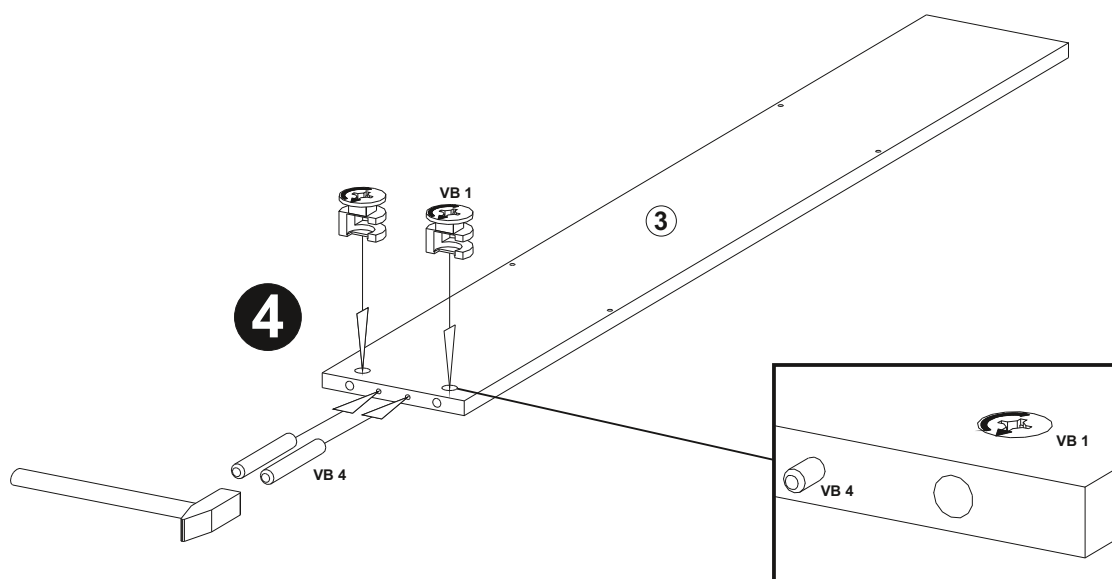
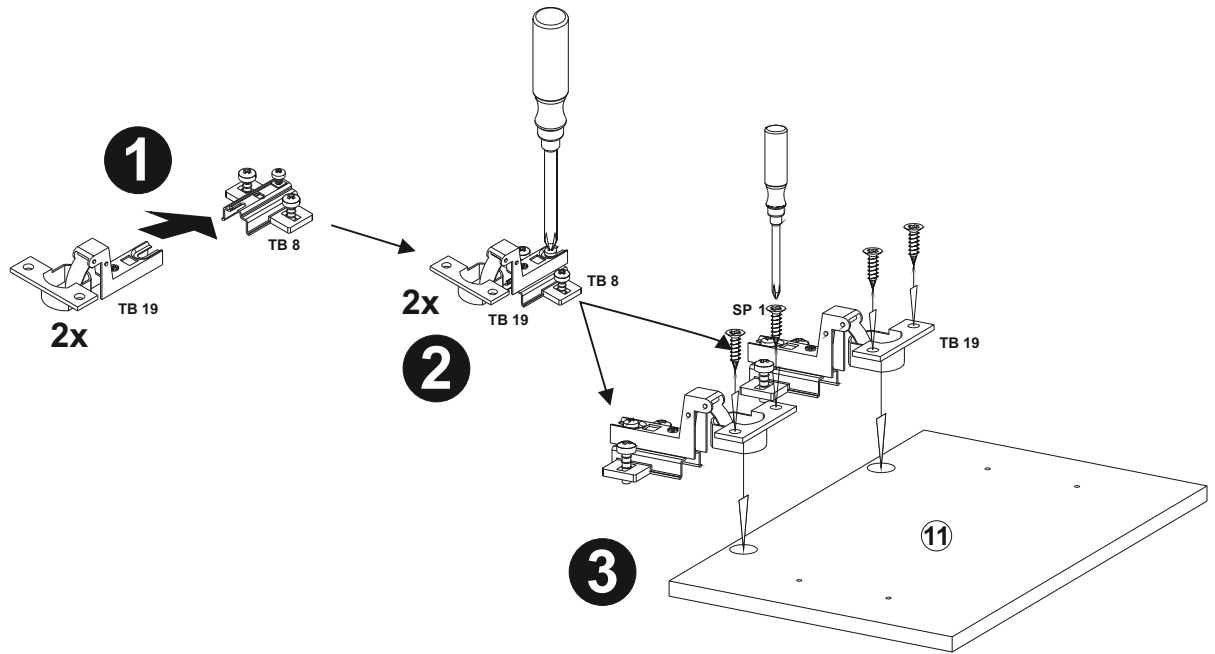
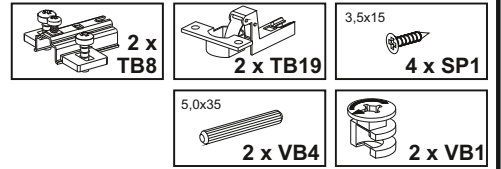

# C1

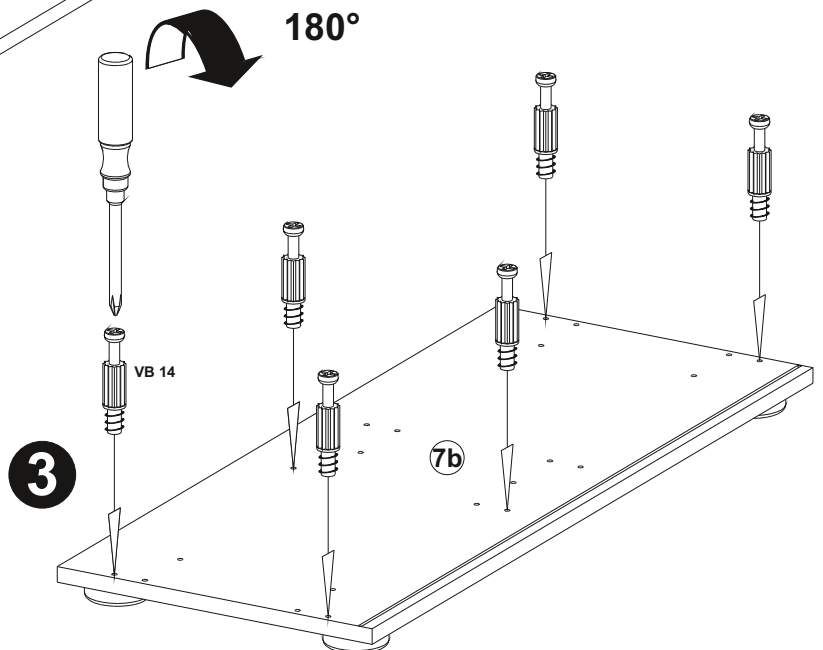
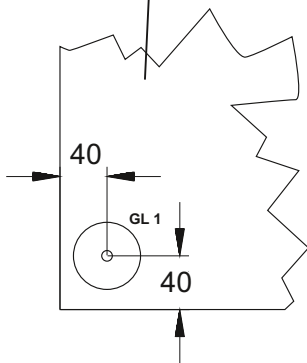
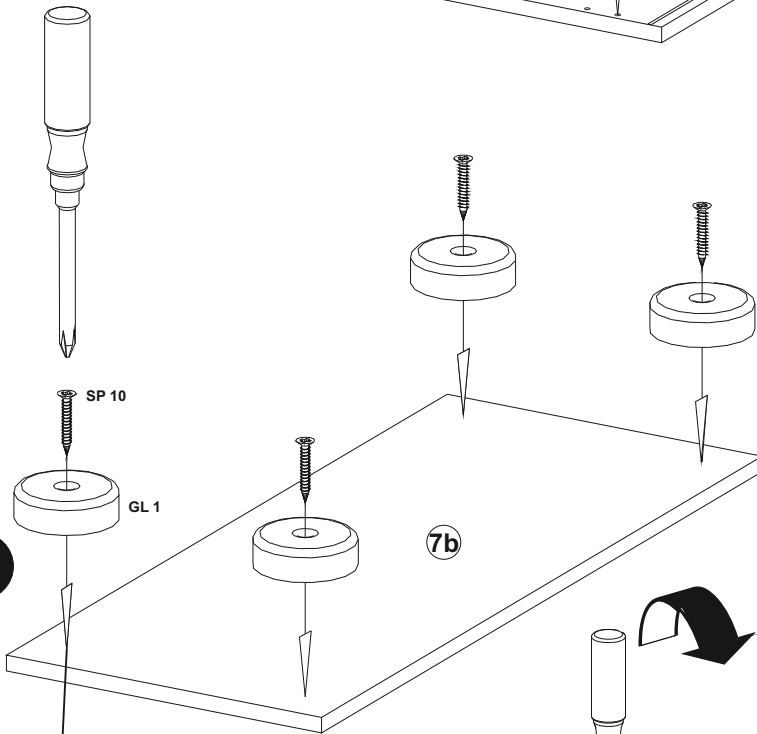
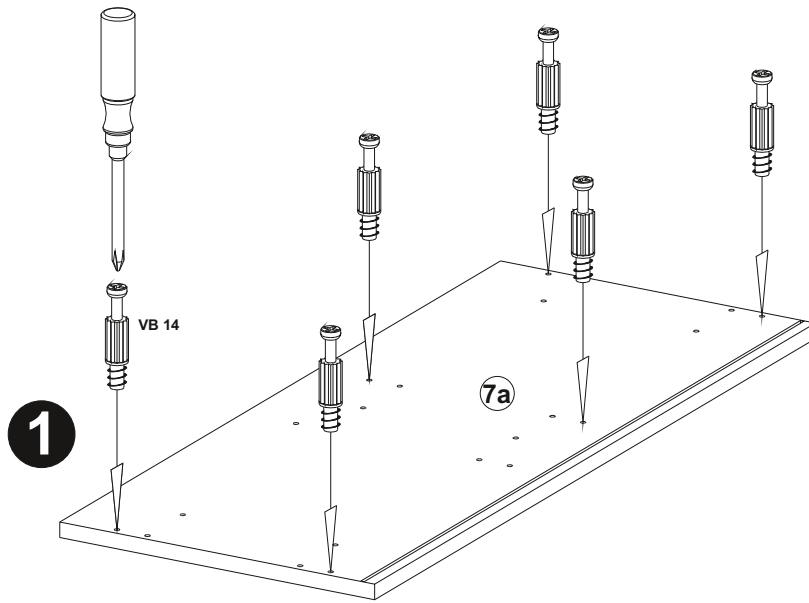
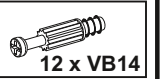
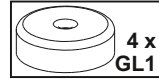
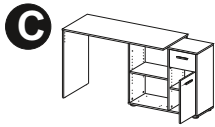
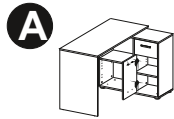

# C2

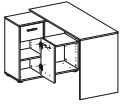
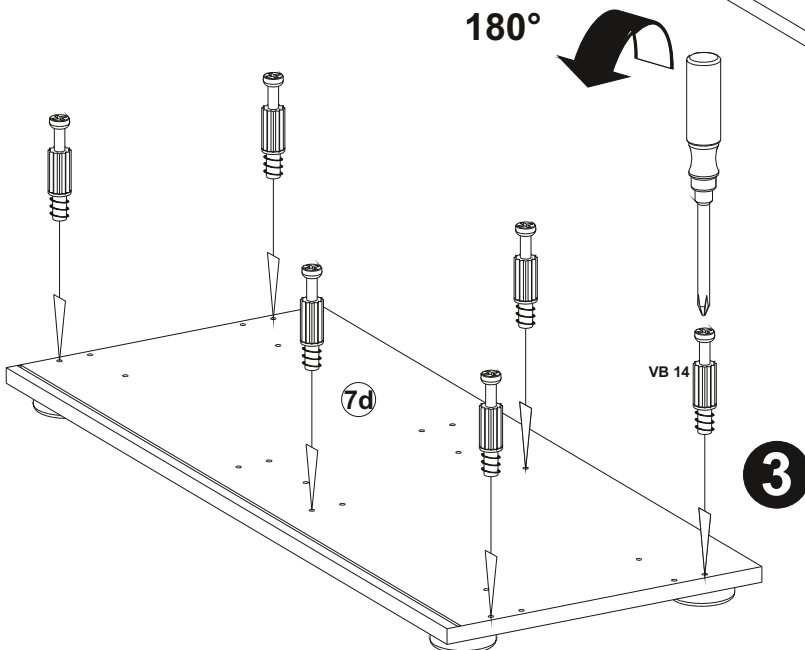
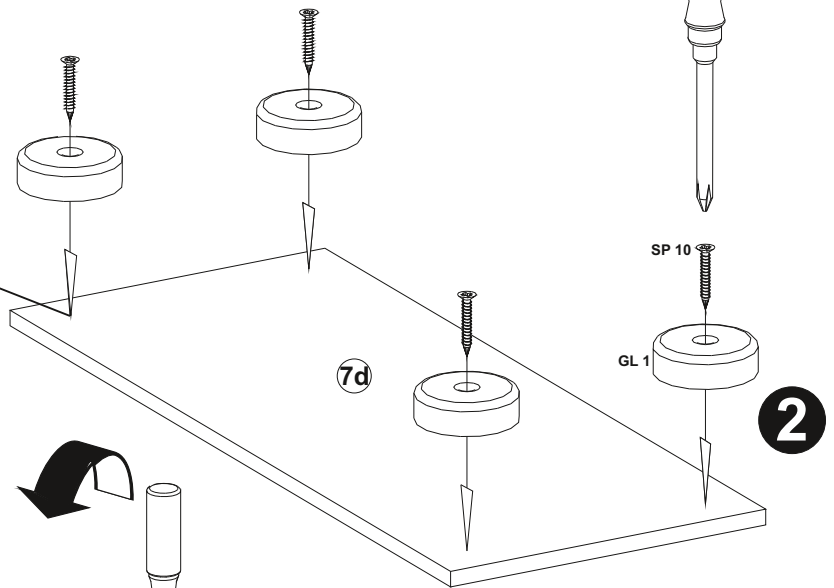
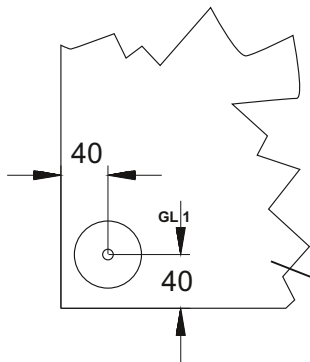
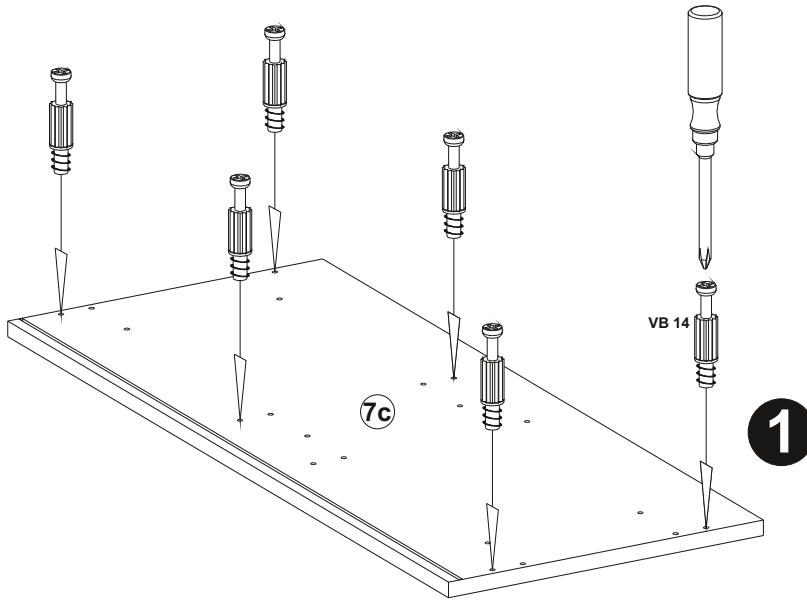
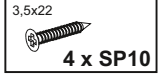
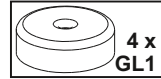
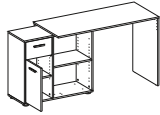
**B****D**

# D1

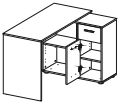
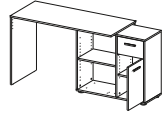
**A****C**

8 x BT1



6,2x10,5  
4 x SO1



280  
2 x SK4



5,0x35  
12 x VB4

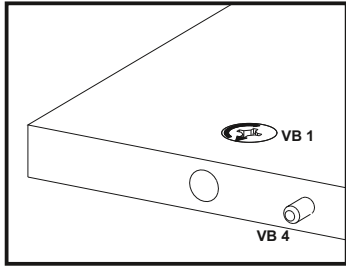
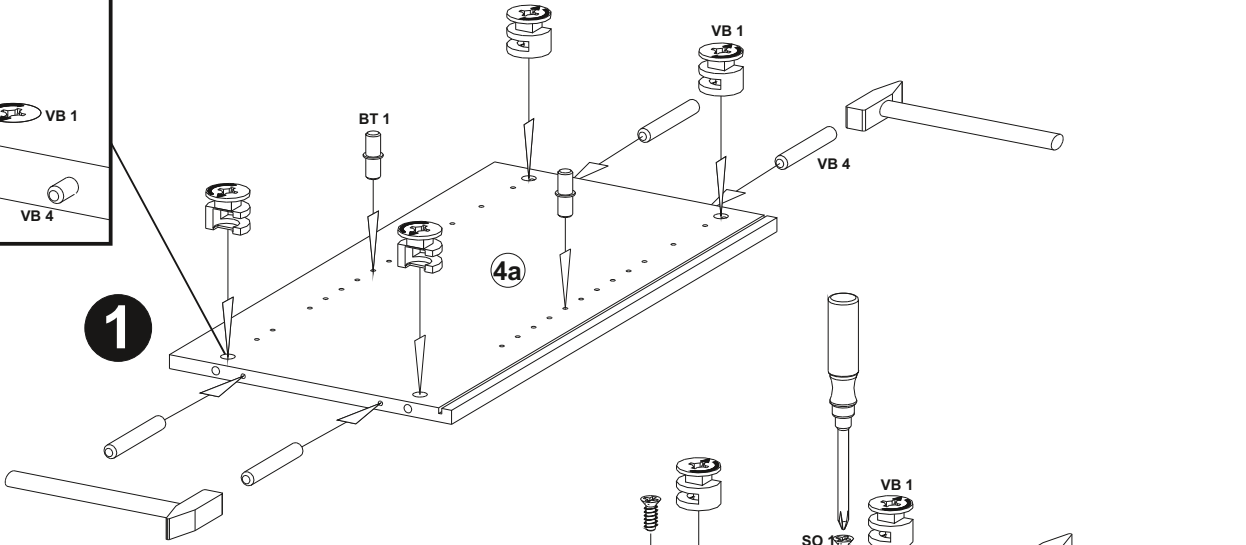
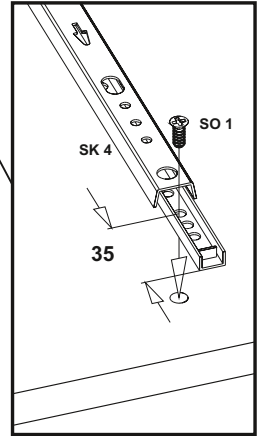
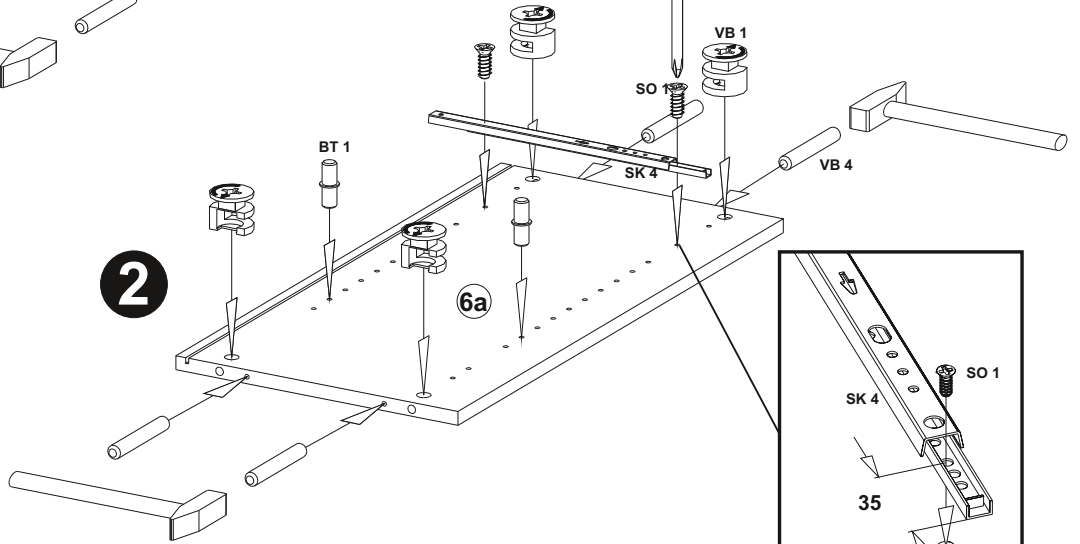
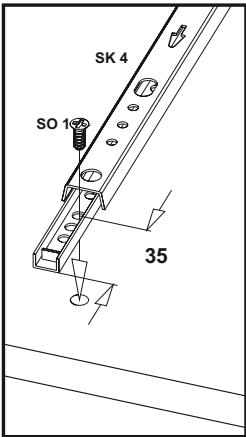
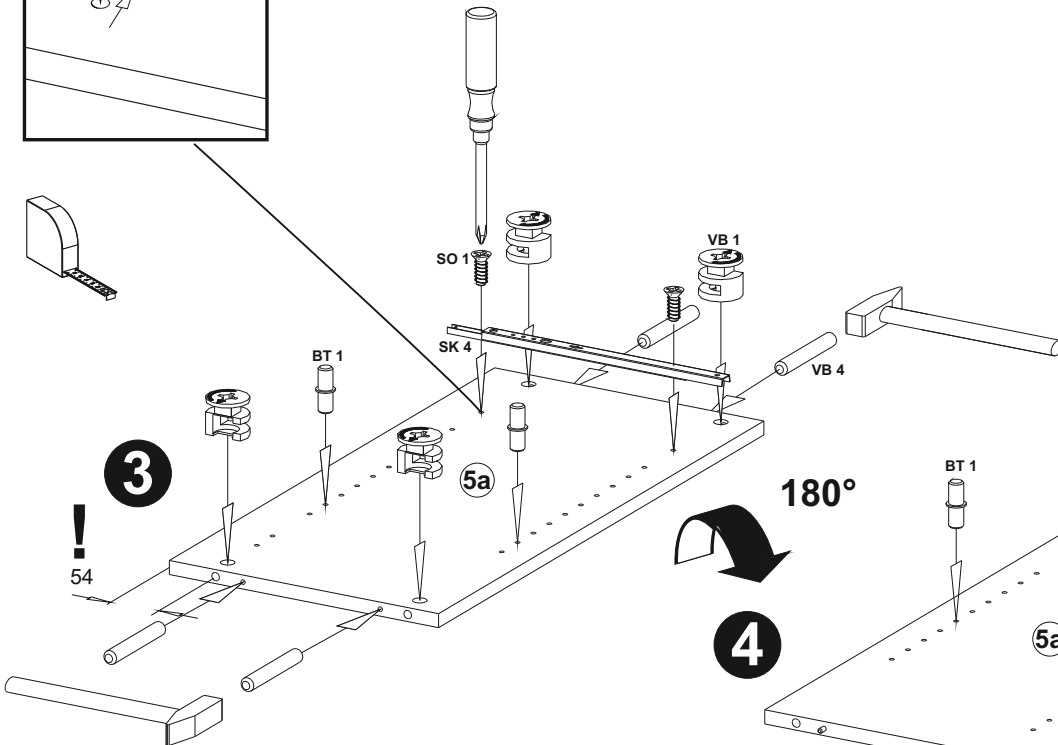
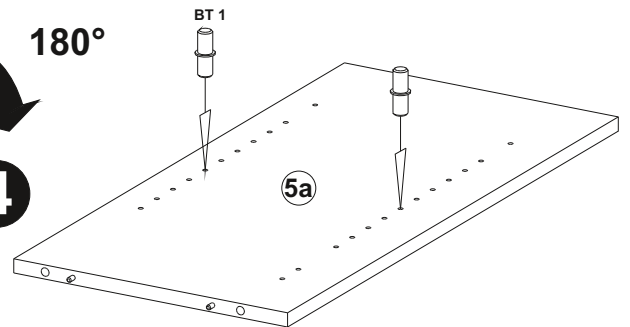

12 x VB1

**1****2****3****!**  
54**180°****4**

# D2

**B**

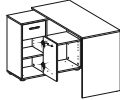

**D**

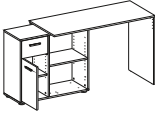

6,2x10,5  
**4 x SO1**



280  
**2 x SK4**



5,0x35  
**12 x VB4**



**12 x VB1**



**8 x BT1**

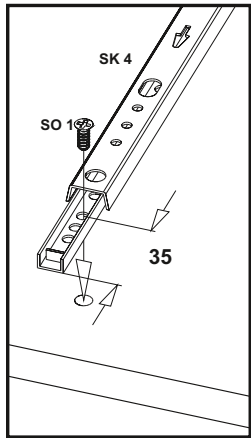

**1**

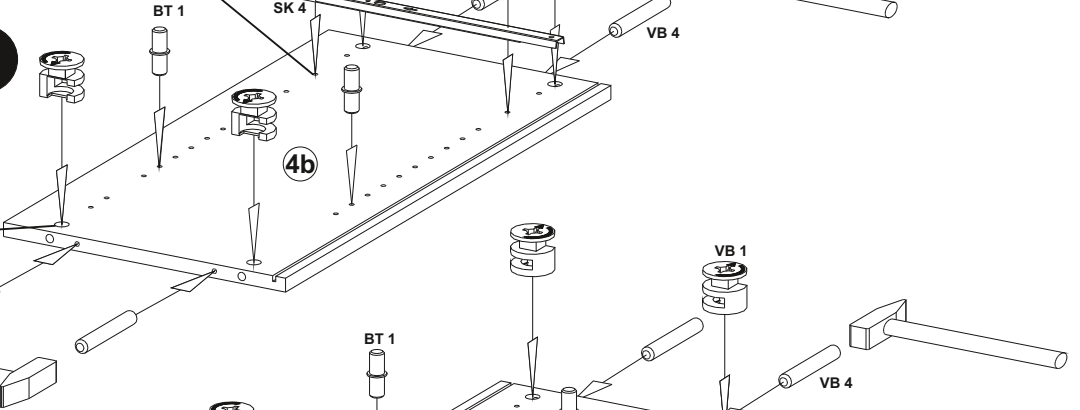

**2**

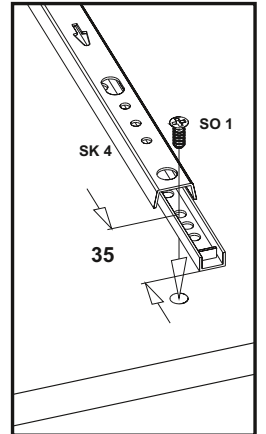
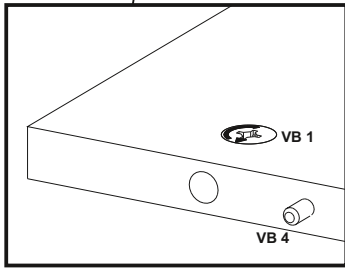
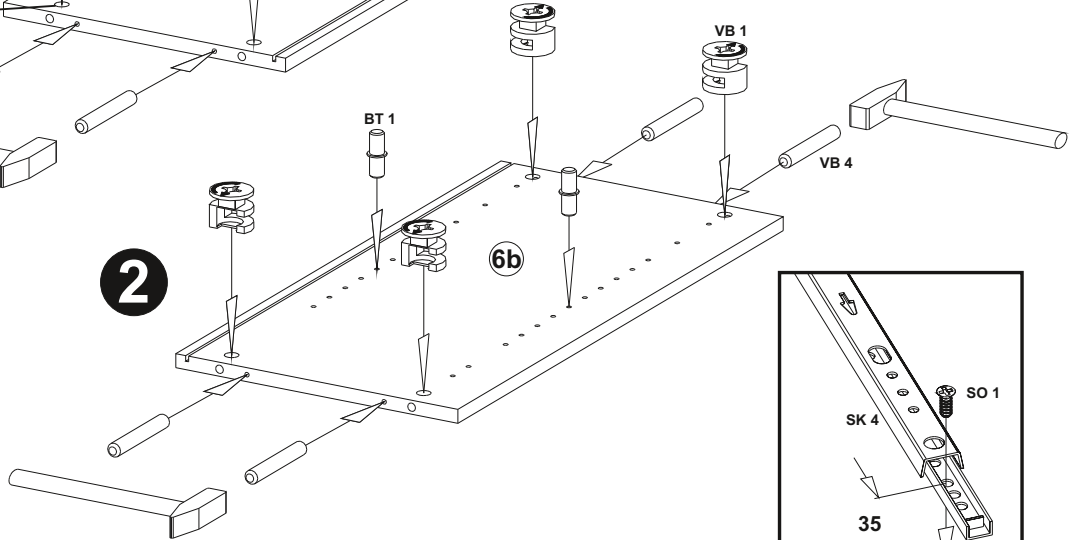

**3**

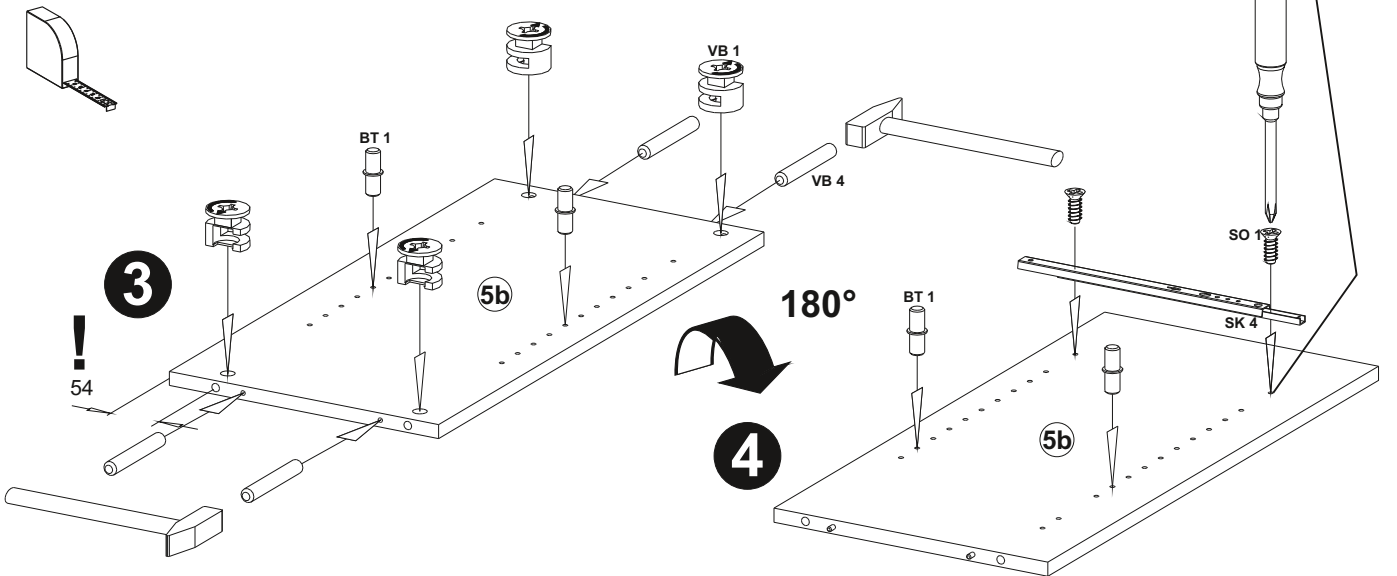

**4**

# E1

**A**

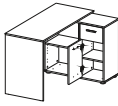

**C**

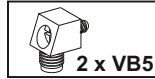
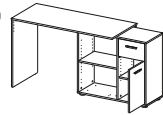

2 x VB5



2 x GL7

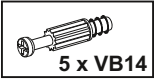

5 x VB14

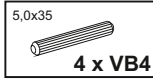

5,0x35

4 x VB4



3 x VB1

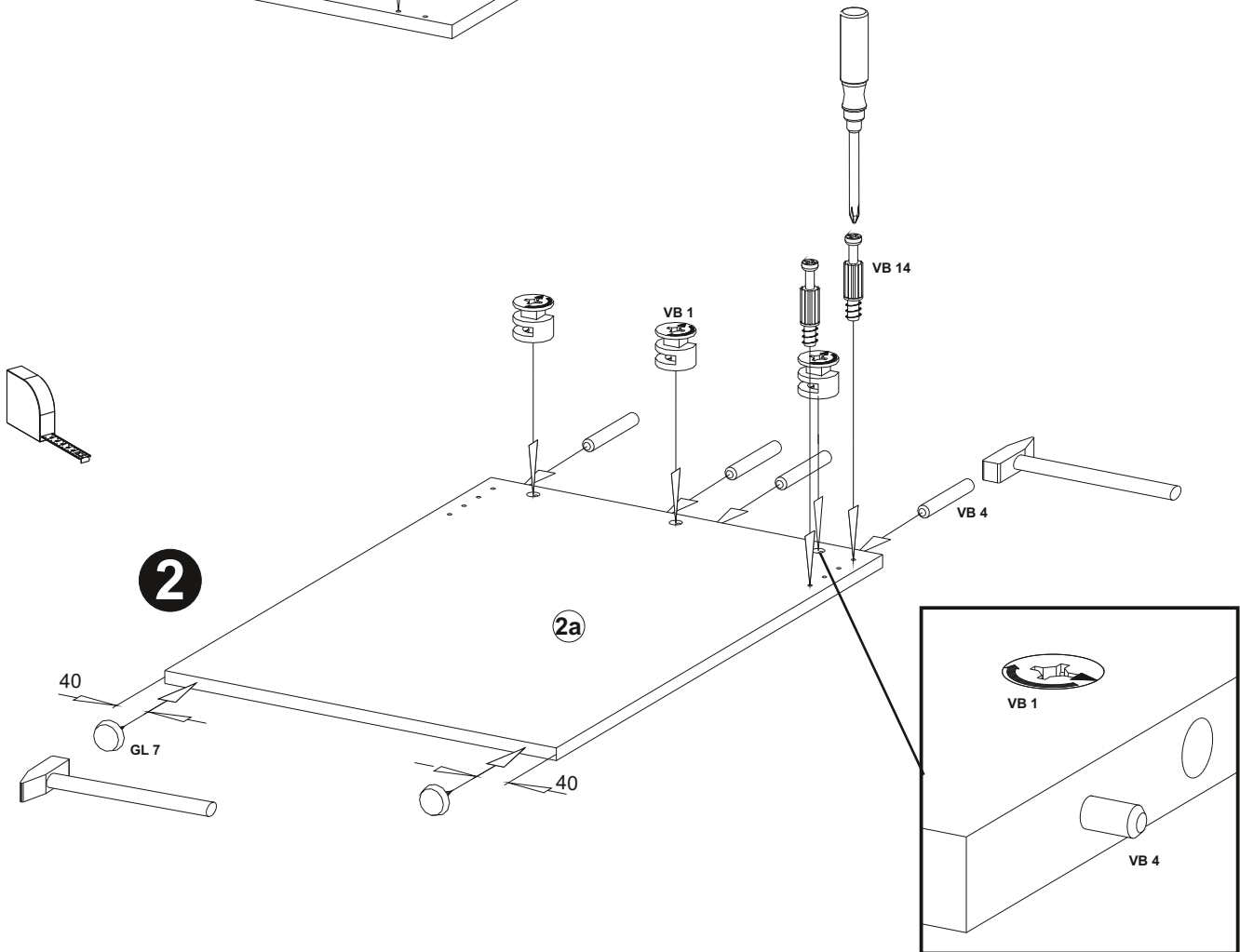
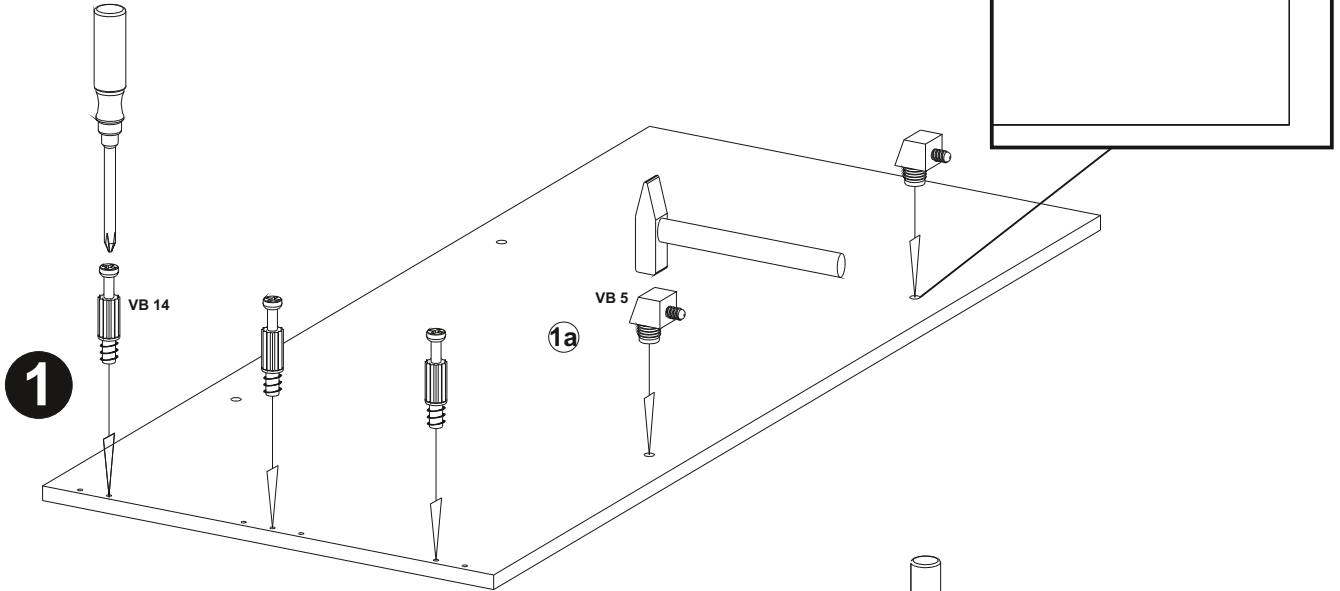

# E2

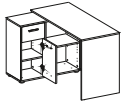
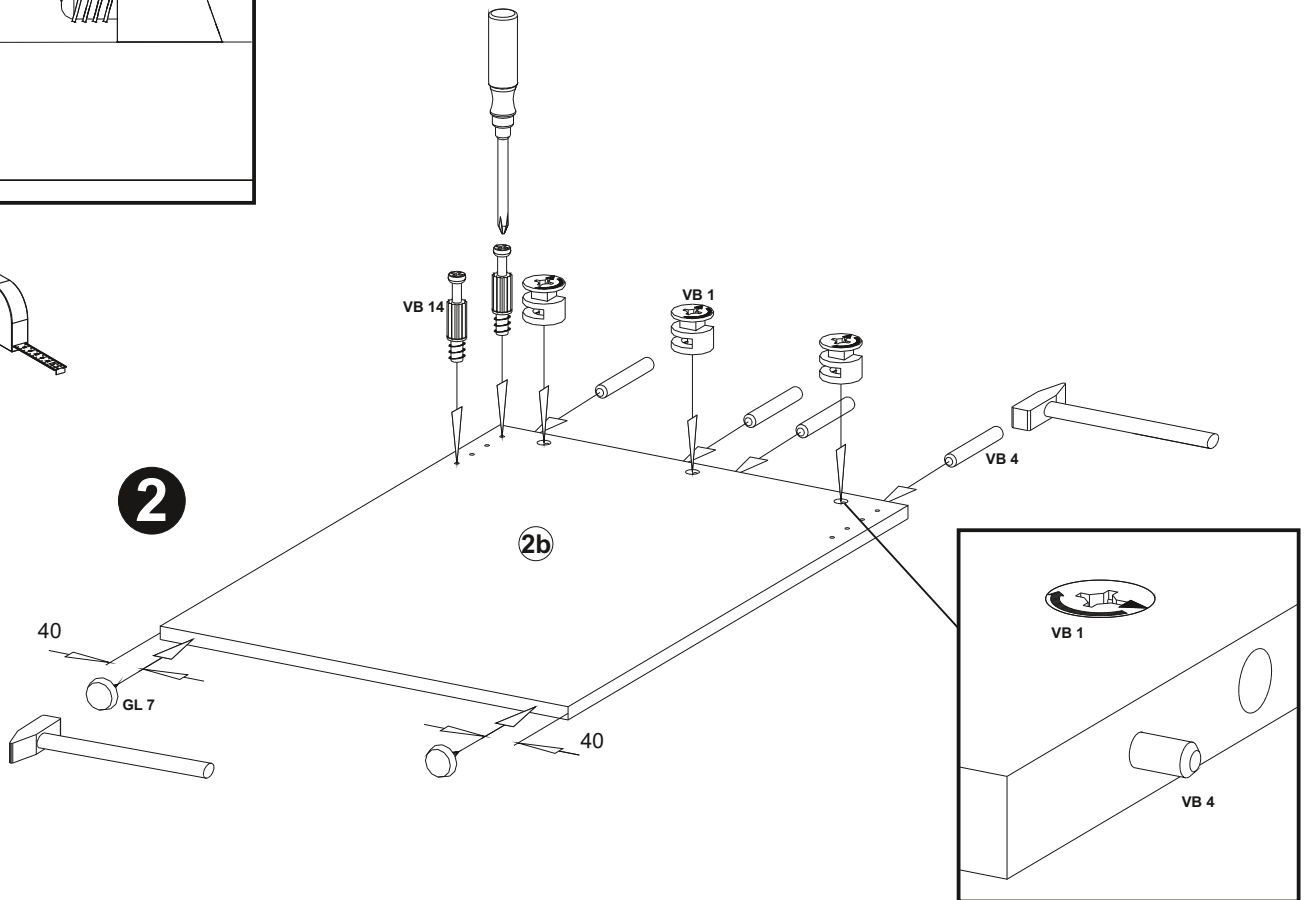
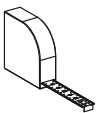
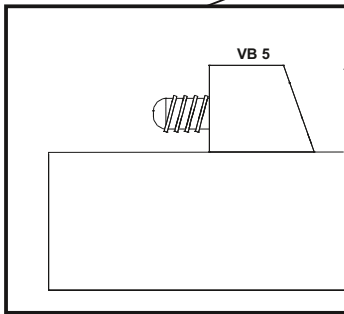
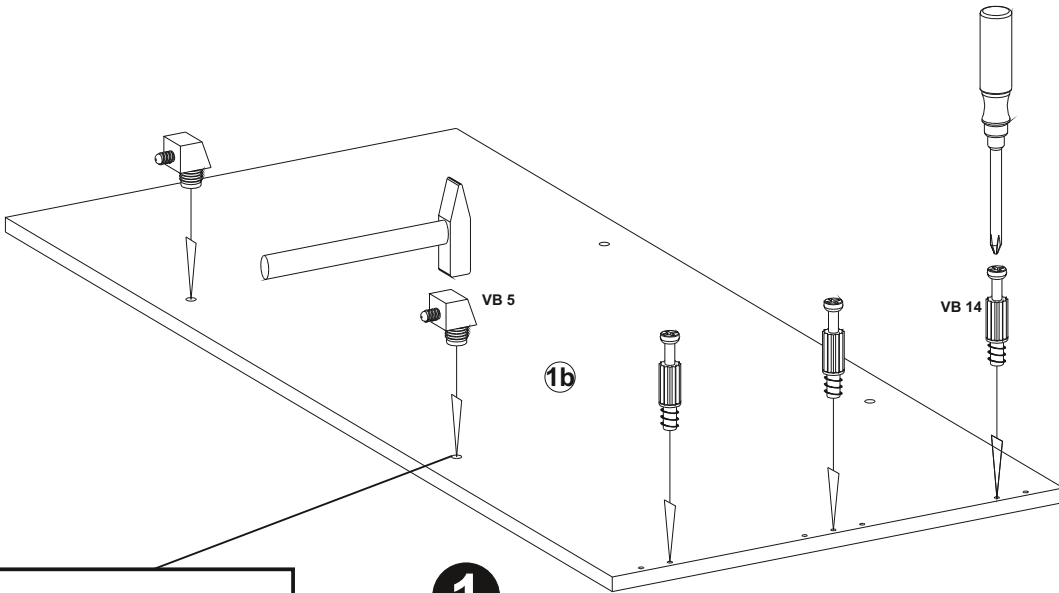
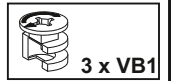
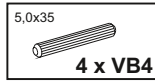
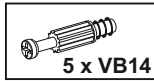
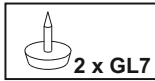
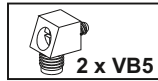
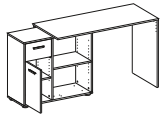
**B****D**

# F1

**A**

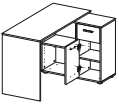

**C**

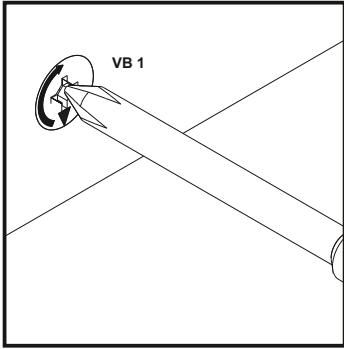
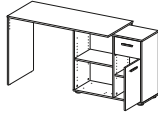

**1**

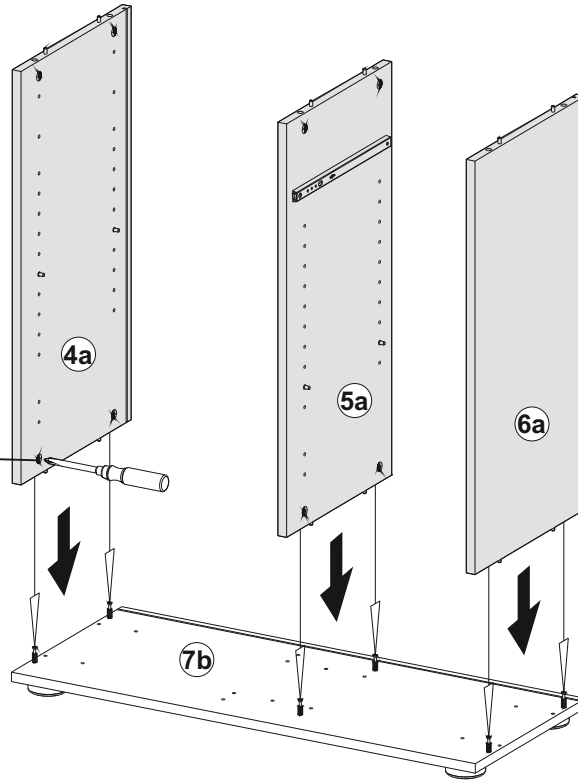

**2**

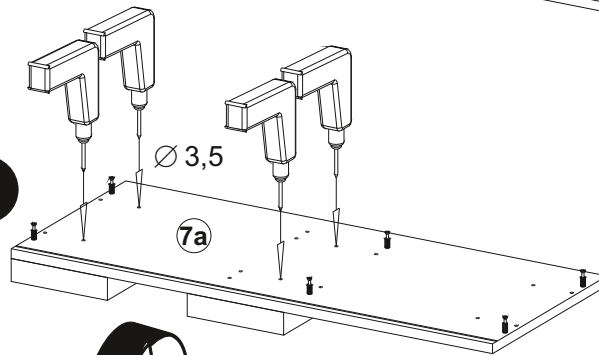

180°

**3**

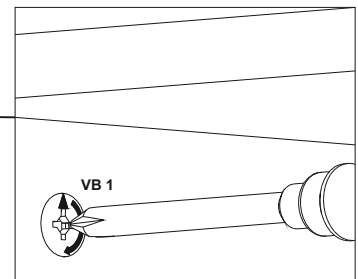
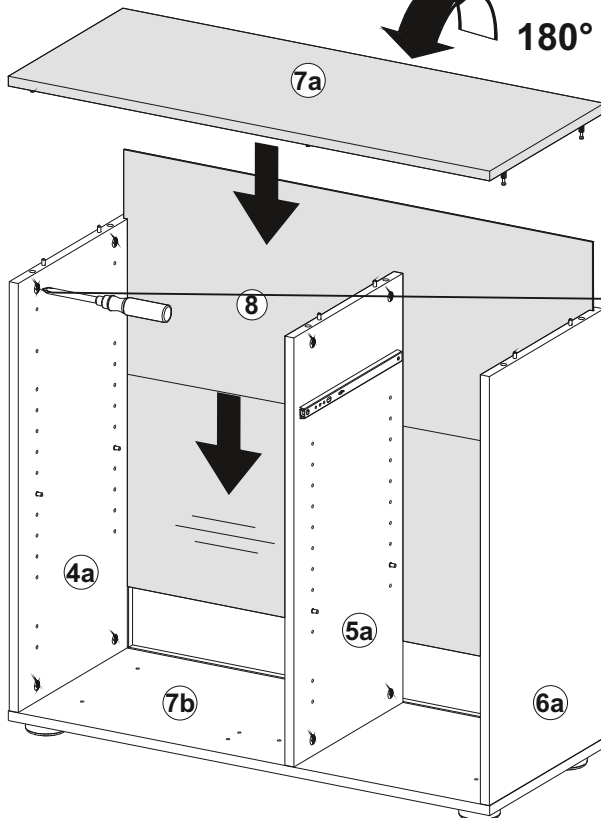

# G1

**A**

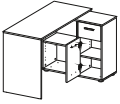

**C**

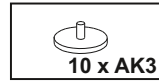
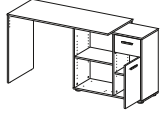

10 x AK3



4 x ZB 4

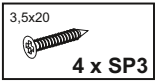

4 x SP3



4,0x45  
4 x SR 4

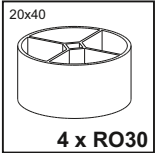

20x40  
4 x RO30

**1**

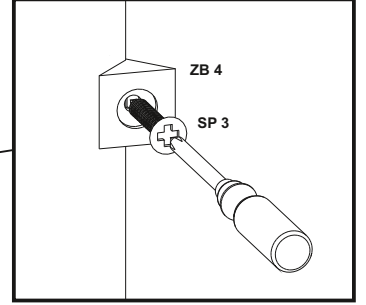
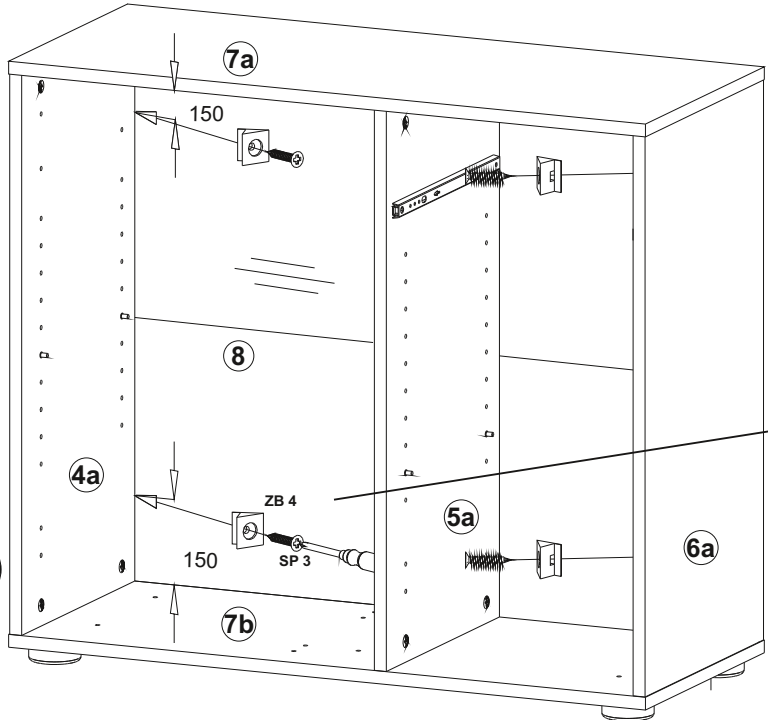

**2**

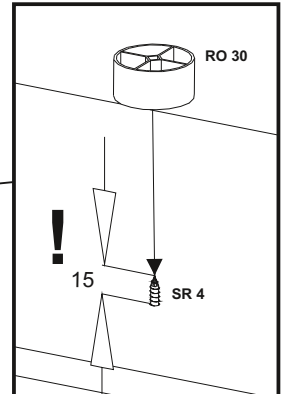
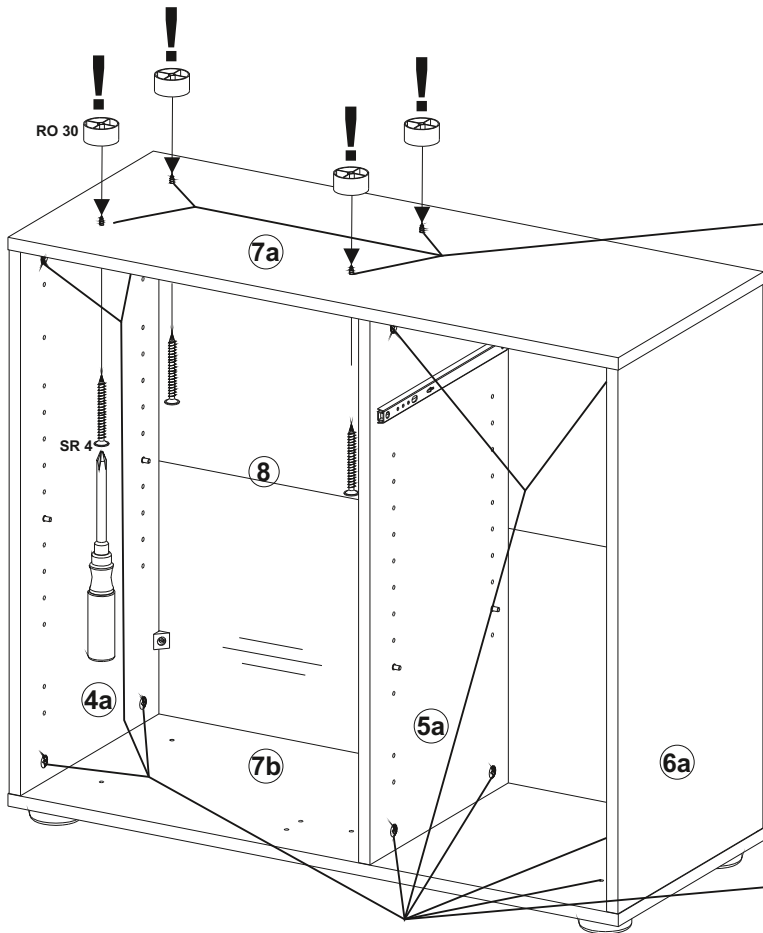

# H1

**A**

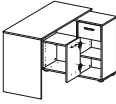

M4x8  
2 x SG1

2 x AK2

1 x GR18

3,5x25  
2 x SR1

1 x WI3

3,0x13  
1 x SP7

**1**

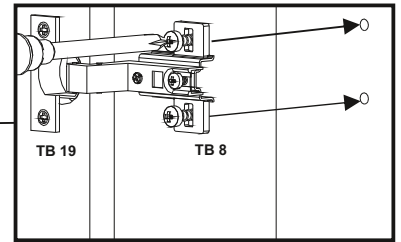
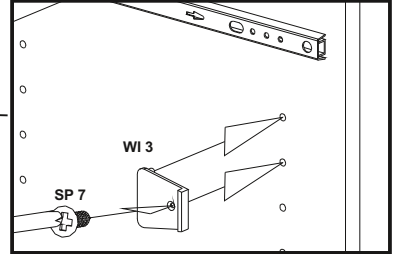
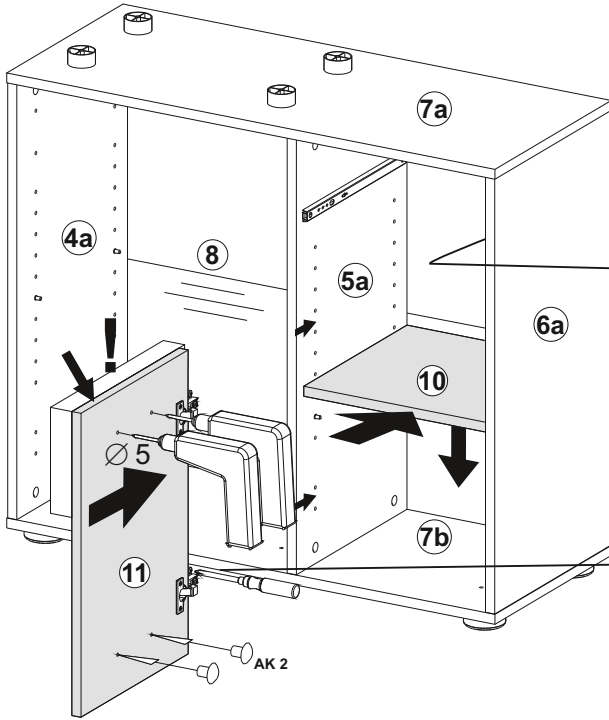

**2**

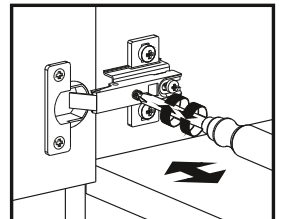
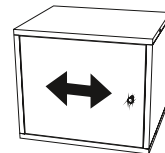
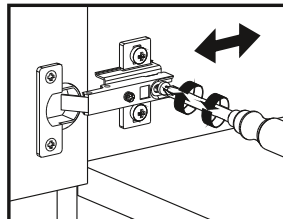
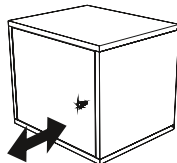
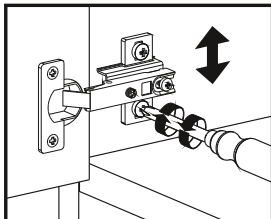
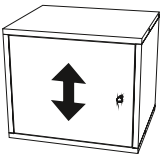
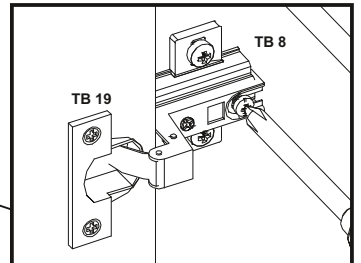
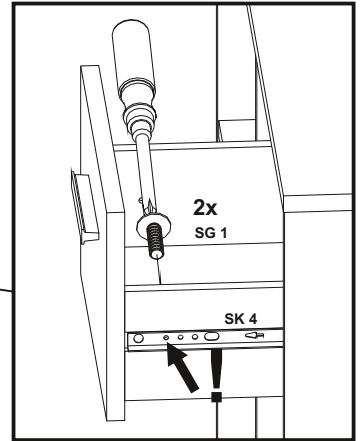
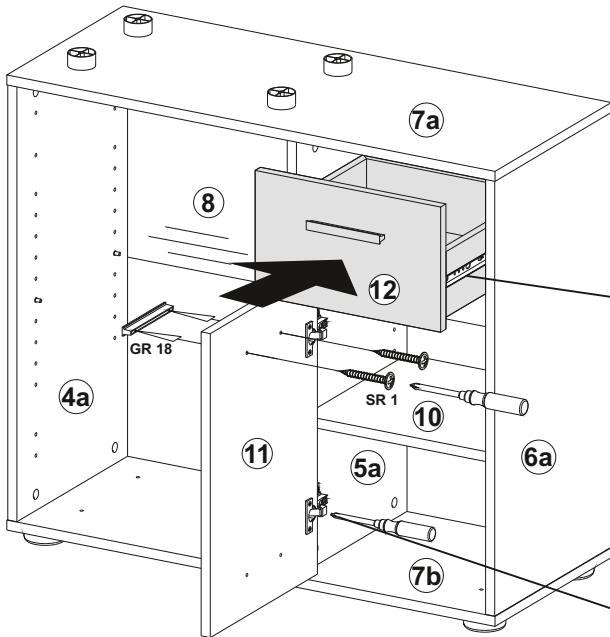

# 11

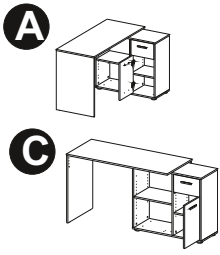

- 4 x AK2
- 5 x AK3
- 1 x Wi8
- 2 x SO14
- 4,0x13

**1**

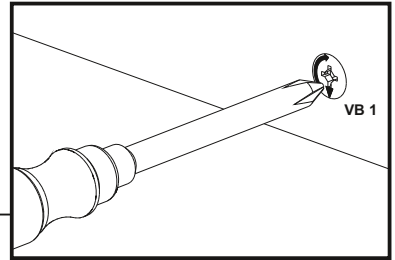
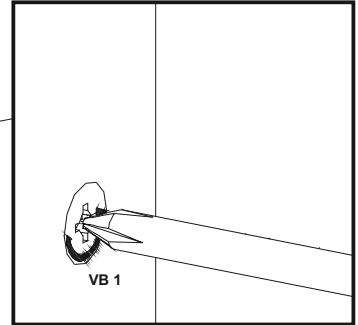
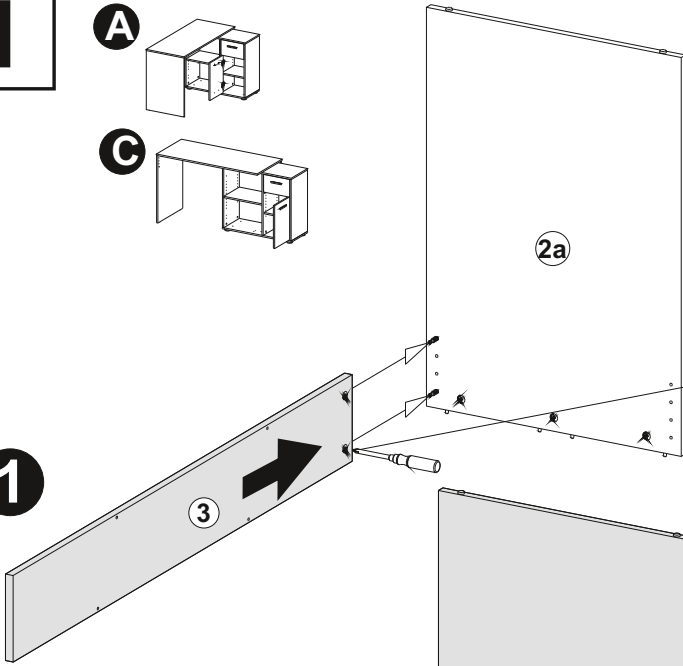

**2**

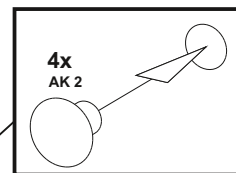
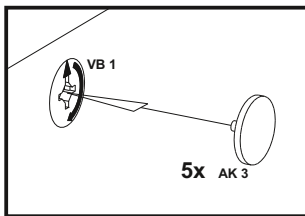
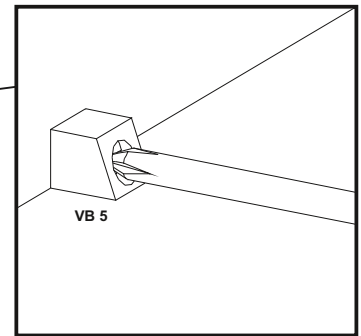
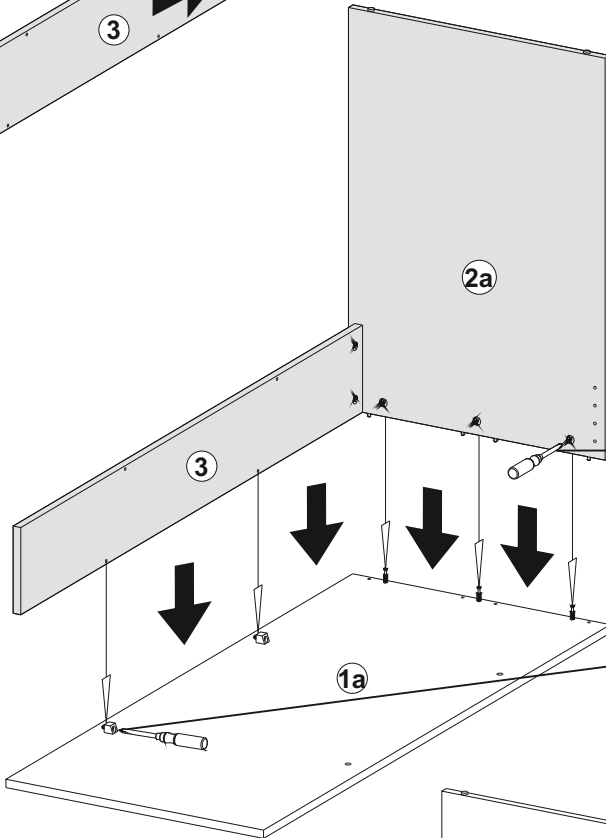

**3**

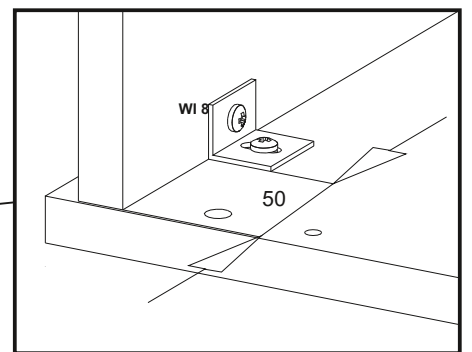
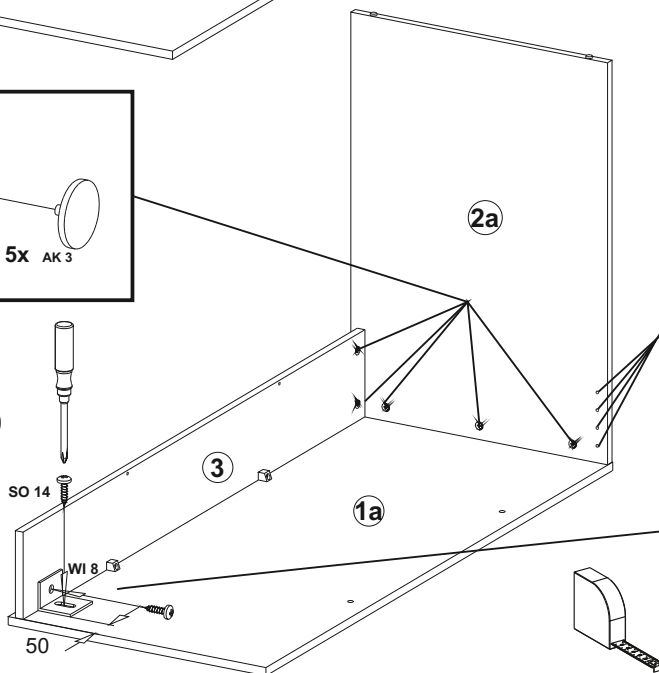

# J1

## A

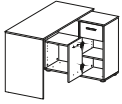

3,5x22  
2 x SP10

4x25  
2 x SP11

4 x AK1

### 1

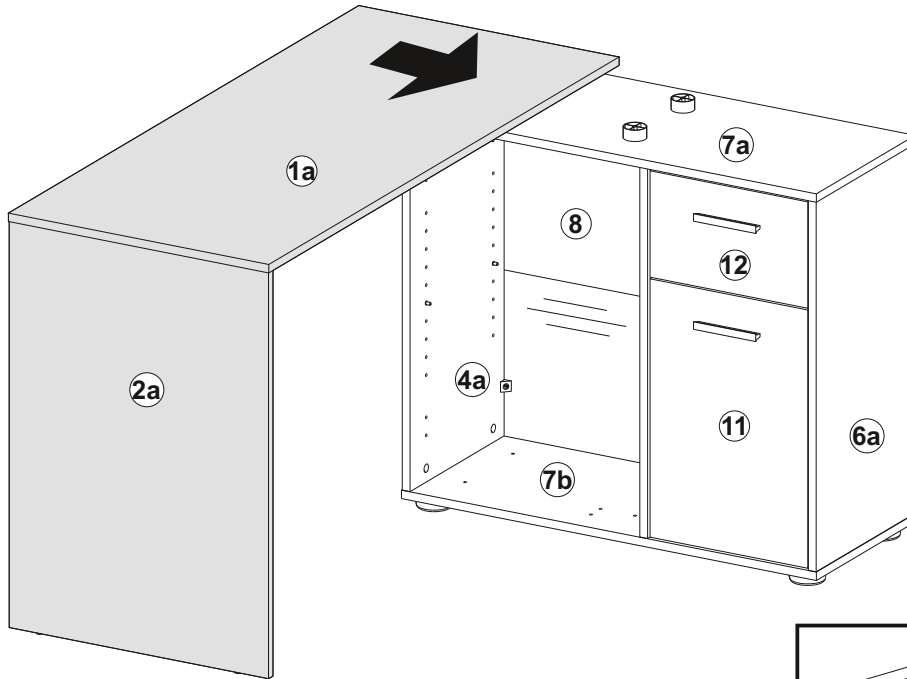

### 2

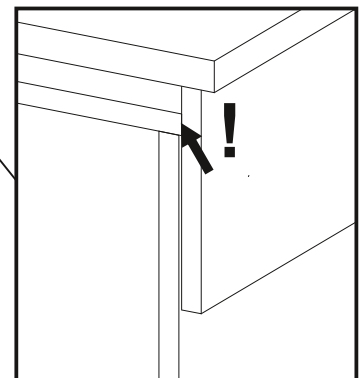
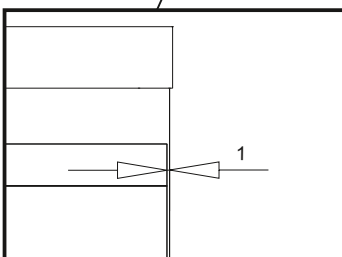
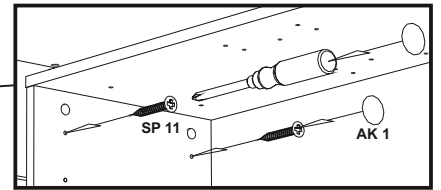
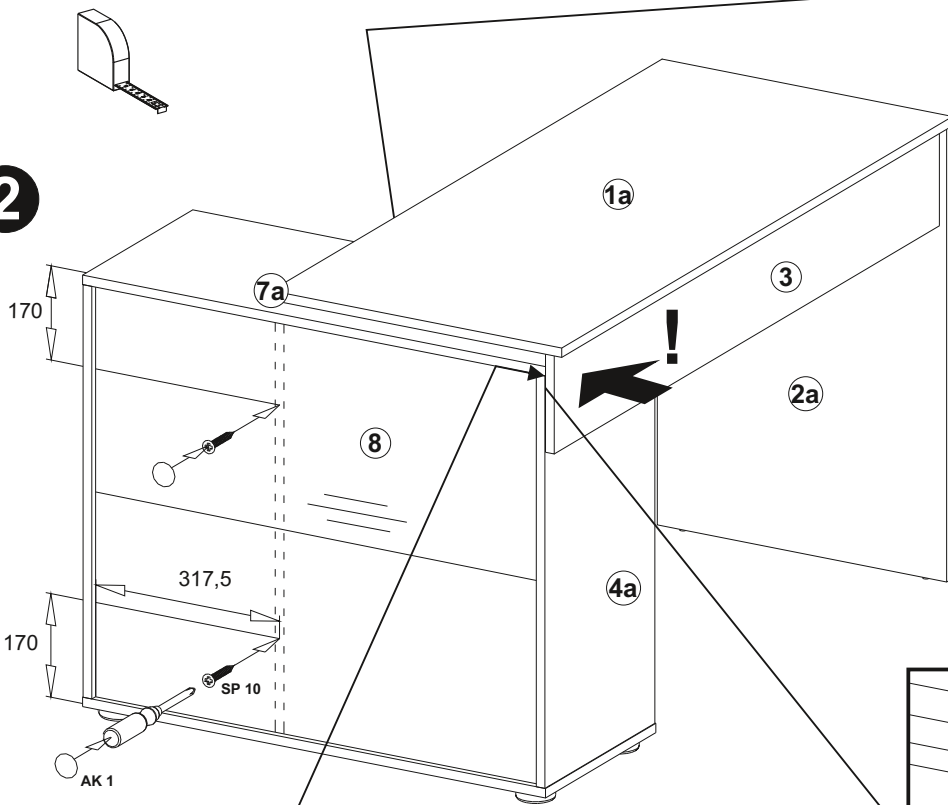

# K1

**A**

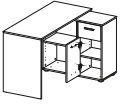

10 x AK2

**1**

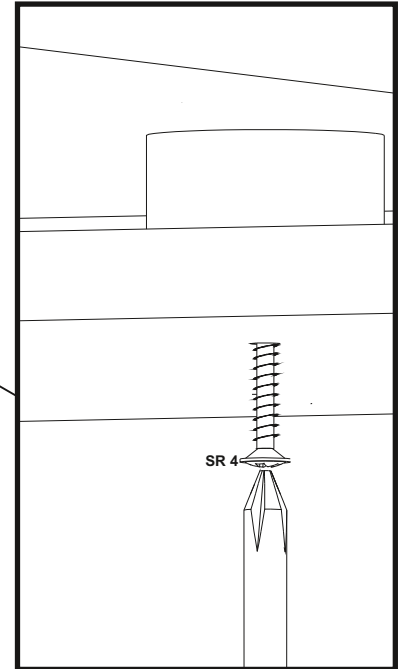
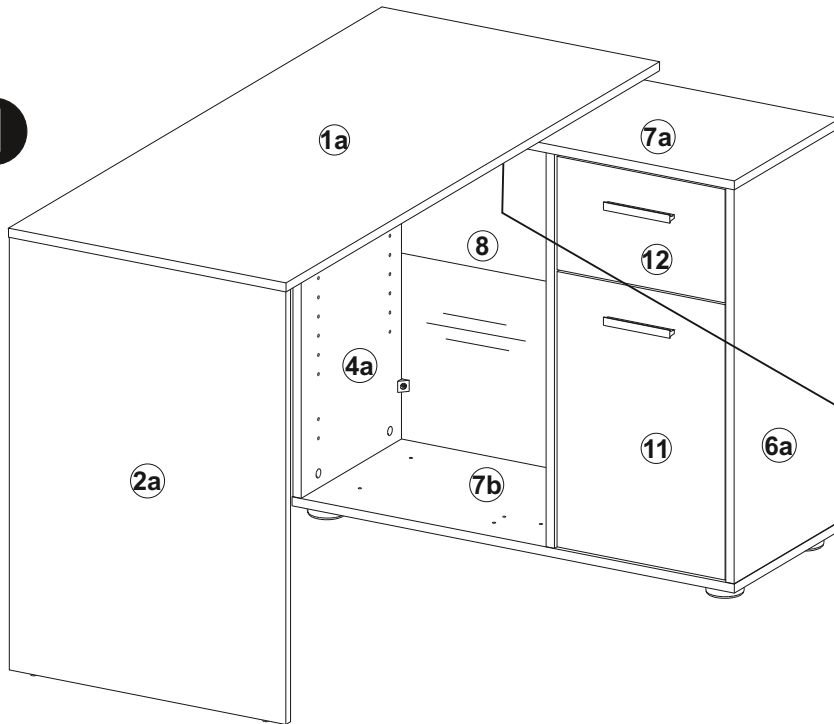

**2**

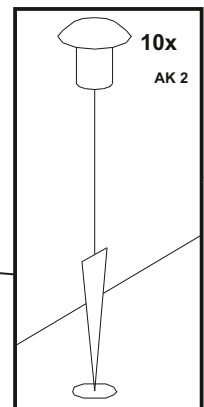
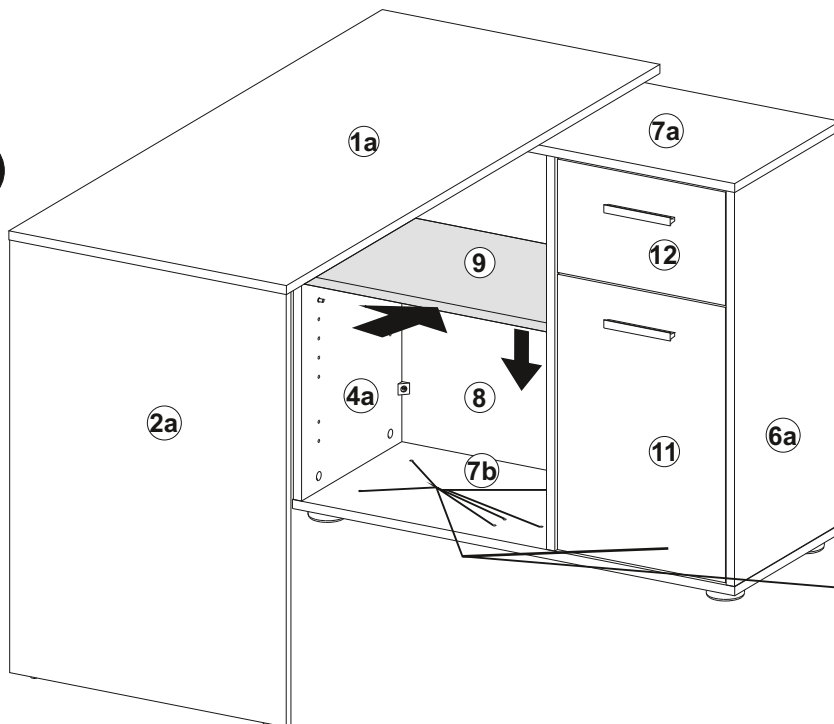

# F2

**B**

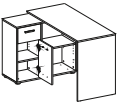

**D**

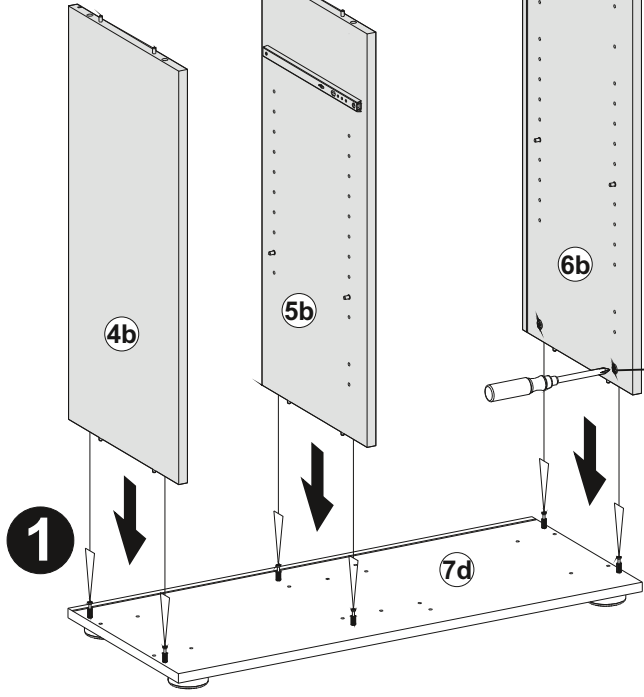
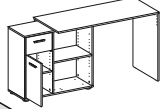

**1**

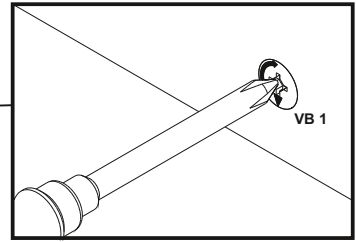

**2**

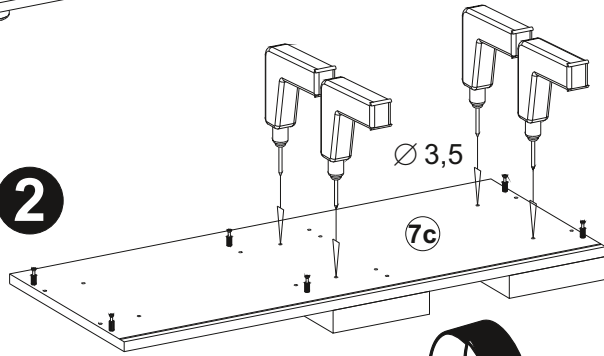

180°

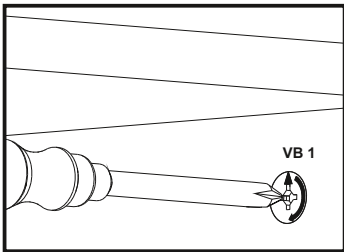

**3**

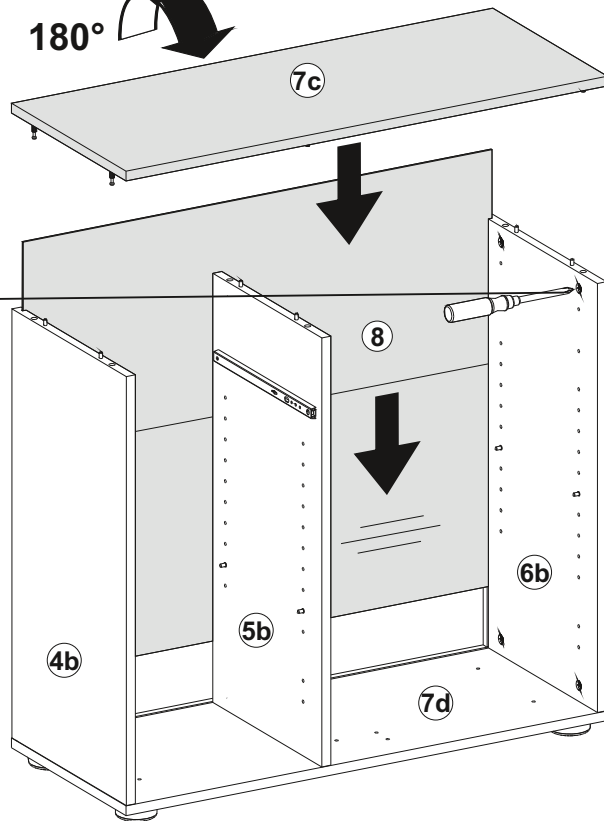

# G2

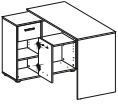
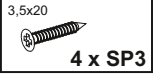
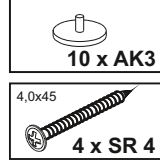
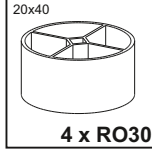
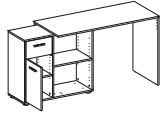
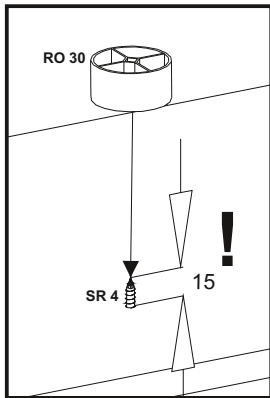
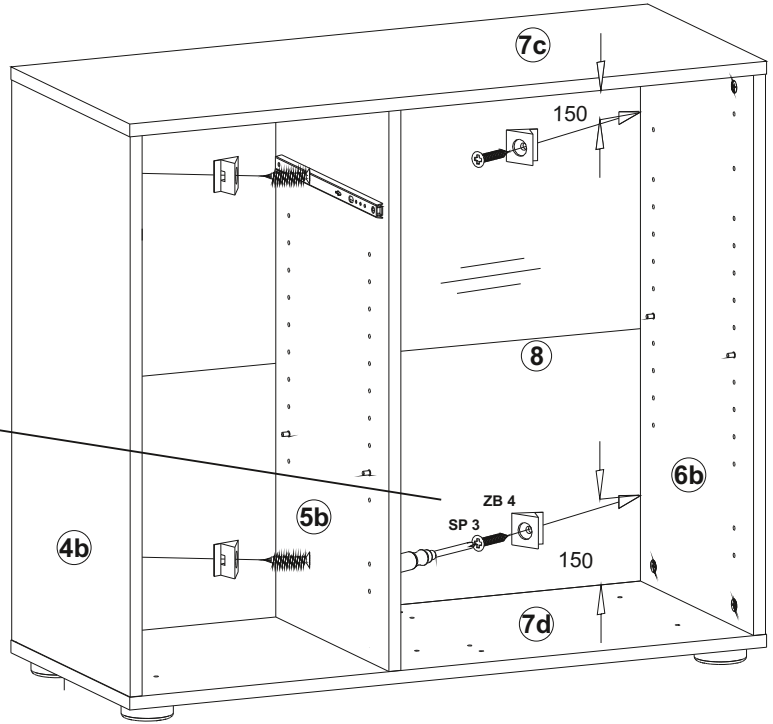
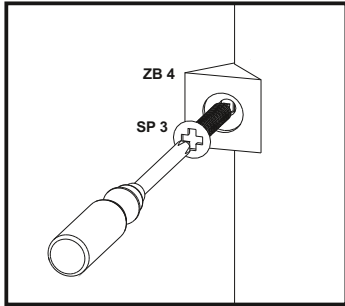
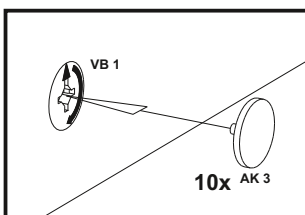
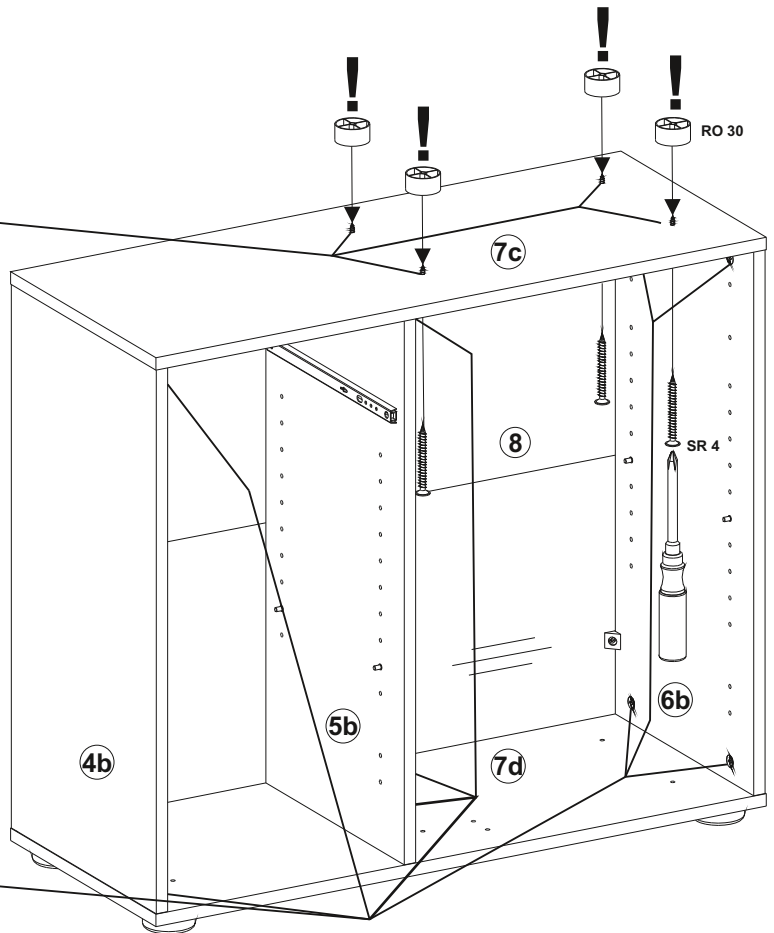
**B****D****1****2**

# H2

## B

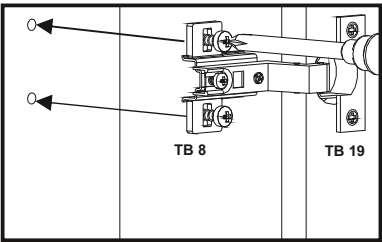
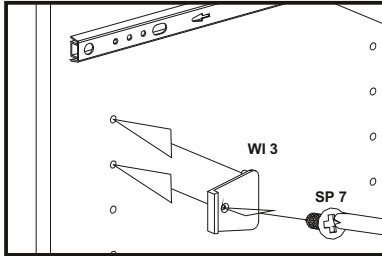
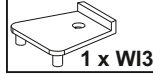
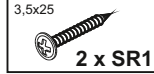
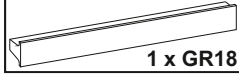
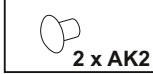
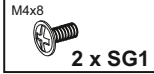
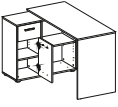

### 1

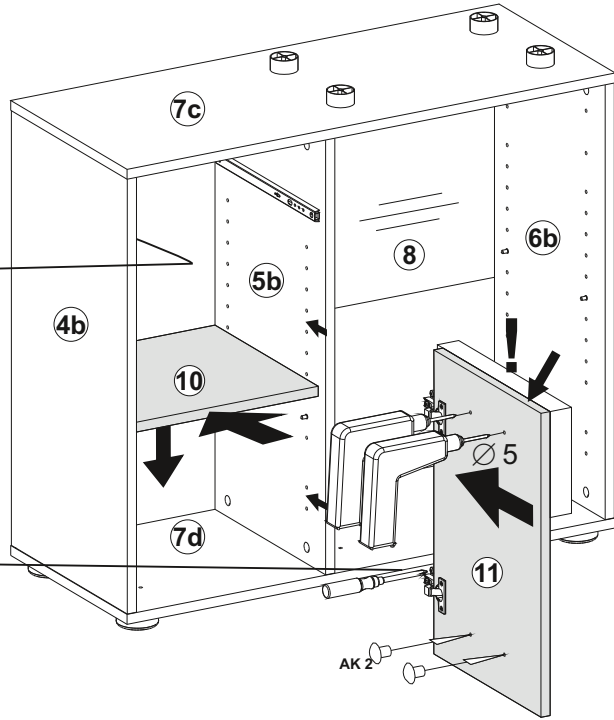

### 2

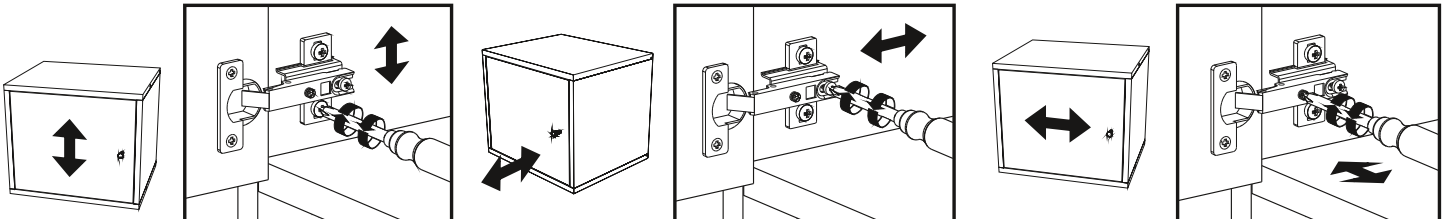
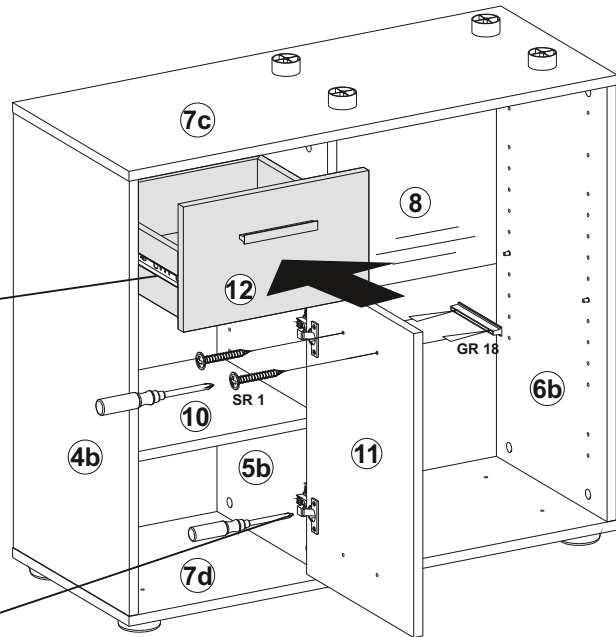
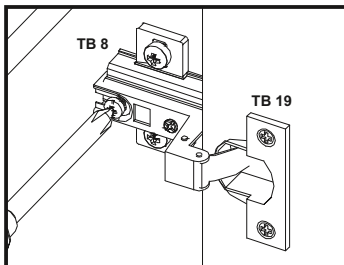
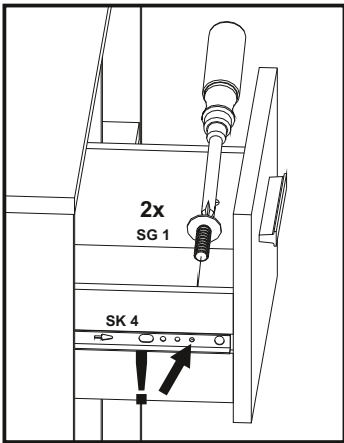

# 12

**B**

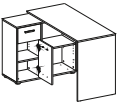

**D**

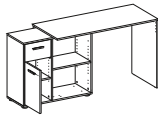

**1**

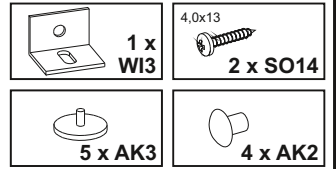
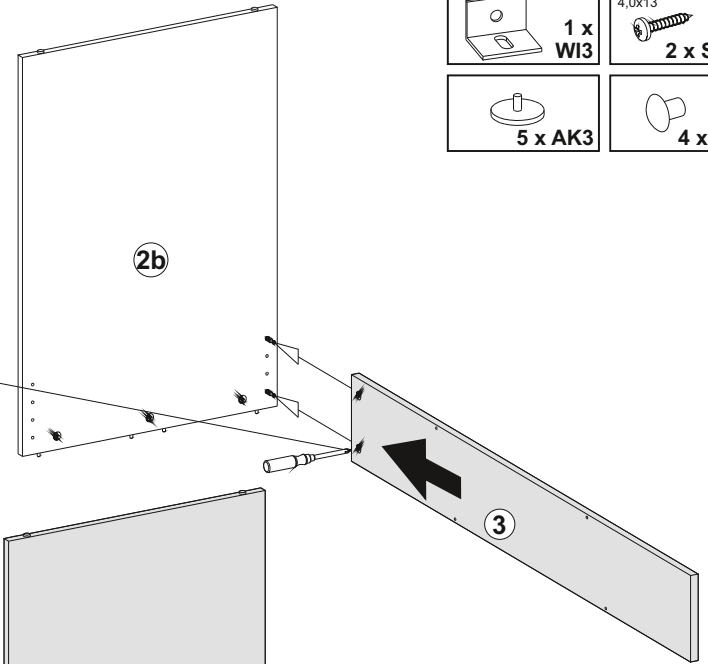
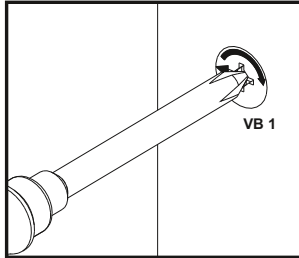

**2**

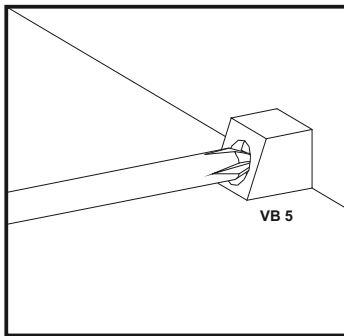
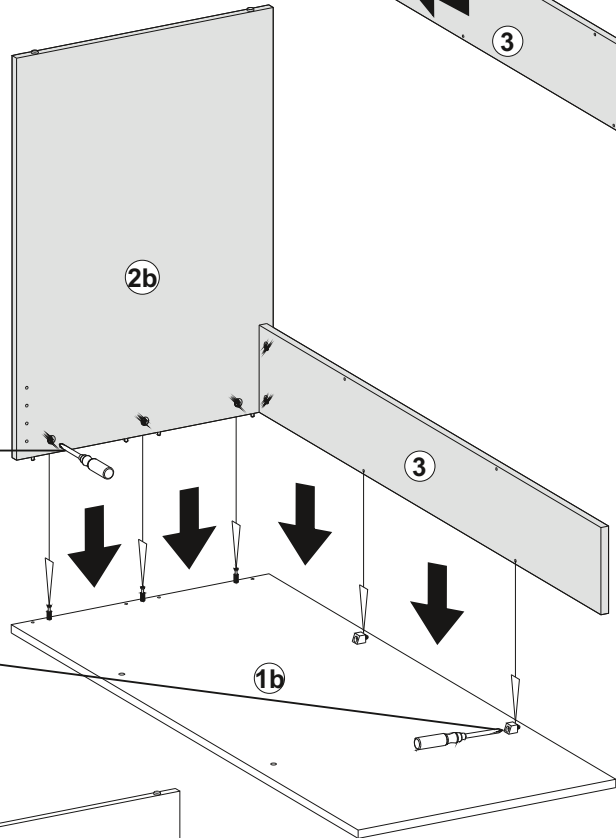
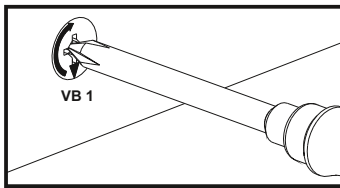

**3**

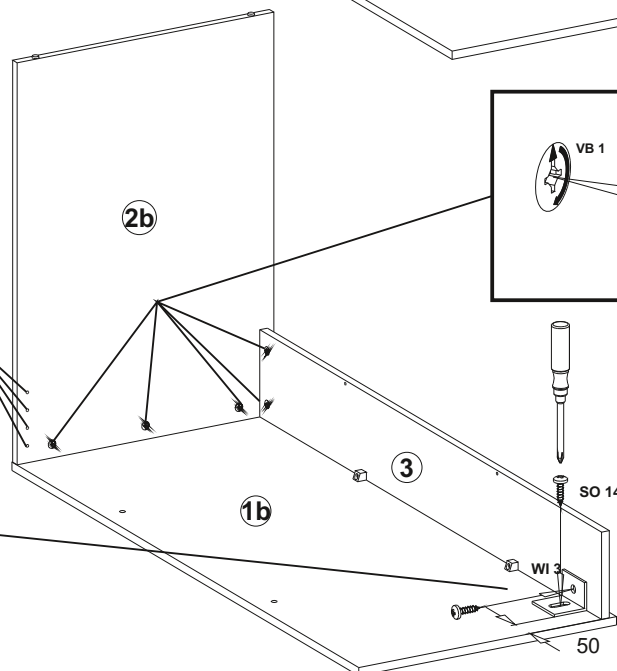
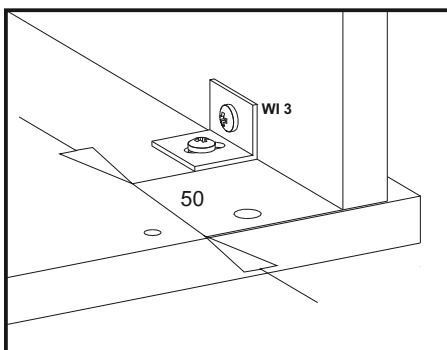
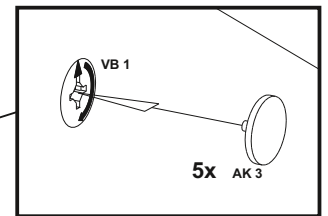
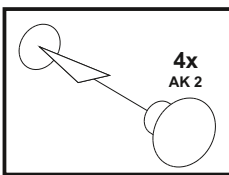

# J2

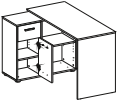
**B**

3,5x22  
2 x SP10

4x25  
2 x SP11

4 x AK1

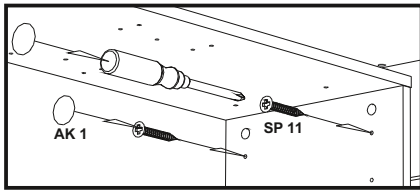
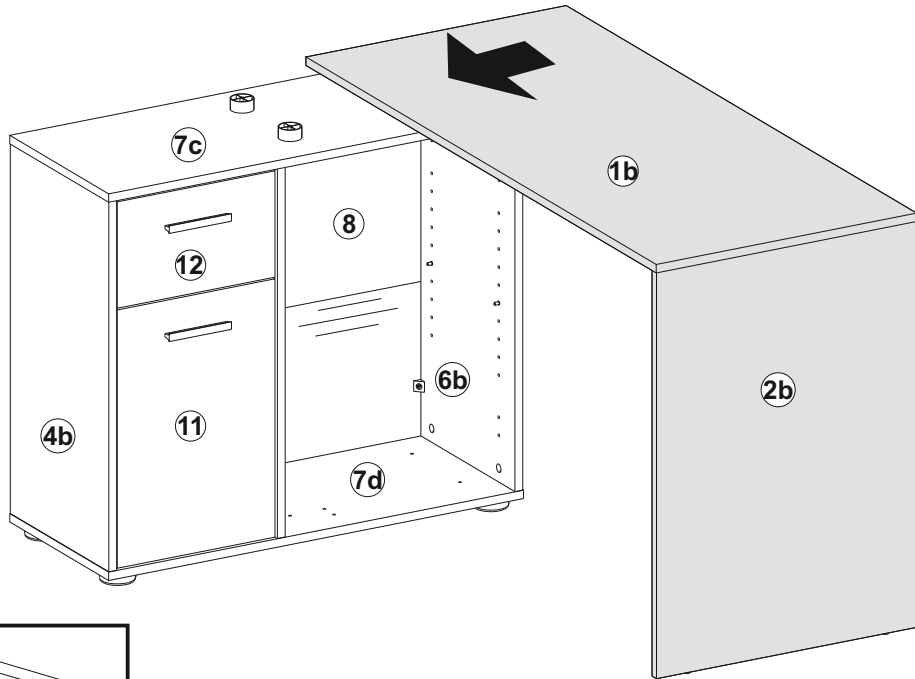
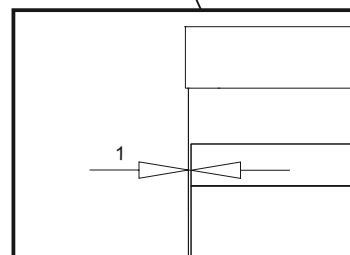
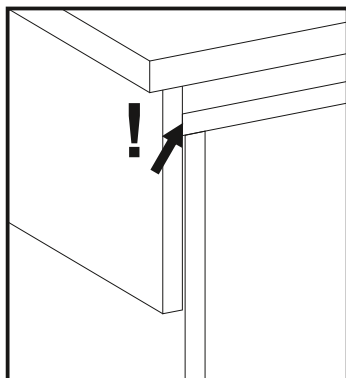
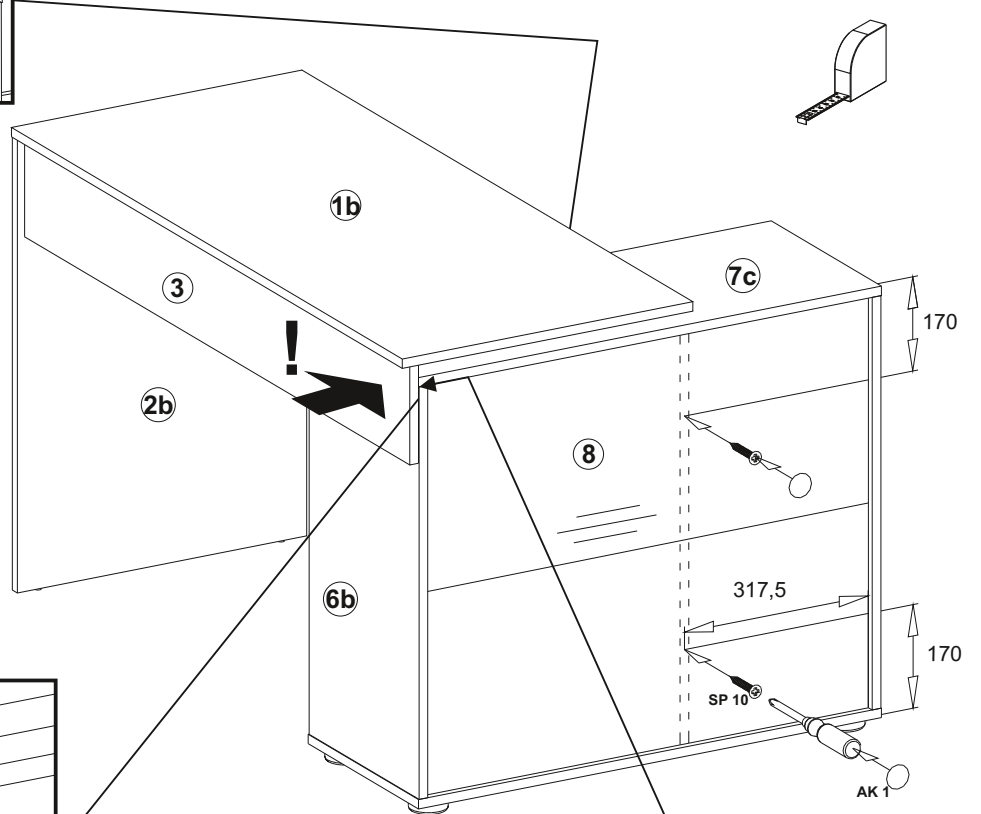
**1****2**

# K2

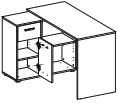
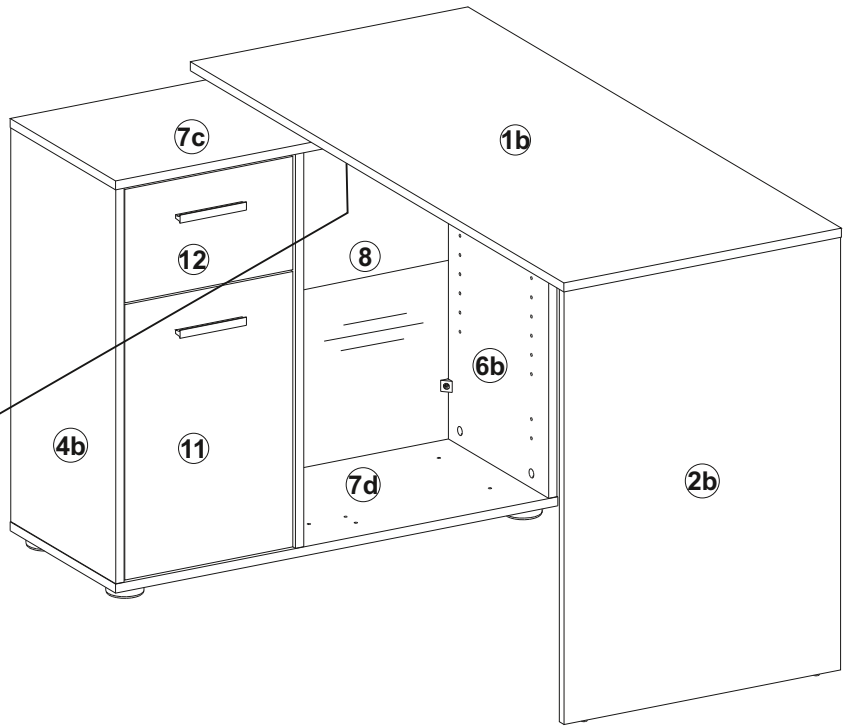
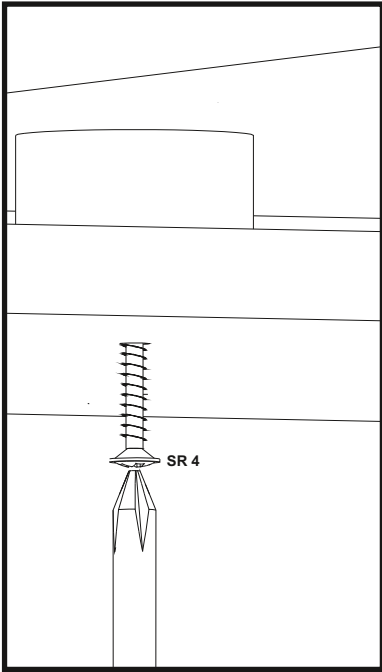
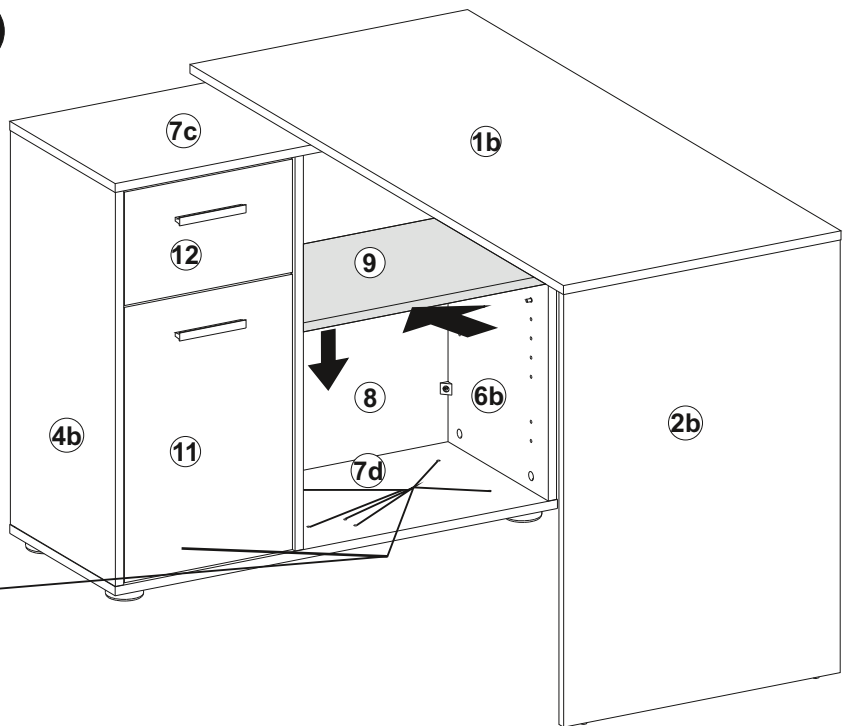
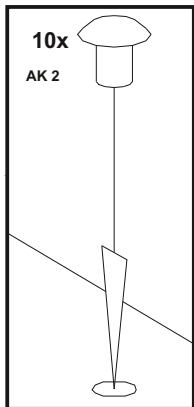
**B**  
10 x AK2**1****2**

# H3

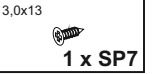
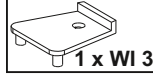
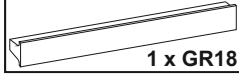
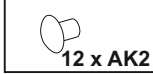
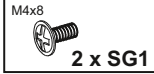

1

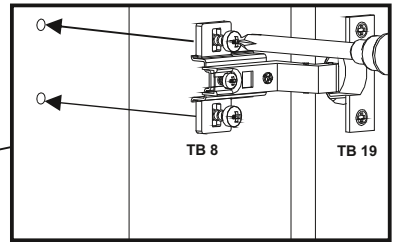
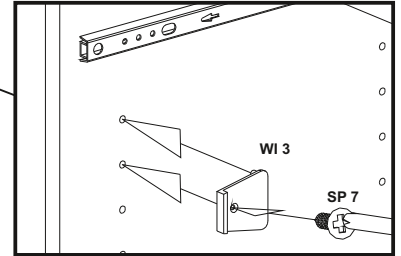
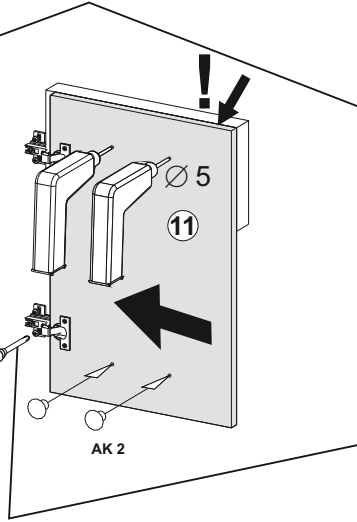
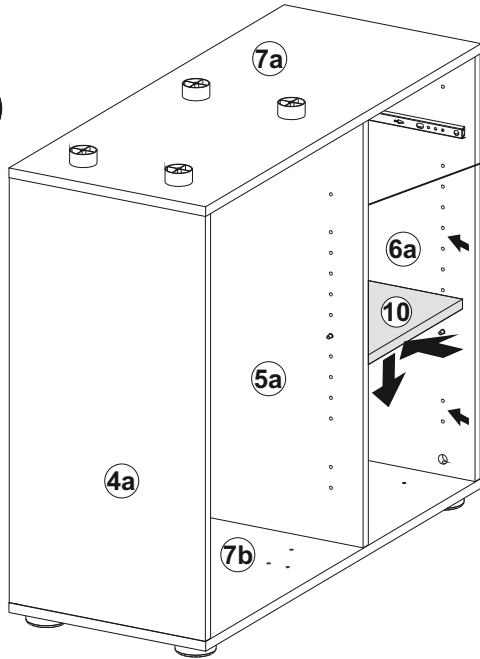

2

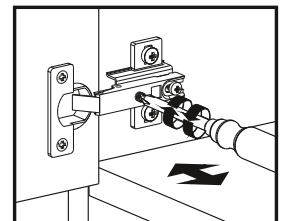
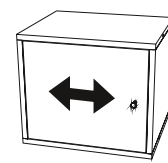
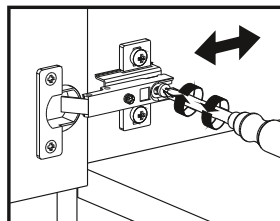
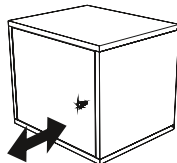
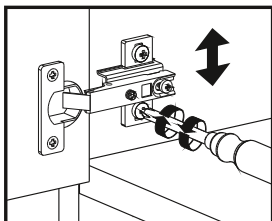
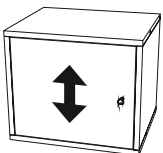
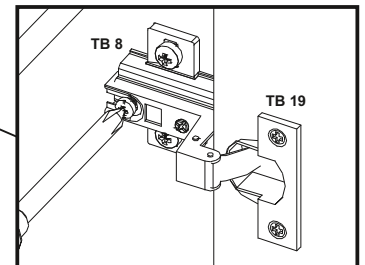
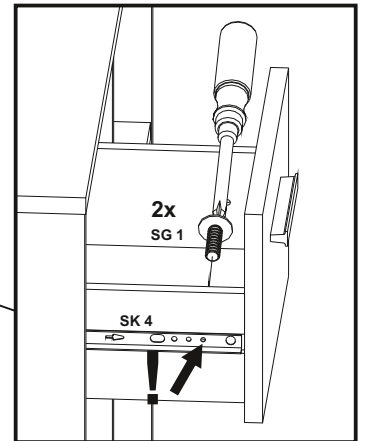
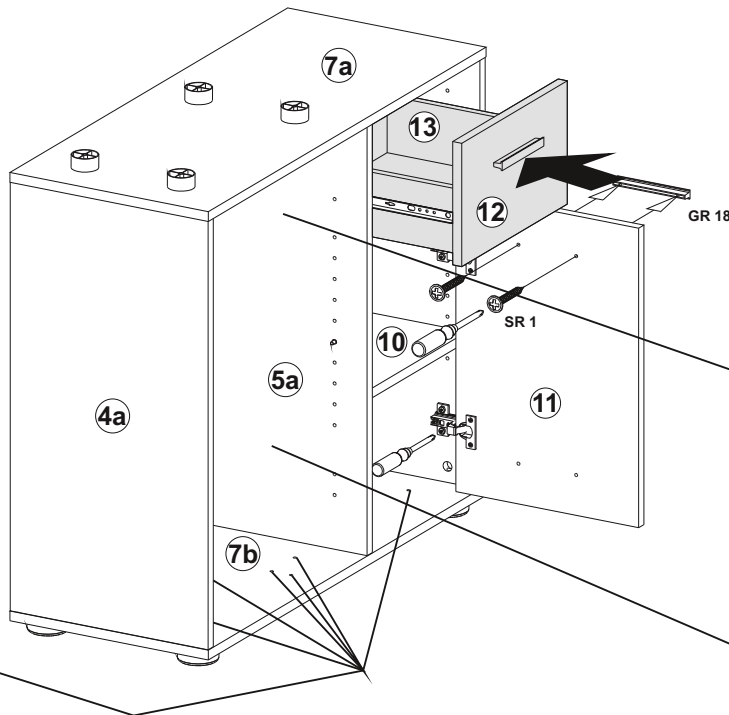
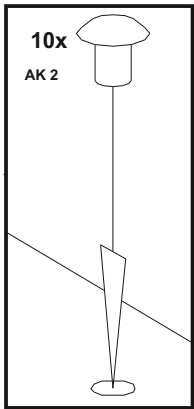

# J3

## G

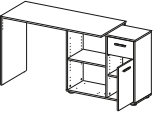

3,5x22



2 x SP10



2 x AK1

### 1

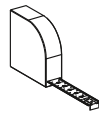
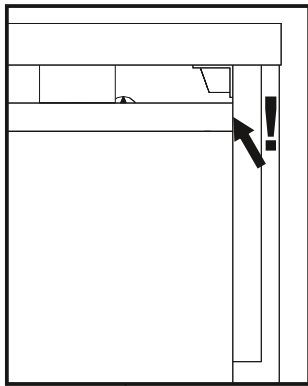
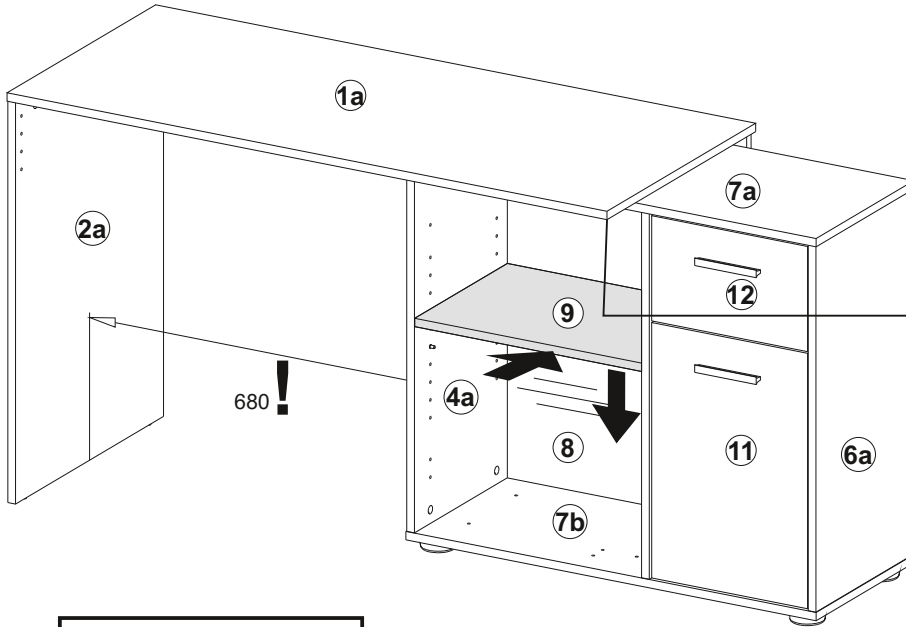

### 2

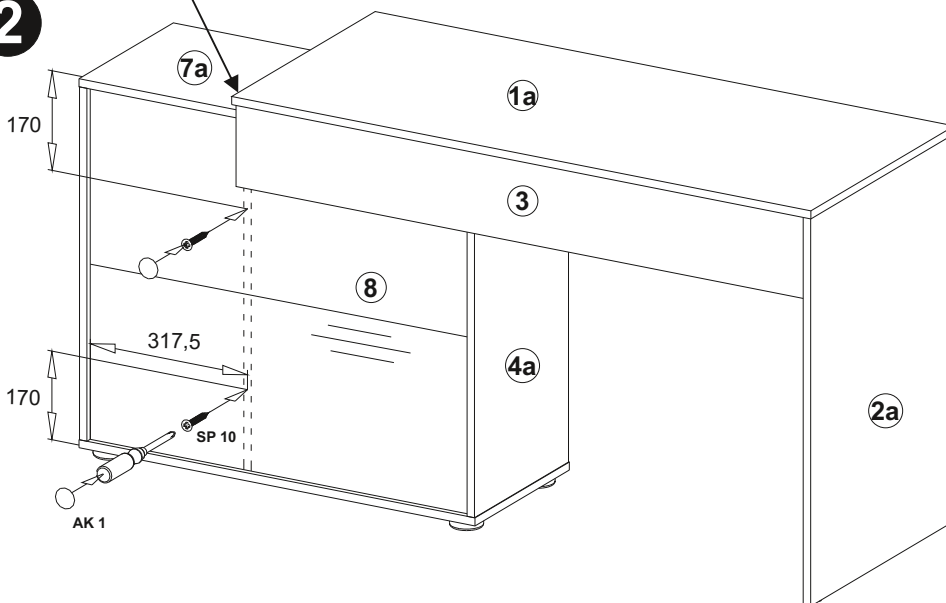

# H4

D

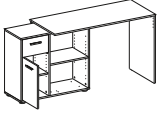

M4x8  
2 x SG1

12 x AK2

1 x GR18

3,5x25  
2 x SR1

1 x WI 3

3,0x13  
1 x SP7

1

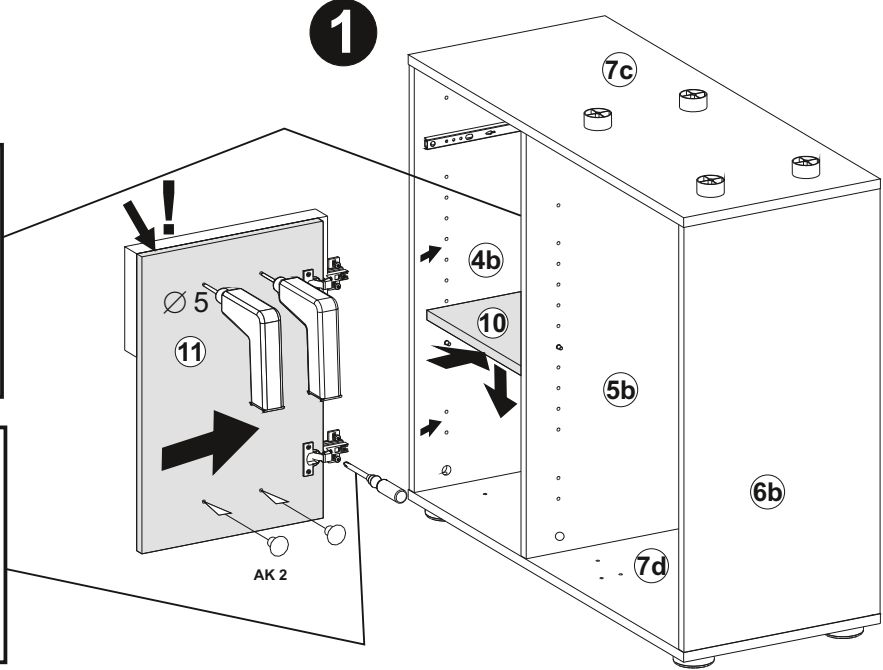
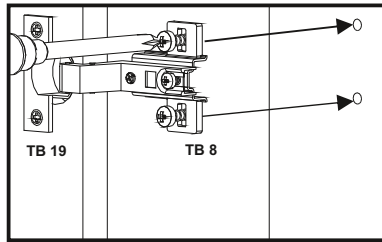
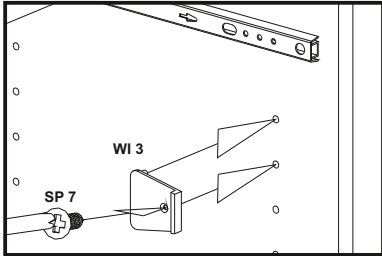

2

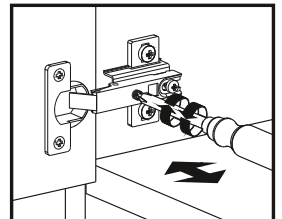
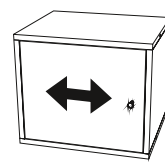
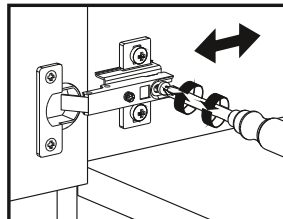
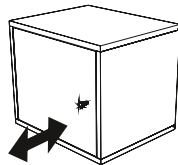
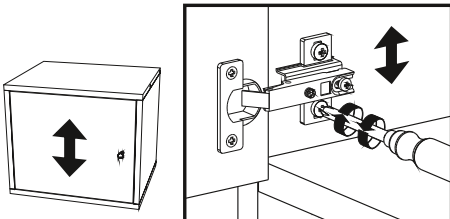
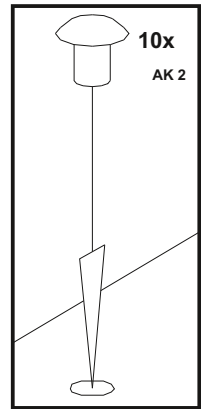
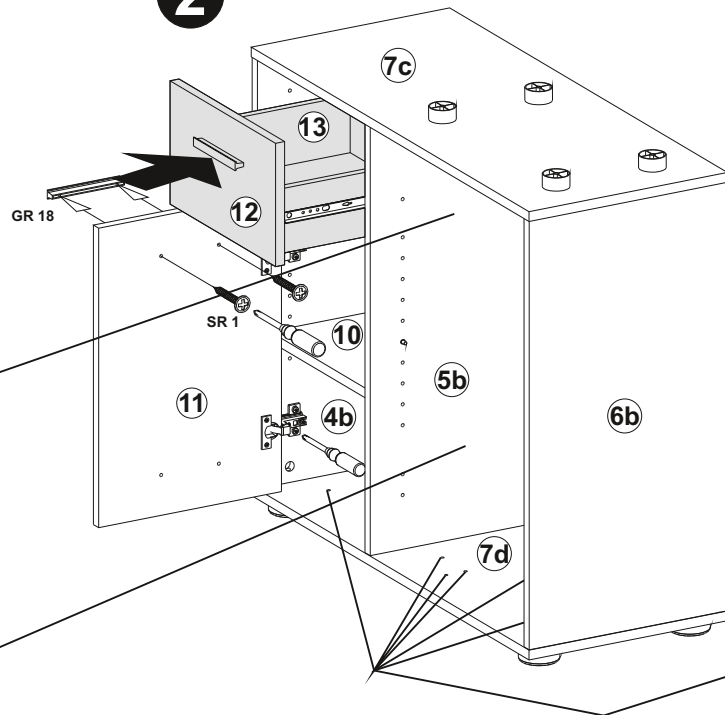
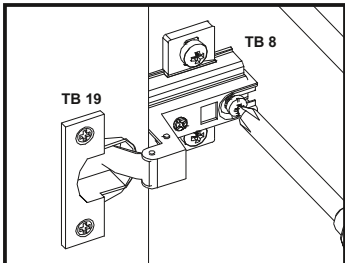
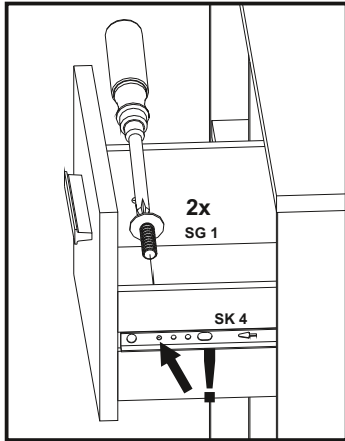

# J4

## D

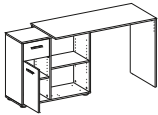

3,5x22



2 x SP10



2 x AK1

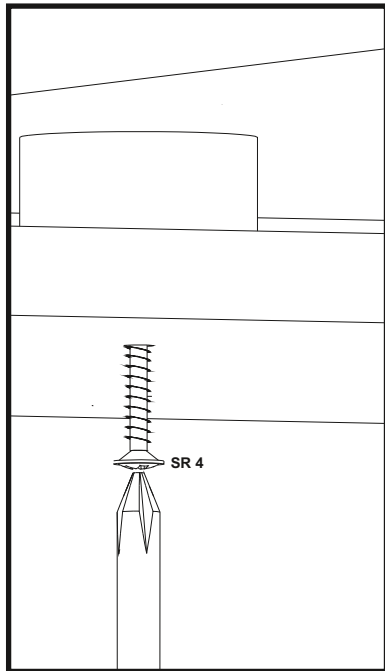

### 1

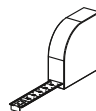
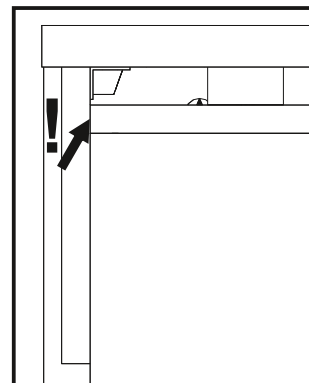
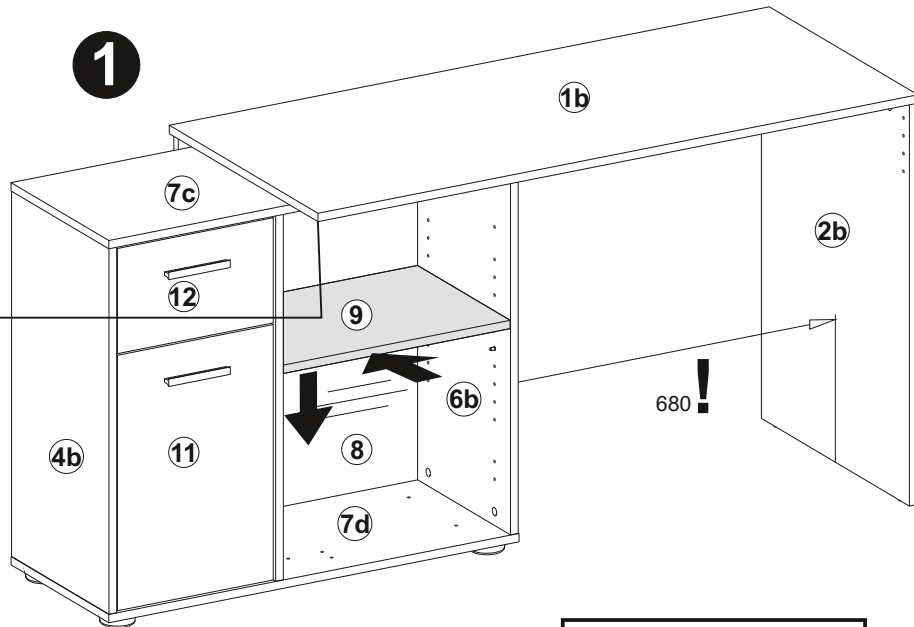

### 2

