

ASSEMBLY INSTRUCTIONS PEDESTAL TABLE

ASSEMBLY
REQUIREMENTS

2-Person
Assembly

Assembly Time: 30 minutes
(Approximate)

Tools Required: Phillips Screwdriver
(Not Provided)



Thank you for purchasing our product!

Please refer and use this assembly instruction to assemble the product. Contact our customer service department in case there are any missing or damage parts or hardware. Replacement parts are normally shipped within 2 or 3 days.

Email: replacementparts@buylateral.com
Within 30 days from delivery date

PRODUCTS PURCHASED THROUGH OUR AUTHORIZED VENDORS
ONLY ARE ELIGIBLE FOR REPLACEMENT PARTS

We appreciate your business!

**THIS PRODUCT IS FOR INDOOR AND HOUSEHOLD
USE ONLY – NOT FOR COMMERCIAL USE.**



ASSEMBLY PREPARATION

1. Remove all packaging materials, staples and packing straps from the carton.
2. Refer to Parts List and Hardware List, and ensure parts and hardware are correct before assembly. Contact customer service for missing parts.
3. Place all wooden parts on a clean, flat and soft surface (e.g. carpet or rug) to prevent scratch and damage to parts.

SAFETY PRECAUTION

1. KEEP ALL HARDWARE PARTS OUT OF REACH OF CHILDREN.
2. DISPOSE PLASTIC PACKAGING MATERIAL IMMEDIATELY TO AVOID ANY RISK OF SUFFOCATION TO CHILDREN AND ANIMALS.

TIPS FOR ASSEMBLY





1. Allow ample room for assembly and assemble the product near where the product will be placed.
2. Assemble the product on a surface that does not scratch or damage the exterior gloss and finish of the furniture.
3. Identify all of the parts, hardware and quantities required for each step.
4. During assembly, do not over-tighten any fittings as this may cause damage.
5. DO NOT USE POWER TOOLS TO ASSEMBLE THIS PRODUCT.
6. Always place the product on a flat, level surface.
7. Do not sit or stand on the partially assembled product; only use the product for which it is intended.

CARE AND MAINTENANCE









- Use a slightly damp cloth to clean the product. Do not use bleach or abrasive cleaning material.
- Check all the fittings periodically and re-tighten as necessary. Do not use the product if any of the parts is damaged or broken.
- Never allow any kind of liquid to remain on your furniture. Absorption can cause wood to warp or delaminate.
- Do not place hot items (e.g. hot drinks) directly onto the wood surface.
- Do not drag and/or pull the furniture.

ASSEMBLY INSTRUCTIONS PEDESTAL TABLE

Parts List

Item	Description	Part	Qty
A	Table Top		1 PC
B	Pedestal Column		1 PC
C	Leg		4 PCS
D	Mounting Rail		1 SET

Hardware List

Item	Description	Part	Qty	Extra
E	Hex Nut		8 PCS	1 PC
F	Spring Washer		8 PCS	1 PC
G	Flat Washer (Large)		8 PCS	1 PC
H	Wrench		1 PC	
I	Adjustable Leg Stud		4 PCS	2 PCS
J	JCBC Bolt		4 PCS	1 PC
K	Allen Key		1 PC	
L	Wood Screw		16 PCS	1 PC
M	Flat Washer (Small)		16 PCS	1 PC

*Extra Hardware For Spare Use

Step 1

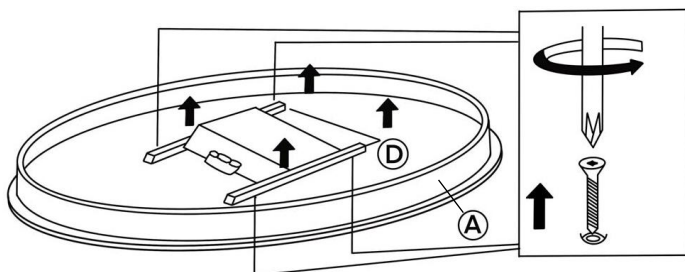

- With the assistance of another person, place Table Top (A) bottom side-up on a material that does not scratch or damage surface of the top side
- Remove the pre-assembled Mounting Rail (D) from the Table Top (A) by unscrewing the wood screws.
- Set (A) aside -- bottom-side up.

Step 2

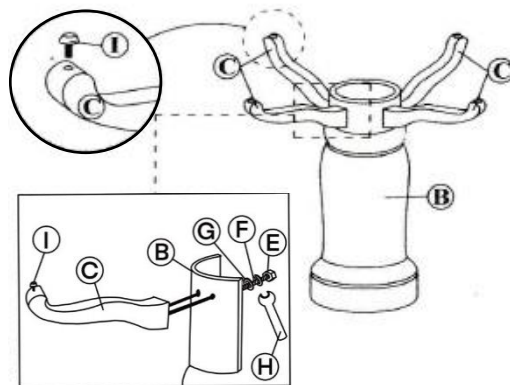

- Place Pedestal Column (B) as shown.
- Fit the two bolts on each Leg (C) through the paired bolt holes on (B) and fit the bolt ends with Flat Washer (G), Spring Washer (F) and fasten with Hex Nut (E).
- Repeat the above procedures for the other three legs.
- Screw in Adjustable Leg Stud at the end of each leg.

Step 3

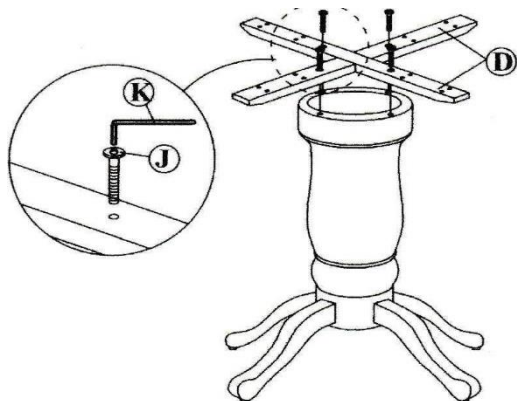

- Set Pedestal-Leg assembly from STEP 2 right-side up.
- Position Mounting Rail (D) to align the four bolt holes to the four bolt holes on the top edge of Pedestal Column.
- Use Bolt (J) to fasten (D) to Pedestal Column.
- Use Allen Key (K) to drive (J). Do not tighten (J) completely until all four bolts are in place.

Step 4

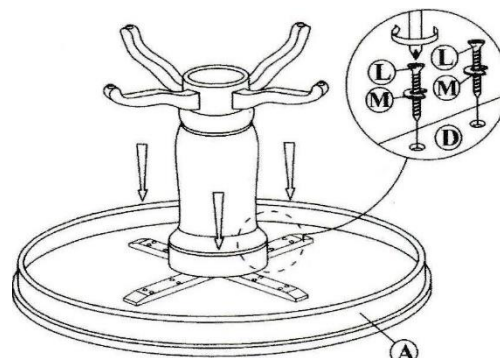

- Set Pedestal-Leg assembly bottom-side up on Table Top (A) from STEP 1.
- Align the screw holes on Mounting Rail to the marking on the bottom-side of (A).
- Use Screw (L) fitted with Flat Washer (M) to fasten (A) to Mounting Rail. Do not tighten (L) completely until all the screws are in place.
- With assistance, set the table right-side up. The assembly of the table is complete.