

# Assembly Instructions

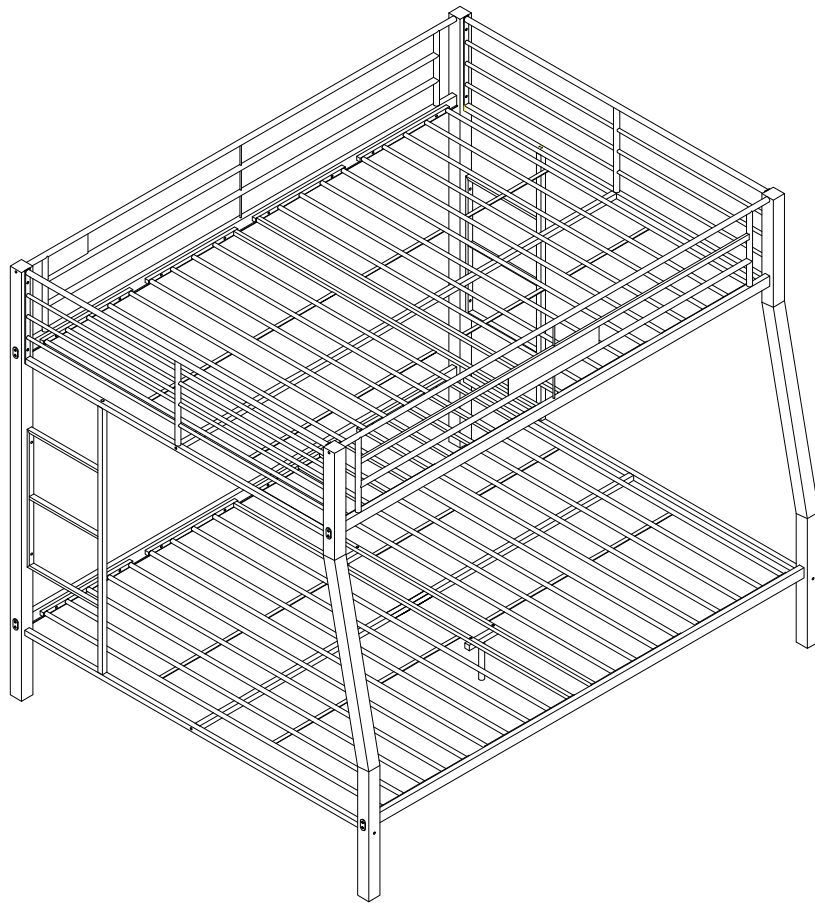

## ASSEMBLY RATING

The Assembly Rating is a 5-point system that shows the degree of effort needed in assembling a specific product (with 1 being easy and 5 being difficult). For some products, two persons are recommended.

## Tools Required For Assembly:

Allen Wrench

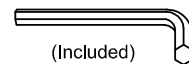

EASY



DIFFICULT



2 PERSONS RECOMMENDED

# ASSEMBLY & CARE ADVICE

FOR YOUR FURNITURE TO LAST, CORRECT ASSEMBLY AND PROPER MAINTENANCE ARE NECESSARY. PLEASE FOLLOW THE INFORMATION PROVIDED BELOW TO FULLY ENJOY YOUR FURNITURE.

## BASIC ASSEMBLY TECHNIQUES

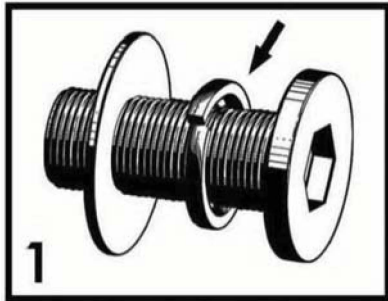

1  
When lock or spring washer is used in an assembly, please make sure the lock or spring washer is placed between the larger flat washer and the head of the screw or bolt.



2  
Position each part correctly and insert screws or bolts into their respective holes by hand tighten or using the proper hand tool. Only tighten when step is completed or when instructed to do so.

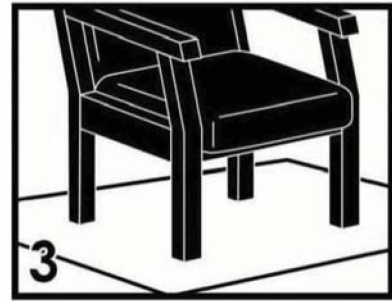

3  
Use cardboard or carpet area when assembling furniture to prevent scratches. Make sure the furniture rests on a flat and level surface with each leg evenly touching the floor.

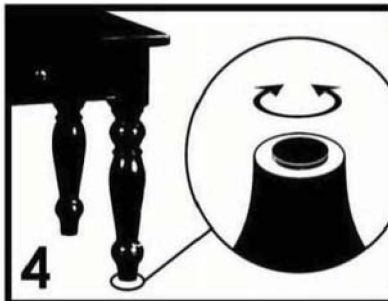

4  
Some furniture comes with height adjustment knobs underneath each leg. To lower or to raise each leg, you need to turn clockwise or counterclockwise, respectively.

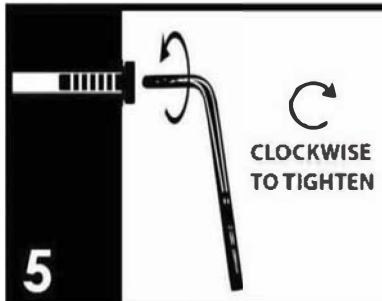

5  
Make sure all parts are properly aligned, then use the appropriate hand tool to completely tighten the bolts or screws. Do not use power tools and do not overtighten.

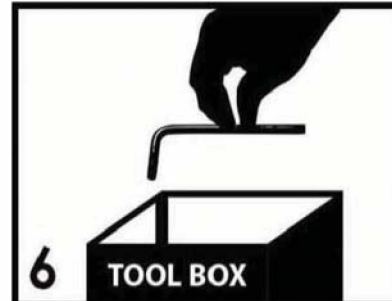

6  
Save the instructions and store the Allen wrench or any supplied tool for later maintenance. After two weeks, check and tighten any loose hardware and repeat again every six months thereafter.

IT IS THE USER'S RESPONSIBILITY TO MAINTAIN THE FURNITURE. THE HARDWARE MAY LOOSEN OVER TIME AND MAY CAUSE THE FURNITURE TO BE WOBBLY AND UNABLE TO SUPPORT ITS INTENDED WEIGHT CAPACITY. THIS MAY LEAD TO COLLAPSE AND MAY CAUSE SERIOUS INJURY.



**FAILURE TO FOLLOW THE GUIDELINES ABOVE MAY RESULT IN INJURY AND/OR PROPERTY DAMAGE.**



Before you begin, please read Page 2 of "Assembly and Care Advice".

And remember, do not tighten until each step is completed or instructed.

## Parts List



#1 x 2pcs  
HB Support Bar (Rear)



#2 x 2pcs  
HB Support Bar (Front)

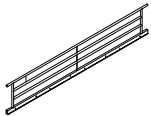

#3 x 1pc  
Rear Guardrail

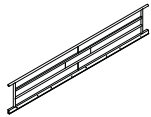

#4 x 1pc  
Front Guardrail

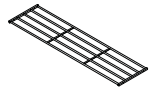

#5 x 2pcs  
Slat

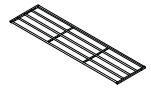

#6 x 2pcs  
Slat

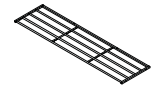

#7 x 2pcs  
Slat



#8 x 2pcs  
HB Connect Bar

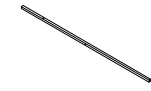

#9 x 2pcs  
HB Down Connect Bar



#10 x 2pcs  
Ladder

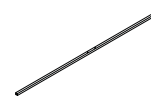

#11 x 2pcs  
Slat Support Bar

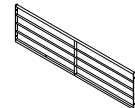

#12 x 2pcs  
Upper End Rail



#13 x 2pcs  
Upper Bed Slat



#14 x 2pcs  
Slat Support Leg



Before you begin, please read Page 2 of "Assembly and Care Advice".

And remember, do not tighten until each step is completed or instructed.

### Hardware List



#A x 8pcs  
Bolt 1/4" x 5/8"



#B x 36pcs  
Bolt 1/4" x 1"



#C x 8pcs  
Bolt 1/4" x 1-3/16"



#D x 8pcs  
Bolt 1/4" x 1-3/8"

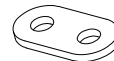

#E x 8pcs  
Spacer



#F x 8pcs  
Bolt 1/4" x 3"



#G x 16pcs  
Bolt 1/4" x 3"



#H x 1pc  
Allen Wrench



#1

#A x 8pcs  
#B x 4pcs  
#D x 4pcs  
#F x 4pcs

Align the top of (#10) to (#12) and the bottom to (#9), insert a bolt (#D) into each end and secure using the Allen wrench.

1-1

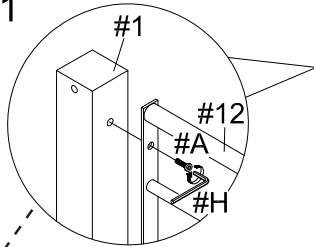

Align (#12) to (#1) and (#2), then insert 2 bolts (#A) into each side and secure using the Allen wrench.

1-3

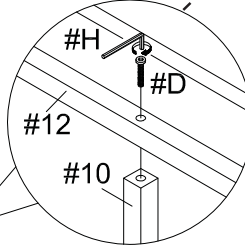

Align (#9) to (#1) and (#2), then insert a bolt (#F) into each end and secure using the Allen wrench (#H).

1-2

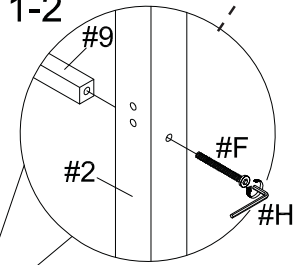

1-4

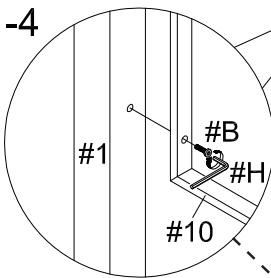

Align the sides of (#10) to (#1), insert 2 bolts (#B) and secure using the Allen wrench.

x 2



#2

#E x 8pcs  
#F x 4pcs  
#G x 16pcs

2-1

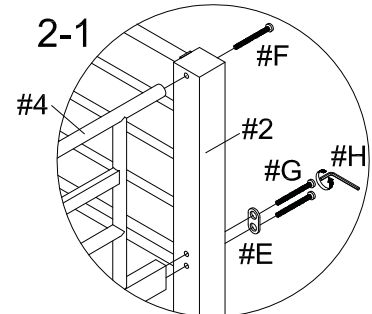

2-1. Align (#3) and (#4) to the top of (#1) and (#2). Insert a bolt (#F) to the top holes. Insert 2 bolts (#G) with a spacer (#E) into the bottom holes. Secure using the Allen wrench (#H).

2-2

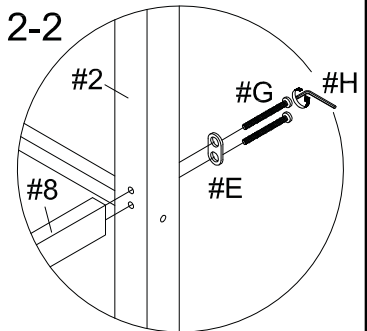

2-2. Align each end of (#8) to (#1) and (#2). Insert 2 bolts (#G) with a spacer (#E), then insert into each end and secure using the Allen wrench.



#3

#B x 32pcs

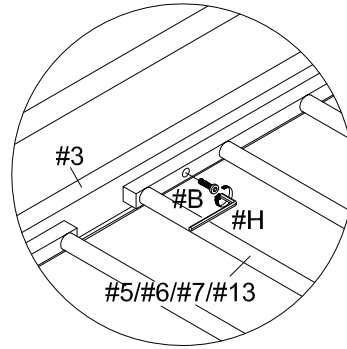
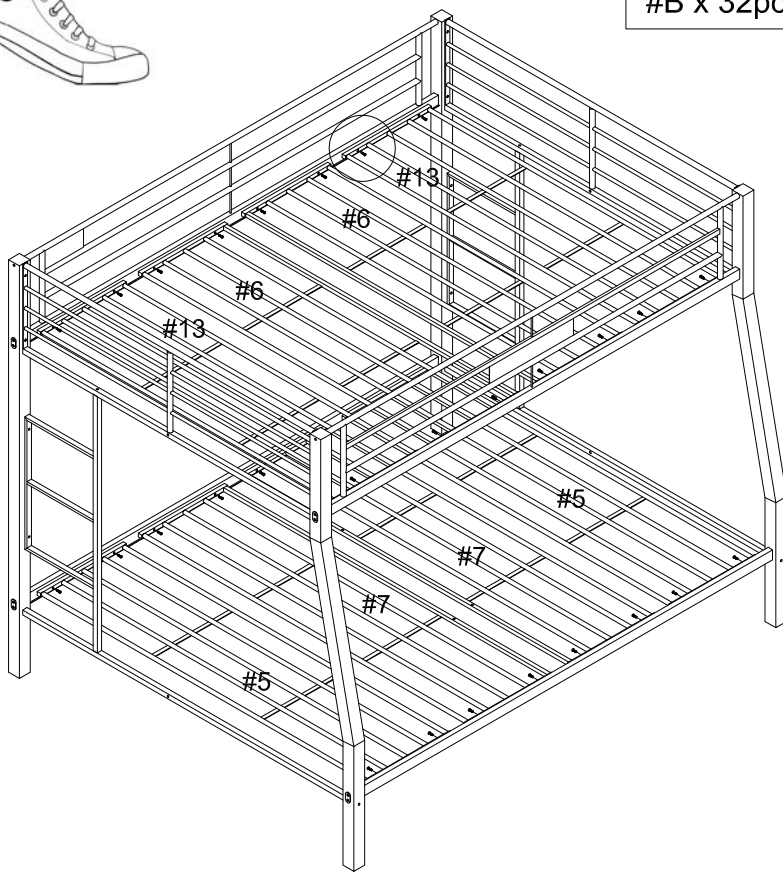

Align the slats according to the image on the left, and insert a bolt (#B) into each pre-drilled hole. Secure using the Allen wrench (#H).



#4

#C x 4pcs  
#D x 4pcs

4-1,4-2. Align each end of the support bar (#11) to the top and bottom beds, then insert a bolt (#D) into each end and secure using the Allen wrench (#H).

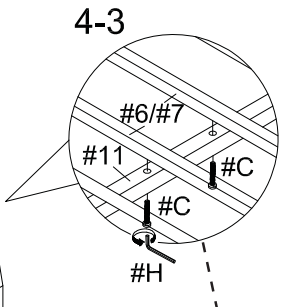
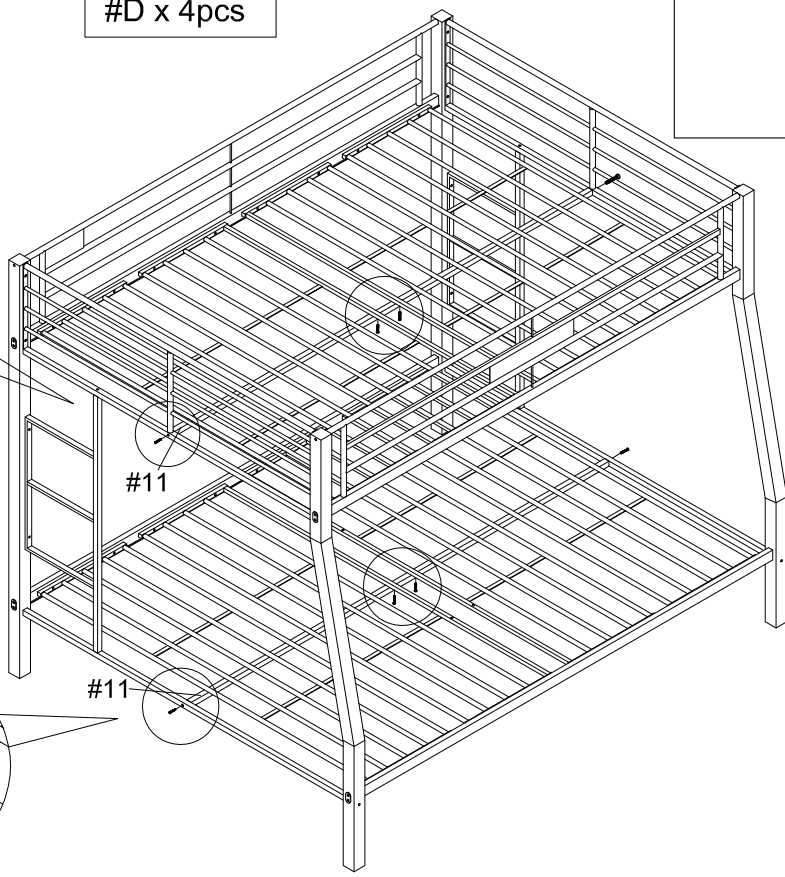
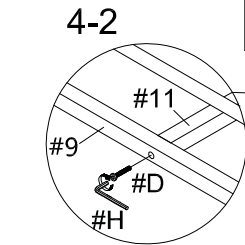
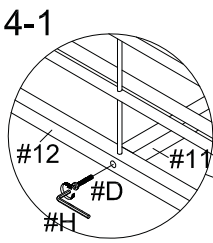

Insert 2 bolts (#C) into the center holes along the support bar (#11) and secure using the Allen wrench (#H).

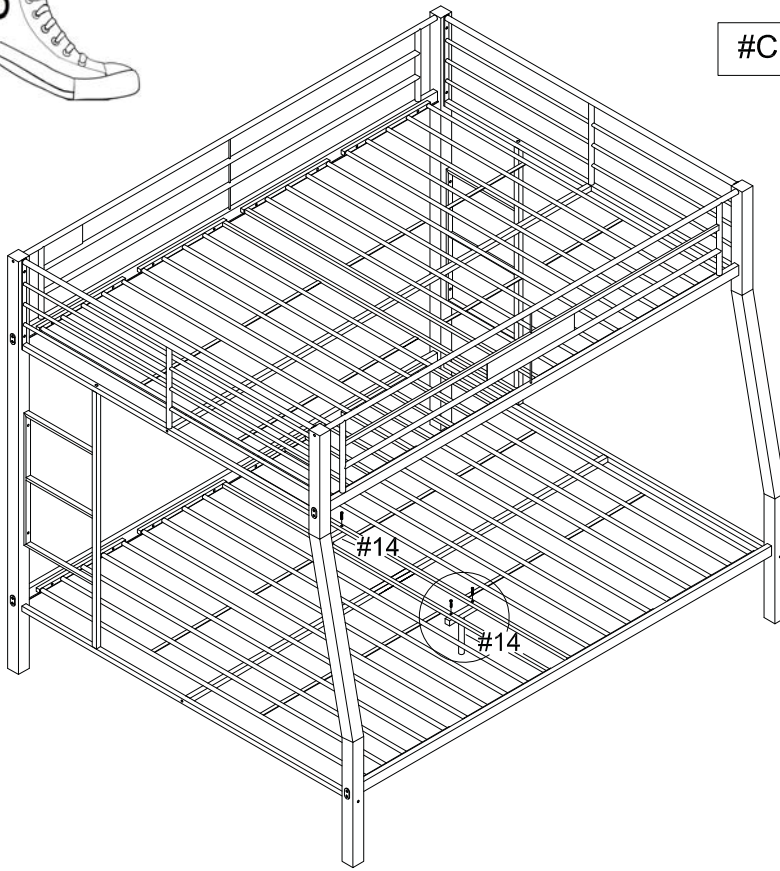

#C x 4pcs

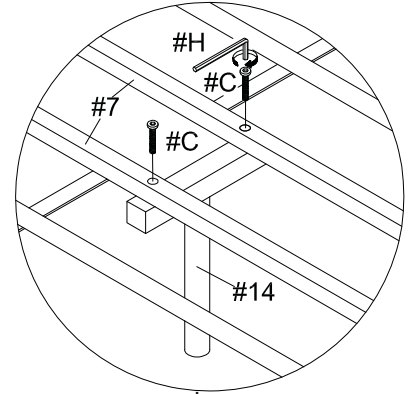

Align the slat support legs (#14) to the holes along the center of the bottom bed, then insert a bolt (#C) from the top and secure using the Allen wrench (#C).

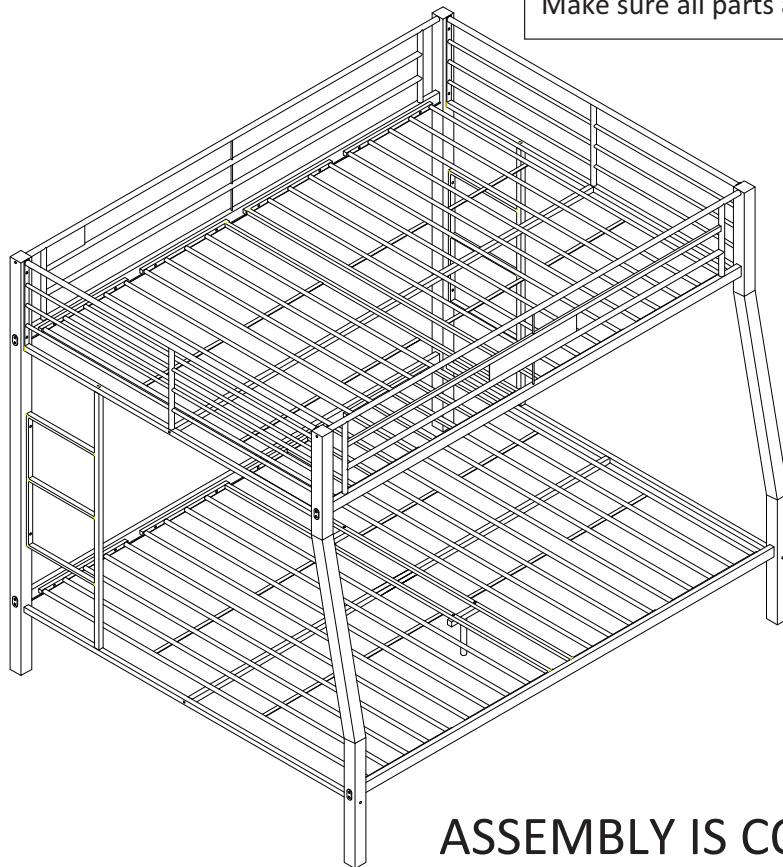

Make sure all parts are firmly secured.

ASSEMBLY IS COMPLETED