

# ASSEMBLY INSTRUCTIONS

INSTRUCTIONS DE MONTAGE

## TWIN/FULL BUNK BED WITH TRUNDLE

LIT SUPERPOSÉ SIMPLE/COMPLET AVEC LIT GIGOGNE

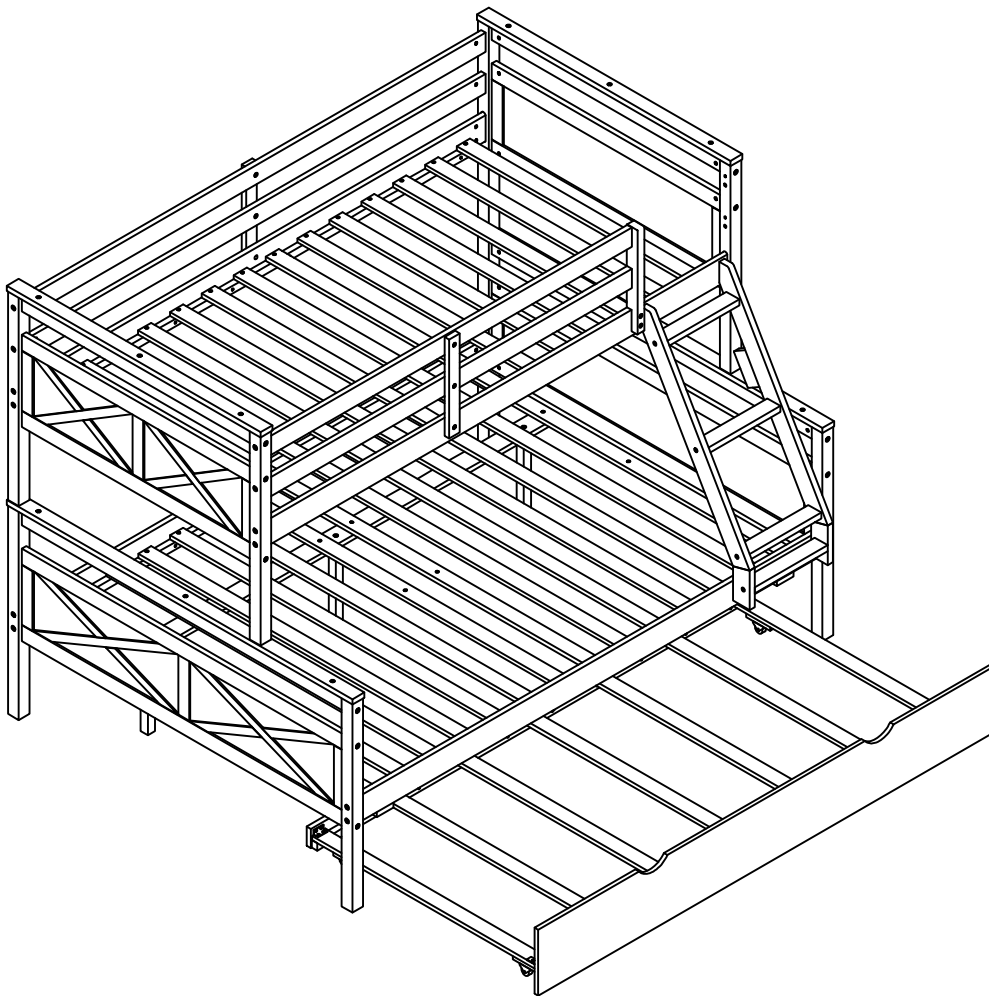

## SAFETY WARNINGS AND GENERAL NOTES:

Follow the information on the warnings on the bunk bed end structure and on the carton. Do not remove the warning label from the bed. Always use the recommended size mattress on mattress support, or both, to help prevent the likelihood of entrapment or falls.

The top surface of the mattress must be at least 5\*inch (127mm) below the upper edge of the guardrail.

Do not allow children under 6 years of age to use the upper bunk.

Periodically check and ensure the guardrail, ladder and other components are in their proper position, free from damage, and all connectors are tight.

Do not allow horseplay on or under beds.

Always prohibit jumping on the bed.

Prohibit more than one person on upper bunk.

Always use the ladder for entering and leaving the upper bunk.

Do not use substitute parts. Contact the manufacturer or dealer for replacement parts.

Use of a night-light may provide added safety precaution for a child using the upper bunk.

Always use guardrails on both long sides of the upper bunk.

If the bunk bed will be placed next to a wall, the guardrail that runs the full length of the bed should be placed against the wall to prevent entrapment between the bed and the wall.

The use of water or sleep flotation mattresses is prohibited.

**STRANGULATION HAZARD**-Never attach or hang items to any part of the bunk bed that are not designed for use with the bed.

Keep these instructions for future reference.

We recommend assembling your bunk bed on the shipping carton to protect your floor or carpet.

Be certain all staples are out of the box before beginning assembly on the shipping carton.

**THIS BED IS DESIGNED TO USE A TWIN MATTRESSES 38 1/2" WIDE X 74"-75" LONG WITH THE TOTAL THICKNESS NOT EXCEEDING 6" FOR UPPER BUNK, FOR THE LOWER FULL-SIZE SHOULD BE 54" WIDE X 74"-75" LONG, WIDE WITH 8" THICKNESS.**

**SURFACE OF MATTRESS MUST BE AT LEAST 5" (127MM) BELOW THE UPPER EDGE OF GUARDRAILS.**

## AVERTISSEMENTS DE SÉCURITÉ ET REMARQUES GÉNÉRALES :

Suivez les informations sur les avertissements figurant sur la structure d'extrémité du lit superposé et sur le carton. Ne retirez pas l'étiquette d'avertissement du lit. Utilisez toujours le matelas de taille recommandée sur le support de matelas, ou les deux, pour éviter tout risque de coincement ou de chute.

La surface supérieure du matelas doit être à au moins 5\*poûces (127 mm) sous le bord supérieur du garde-corps.

Ne laissez pas les enfants de moins de 6 ans utiliser le lit supérieur.

Vérifiez périodiquement et assurez-vous que le garde-corps, l'échelle et les autres composants sont dans leur bonne position, exempts de dommages et que tous les connecteurs sont bien serrés.

Ne permettez pas les chahuts sur ou sous les lits.

Interdisez toujours de sauter sur le lit.

Interdire plus d'une personne sur la couchette supérieure.

Utilisez toujours l'échelle pour entrer et sortir du lit supérieur.

N'utilisez pas de pièces de rechange. Contactez le fabricant ou le revendeur pour obtenir des pièces de rechange.

L'utilisation d'une veilleuse peut fournir une précaution supplémentaire en matière de sécurité pour un enfant utilisant le lit supérieur.

Utilisez toujours des garde-corps sur les deux côtés longs du lit supérieur.

Si le lit superposé doit être placé à côté d'un mur, le garde-corps qui s'étend sur toute la longueur du lit doit être placé contre le mur pour éviter tout coincement entre le lit et le mur.

L'utilisation de matelas flottants à eau ou de sommeil est interdite.

**RISQUE D'ÉTRANGULATION** - N'attachez ou ne suspendez jamais d'objets à une partie du lit superposé qui ne sont pas conçus pour être utilisés avec le lit.

Conservez ces instructions pour référence future.

Nous vous recommandons d'assembler votre lit superposé sur le carton d'expédition pour protéger votre sol ou votre tapis.

Assurez-vous que toutes les agrafes sont sorties de la boîte avant de commencer l'assemblage sur le carton d'expédition.

**CE LIT EST CONÇU POUR UTILISER UN MATELAS JUMELLES DE 38 1/2" DE LARGE X 74"-75" DE LONG AVEC L'ÉPAISSEUR TOTALE NE DÉPASSANT PAS 6" POUR LE COUCHE SUPÉRIEUR, POUR LA PLEINE TAILLE INFÉRIEURE DEVRAIT ÊTRE 54" DE LARGE X 74"-75 " LONG, LARGE AVEC 8" D'ÉPAISSEUR.**

**LA SURFACE DU MATELAS DOIT ÊTRE À AU MOINS 5" (127 MM) EN DESSOUS DU BORD SUPÉRIEUR DES GARDE-CORPS.**





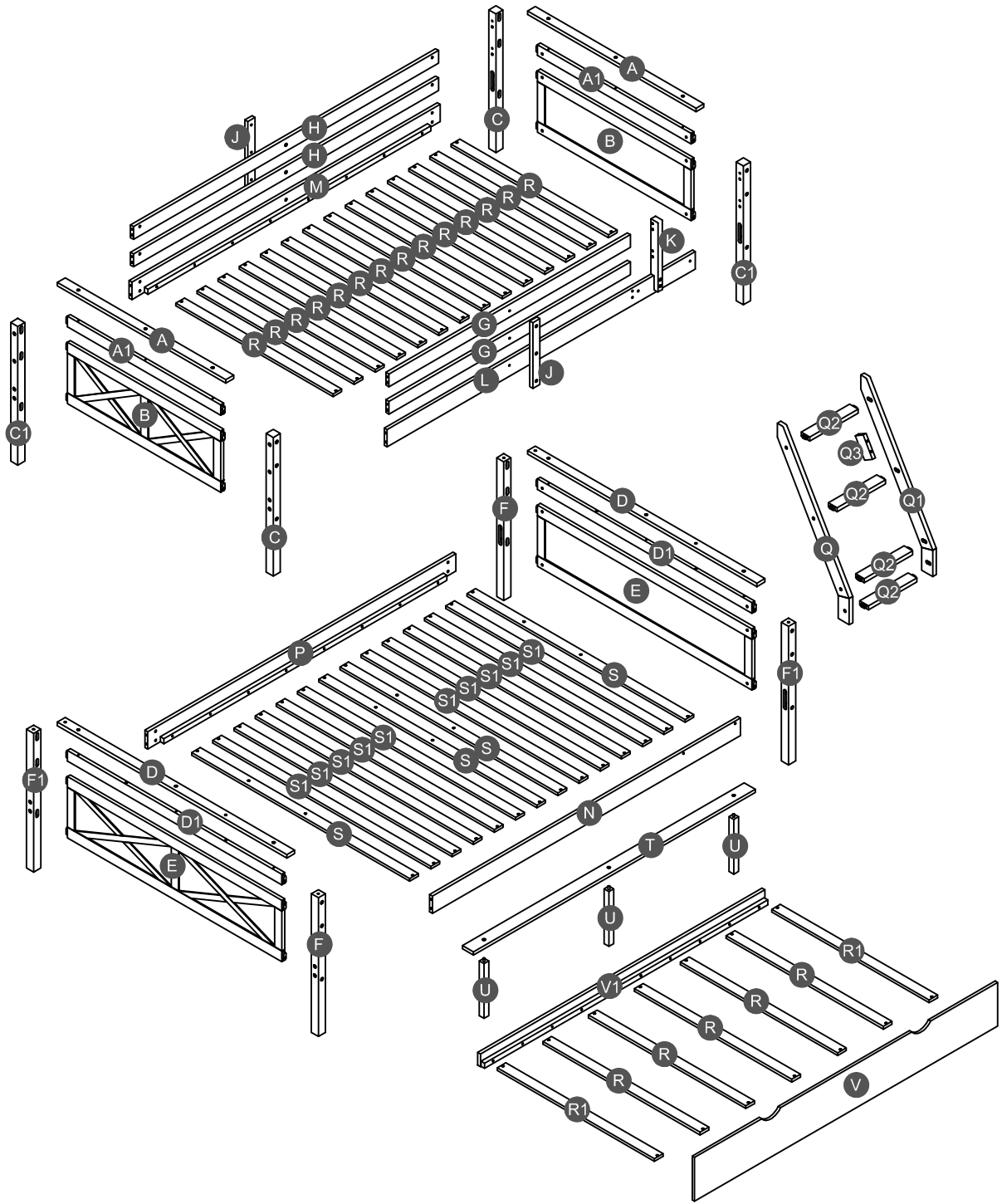





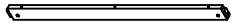

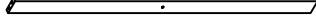
# Detail View

## Vue Détaillée

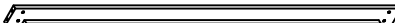

# Part List

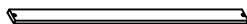
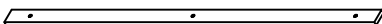







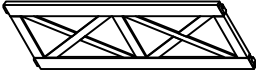
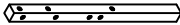
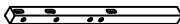

## Liste des Pièces

<p><b>A1</b></p>  <p>Upper horizontal bar - 2pcs Barre horizontale supérieure</p>	<p><b>D1</b></p>  <p>Lower horizontal bar - 2pcs Barre horizontale inférieure</p>	<p><b>G</b></p>  <p>Short guard rail (Front) - 2pcs Garde-corps court (Avant)</p>
<p><b>H</b></p>  <p>Long guard rail (Back) - 2pcs Garde-corps long (Arrière)</p>	<p><b>L</b></p>  <p>Upper side rail (Front) - 1pc Rail latéral supérieur (Avant)</p>	<p><b>M</b></p>  <p>Upper side rail (Back) - 1pc Rail latéral supérieur (Arrière)</p>
<p><b>N</b></p>  <p>Lower side rail (Front) - 1pc Rail latéral inférieur (Avant)</p>	<p><b>P</b></p>  <p>Lower side rail (Back) - 1pc Rail latéral inférieur (Arrière)</p>	<p><b>Q</b></p>  <p>Ladder (left) - 1pc Échelle (gauche)</p>
<p><b>Q1</b></p>  <p>Ladder (right) - 1pc Échelle (droite)</p>	<p><b>Q3</b></p>  <p>Support - 1pc Soutien</p>	<p><b>R</b></p>  <p>Slats - 14pcs Lattes</p>
<p><b>T</b></p>  <p>Lower support slat - 1pc Lattes de support inférieure</p>	<p><b>V</b></p>  <p>Front panel of Trundle - 1pc Panneau avant du Trundle</p>	<p><b>V1</b></p>  <p>Back panel side rail of Trundle - 1pc Rail latéral du panneau arrière du Trundle</p>

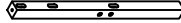
# Part List

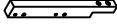

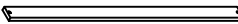
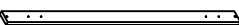

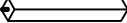





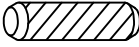



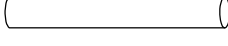

Liste des Pièces

Hardware inside / Matériel à l'intérieur

<p><b>A</b></p>  <p>Cap for upper HB/FB - 2pcs Capuchon pour HB/FB supérieur</p>	<p><b>B</b></p>  <p>Upper frame HB/FB - 2pcs Cadre supérieur HB/FB</p>	<p><b>C</b></p>  <p>Upper leg (Left Front /Right Back) - 2pcs Pied supérieur (Avant gauche/arrière droit)</p>
<p><b>C1</b></p>  <p>Upper leg (Left Back /Right Front) - 2pcs Pied supérieur (Arrière gauche/Avant droit)</p>	<p><b>D</b></p>  <p>Cap for upper HB/FB - 2pcs Capuchon pour HB/FB supérieur</p>	<p><b>E</b></p>  <p>Lower frame HB/FB - 2pcs Châssis inférieur HB/FB</p>
<p><b>F</b></p>  <p>Lower leg (Left Front /Right Back) - 2pcs Pied inférieur (Avant gauche/arrière droit)</p>	<p><b>F1</b></p>  <p>Lower leg (Left Back /Right Front) - 2pcs Pied inférieur (Arrière gauche/Avant droit)</p>	<p><b>J</b></p>  <p>Vertical guard rail - 2pcs Garde-corps vertical</p>
<p><b>K</b></p>  <p>Vertical guard rail (Right) - 1pc Garde-corps vertical (Droite)</p>	<p><b>Q2</b></p>  <p>Step ladder - 4pcs Escabeau</p>	<p><b>R</b></p>  <p>Slats - 5pcs Latte</p>
<p><b>R1</b></p>  <p>Latte - 2pcs Latte</p>	<p><b>S</b></p>  <p>Slats - 4pcs Latte</p>	<p><b>S1</b></p>  <p>Slats - 10pcs Latte</p>
<p><b>U</b></p>  <p>Leg support - 3pcs Support pied</p>		

# Hardware List

## Liste des Accessoires

<b>1</b>  Ø10*40mm	<b>2</b>  (Ø15)1/4"*100mm	<b>3</b>  (Ø15)1/4"*80mm
Wood dowel (8pcs) Cheville en bois	Hex-Head bolts (22pcs) Boulons à tête hexagonale	Hex-Head bolts (28pcs) Boulons à tête hexagonale
<b>4</b>  (Ø12)1/4"*60mm	<b>5</b>  (Ø12)1/4"*40mm	<b>6</b>  (Ø12)1/4"*35mm
Hex-Head bolts (8pcs) Boulons à tête hexagonale	Hex-Head bolts (4pcs) Boulons à tête hexagonale	Hex-Head bolts (2pcs) Boulons à tête hexagonale
<b>7</b>  (Ø12)1/4"*30mm	<b>8</b>  1/4"*15 (9.5mm)	<b>9</b>  Ø9*90mm
Hex-Head bolts (6pcs) Boulons à tête hexagonale	Horizontal-Hole bolts(56pcs) Boulons à tête hexagonale	Connecting bar (4pcs) Barre de connexion
<b>10</b>  (Ø12)1/4"*40mm	<b>11</b>  Ø4*30mm	<b>12</b>  Ø3.5*15mm
Hex-Head bolts (12pcs) Boulons à tête hexagonale	Wood screws (86pcs) Vis	Wood screws (16pcs) Vis
<b>13</b>  95*95*18*3mm	<b>14</b>  40*17*17*1.6mm	<b>15</b>  70*35*19 mm
Metal bracket (2pcs) Support métallique	Metal bracket (2pcs) Support métallique	Trundle stopper (2pcs) Bouchon pour lit gigogne
<b>16</b>  100*61*20mm	<b>17</b>  (1/4")4.5*58mm	
Wheels (4pcs) Roues	Allen key (1pc) Clé Allen	

### ASSEMBLY TOOLS REQUIRED ( NOT INCLUDED )

OUTILS D'ASSEMBLAGE REQUIS (NON INCLUS)

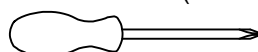

( Phillip head screwdriver )





PLEASE BE CAREFUL DO NOT DAMAGE THE HOLE POSITION WHEN YOU USE POWER TOOLS !

NE PAS UTILISER DES OUTILS ÉLECTRIQUES POUR ASSEMBLER CE PRODUIT !

# STEP 1:

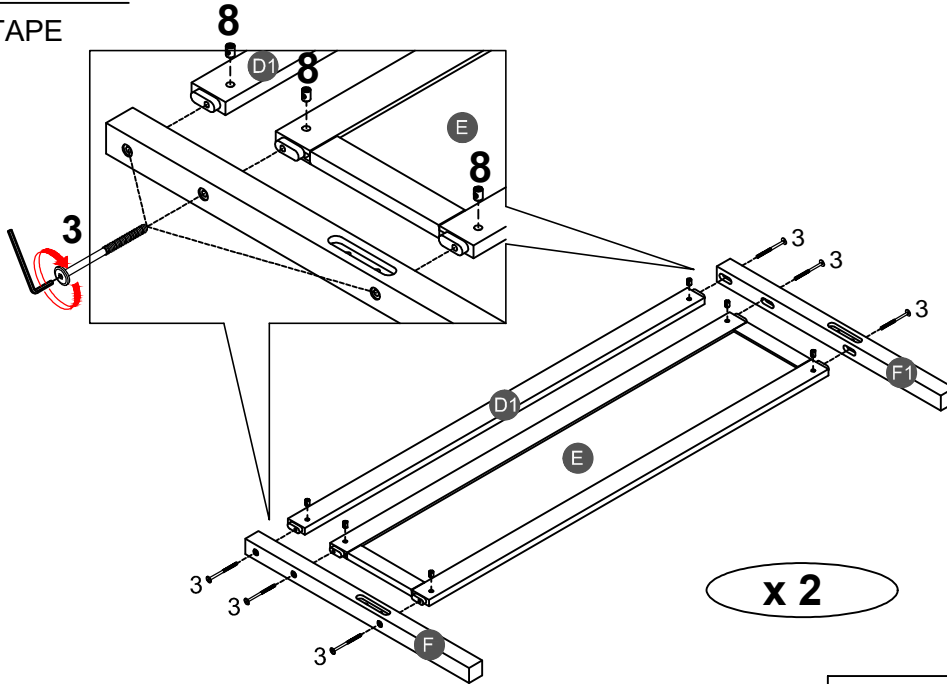
ÉTAPE



<b>3</b>		<b>8</b>	
<b>12PCS</b>		<b>12PCS</b>	

Note: Part 8 will face up with the "x" mark on it, otherwise it cannot be tightened

Remarque: La pièce 8 sera face vers le haut avec la marque "x", sinon elle ne peut pas être serrée.

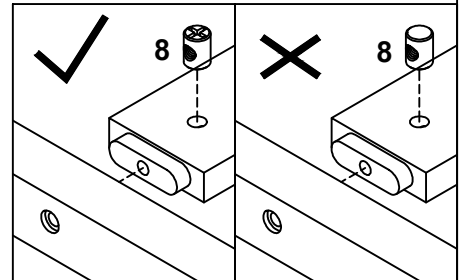

# STEP 2:

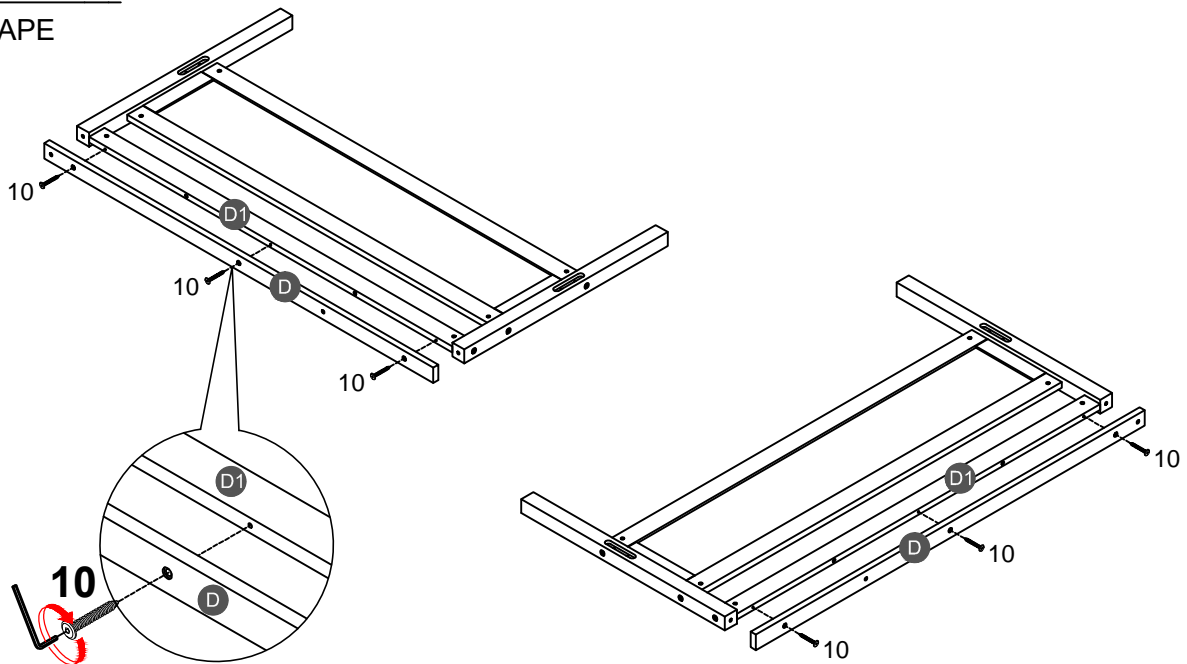

ÉTAPE



<b>10</b>	
<b>6PCS</b>	

### STEP 3:

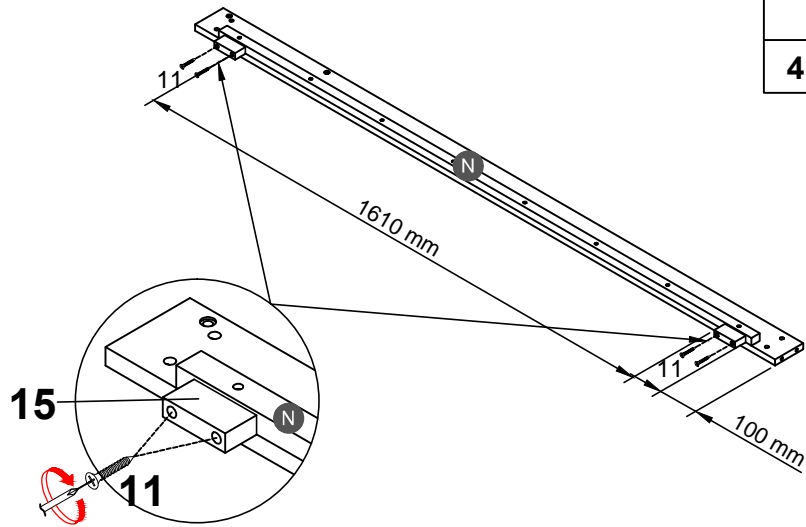

ÉTAPE

<b>11</b> 	<b>15</b> 
<b>4PCS</b>	<b>2PCS</b>



### STEP 4:

ÉTAPE

<b>2</b> 	<b>8</b> 
<b>8PCS</b>	<b>8PCS</b>

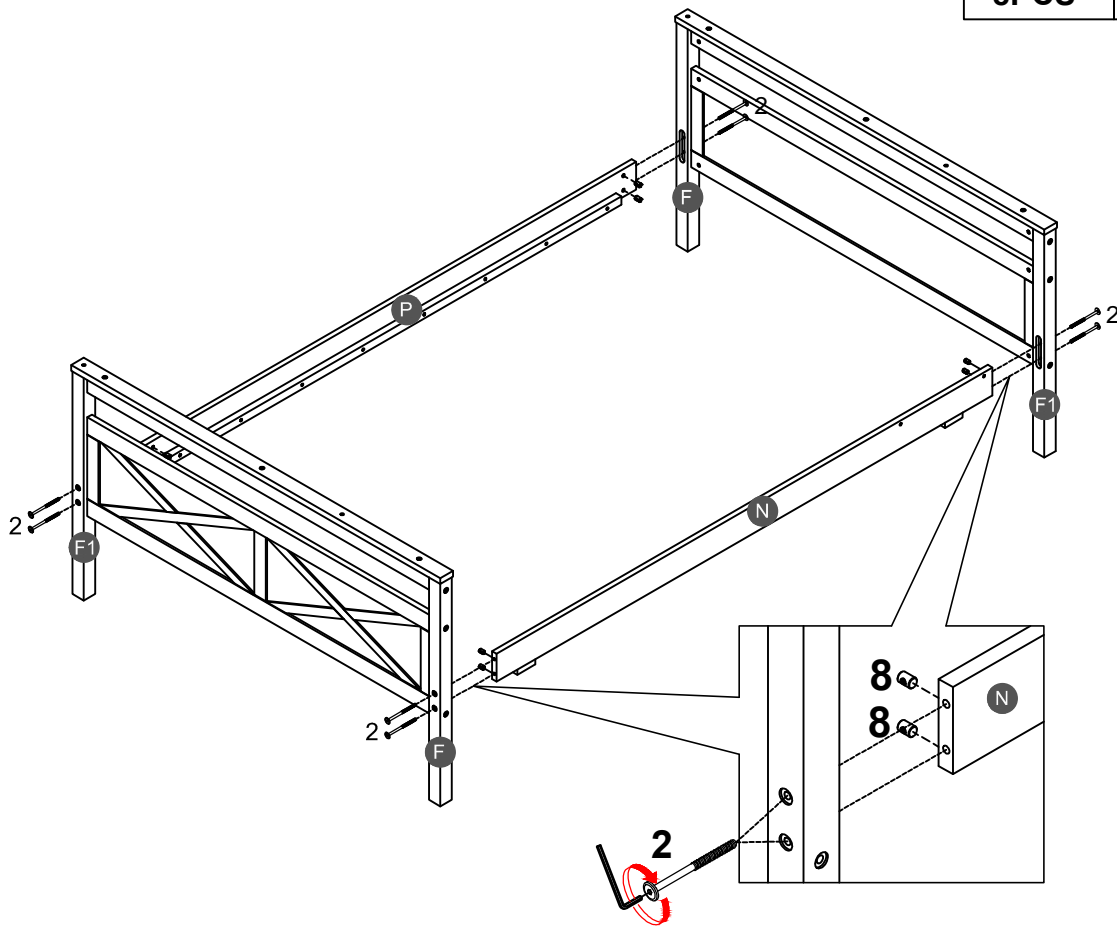

## STEP 5:

ÉTAPE

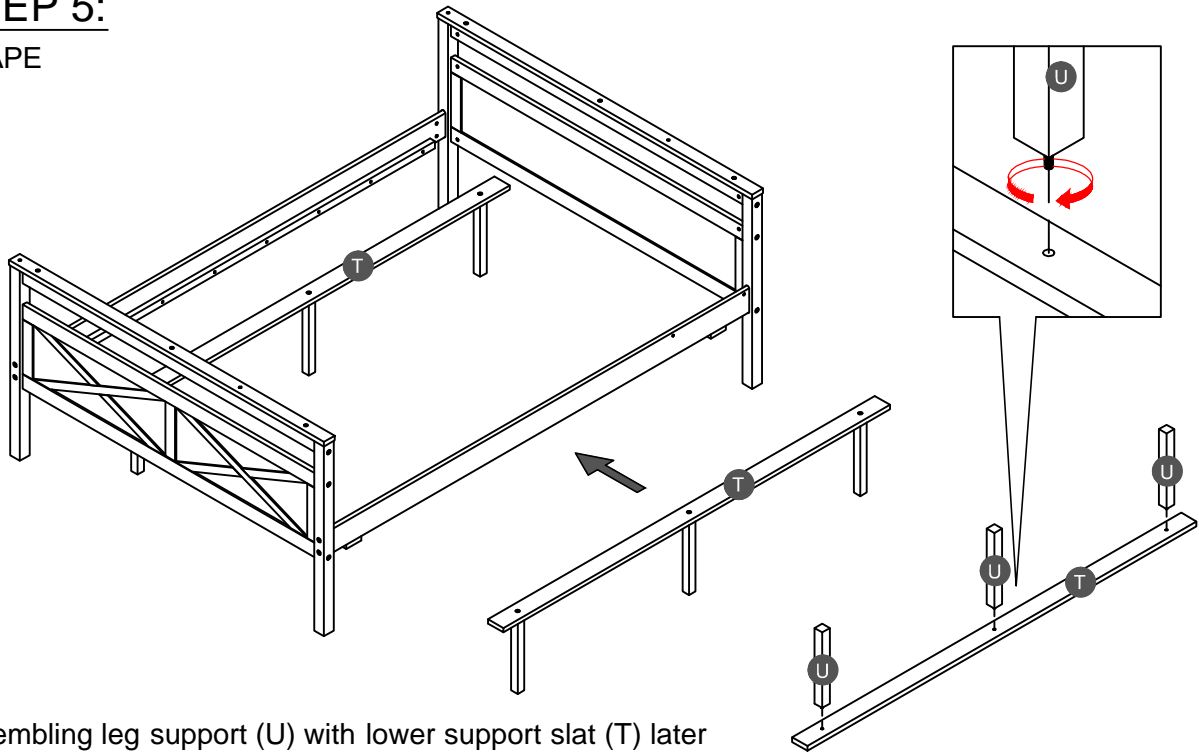

Assembling leg support (U) with lower support slat (T) later rotate, Move support slat inside Full bed.

Assemblage du support de jambe (U) avec la latte de support inférieure (T) puis faites pivoter la latte de support à l'intérieur du lit double.

## STEP 6:

ÉTAPE

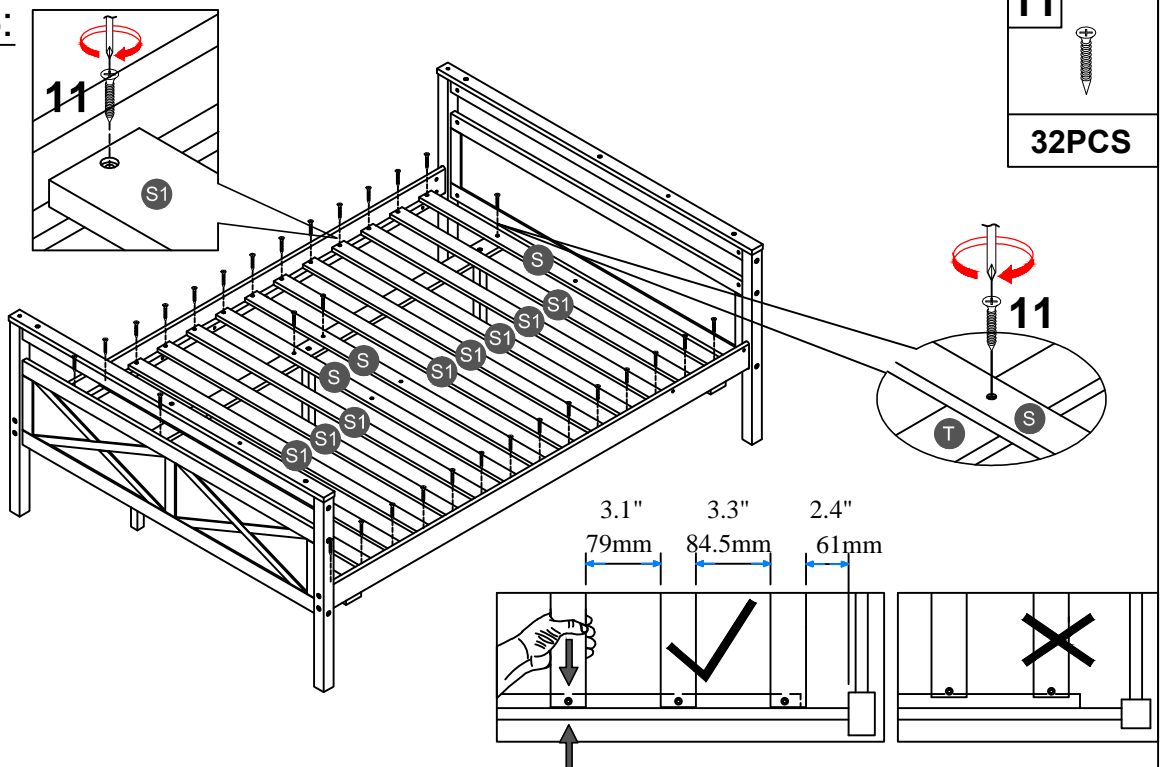

11



32PCS



**NOTE:** Please make sure the bed slats close to the side rail before locking the screws to avoid breakage. This step is required for both the left and right sides. Moreover, please do not lock the screws of the bed slats at the outermost edge to avoid damaging.

**Remarque:** Assurez-vous Les lattes du lit fermer du rail latéral avant de verrouiller les vis pour éviter la casse. Cette étape est requise pour tous les deux côtés gauche et droit. De plus, ne verrouillez pas les vis des lattes de lit sur le bord le plus extérieur pour éviter d'endommager.

# STEP 7:

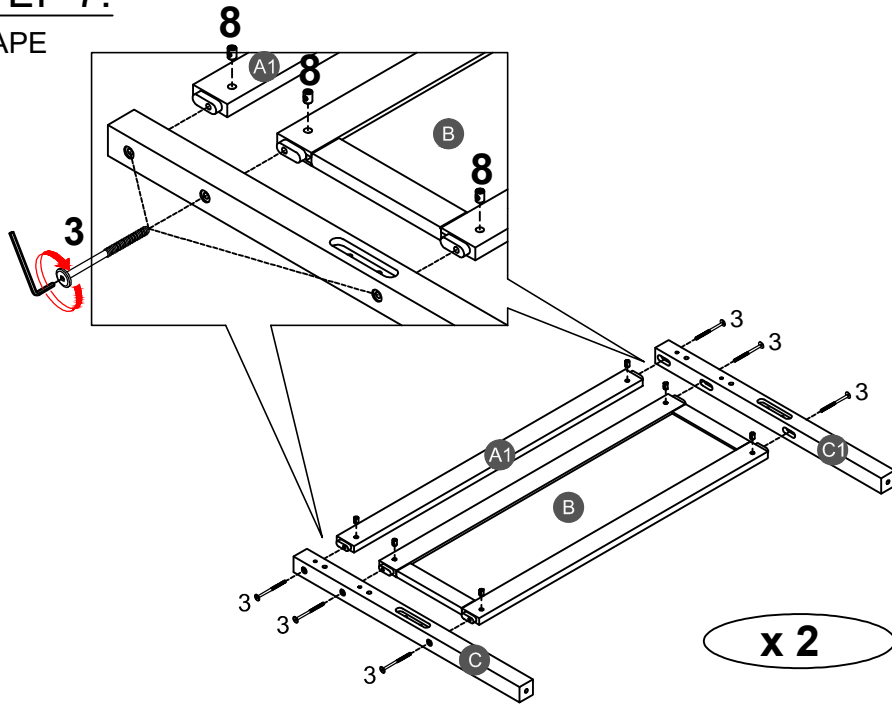
ÉTAPE



<b>3</b>		<b>8</b>	
<b>12PCS</b>		<b>12PCS</b>	

Note: Part 8 will face up with the "x" mark on it, otherwise it cannot be tightened

Remarque: La pièce 8 sera face vers le haut avec la marque "x", sinon elle ne peut pas être serrée.

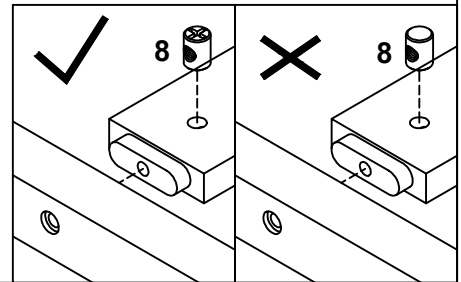

# STEP 8:

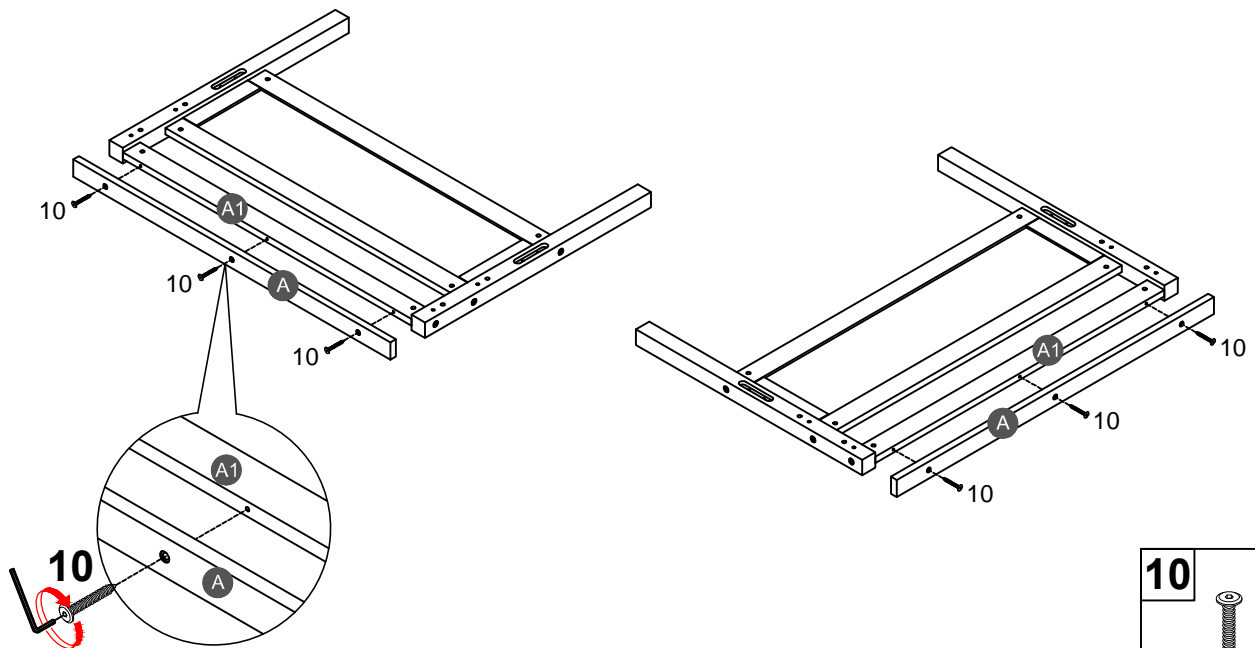

ÉTAPE

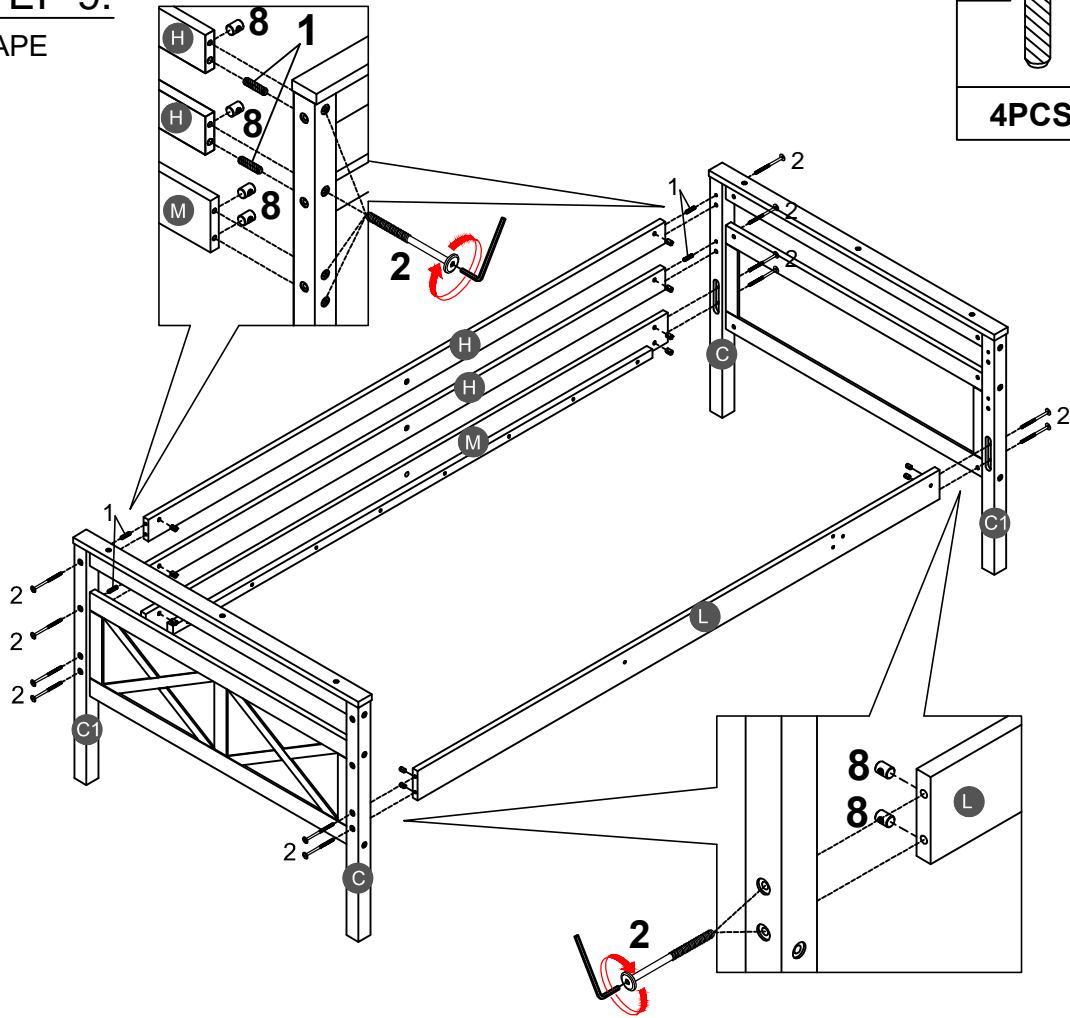

<b>10</b>	
<b>6PCS</b>	

**STEP 9:**  
ÉTAPE



<b>1</b>		<b>2</b>	
<b>4PCS</b>		<b>12PCS</b>	
		<b>8</b>	
		<b>12PCS</b>	



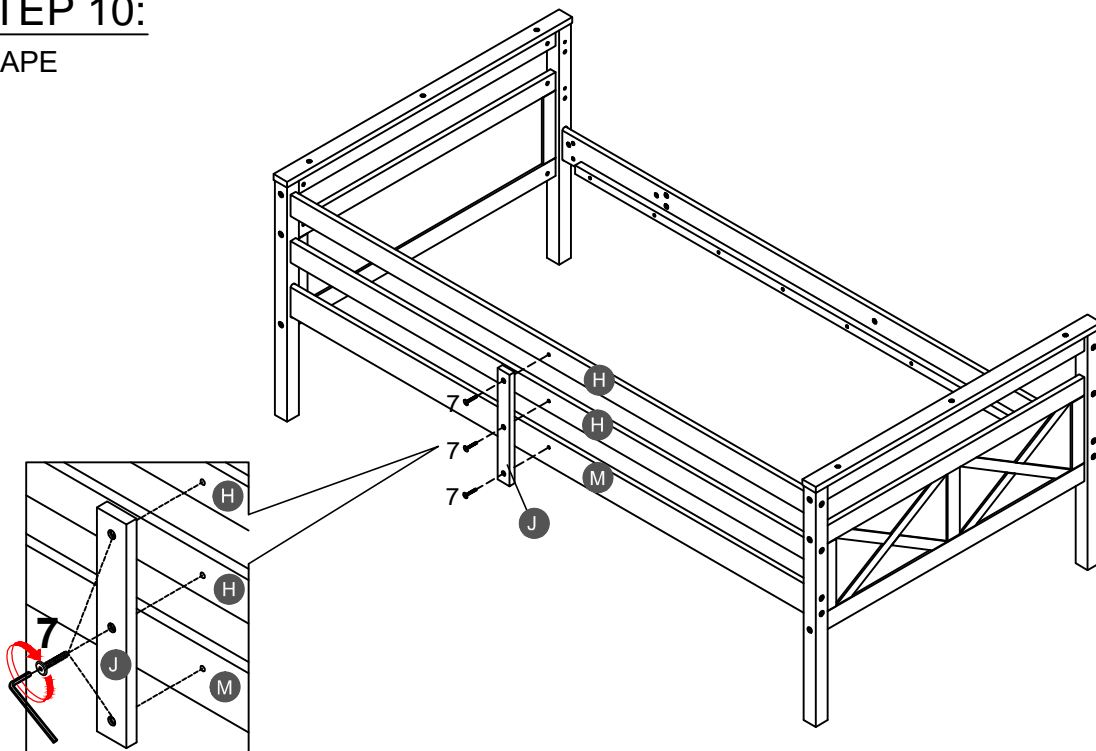

**STEP 10:**  
ÉTAPE



<b>7</b>	
<b>3PCS</b>	

# STEP 11:

ÉTAPE

<b>1</b>		<b>2</b>		<b>3</b>	
<b>4PCS</b>		<b>2PCS</b>		<b>2PCS</b>	
			<b>6</b>		
			<b>2PCS</b>		
			<b>8</b>		
			<b>4PCS</b>		

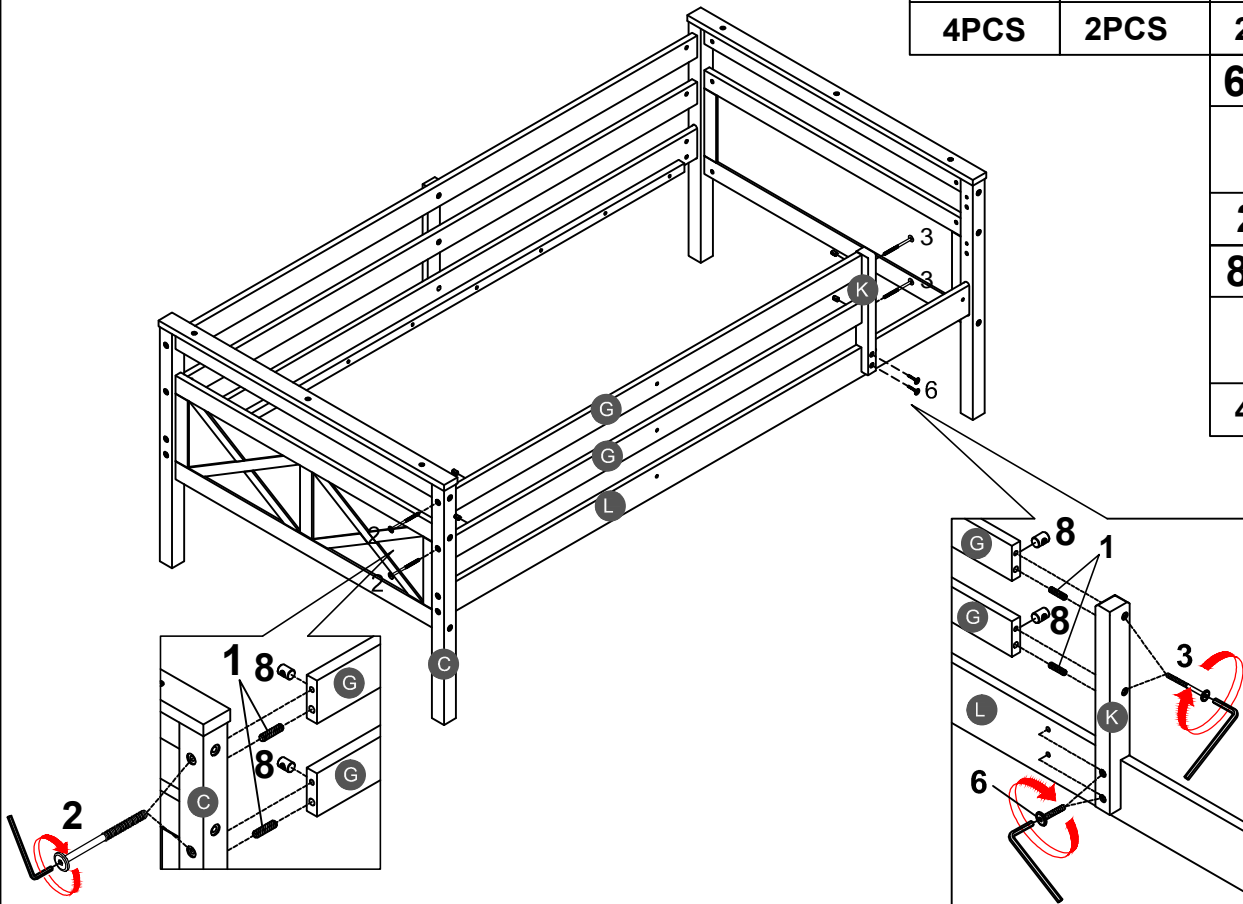

# STEP 12:

ÉTAPE

<b>7</b>	
<b>3PCS</b>	

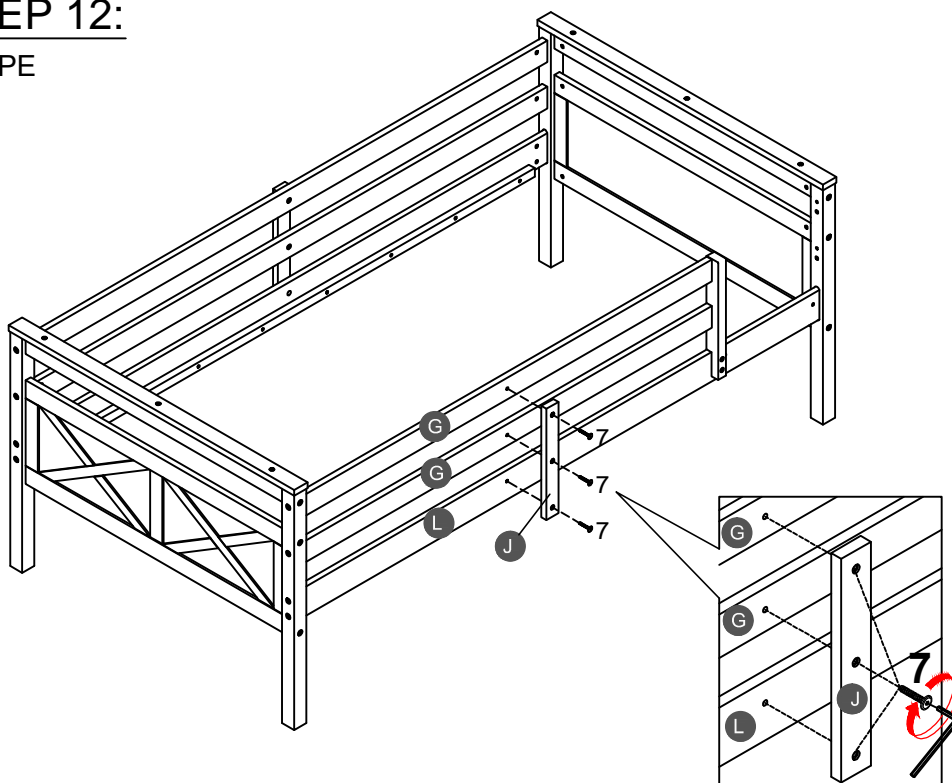

# STEP 13:

ÉTAPE

11



28PCS

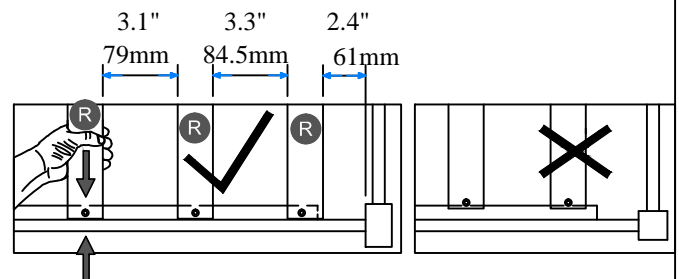
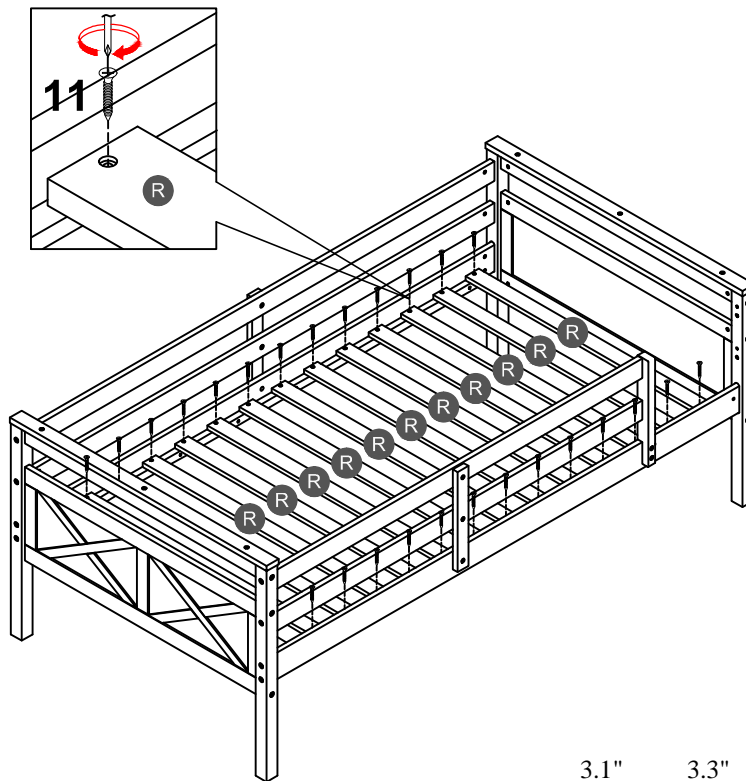

**NOTE:** Please make sure the bed slats close to the side rail before locking the screws to avoid breakage. This step is required for both the left and right sides. Moreover, please do not lock the screws of the bed slats at the outermost edge to avoid damaging.

**Remarque:** Assurez-vous Les lattes du lit fermer du rail latéral avant de verrouiller les vis pour éviter la casse. Cette étape est requise pour tous les deux côtés gauche et droit. De plus, ne verrouillez pas les vis des lattes de lit sur le bord le plus extérieur pour éviter d'endommager.

**STEP 14:**  
ÉTAPE

**9**   
**4PCS**

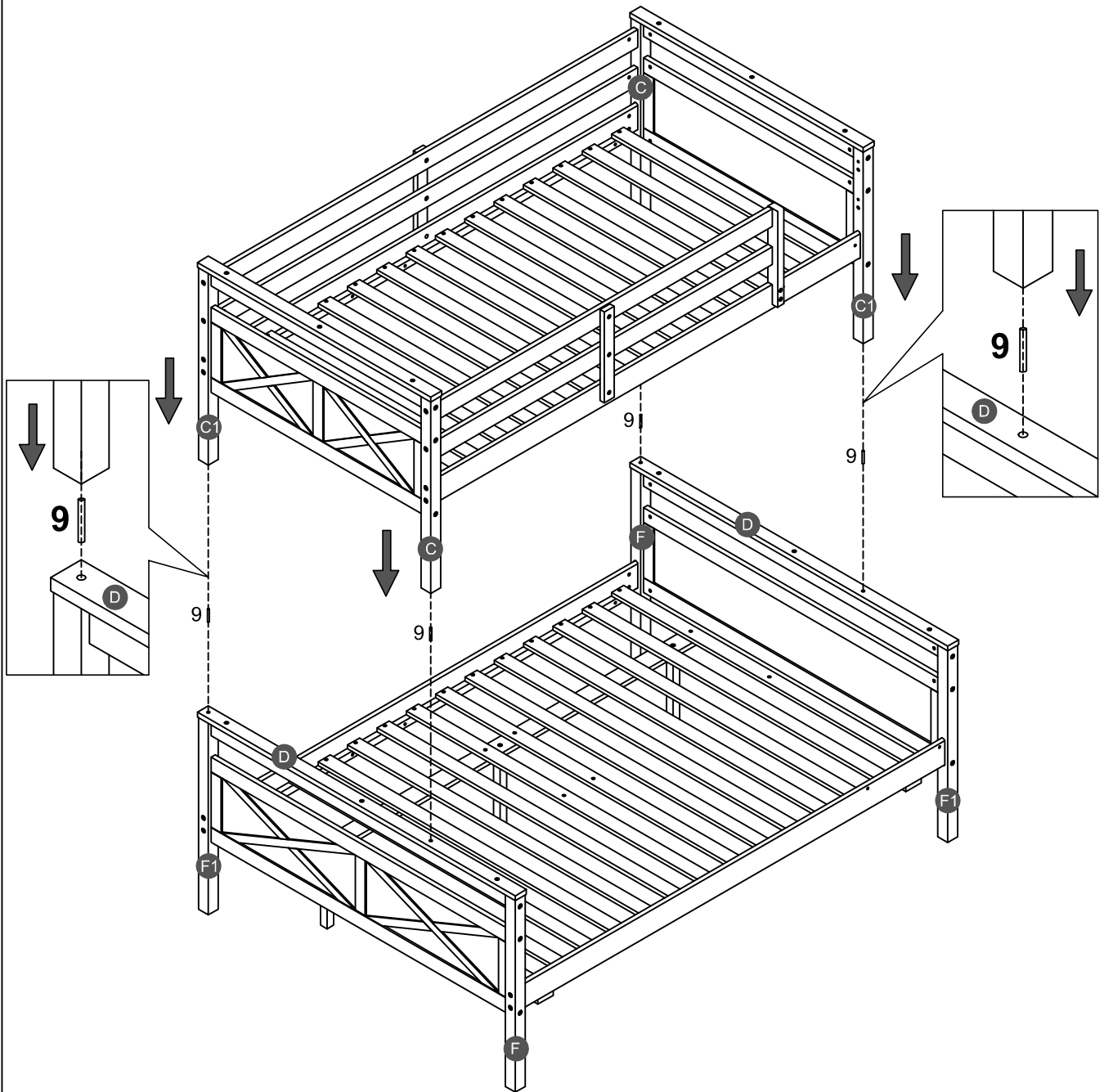

# STEP 15:

ÉTAPE

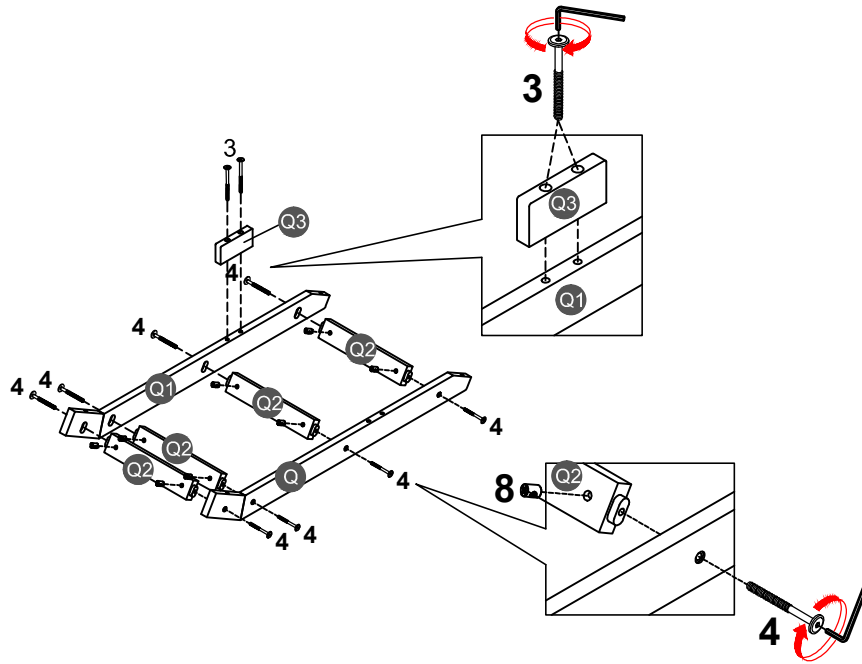

3



2PCS

4



8PCS

8



8PCS

# STEP 16:

ÉTAPE

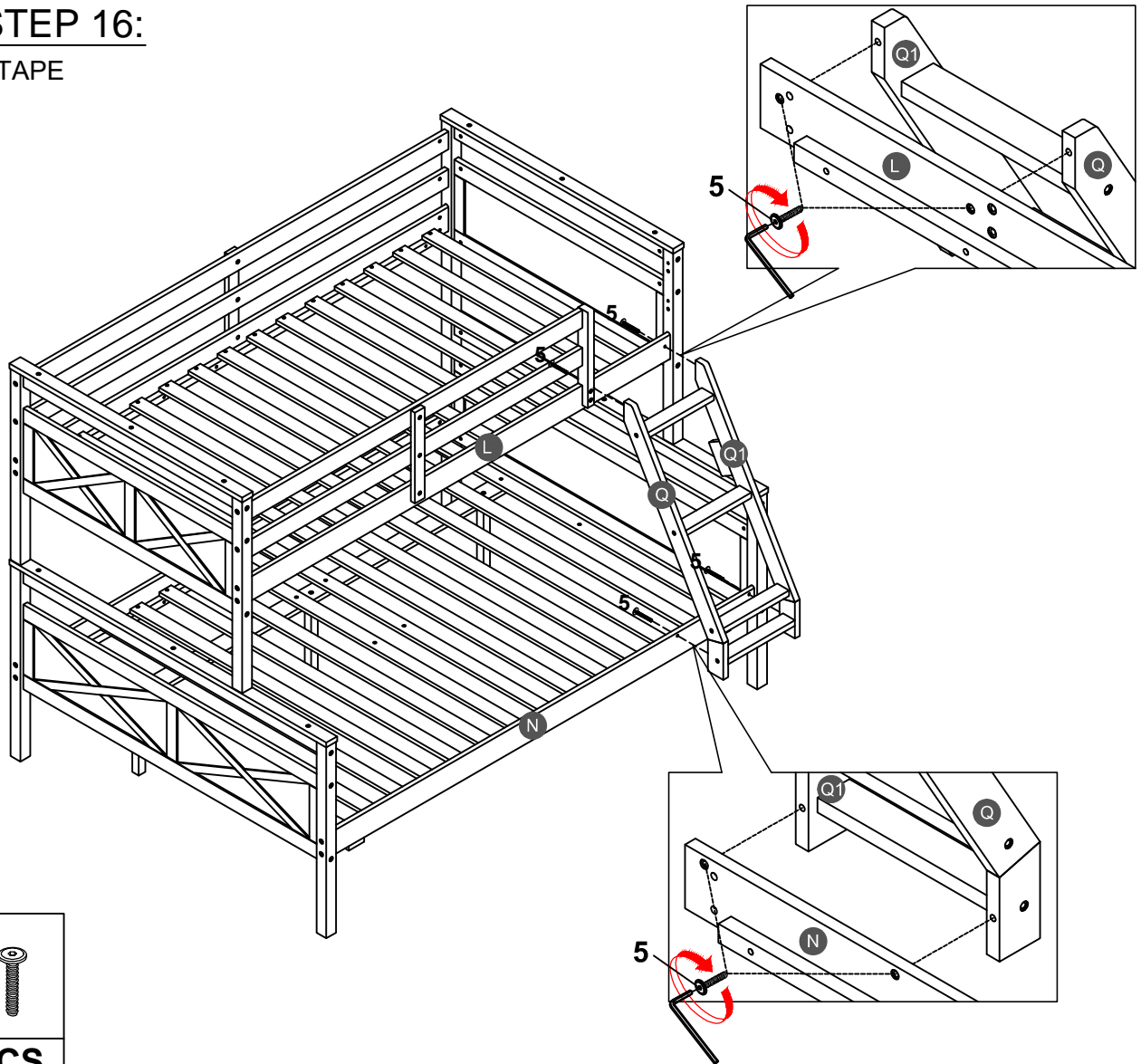

5





4PCS

## STEP 17:

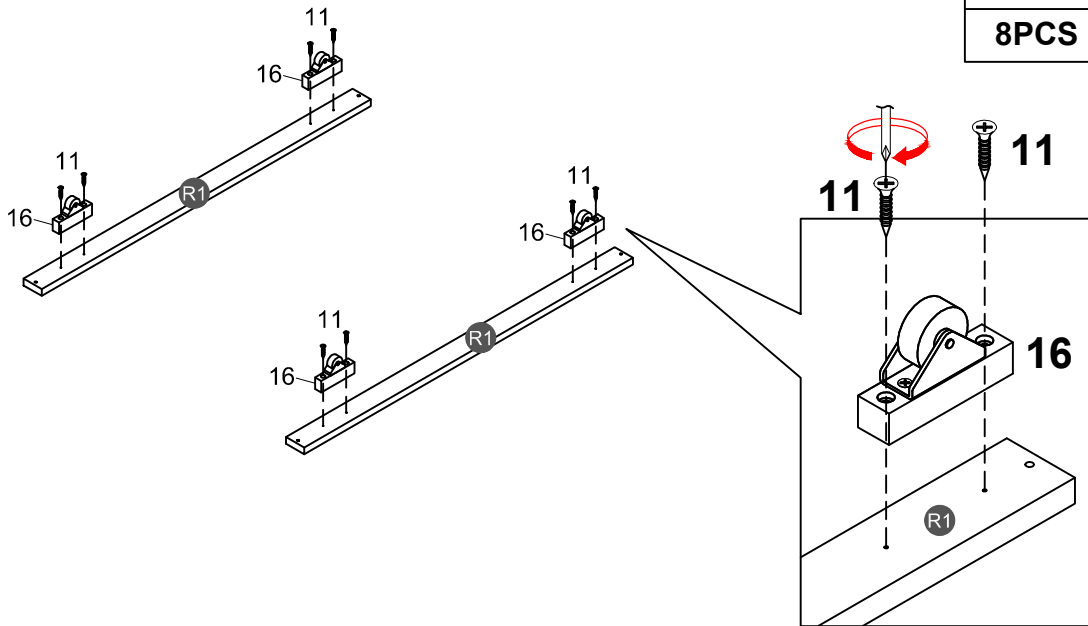
ÉTAPE



<b>11</b> 	<b>16</b> 
<b>8PCS</b>	<b>4PCS</b>

## STEP 18:

ÉTAPE

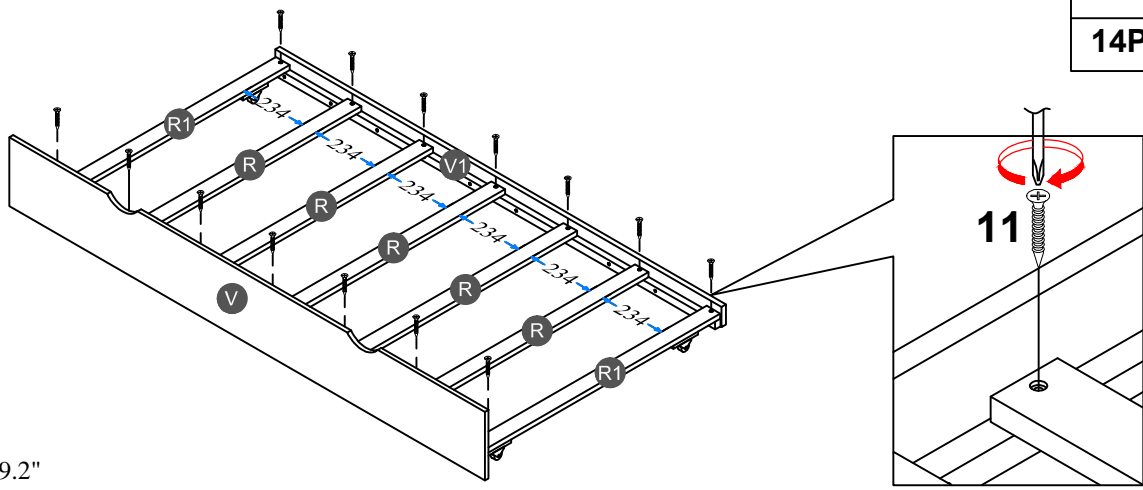

<b>11</b> 
<b>14PCS</b>

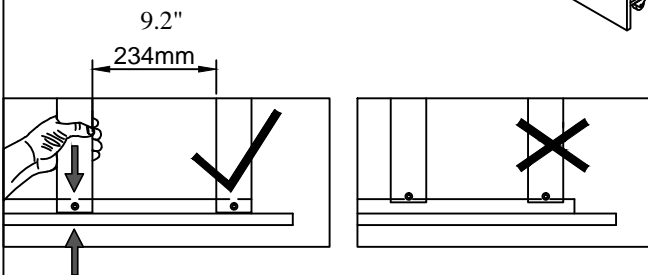



**NOTE:** Please make sure the bed slats close to the side rail before locking the screws to avoid breakage. This step is required for both the left and right sides. Moreover, please do not lock the screws of the bed slats at the outermost edge to avoid damaging.

**Remarque:** Assurez-vous Les lattes du lit fermer du rail latéral avant de verrouiller les vis pour éviter la casse. Cette étape est requise pour tous les deux côtés gauche et droit. De plus, ne verrouillez pas les vis des lattes de lit sur le bord le plus extérieur pour éviter d'endommager.

# STEP 19:

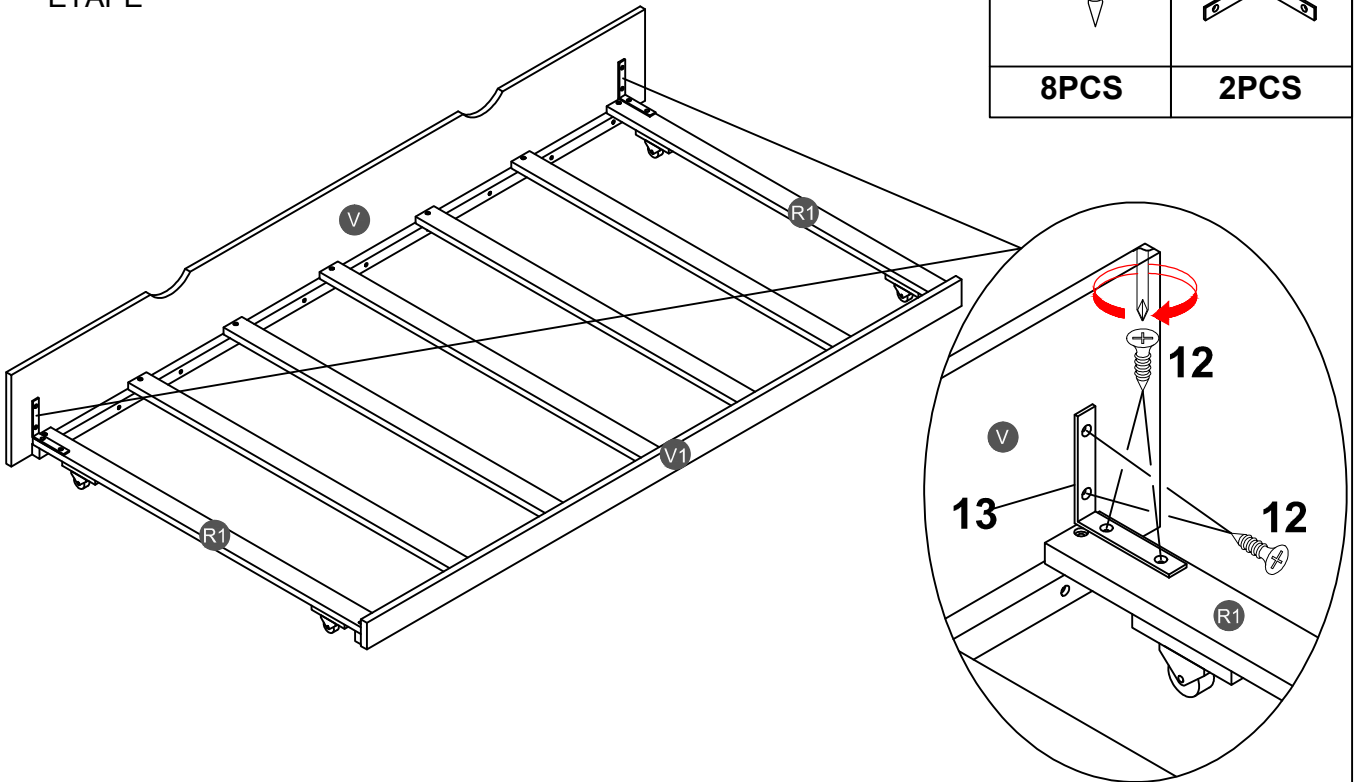

ÉTAPE

<b>12</b> 	<b>13</b> 
<b>8PCS</b>	<b>2PCS</b>



# STEP 20:

ÉTAPE

<b>12</b> 	<b>14</b> 
<b>8PCS</b>	<b>2PCS</b>

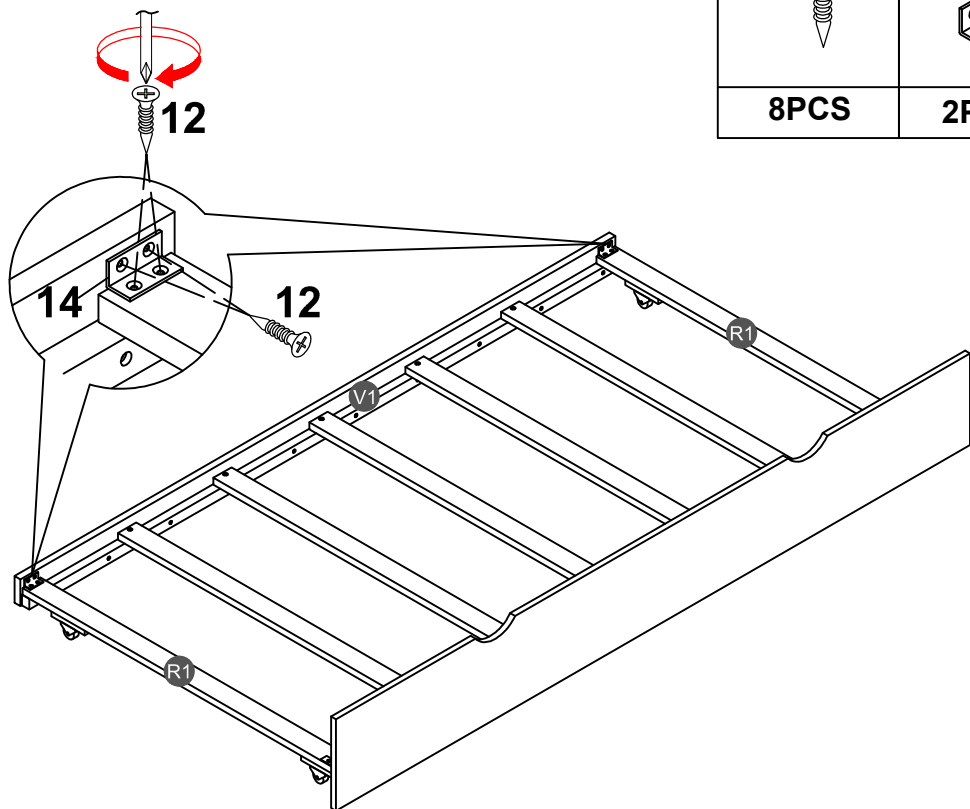

**STEP 21:**

ÉTAPE

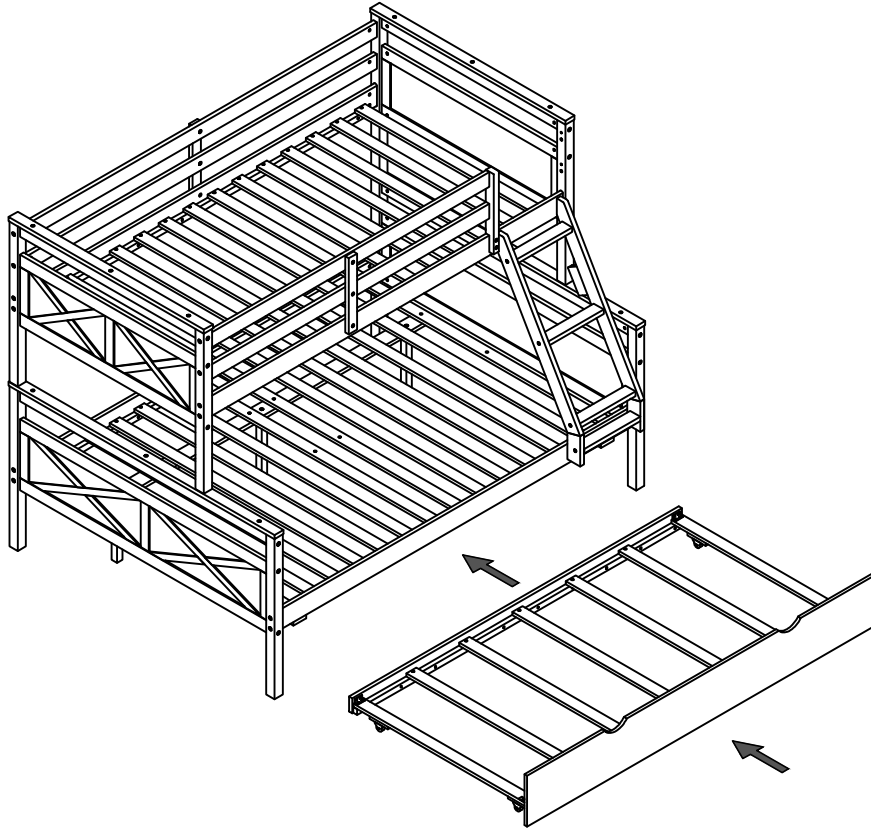

**Push Trundle under the bottom of Bunkbed.**

Poussez le lit gigogne sous le bas du lit superposé.

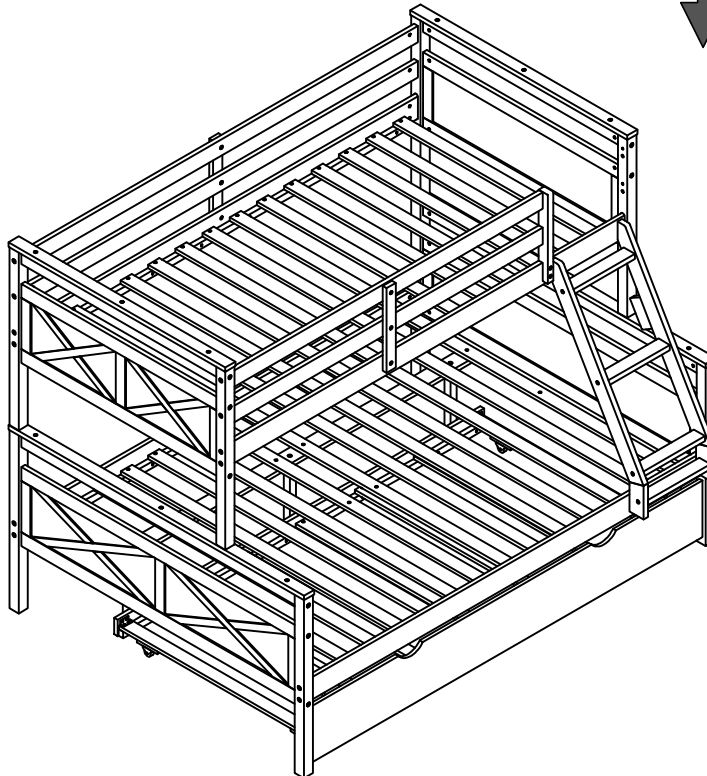

**Make sure to tighten all the screws of the bed.**

Assurez-vous de serrer toutes les vis des de lit.