

ASSEMBLY INSTRUCTIONS

COFFEE TABLE

IMPORTANT NOTE :

- * PLACE ALL WOODEN PARTS ON A CLEAN AND SMOOTH SURFACE SUCH AS A RUG OR CARPET TO AVOID THE PARTS FROM BEING SCRATCHED.
- * BEFORE YOU BEGIN, KINDLY FOLLOW THE ASSEMBLY INSTRUCTIONS STEP BY STEP.

HARDWARE LIST

A	JCBC M6 x 35mm + S/W M6 + F/W M6 x 19mm	12PCS
B	JCBC M6 x 50mm + S/W M6 + F/W M6 x 19mm	4PCS
C	ALLEN KEY M4	1PC

PART LIST

1	TABLE TOP	1PC
2	TABLE LEG	2PCS
3	BOTTOM LEG	2PCS
4	LEG SUPPORT	2PCS

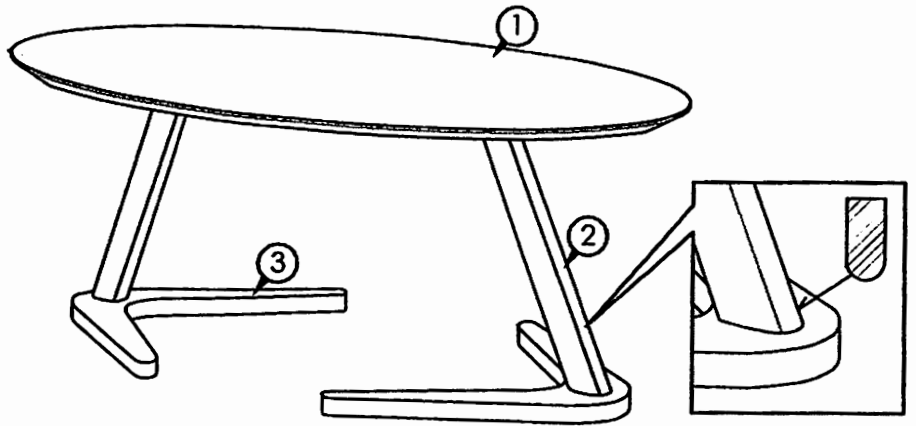

COMPLETED TABLE ASSEMBLY.

STEP 1

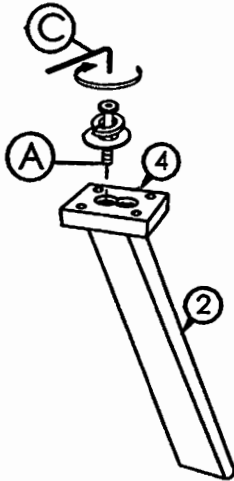

STEP 2

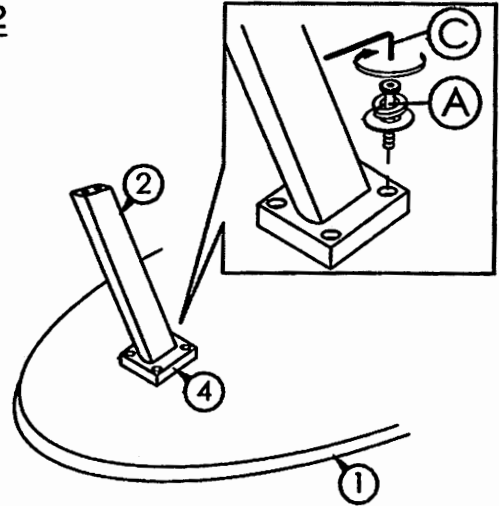

STEP 3

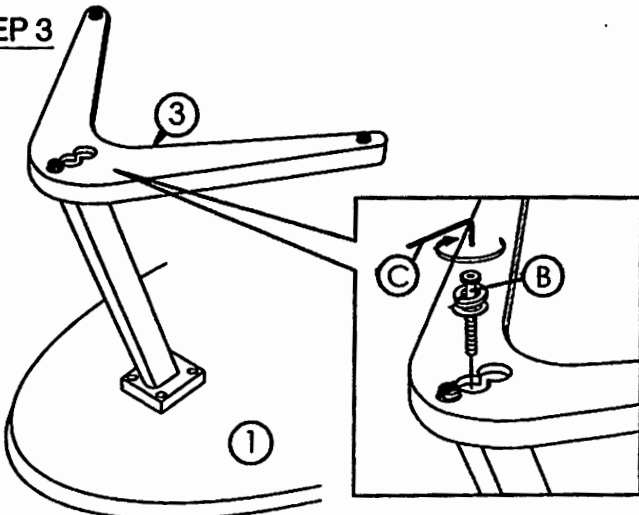

STEP 4

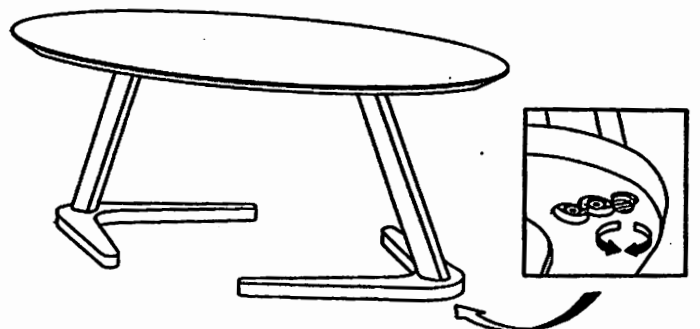

Turn clockwise or anti-clockwise to adjust leg leveller.