

ASSEMBLY INSTRUCTION

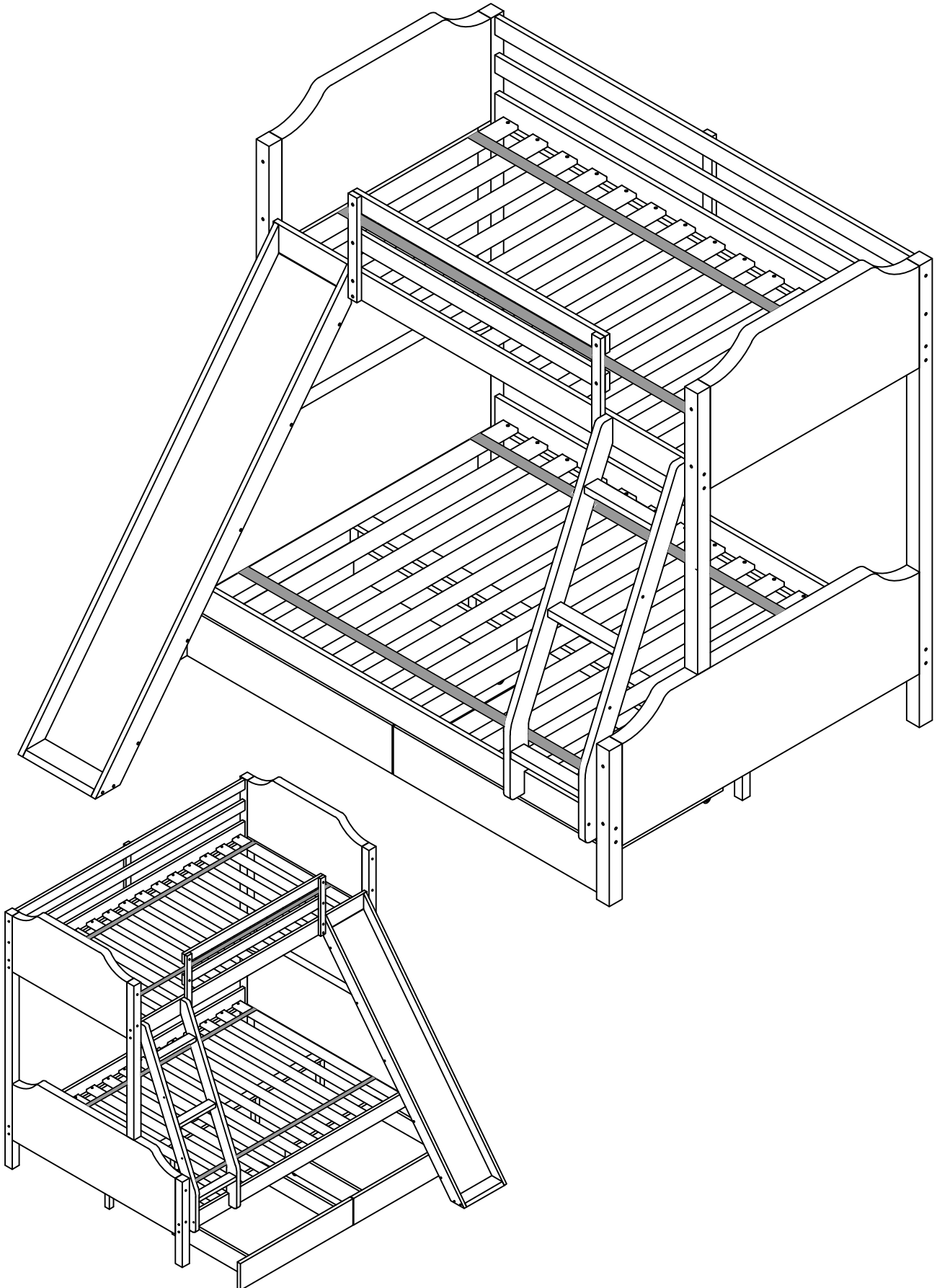

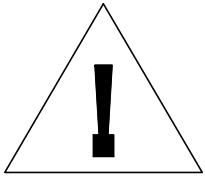

SAFETY WARNINGS

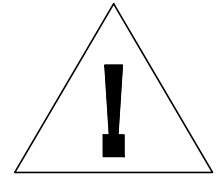

1. This bed is designed for use only mattress(es) meeting the following specifications on the upper bunk:

Upper *bunk*

Bed Type	Length	Width	Thickness
Twin Standard	74"-75"	37 ½"-38 ½"	6"max

Lower bunk

Bed Type	Length	Width	Thickness
Full Standard	74"-75"	54"	6"max





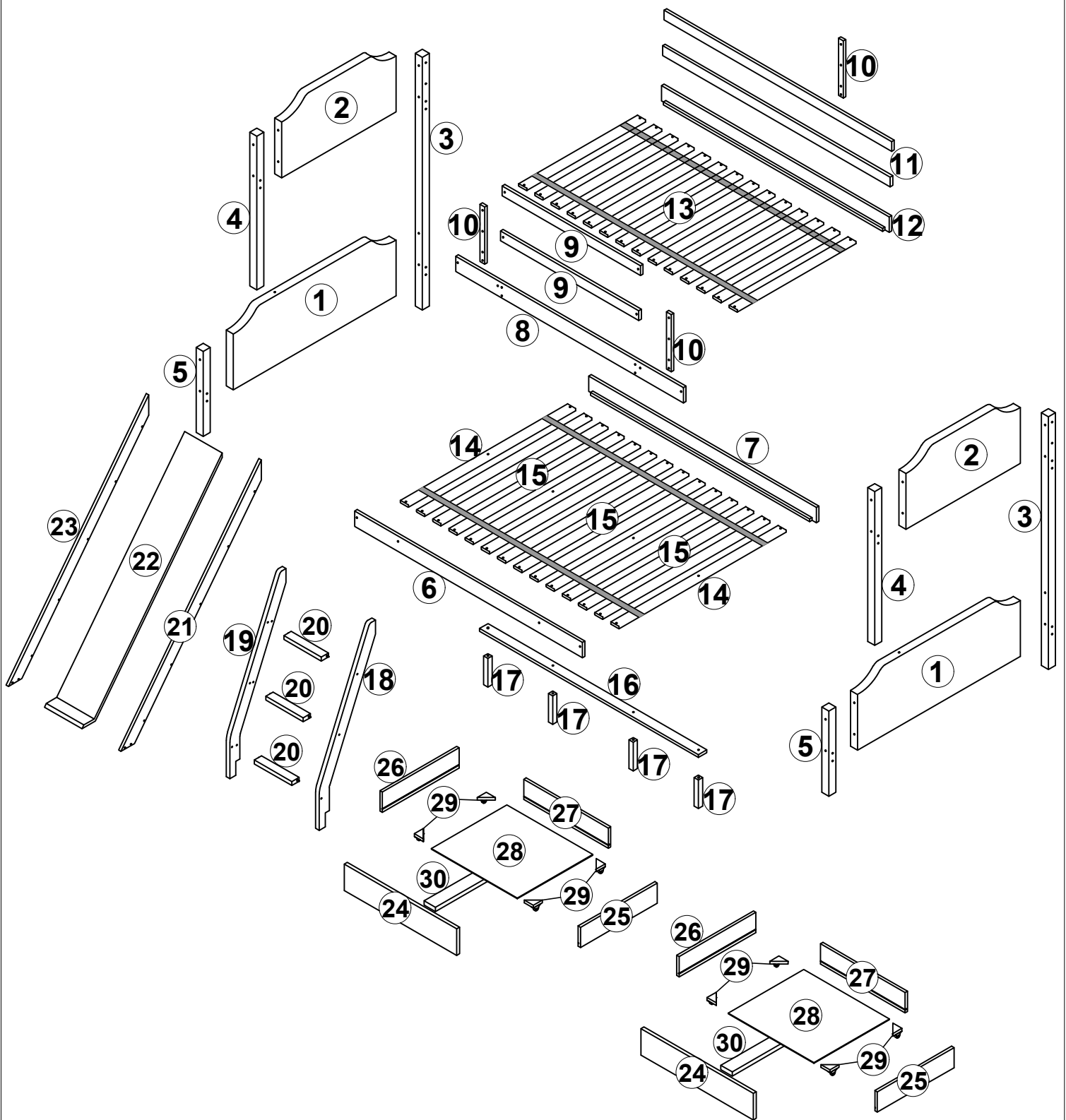

2. Replacement parts, including additional guardrails, maybe obtained
3. Follow the information on the warnings appearing on the upper bunk bed end structure and on the carton. Do not remove warning label from bed.
4. Always use the recommended size mattresses or mattress supports, or both, to help prevent the likelihood of entrapment or falls.
5. Surface of the mattress must be at least 5" . (127 mm) below the upper edge of guardrails.
6. Do not allow children under 6 years of age to use the upper bunk.
7. Periodically check and ensure that the guardrail, ladder, and other components are in their proper position, free from damage, and that all connectors are tight.
8. Do not allow horseplay on or under the bed and prohibit jumping on the bed.
9. Always use the ladder for entering and leaving the upper bunk.
10. Do not use substitute parts. Contact the manufacturer or dealer for replacement parts.
11. Use of a night light may provided added safety precaution for a child using the upper bunk.
12. Always use guardrails on both long sides of the upper bunk. If the bunk bed will be placed next to the wall, the guardrail that runs the full length of the bed should be placed against the wall to prevent entrapment between the bed and wall.
13. The use of water or sleep flotation mattresses is prohibited.
14. STRANGULATION HAZARD - Never attach or hang items to any part of the bunk bed that are not designed for use with the bed; for example, but not limited to, hook, belts and jump ropes.
15. Keep these instructions for future reference.
16. Prohibit more than one person on upper bunk.
17. We recommend assembling your bunk bed on the shipping carton to protect your floor or carpet.
18. Be certain all staples are out of the box before beginning assembly on the shipping carton.

Detail View - BUNK BED

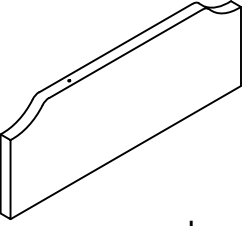
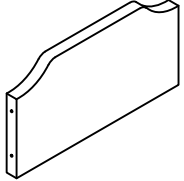
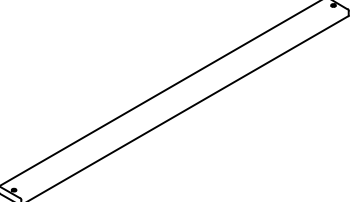
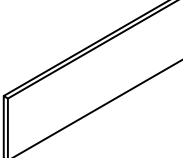

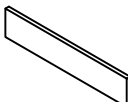

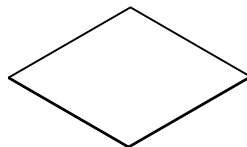

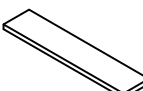



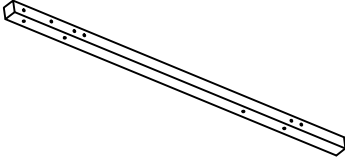
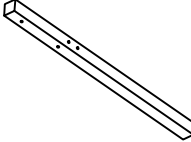

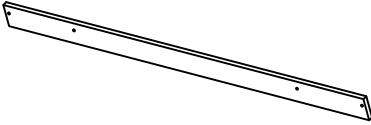
Identifying the Hardware - Identify the hardware using the illustrations below.

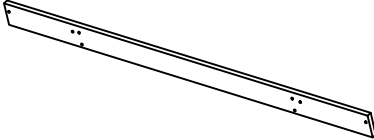
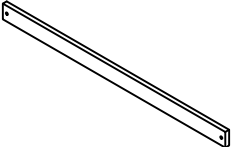

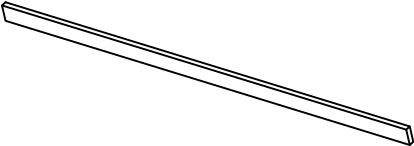
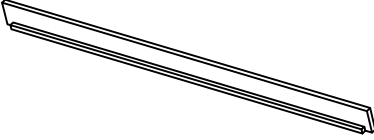
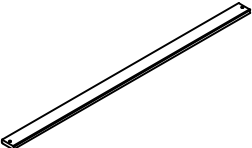
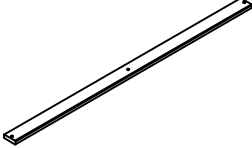
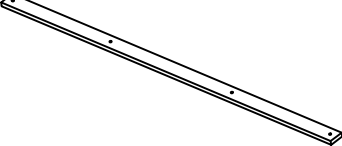

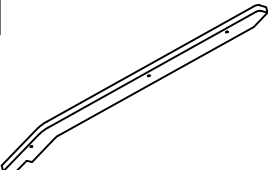
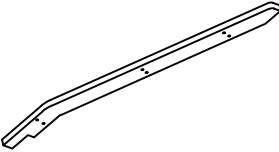

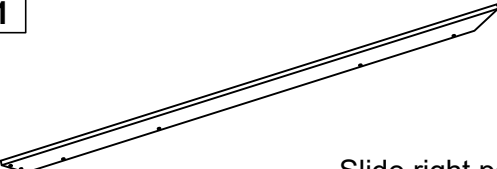
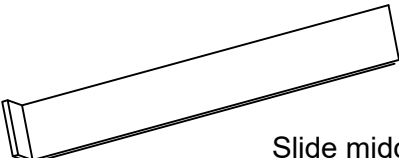
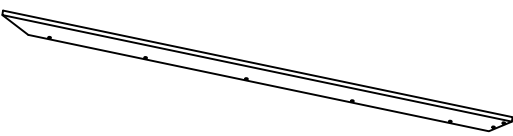
Part Lists: **WF292791**

1		2	
	Lower headboard-2pcs		Upper headboard-2pcs
13		24	
	Upper bed slat-14pcs		Drawer front -2pcs
25		26	
	Drawer side left -2pcs		Drawer side right -2pcs
27		28	
	Drawer back -2pcs		Drawer bottom -2pcs
29		30	
	Corner block -8pcs		Drawer bottom support bar -2pcs

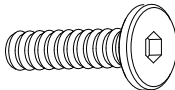
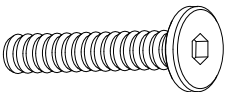
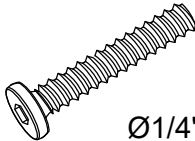
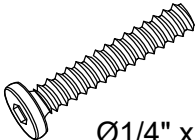
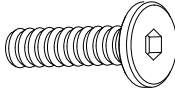
Part Lists: **WF292792**

<p>3</p> 	<p>Back leg-2pcs</p>	<p>4</p> 	<p>Upper front leg -2pcs</p>
<p>5</p> 	<p>Lower front leg-2pcs</p>	<p>6</p> 	<p>Lower front side rail -1pc</p>
<p>7</p> 	<p>Lower back side rail -1pc</p>	<p>8</p> 	<p>Upper front side rail -1pc</p>
<p>9</p> 	<p>Short guardrail -2pcs</p>	<p>10</p> 	<p>Support guardrail -3pcs</p>
<p>11</p> 	<p>Long guardrail -2pcs</p>	<p>12</p> 	<p>Upper back side rail -1pc</p>
<p>14</p> 	<p>Lower slat 1 -10pcs</p>	<p>15</p> 	<p>Lower slat 2 -4pcs</p>
<p>16</p> 	<p>Center support bar -1pc</p>	<p>17</p> 	<p>Center support leg - 4pcs</p>
<p>18</p> 	<p>Ladder right rail -1pc</p>	<p>19</p> 	<p>Ladder left rail -1pc</p>
<p>20</p> 	<p>Ladder step -3pcs</p>	<p>21</p> 	<p>Slide right panel -1pc</p>
<p>22</p> 	<p>Slide middle panel -1pc</p>	<p>23</p> 	<p>Slide left panel -1pc</p>

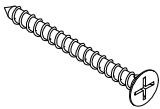
HARDWARE LISTS: WF292791

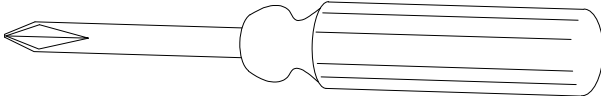
<p>A</p>  <p>4mm Allen key (1pc)</p>	<p>B</p>  <p>Ø1/4" x 80mm Hex-head bolt (20pcs)</p>
<p>C</p>  <p>Ø1/4" x 90mm Hex-head bolt (16pcs)</p>	<p>D</p>  <p>Ø1/4" x 40mm Hex-head bolt (18pcs)</p>
<p>E</p>  <p>Ø1/4" x 60mm Hex-head bolt (6pcs)</p>	<p>F</p>  <p>Ø1/4" x 50mm Hex-head bolt (26pcs)</p>
<p>G</p>  <p>Ø1/4" Spring washer (78pcs)</p>	<p>H</p>  <p>Ø1/4" Flat washer(78pcs)</p>
<p>I</p>  <p>Ø1/4" Barrel nut (24pcs)</p>	<p>J</p>  <p>Ø4 x 30mm Wood screw (80pcs)</p>
<p>K</p>  <p>Ø18 x 100mm Wood dowel (2pcs)</p>	
 <p>ASSEMBLY TOOLS REQUIRED (NOT INCLUDED)</p>	



Read this instruction carefully. See hardware and furniture part list for guidance. Be sure all parts are complete, before you assemble. Place all wooden furniture parts on a clean and flat soft surface to prevent from being scratched. Follow the figure to start assembling.

CAUTIONS :

1. Do not FULLY - TIGHTEN the nut or nut bolt until all nut or bolt is ready assembled.
2. Do not OVER - TIGHTEN the nut or bolt to avoid causing damages to the thread.
3. Keep all hardware parts out of reach of children.



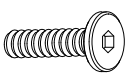

NOTE : THE LIST AND QUANTITY SHOWN ARE FOR 1 UNIT ASSEMBLY.

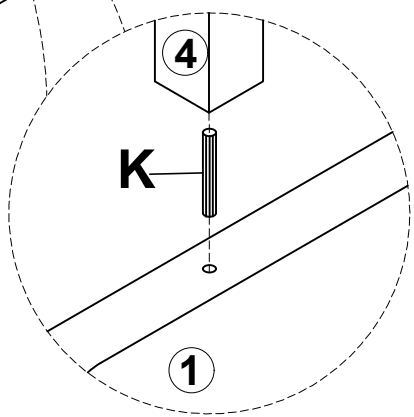
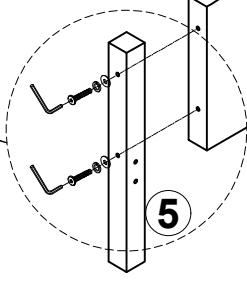
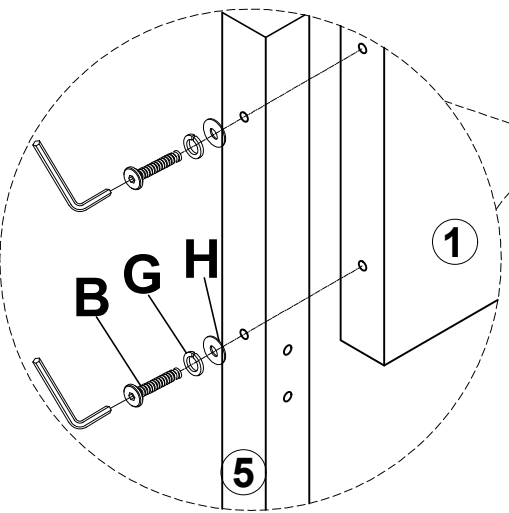
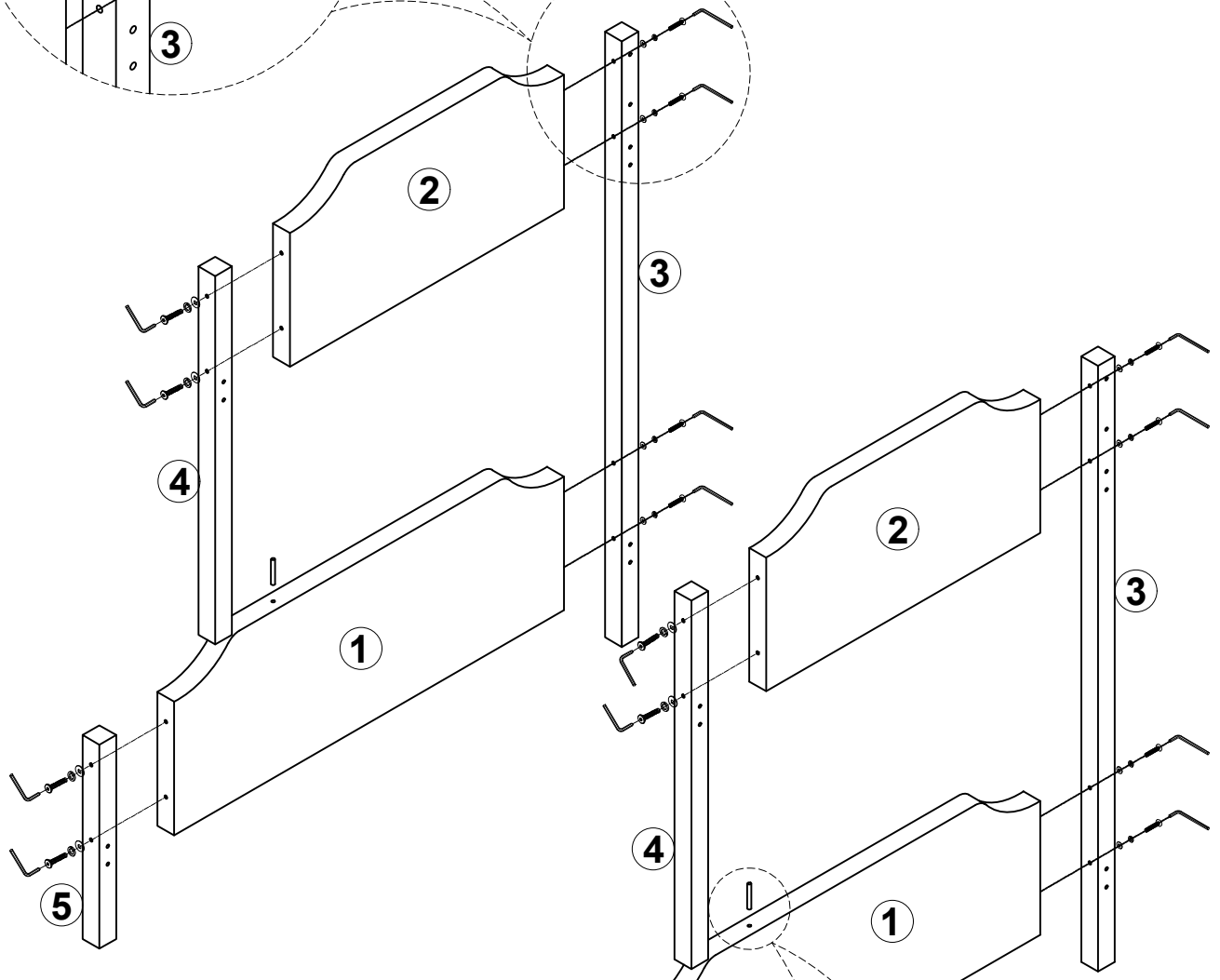
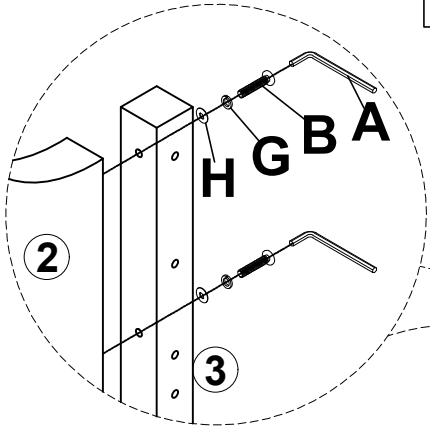
STEP 1

K		H		G		B	
	2PCS		16PCS		16PCS		16PCS

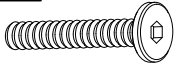

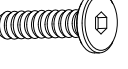

STEP 2

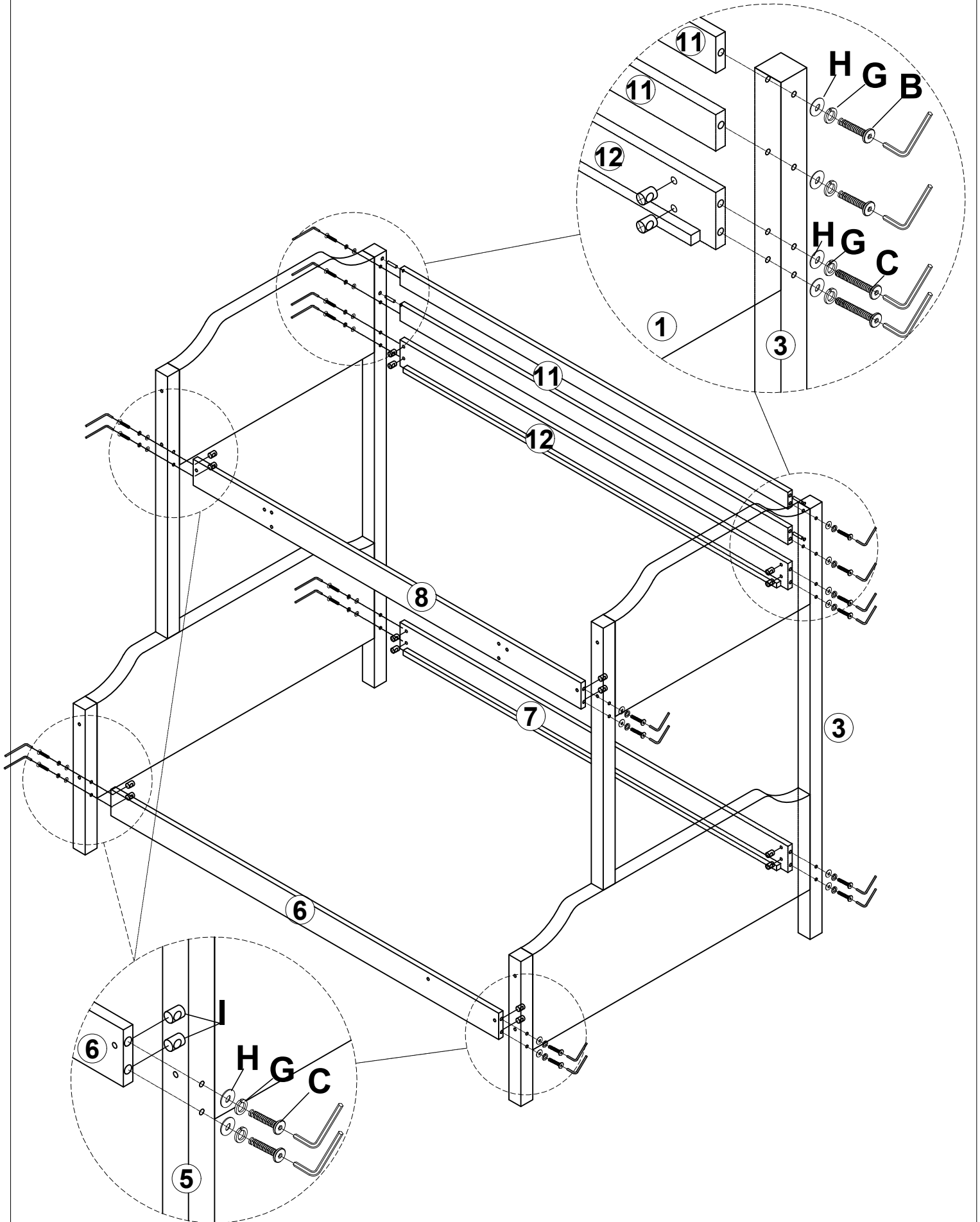
C 	I 	G 	H 	B 
16PCS	16PCS	20PCS	20PCS	4PCS



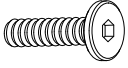

STEP 3

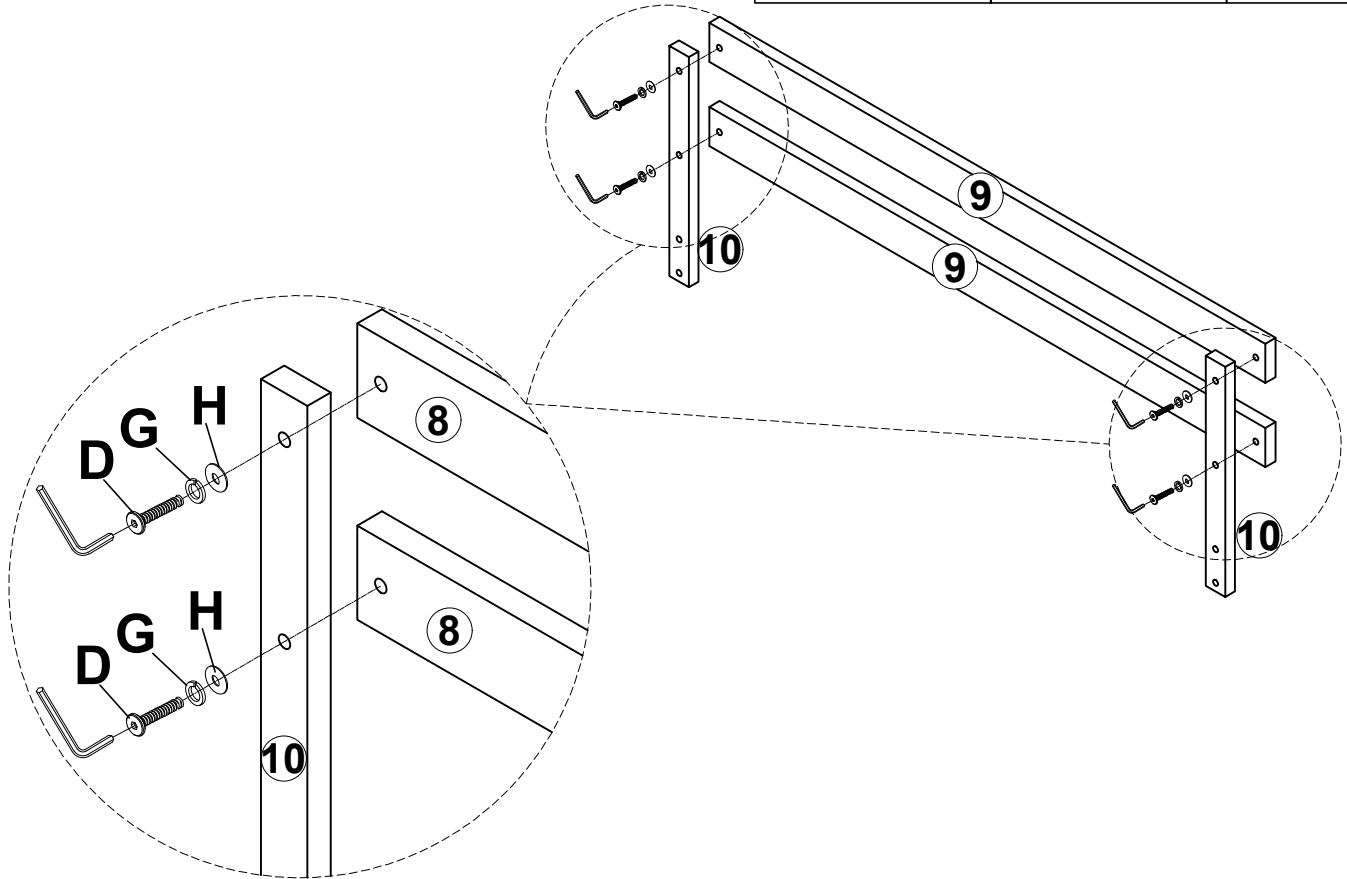
H		G		D	
4PCS		4PCS		4PCS	



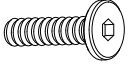

STEP 4

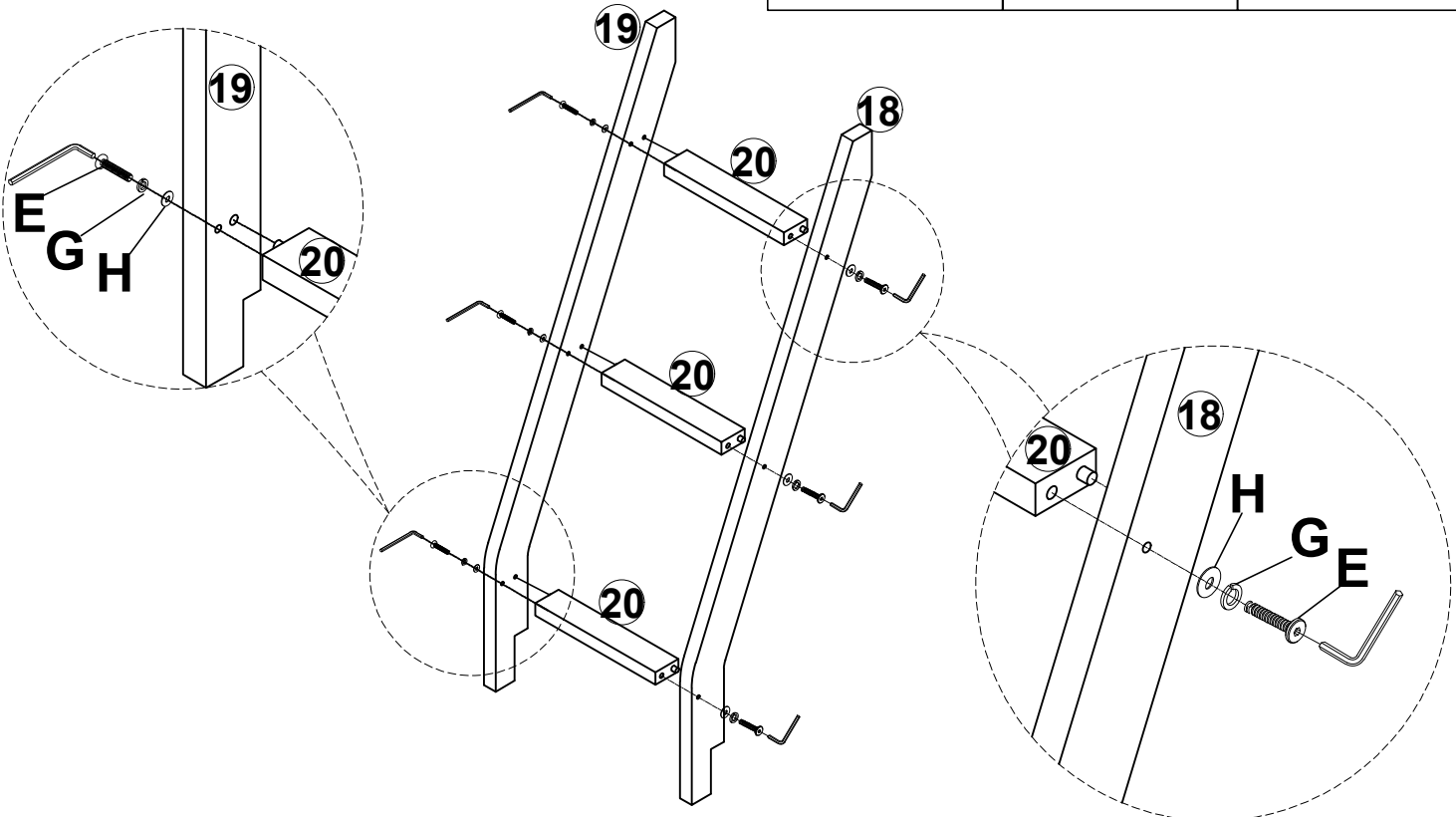
G		H		E	
6PCS		6PCS		6PCS	



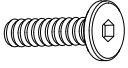

STEP 5

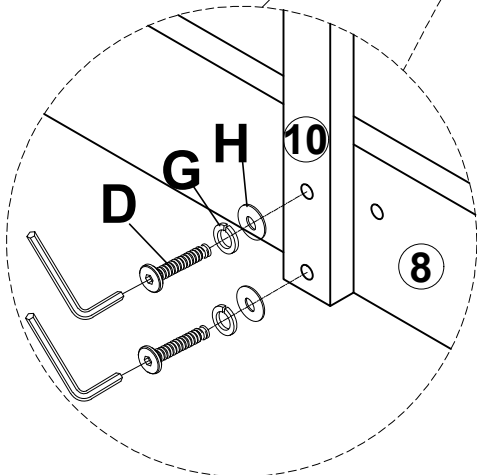
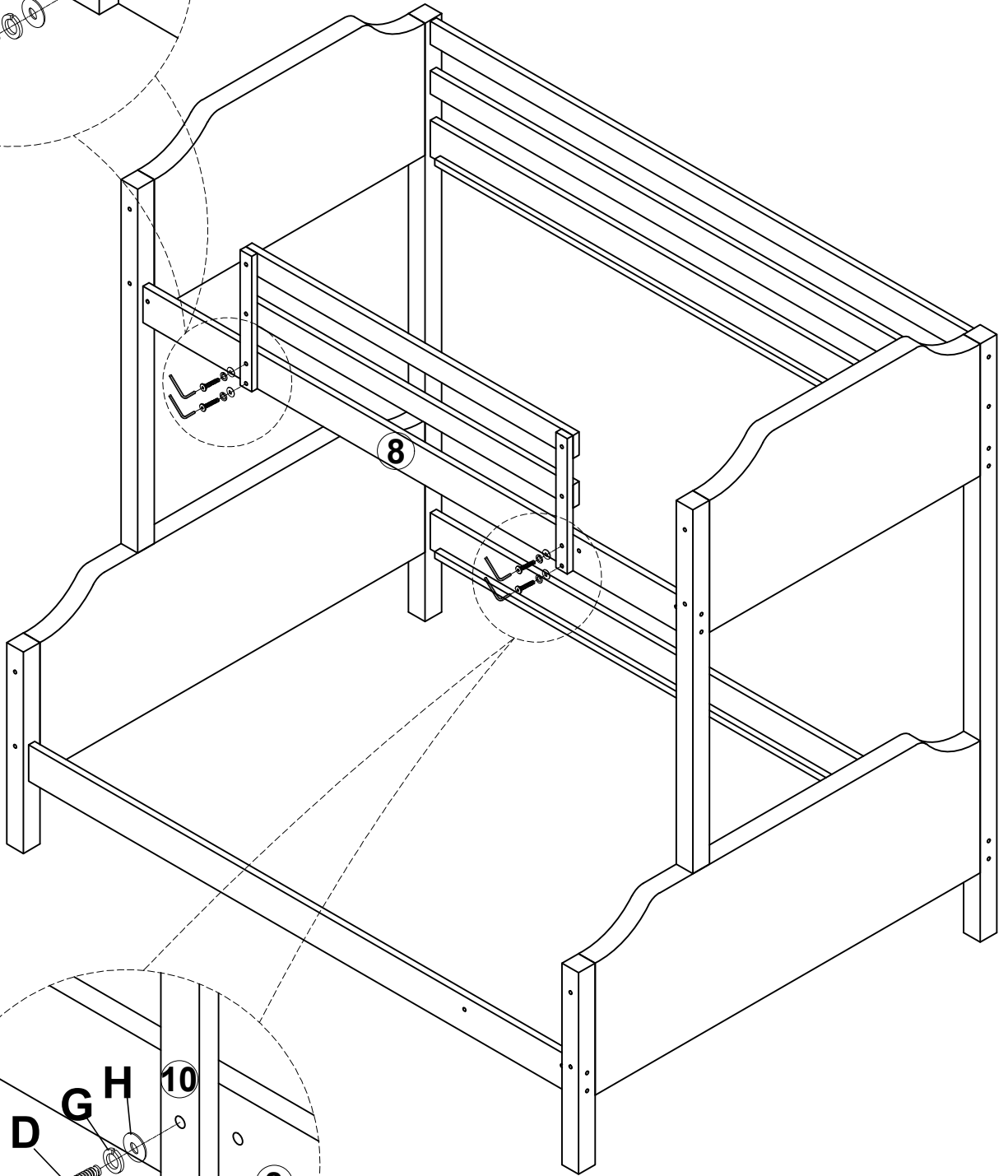
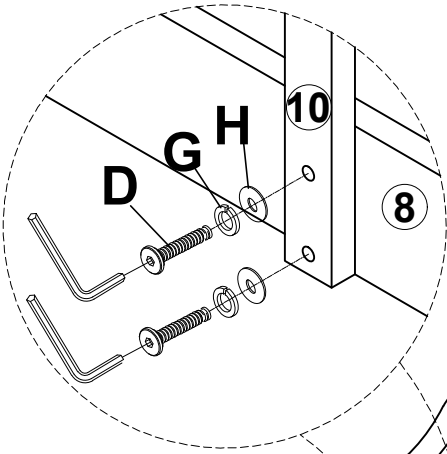
G 	H 	D 
4PCS	4PCS	4PCS



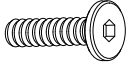

STEP 6

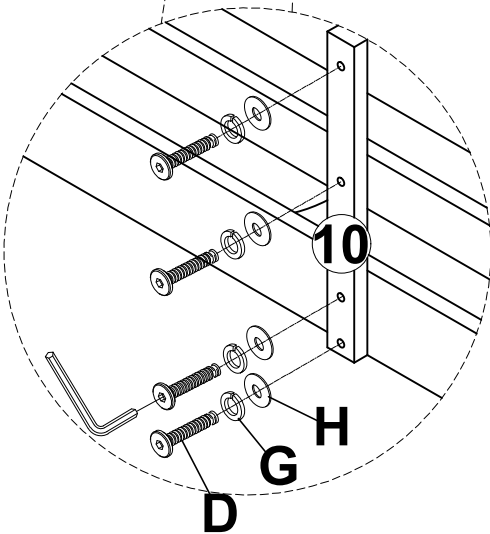
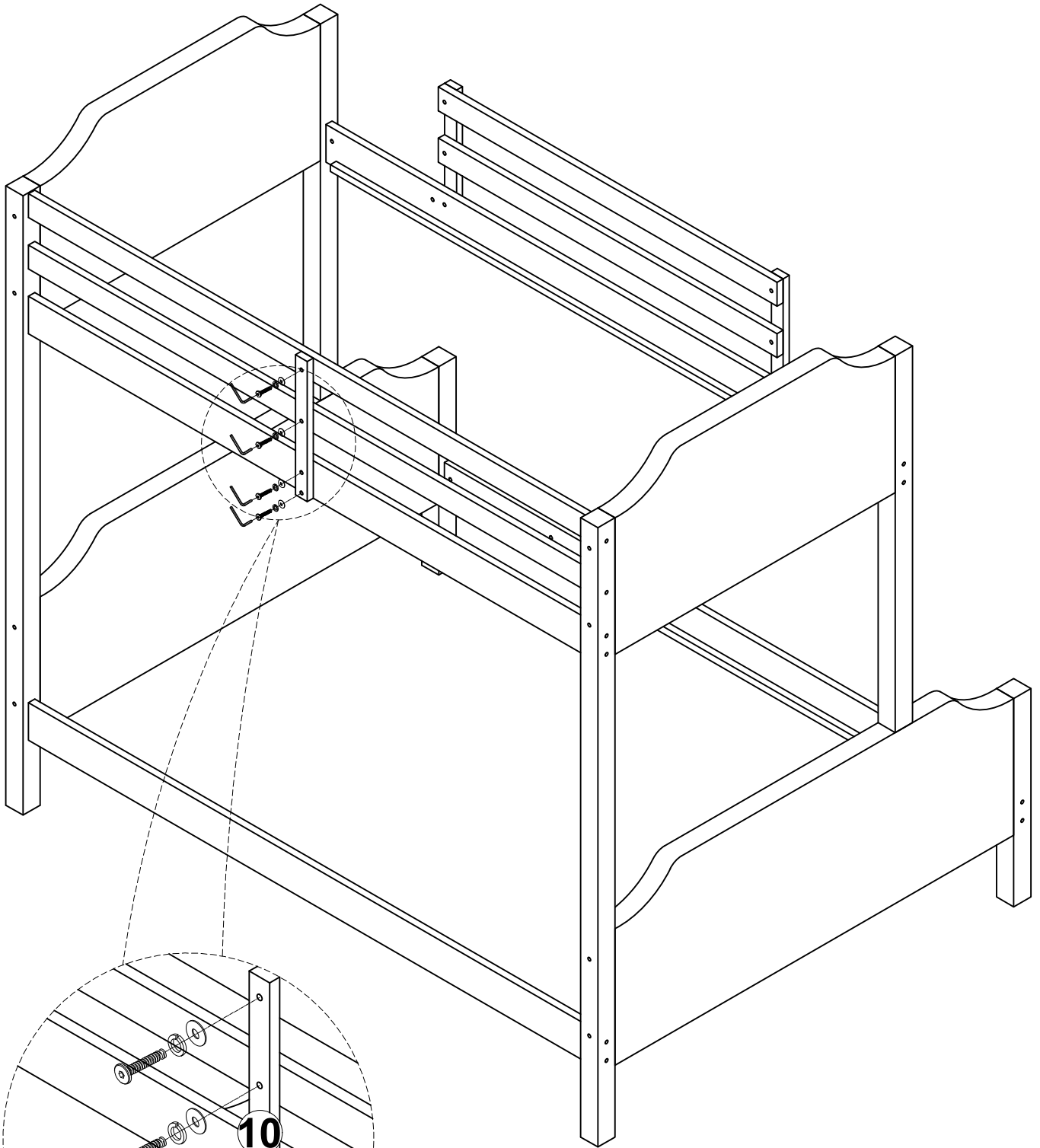
G 	H 	D 
4PCS	4PCS	4PCS



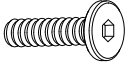

STEP 7

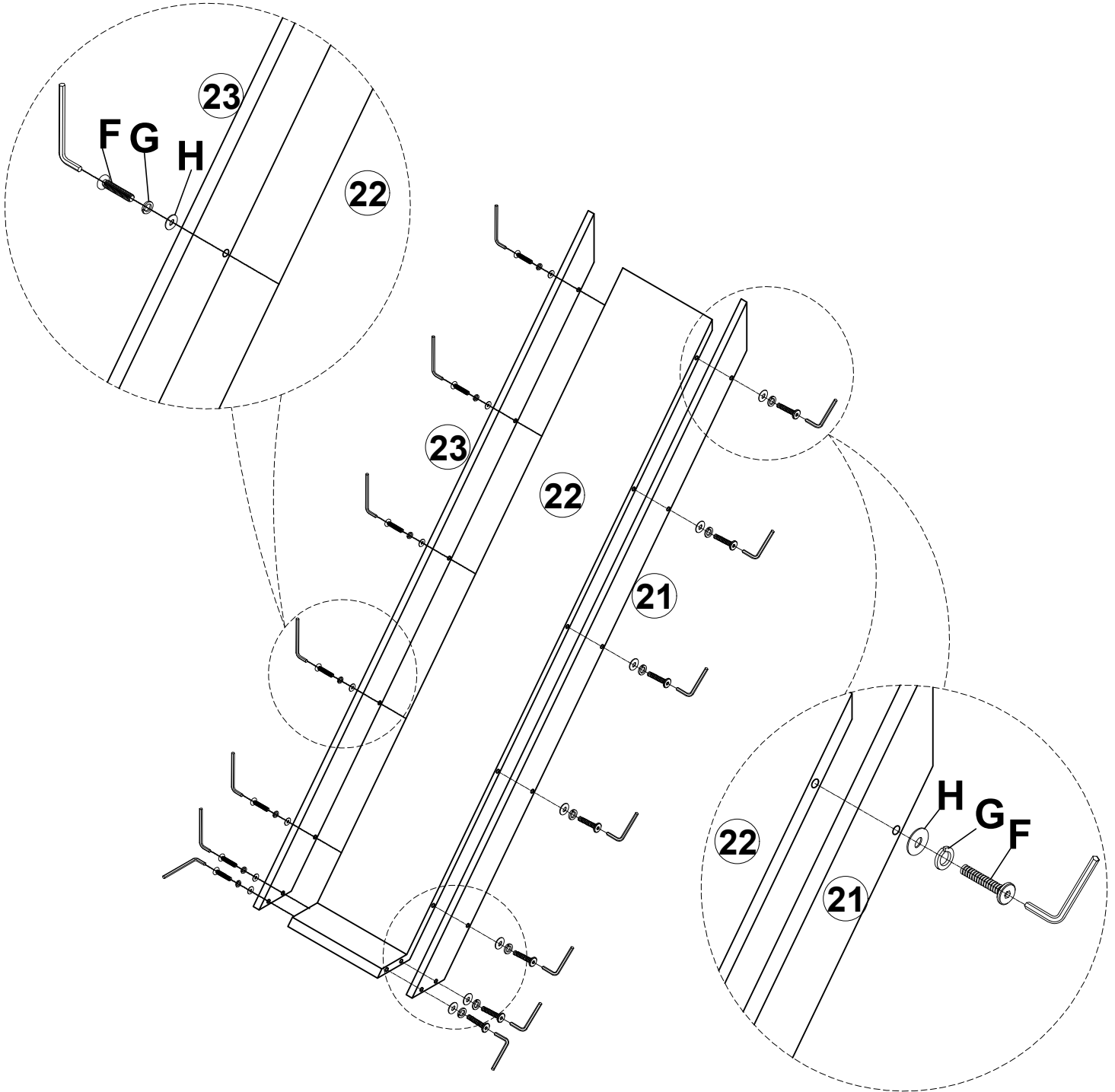
G		H		F	
14PCS		14PCS		14PCS	



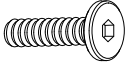

STEP 8

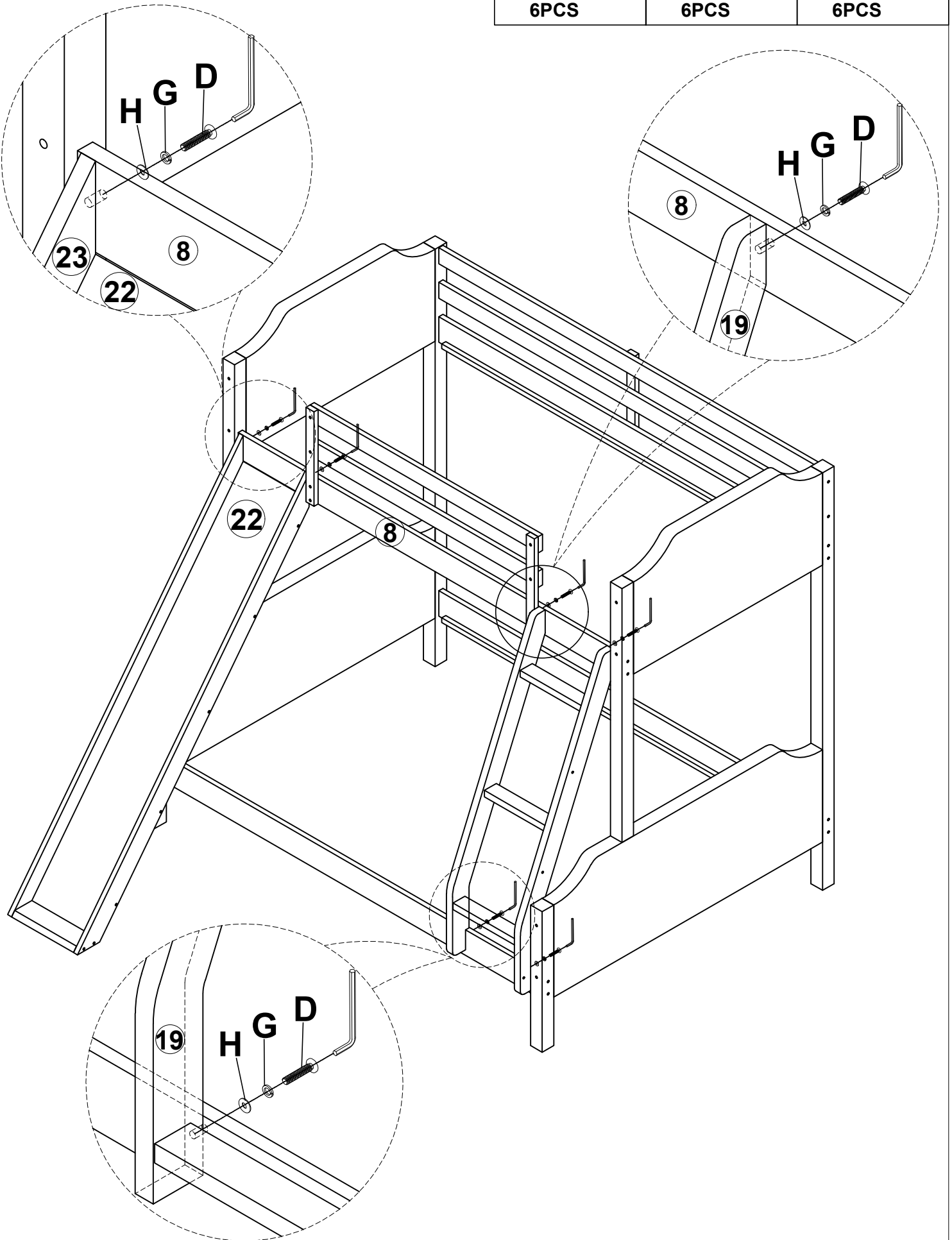
G 	H 	D 
6PCS	6PCS	6PCS

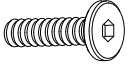

STEP 9

G 	H 	F 
4PCS	4PCS	4PCS

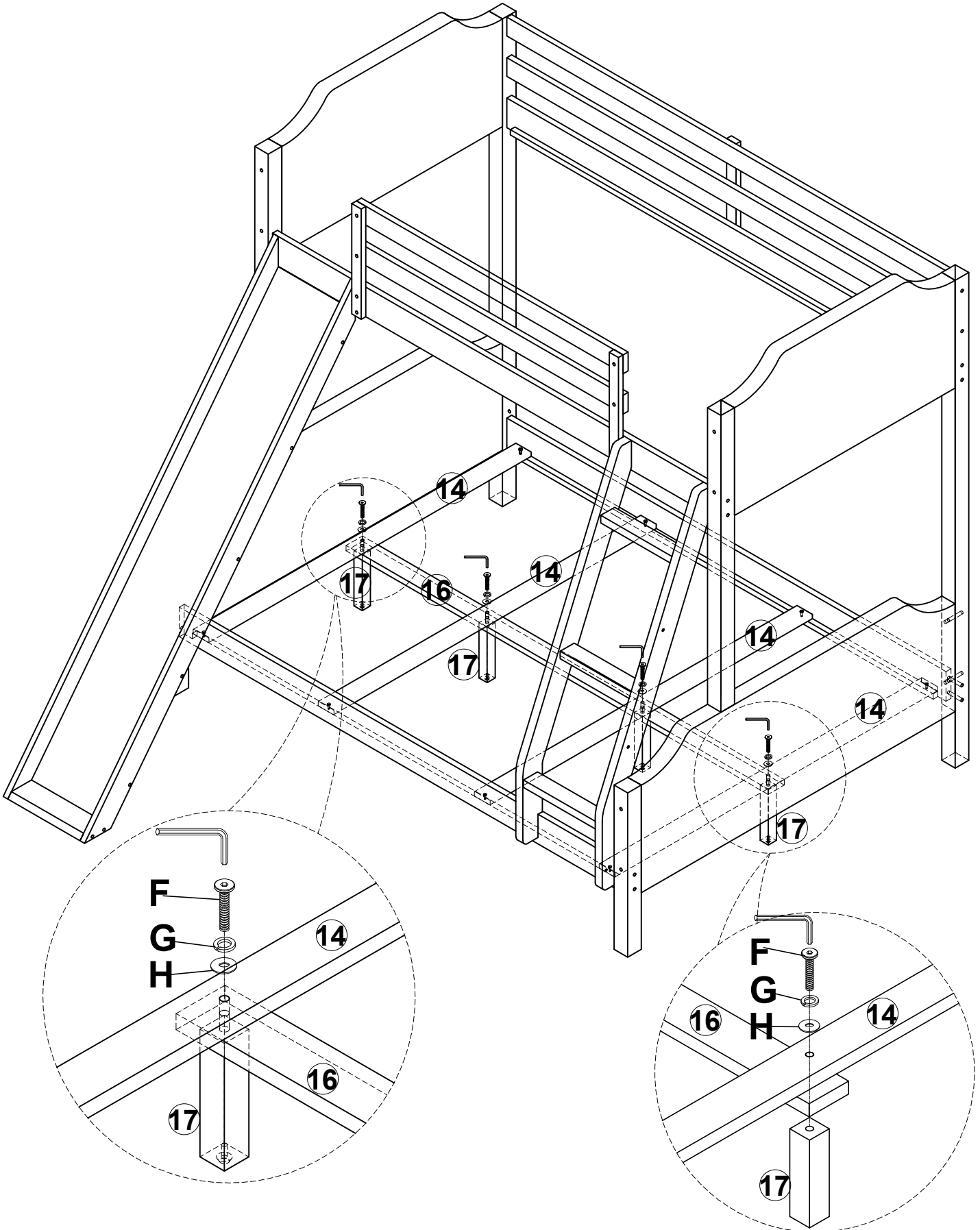

STEP 10

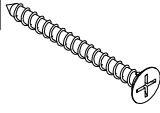
J	
56PCS	

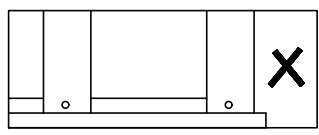
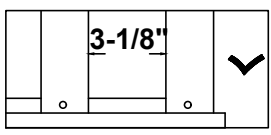
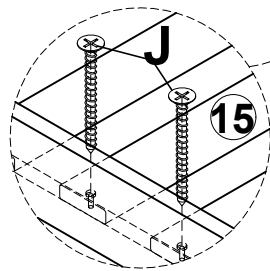
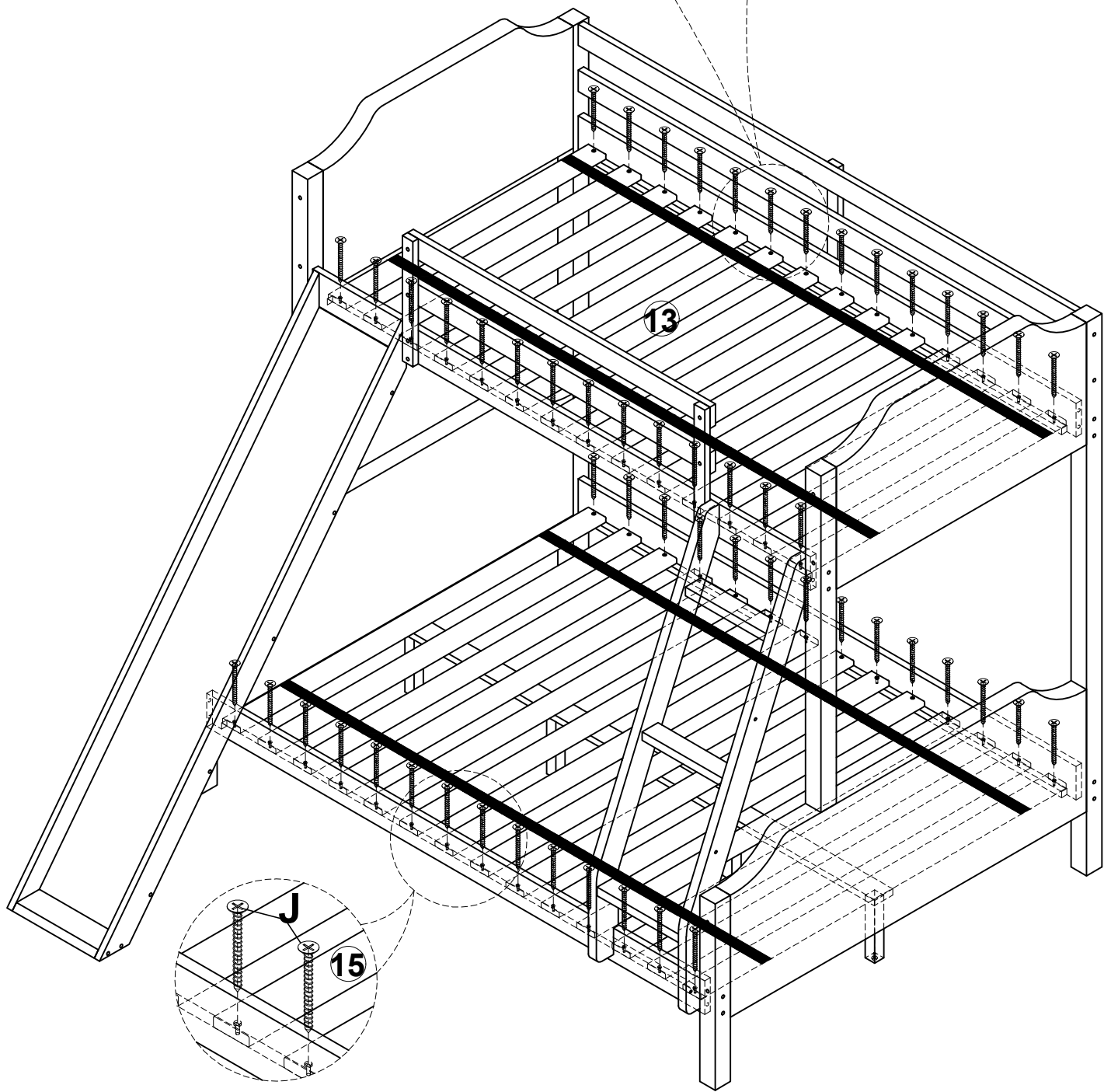
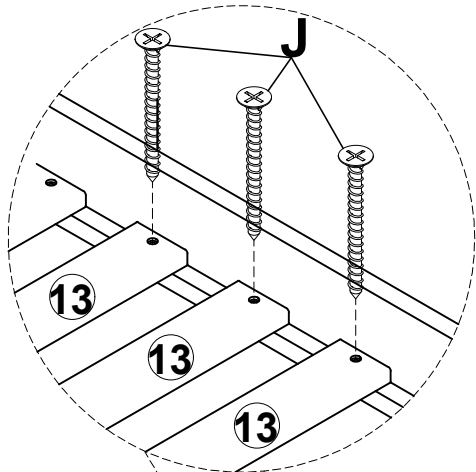

STEP 11

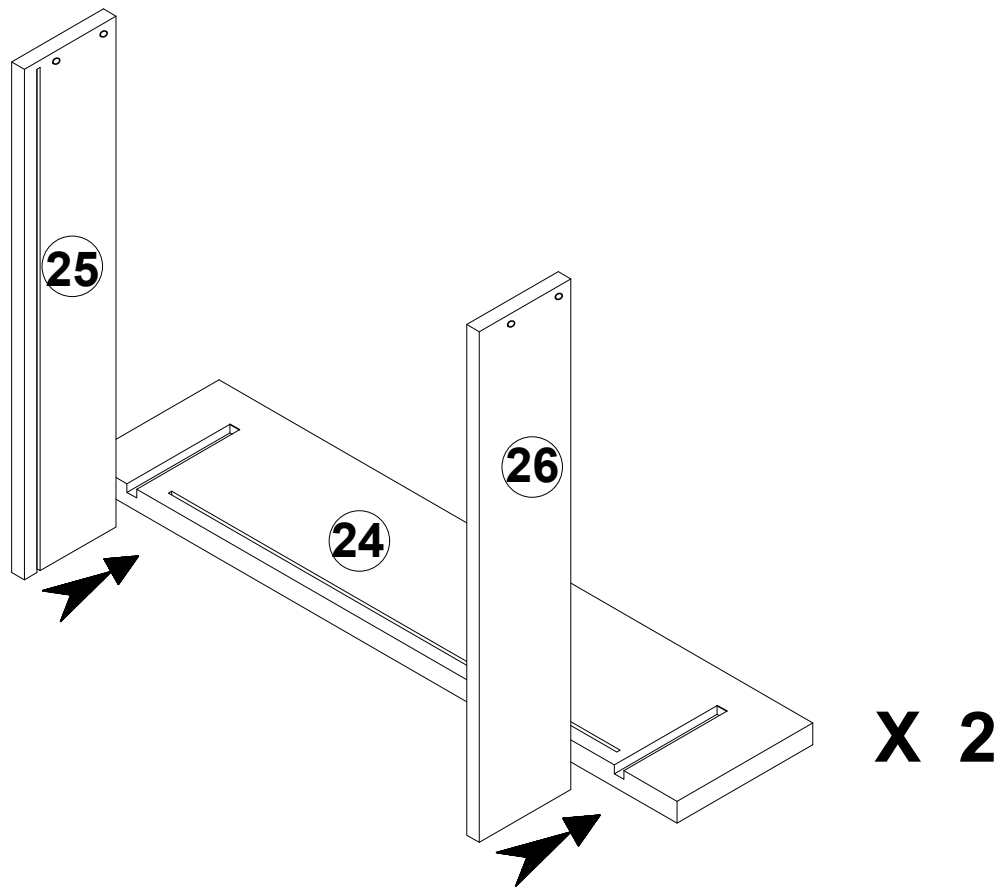

STEP 12

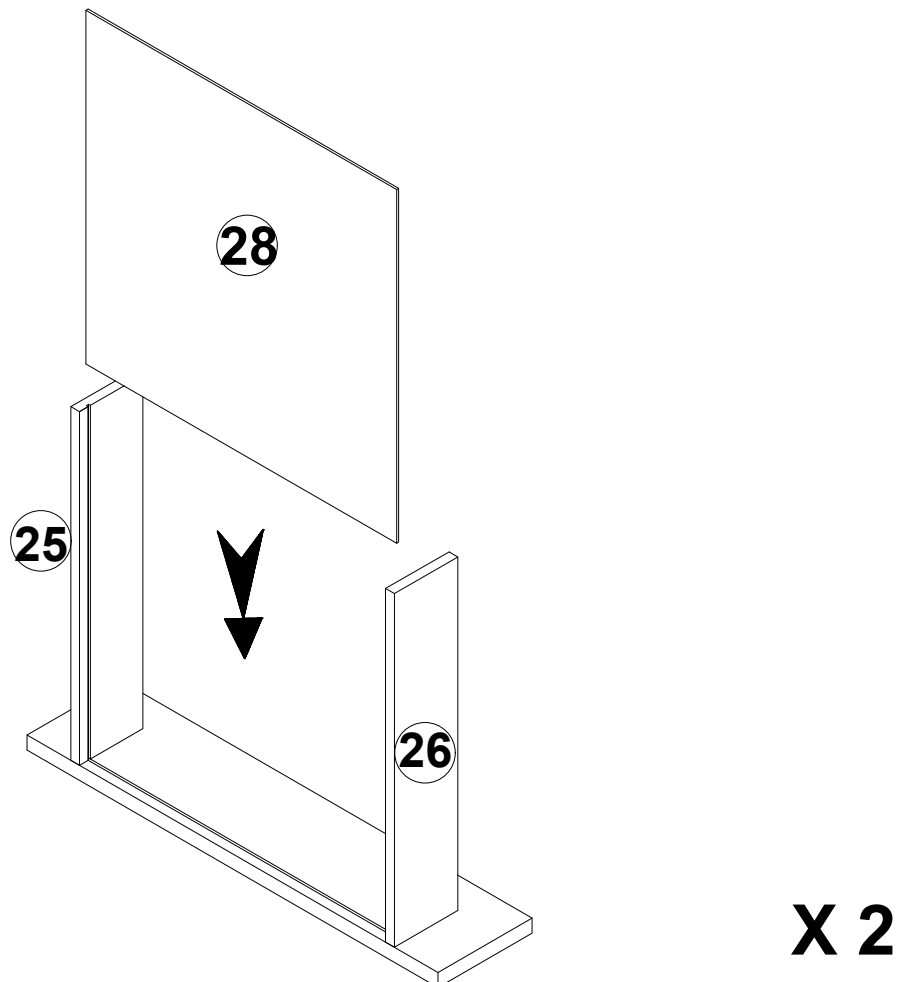

STEP 13

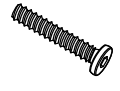
I		F	
8PCS		8PCS	

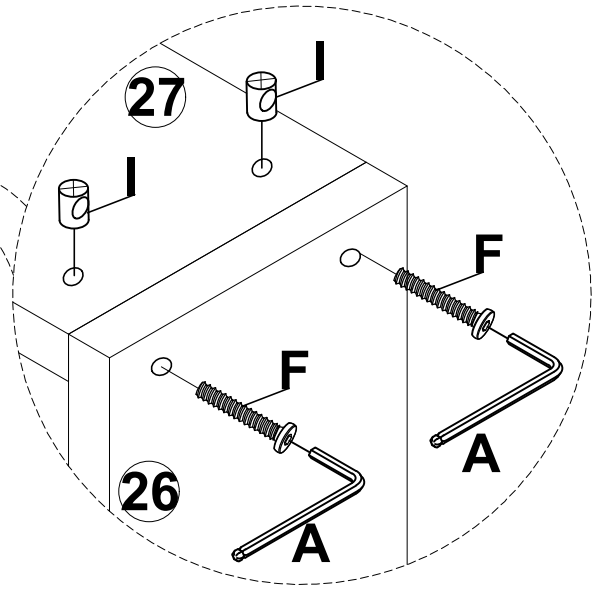
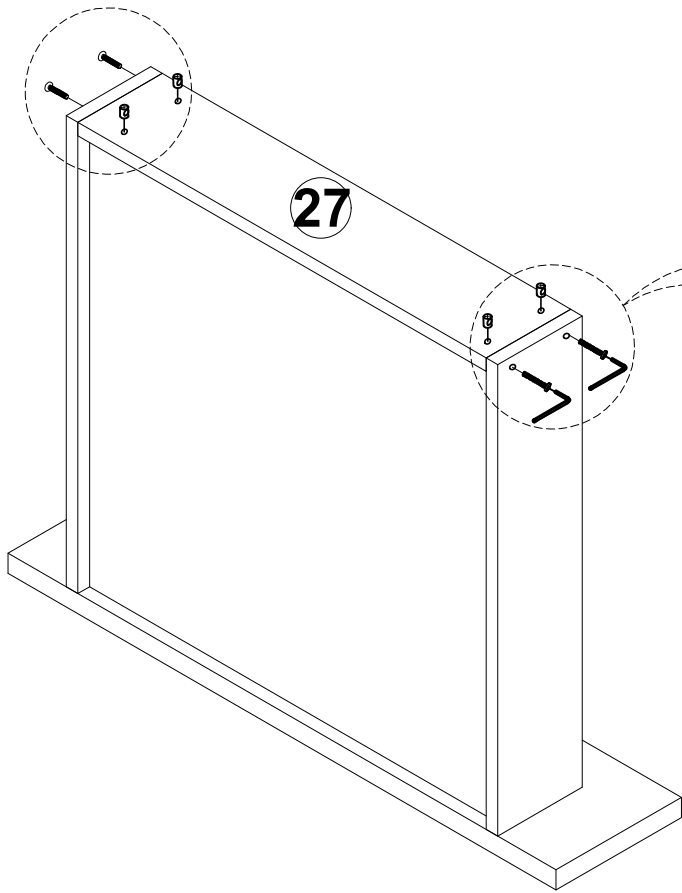

X 2

STEP 14

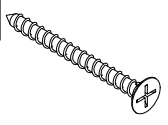
J	
16PCS	

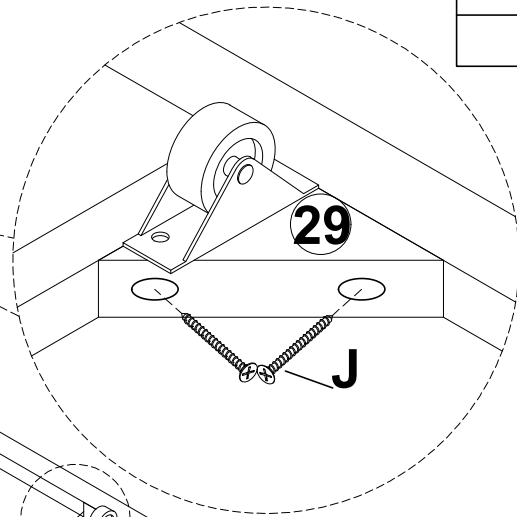
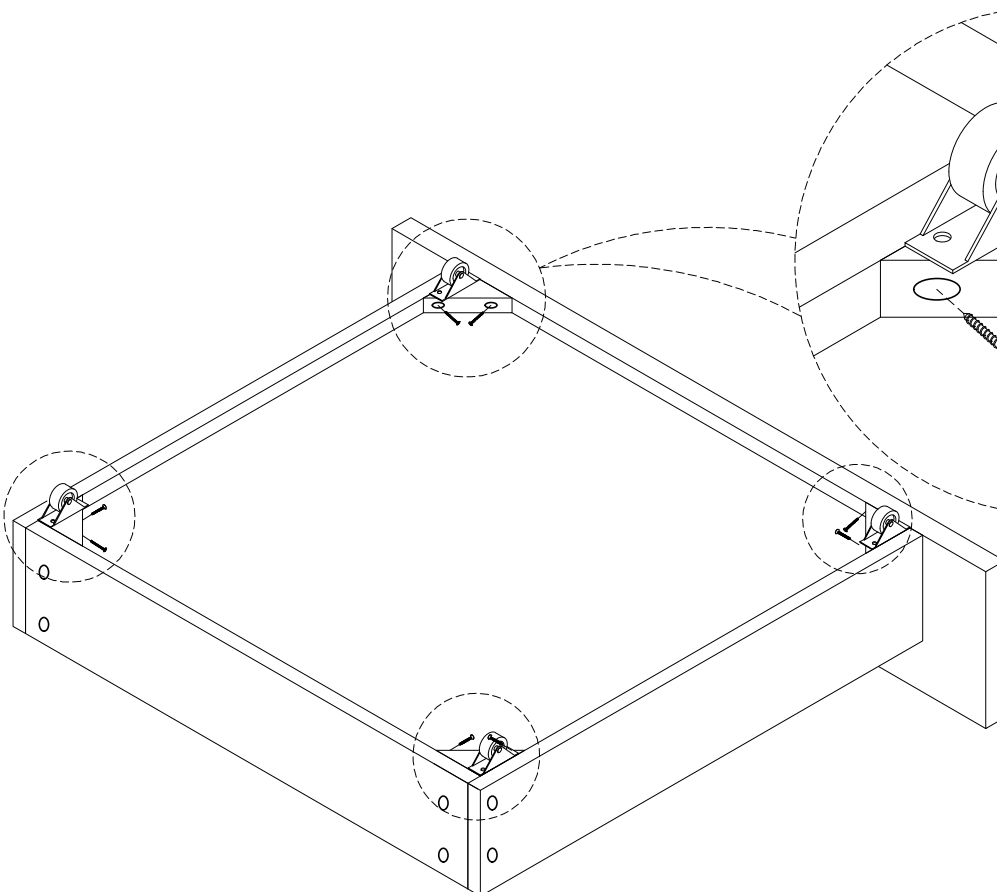

X 2

STEP 15

J

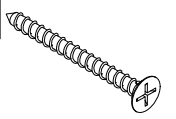

8PCS

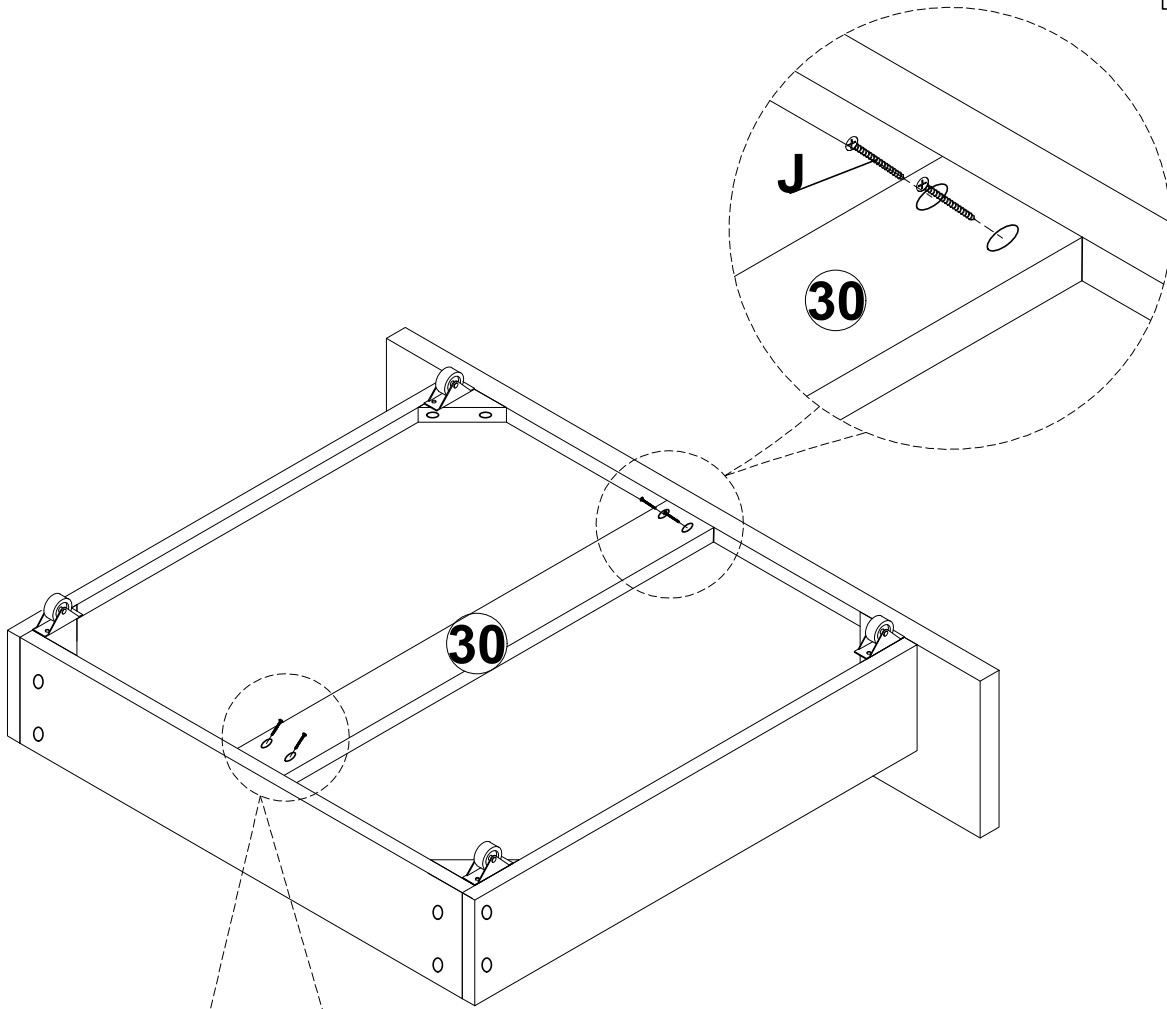

J

30

30

J

30

X 2

STEP 16

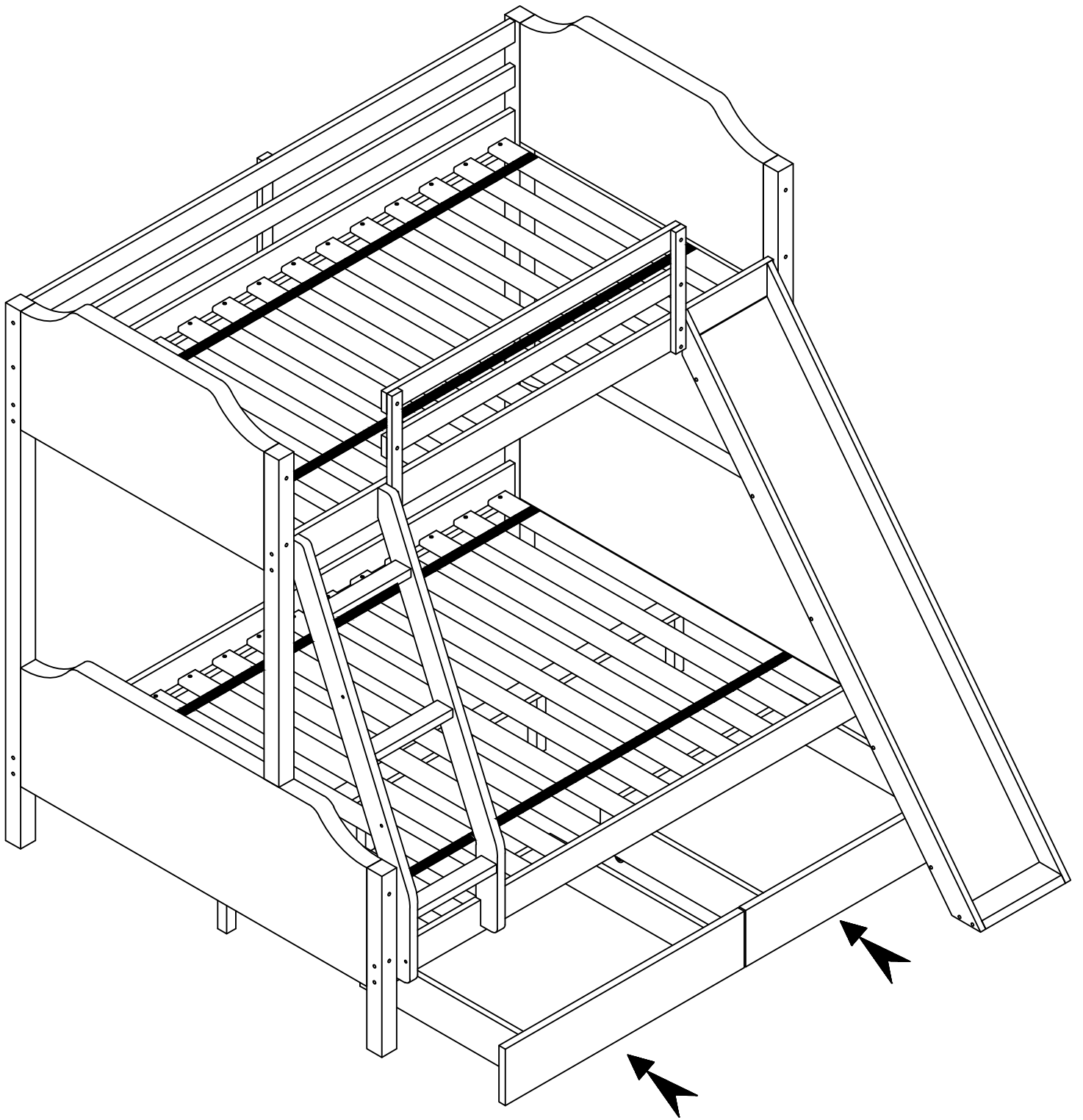

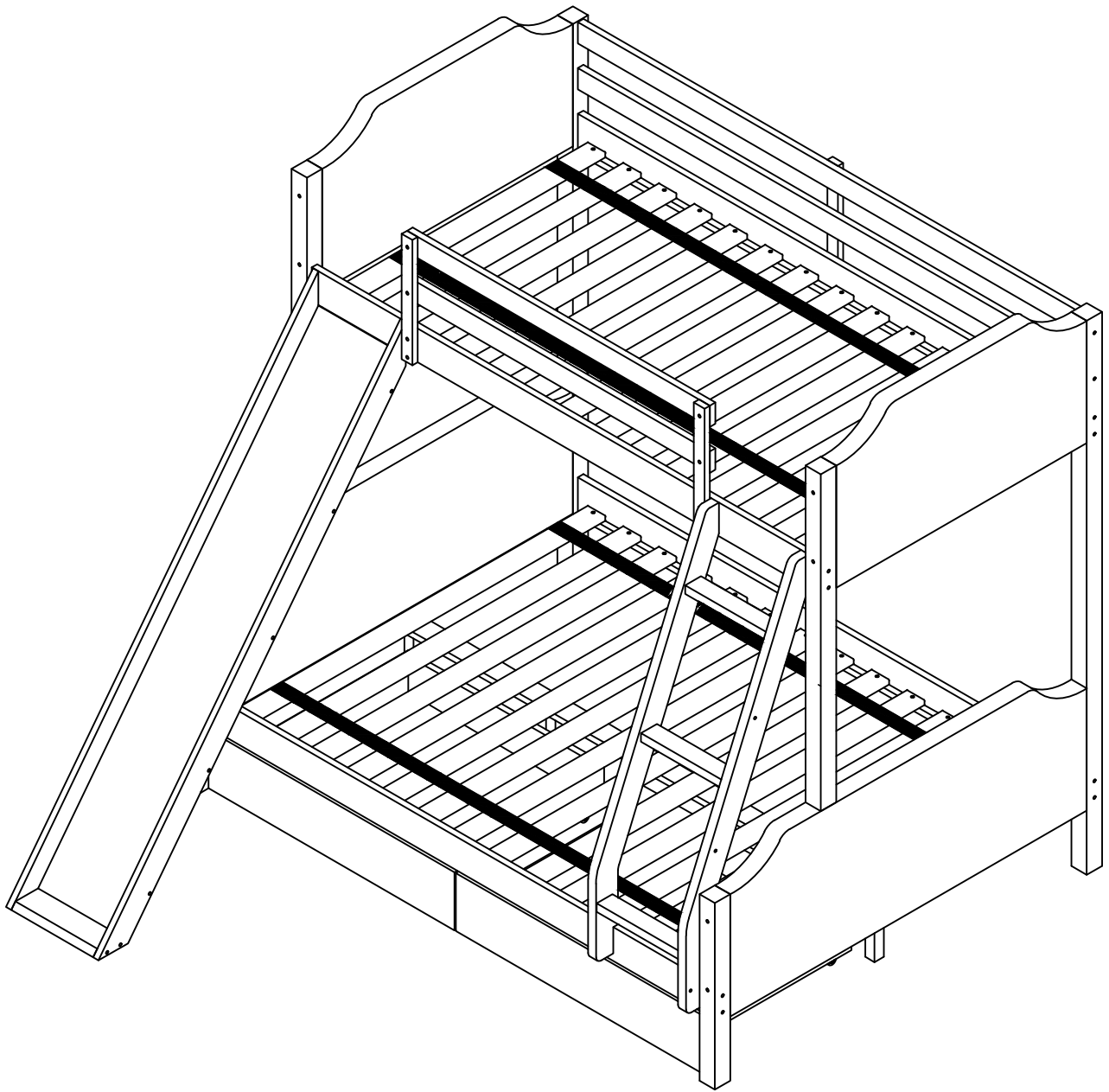

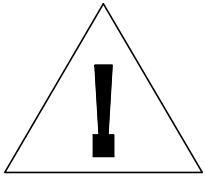

SAFETY WARNINGS

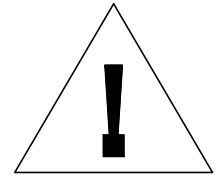

KEEP AI for future use

1. At the beginning :
Tighten all hardware.
Check metal parts for rust. If found, sand and repaint using a non-lead-based paint meeting the requirements of 16 CFR 1303.
Check all wood members for deterioration and splinters. Sand down splinters and replace deteriorating wood members.
Rake and check depth of loose fill protective surfacing materials to prevent compaction and to maintain appropriate depth. Replace as necessary.
2. Twice a month
Tighten all hardware.
Rake and check depth of loose fill protective surfacing materials to prevent compaction and to maintain appropriate depth. Replace as necessary.
3. Owners shall be responsible for maintaining the legibility of the warning labels.
4. Disposal Instructions-
There shall be instructions advising the owner to disassemble and dispose of the playground equipment in such a way that no unreasonable hazards will exist at the time the playground equipment is discarded.
5. The instructions shall also include the information found in Section 4 of the United States Consumer Product Safety Commission's (USCPSC) Outdoor Home Playground Safety Handbook or specific surfacing guidelines for the product consistent with the USCPSC Handbook. A copy of this section may be found in Appendix X2.
6. Observing the following statements and warnings reduces the likelihood of serious or fatal injury.
7. Specifying the number and weight of occupants that may safely use the equipment singly or simultaneously,
8. Recommending on-site adult supervision for children of all ages,
9. Warning the owner to instruct children not to use the equipment in a manner other than intended,
10. Warning the owner to instruct children not to get off equipment while it is in motion,
11. Warning the owner not to allow children to wear inappropriate items, such as but not limited to, loose fitting clothing, hood and neck drawstrings, scarves, cord-connected items, capes and ponchos. These items can cause death by strangulation.
12. Warning the owner to instruct children not to climb when the equipment is wet.
13. Warning the owner to instruct children not to attach items to the playground equipment that are not specifically designed for use with the equipment, such as, but not limited to, jump ropes, clothesline, pet leashes, cables and chain as they may cause a strangulation hazard
14. Warning the owner to instruct children to remove their bike or other sports helmet before playing on the playground equipment.
15. Warning the owner to dress children with well-fitting and full foot enclosing footwear. Examples of inappropriate footwear are clogs, flip flops, and sandals.
16. Place the equipment on level ground, not less than 6 ft (1.8 m) from any structure or obstruction such as a fence, garage, house, overhanging branches, laundry lines, or electrical wires
17. Do not install home playground equipment over concrete, asphalt, packed earth, grass, carpet, or any other hard surface. A fall onto a hard surface can result in serious injury or death to the equipment user
18. To prevent serious injury, cautionary statements shall be included which warn that children must not use the equipment until properly installed.