

PLEASE FOLLOW BELOW INSTRUCTION TO PREVENT PRODUCT TIP OVER.

HARDWARE LIST			QTY
			2 SETS

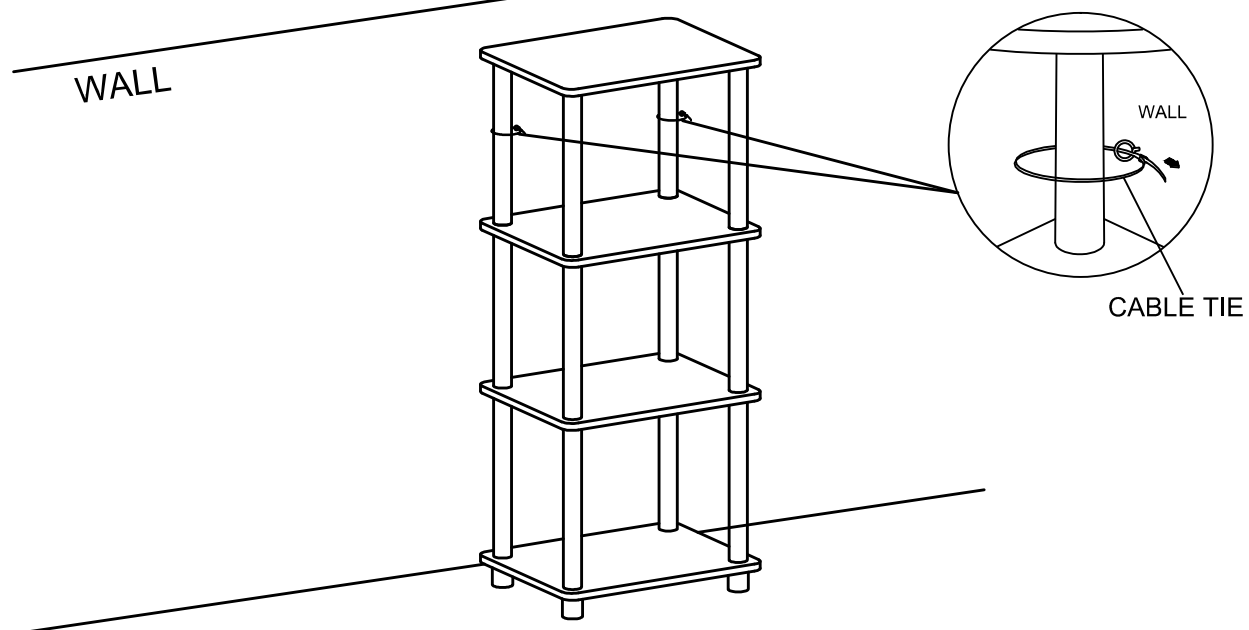

Recommended Maximum Weight

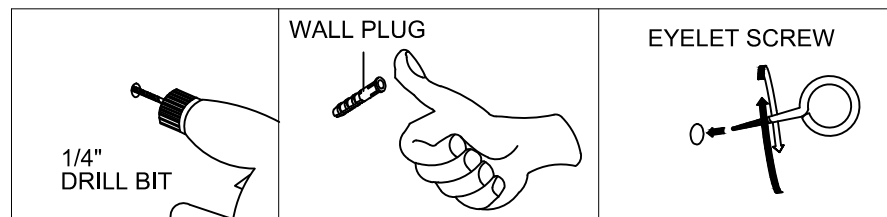
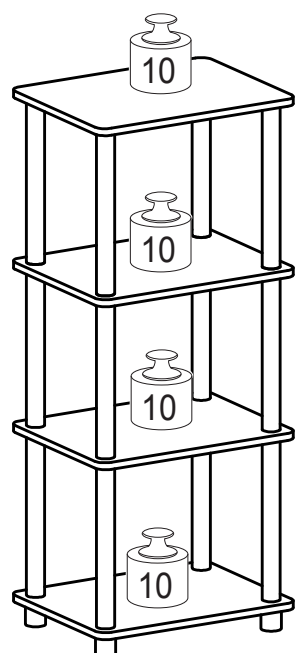

*Unit in Pound(lbs)

WARNING:

>This unit has been designed to support the maximum loads shown. Exceeding these load limits could cause sagging, instability, product collapse, and/or serious injury.

>DO NOT allow children to climb on unit.

>Put heavier items on lower shelves.

00:15

Approx. 15 minutes

Recomm. 1 Person



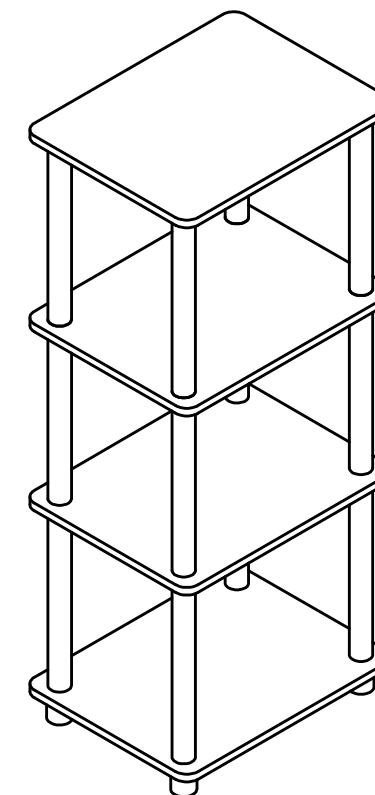

No Tools Required

Assembly Instruction

Turn-N-Tube 3 Space Shelf



HARDWARE & PARTS LIST

NO	PARTS LIST	QTY	NO	HARDWARE	QTY
A	TOP PANEL 	1pc	1	ROUND LONG POLE 	12pcs
B	SHELF PANEL 	3pcs	2	ROUND LEG 	4pcs

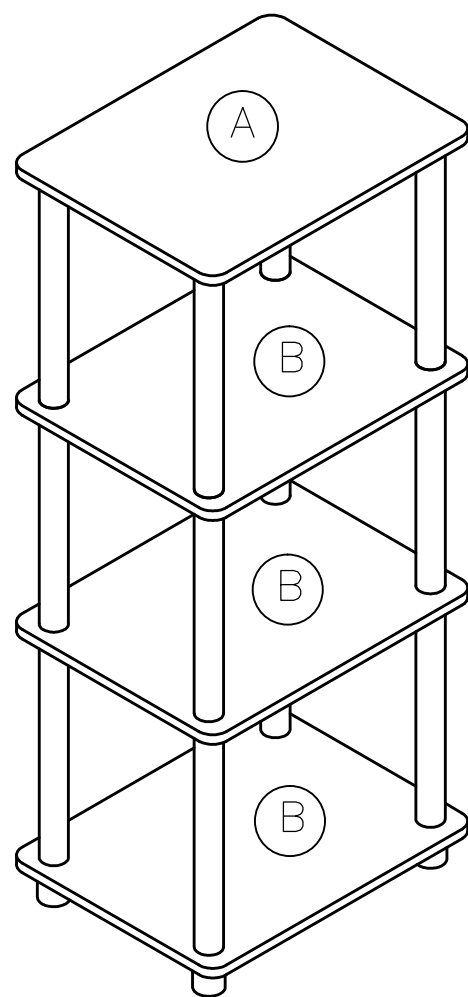

USEFUL HINTS BEFORE YOU START:

1. Read each step carefully before starting.
2. It is important that each step is performed in correct order to avoid difficulties.
3. Identify, sort and count the parts before assembly.
4. Assemble your furniture on packaging cardboard to prevent scratch or damage.
5. Clean the product with mild cleanser using soft dampened cloth. Do not use harsh or abrasive cleanser.
6. Using incompatible hardware might cause damage to product.

ASSEMBLY INSTRUCTIONS

BEFORE YOU BEGIN, PLEASE READ ASSEMBLY INSTRUCTION CAREFULLY, FOLLOW THEM STEP BY STEP.

STEP 1

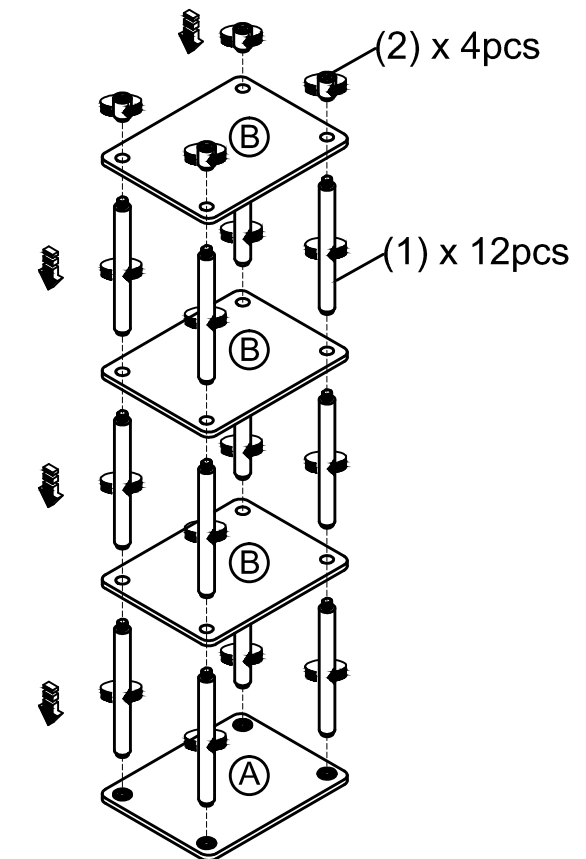

STEP 2

