

King Bed

Assembly Instructions

1 Assembled View

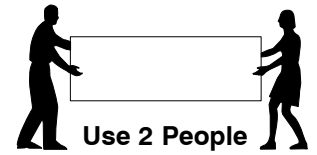
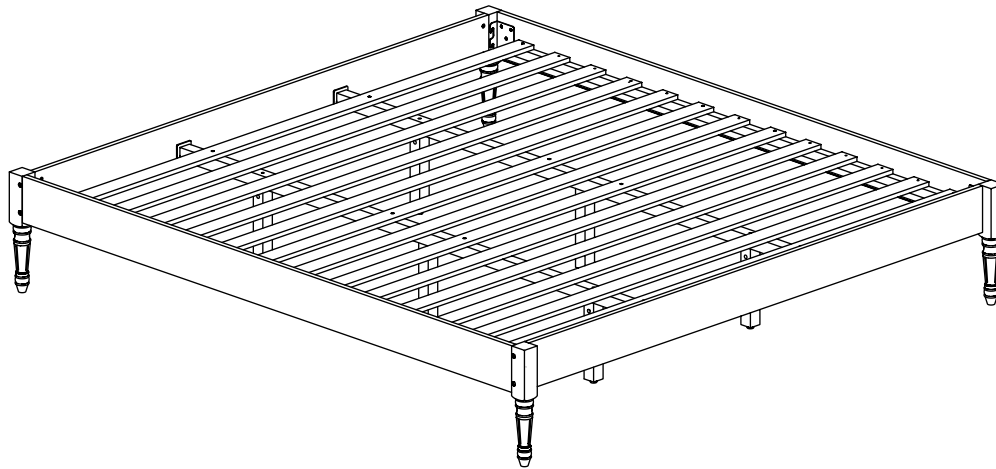

Note: Do not assemble using power tools. This can cause the bolts to be overtightened

2 Parts List

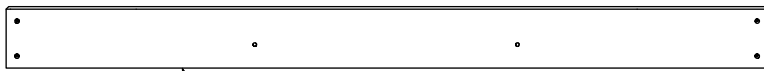

A Head / Footboard Panel x 2

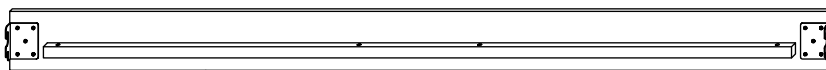

B Side Rail x 2

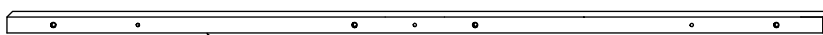

C Long Support x 2



D
Support Leg
x 6

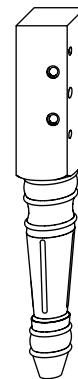

E
Post
(Left hand)
x 2

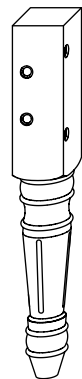

F
Post
(Right hand)
x 2

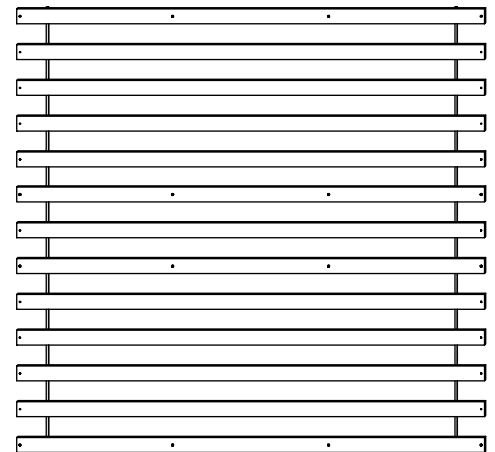

G Set of Bed Slats x 1

King Bed

Assembly Instructions

3 Hardware List



1 M4 Allen Key
x 1

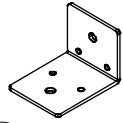

2 Center Rail Bracket
x 4

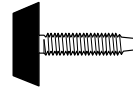

3 Adjustable Foot
x 6

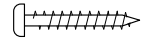

4 Wood Screw (M4 x 32mm)
x 18



5 Wood Dowel (10 x 40mm)
x 4



6 Barrel Nut
x 14



7 Spring Washer
x 8



8 Flat Washer
x 8



9 M6 x 15mm JCB
x 8



10 M6 x 20mm JCB
x 8



11 M6 x 40mm JCB
x 16



12 M6 x 90mm JCB
x 14

4 Assembled the Support Leg (D) to the Long Support (C).

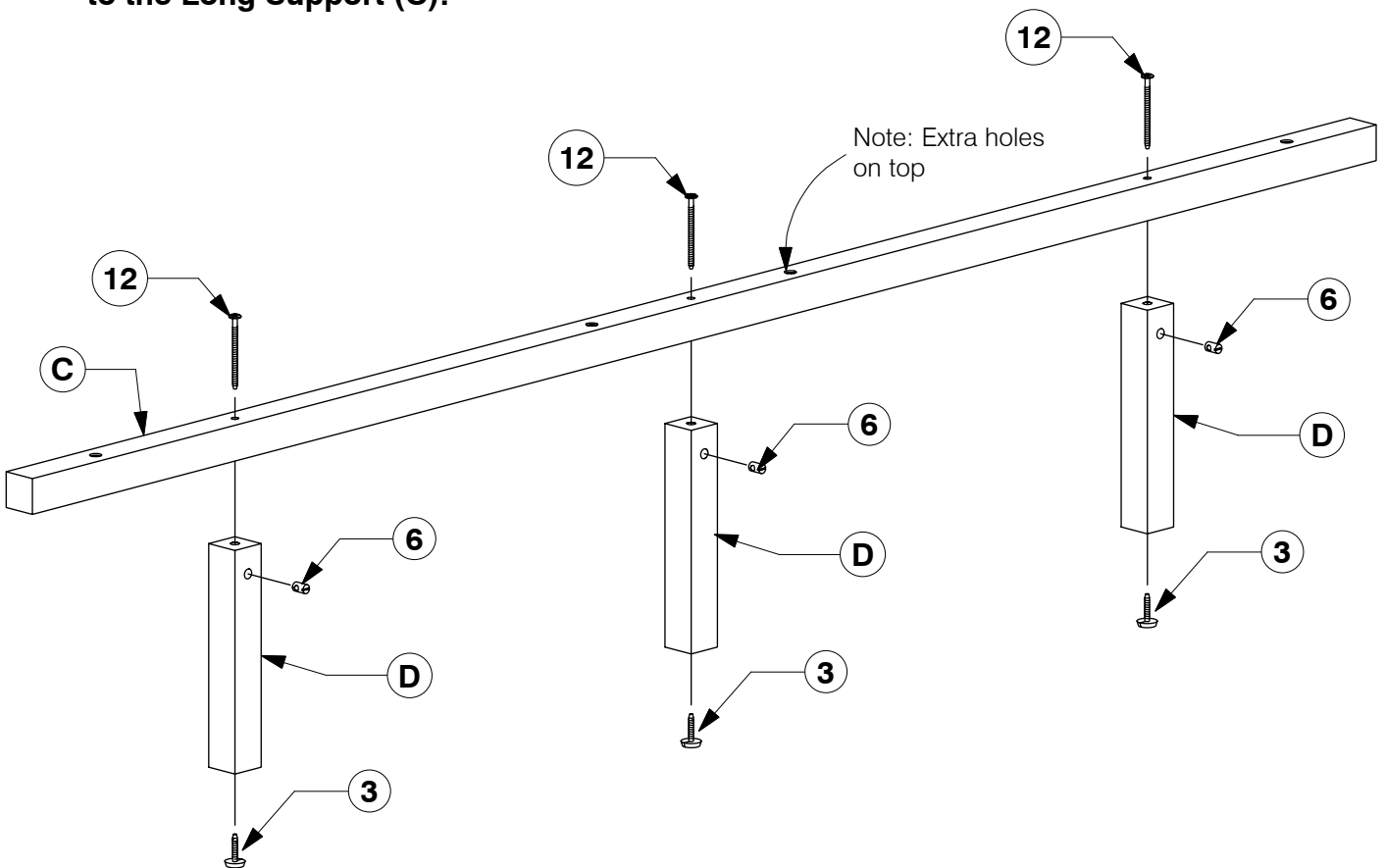

King Bed

Assembly Instructions

- 5** Assemble the Post (E & F) to the Head / Footboard Panel (A).
Fit the Center Rail Bracket to the Head / Footboard Panel (A).

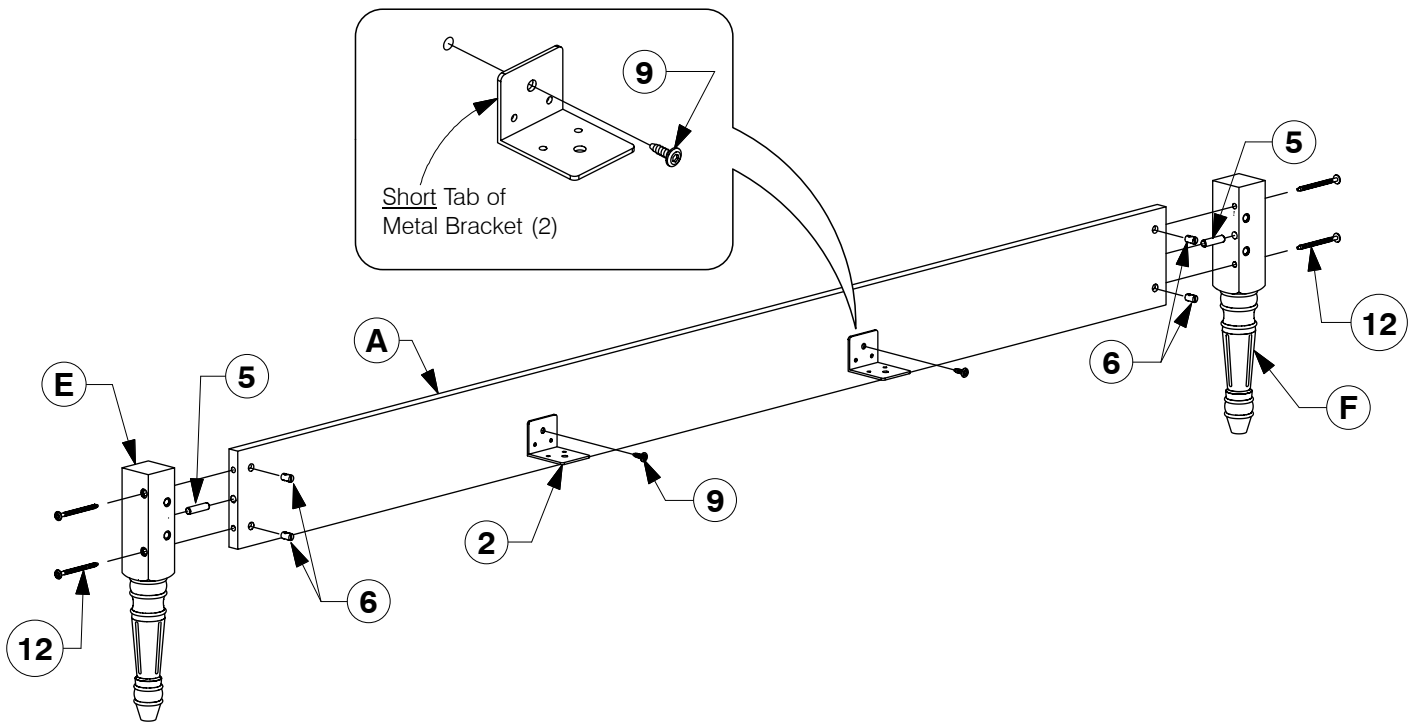

- 6** Assemble the Side Rail (B) to the Headboard / Footboard Panel (A).

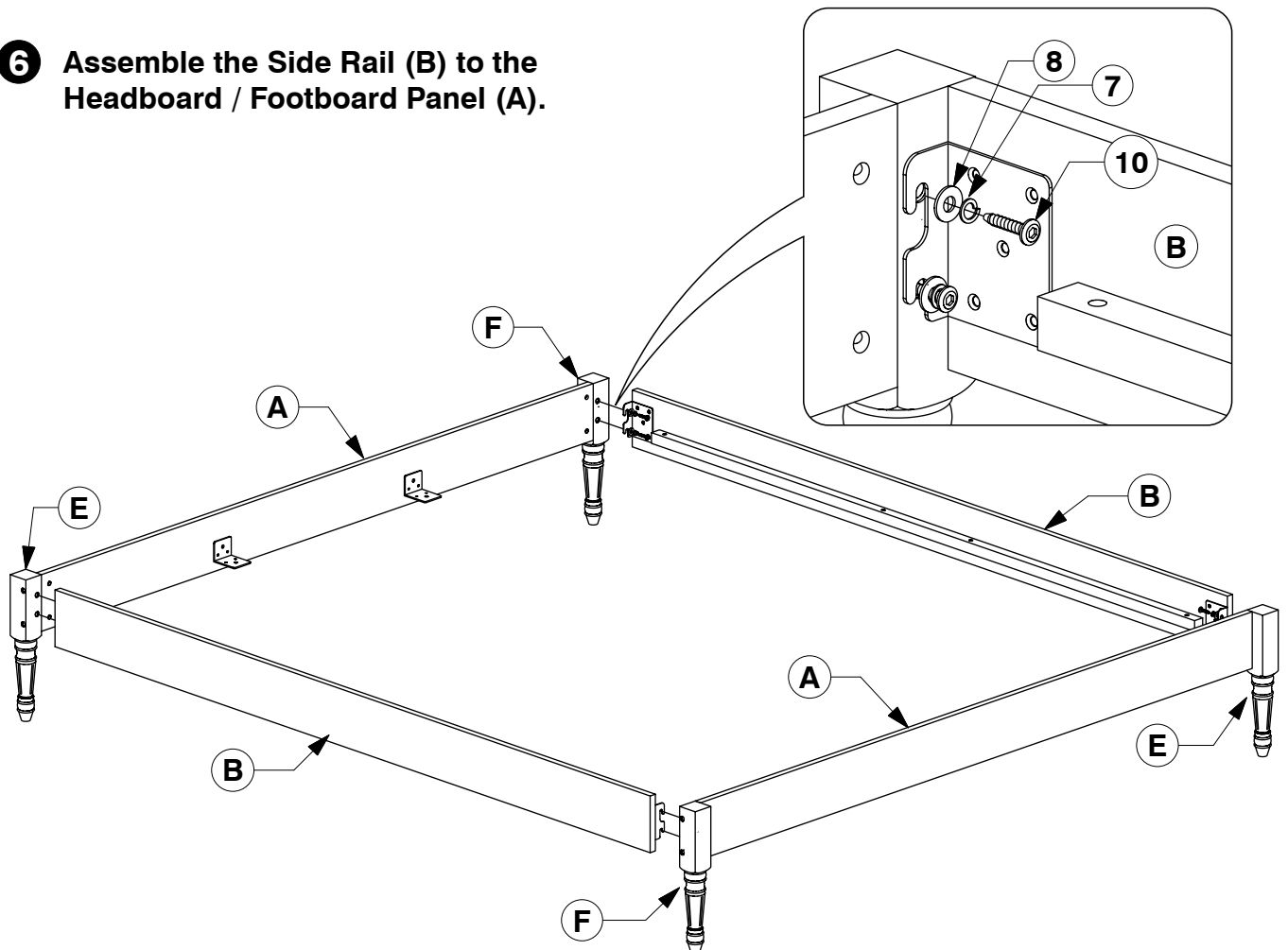

King Bed

Assembly Instructions

- 7 Bolt the Long Support (C) to the Center Rail Brackets (2) on the Headboard / Footboard Panel (A).**

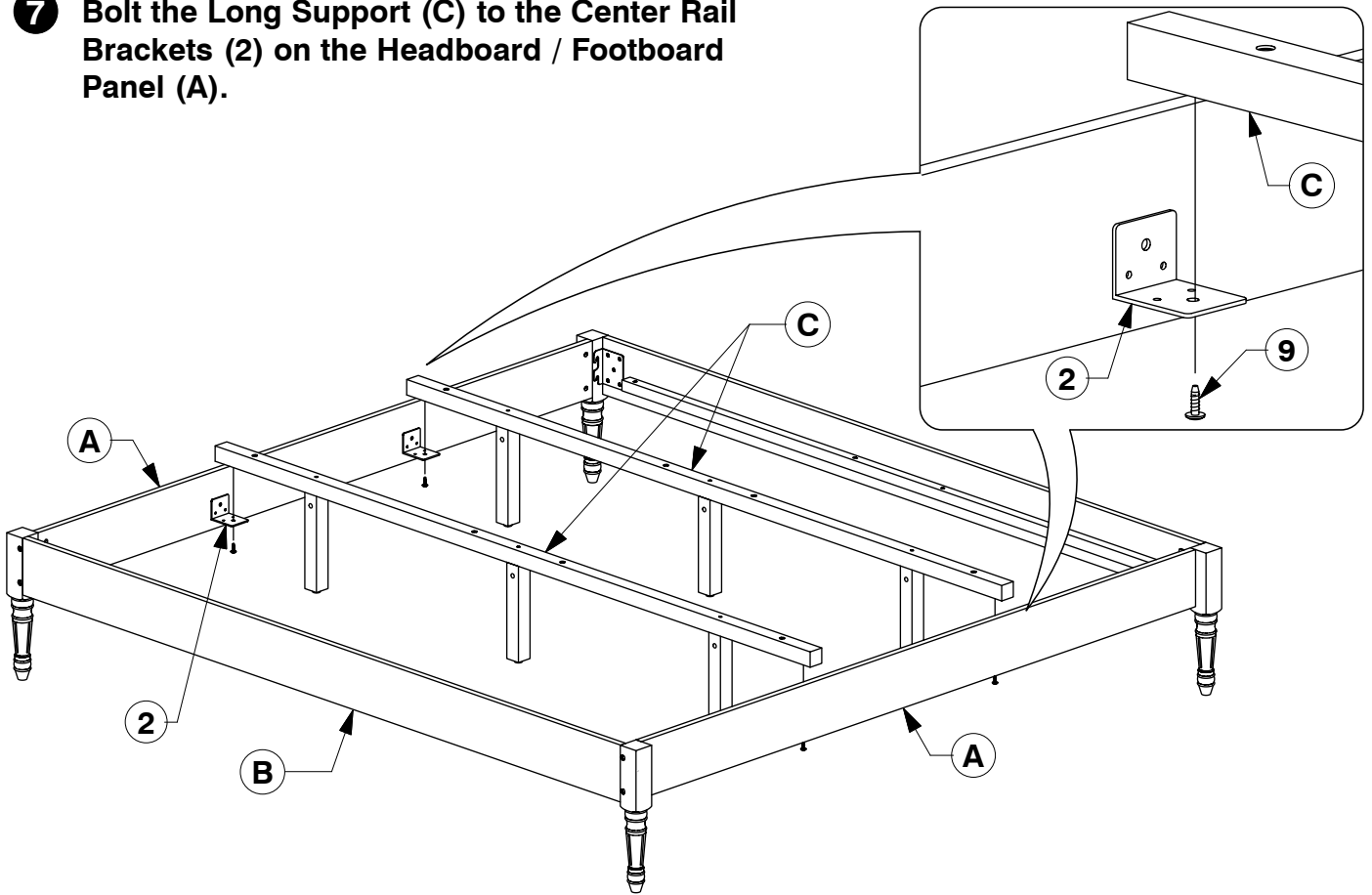

- 8 Bolt & screw the Bed Slats (G) to the Side Rail (B).**

