

Assembly Instructions

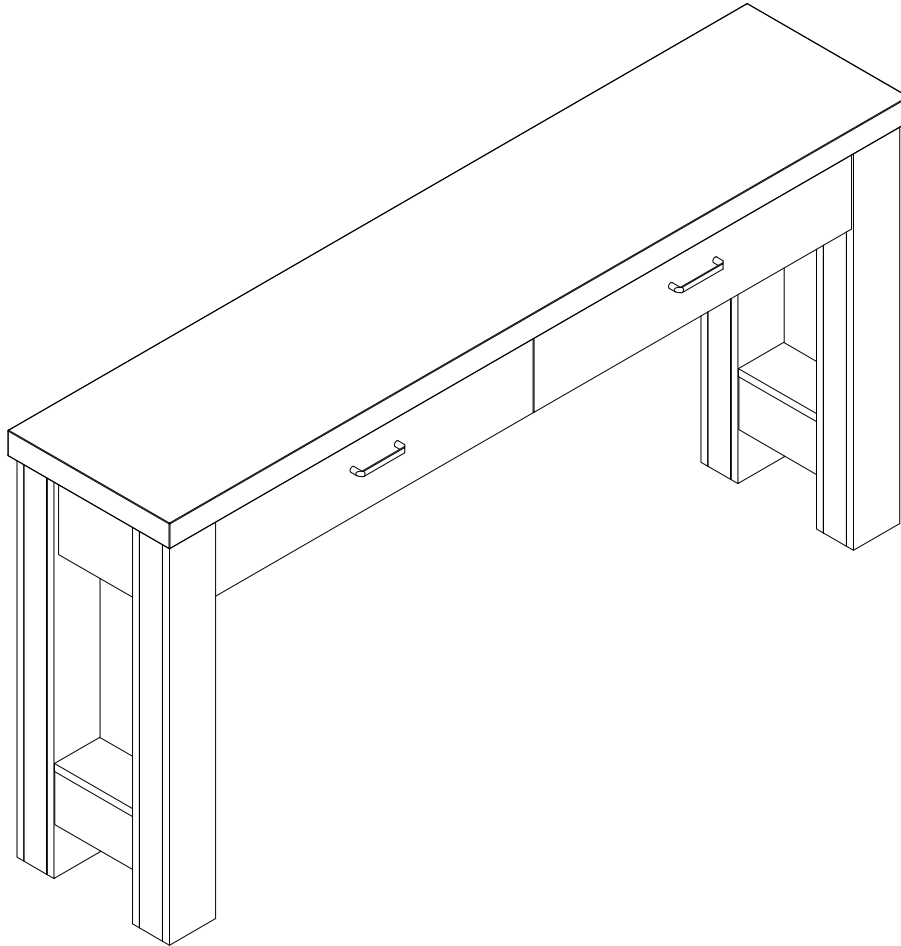

Warm Tips

1. Carefully read these instructions and keep them for future reference.
2. Check the parts list and confirm everything's there before starting assembly.
3. When assembling, put all parts on a soft, smooth surface like a carpet to avoid scratches.
4. Don't fully tighten screws until all parts are confirmed in place to avoid misalignment.

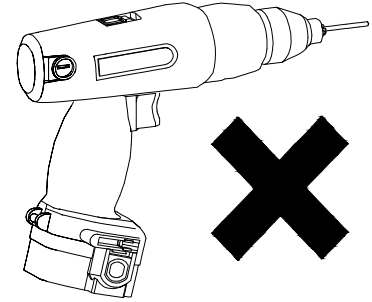
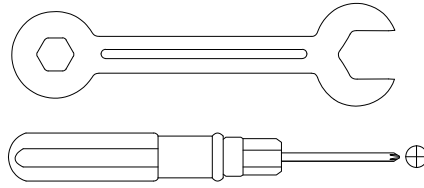
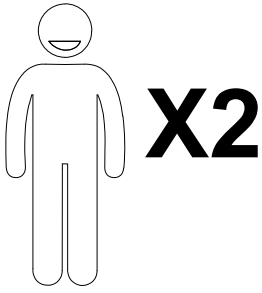

We recommend using hand tools for assembly.

If an electric screwdriver is used, reduce power and torque to avoid damage to the product.

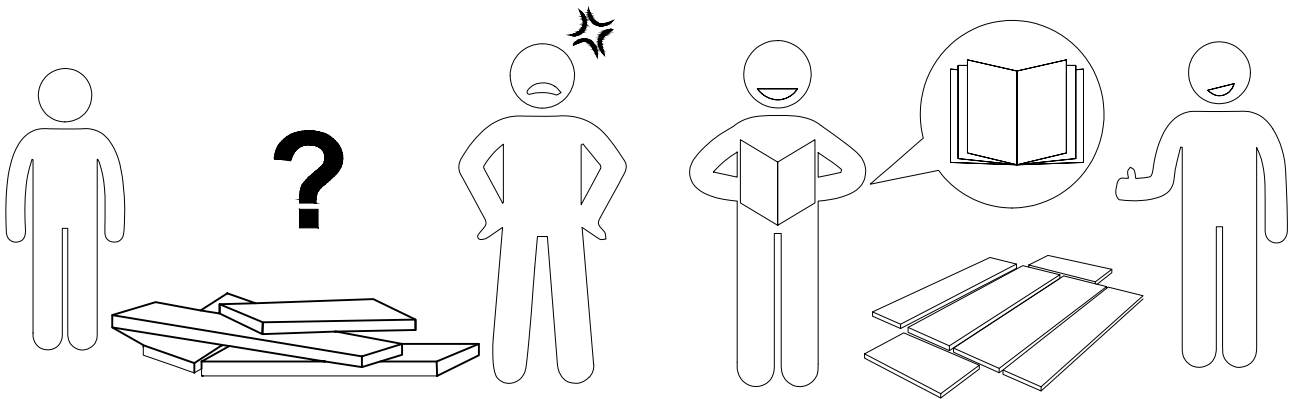

Install the Anti-Tip Straps

Using the anti-tip straps can reduce the risk of tipping over, but can not eliminate it.

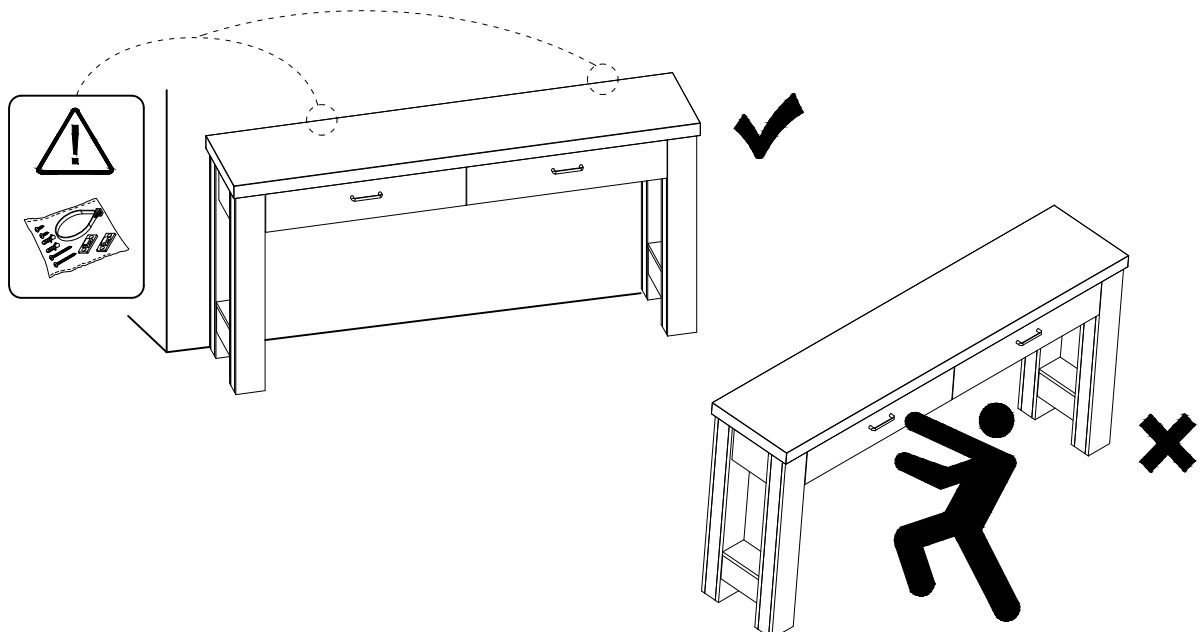

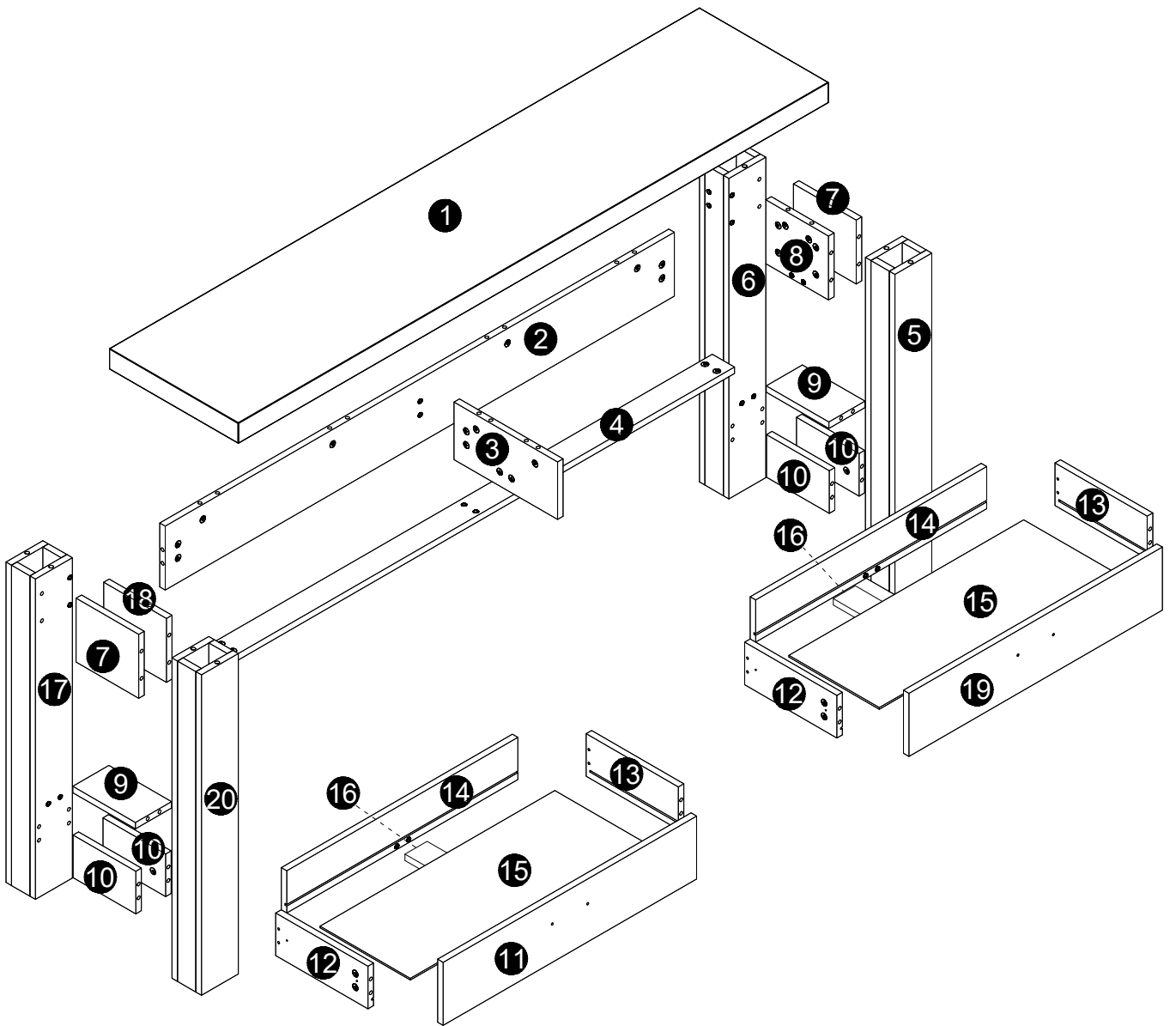





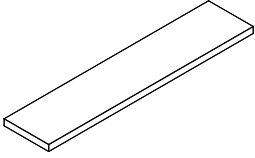
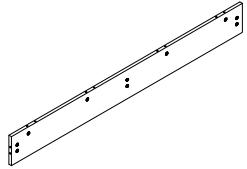
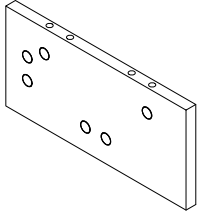
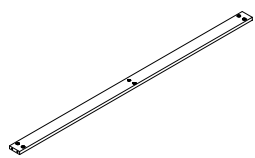

⚠ Caution

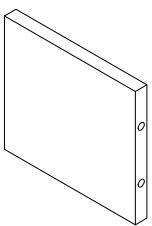
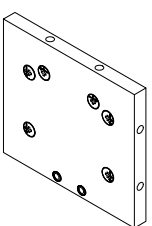
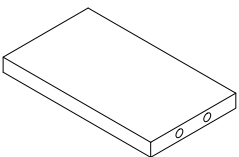
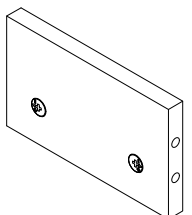
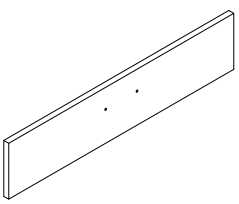
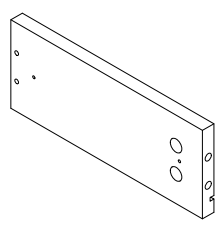
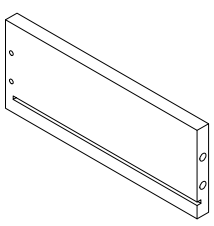
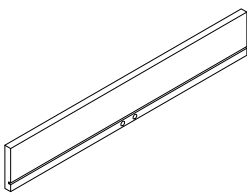
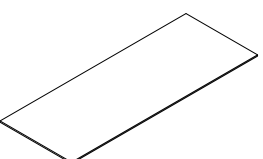
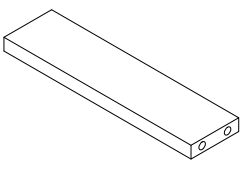
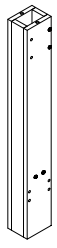
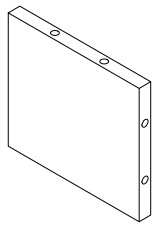
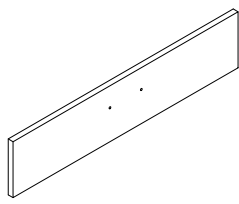

Make sure all parts are included. Most board parts are labeled or stamped on the raw edge. Contact us for a free replacement if you encounter any damaged or missing parts.

Parts List

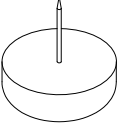
<p>1</p>  <p>1 pc</p>	<p>2</p>  <p>1 pc</p>	<p>3</p>  <p>1 pc</p>	<p>4</p>  <p>1 pc</p>	<p>5</p>  <p>1 pc</p>
<p>6</p>  <p>1 pc</p>	<p>7</p>  <p>2 pcs</p>	<p>8</p>  <p>1 pc</p>	<p>9</p>  <p>2 pcs</p>	<p>10</p>  <p>4 pcs</p>
<p>11</p>  <p>1 pc</p>	<p>12</p>  <p>2 pcs</p>	<p>13</p>  <p>2 pcs</p>	<p>14</p>  <p>2 pcs</p>	<p>15</p>  <p>2 pcs</p>
<p>16</p>  <p>2 pcs</p>	<p>17</p>  <p>1 pc</p>	<p>18</p>  <p>1 pc</p>	<p>19</p>  <p>1 pc</p>	<p>20</p>  <p>1 pc</p>

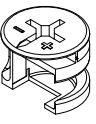
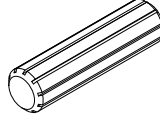
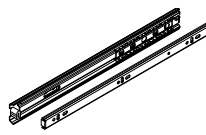
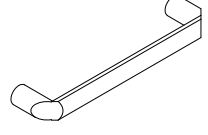
Hardware List

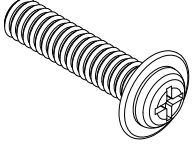
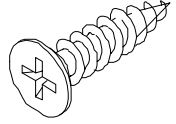
A	B	C	D	E	F
					
Ø12*5mm	Ø6*45mm	Ø15*12mm	Ø8*40mm	250mm	96mm
16 pcs	62 pcs	62 pcs	22 pcs	2 stes	2 pcs

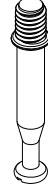
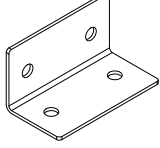
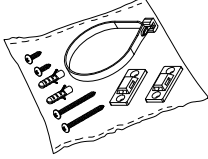
G	H	I	J	K	L
					
M4*18	4*30mm	3.5*15mm	Ø6*30mm	20*20*38mm	
4 pcs	8 pcs	24 pcs	8 pcs	2 pcs	2 pcs

Installation of Cams and Pins

Read each step carefully before starting. Each step of instruction should be performed in the correct order. If these steps are not followed in sequence, assembly difficulties may occur.

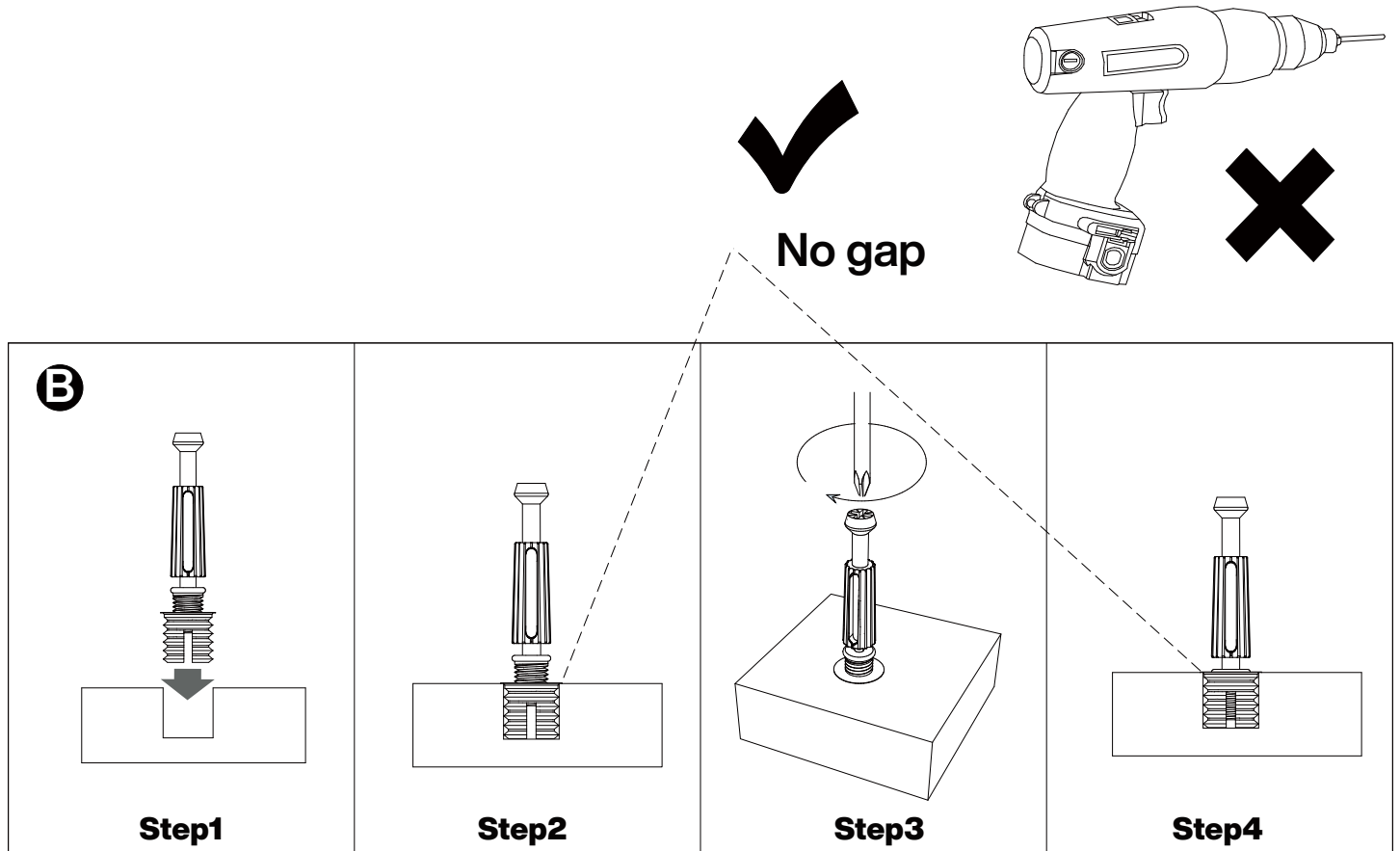

Screw the pin into the hole. Set the cams correctly by aligning the head of the cams with the lock pins. Lock the cam by turning the cam head with a screwdriver until it is tightened. Please do not use an electric screwdriver to assemble the unit.

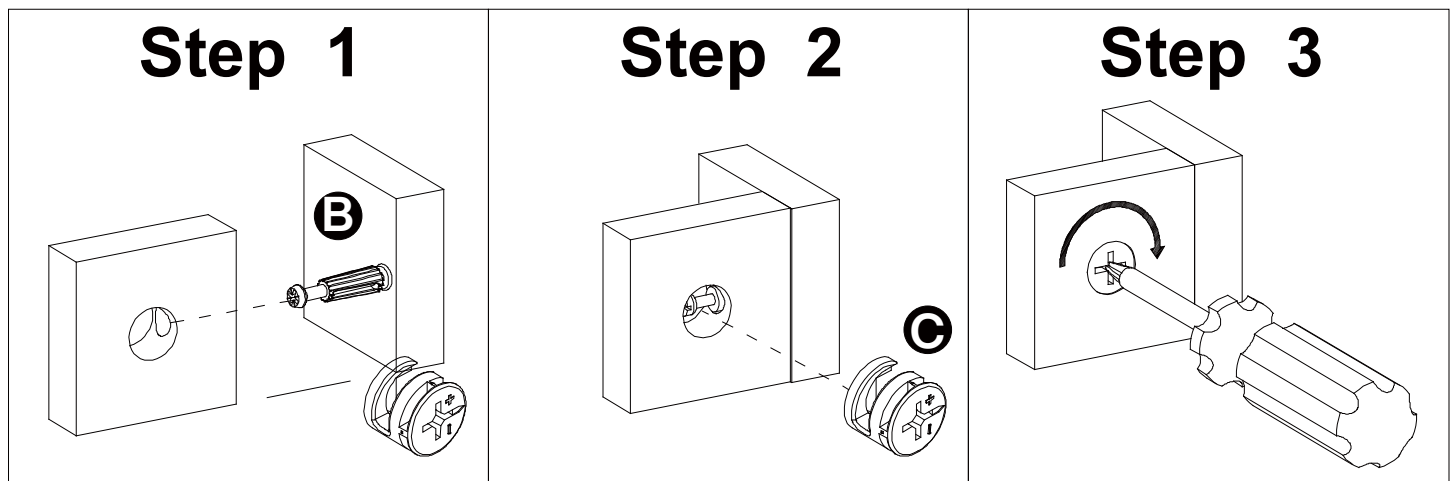

Please split component "E" into "E-1" and "E-2" before assembling the slide and then proceed to the next step of assembly

Step 1

Pull apart component "E" to each side, and then gently push up the lever of component "E-2"

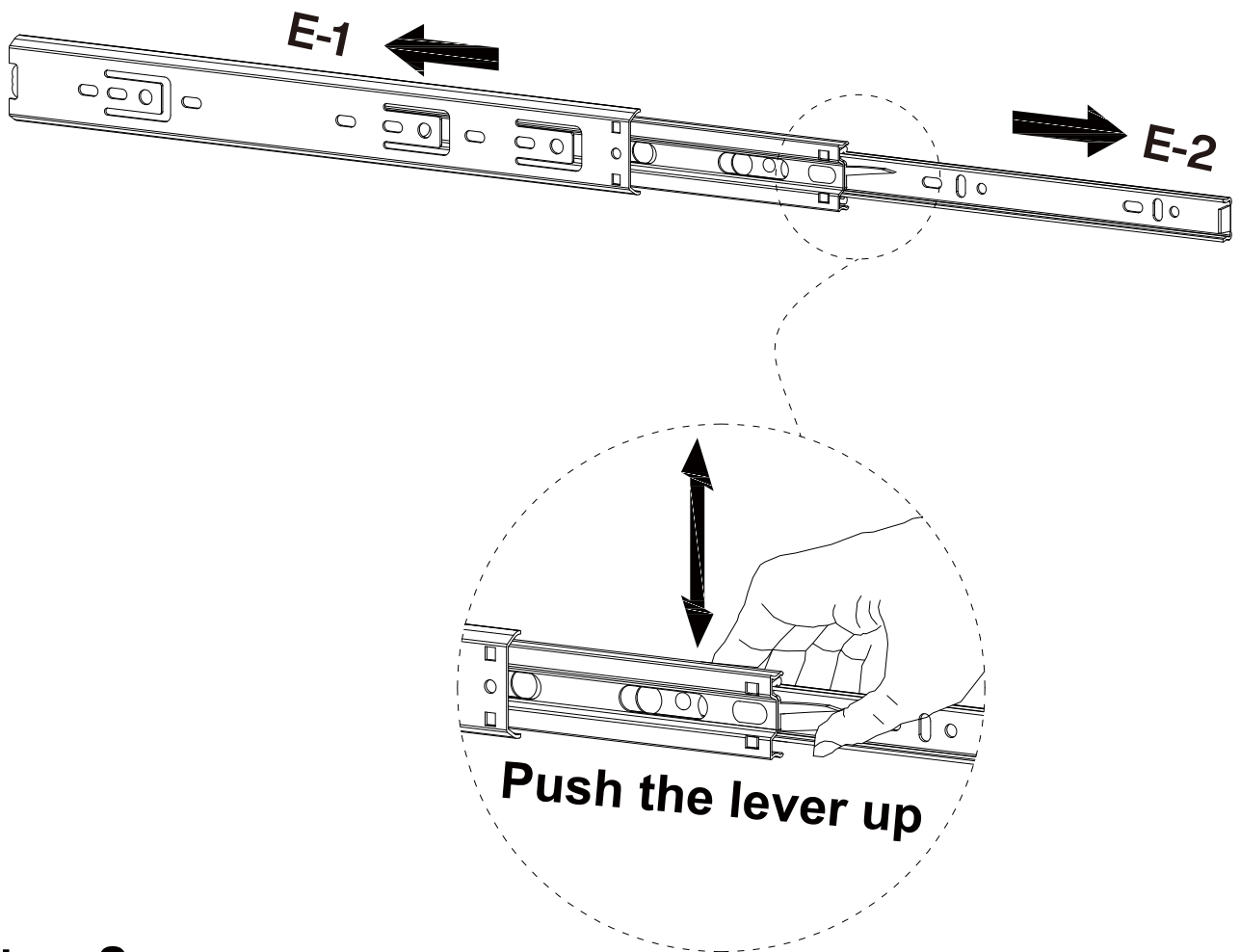

Step 2 Split component "E-1" and "E-2"

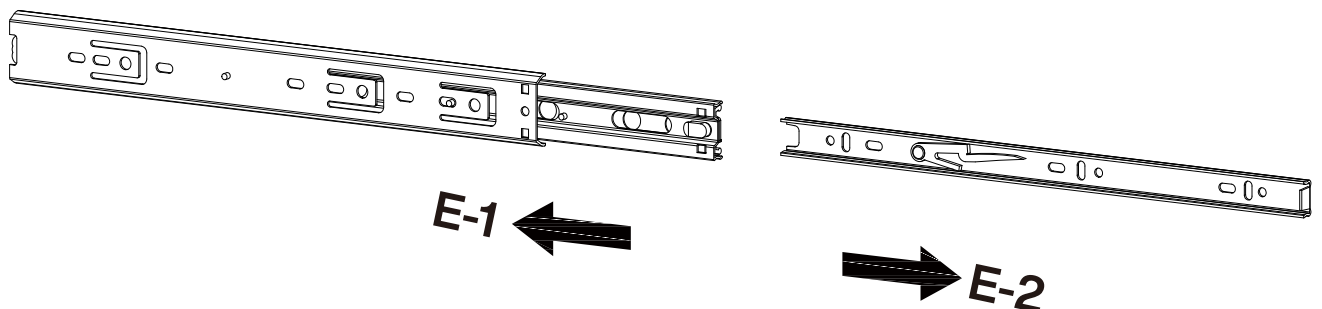

1

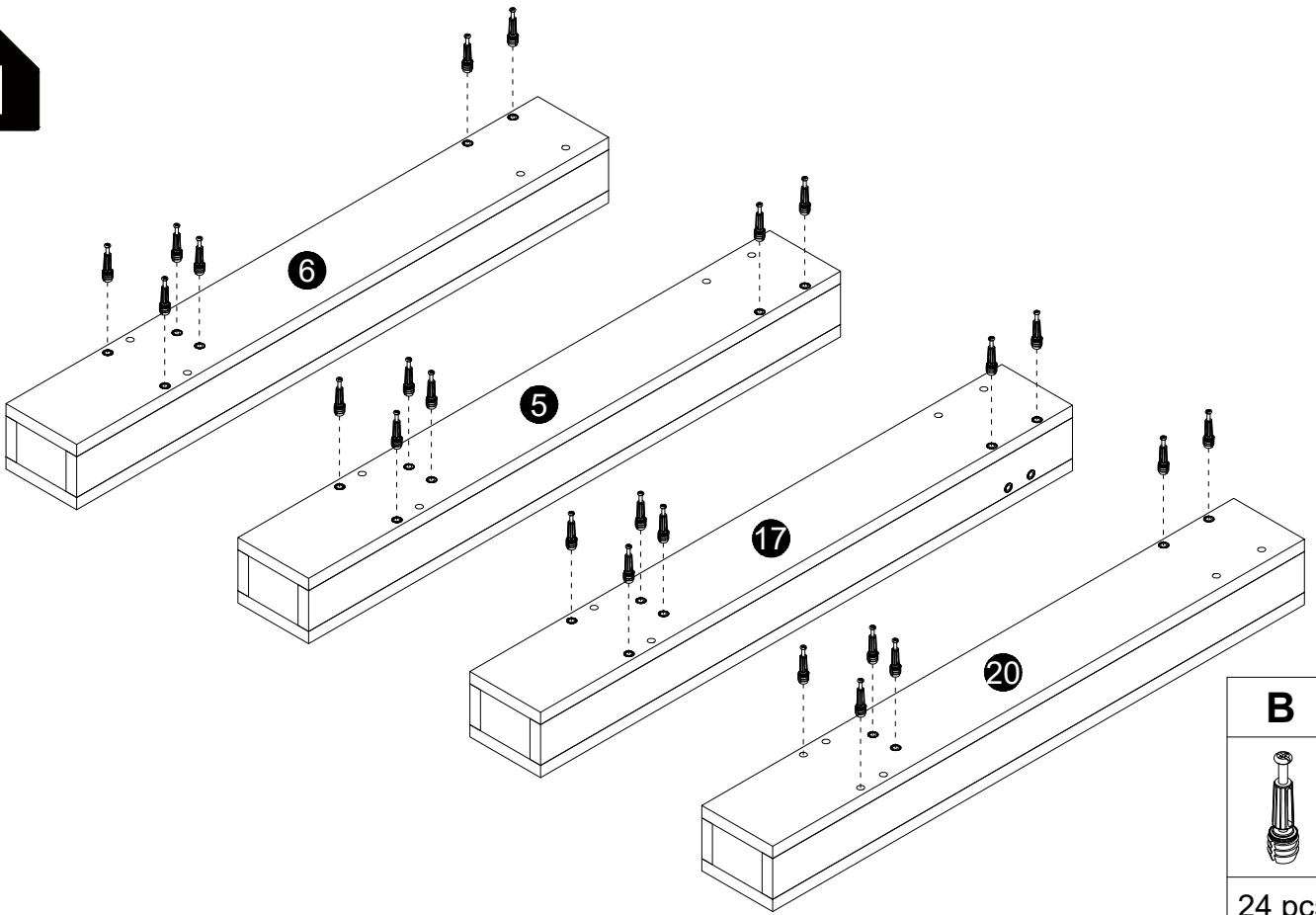

2

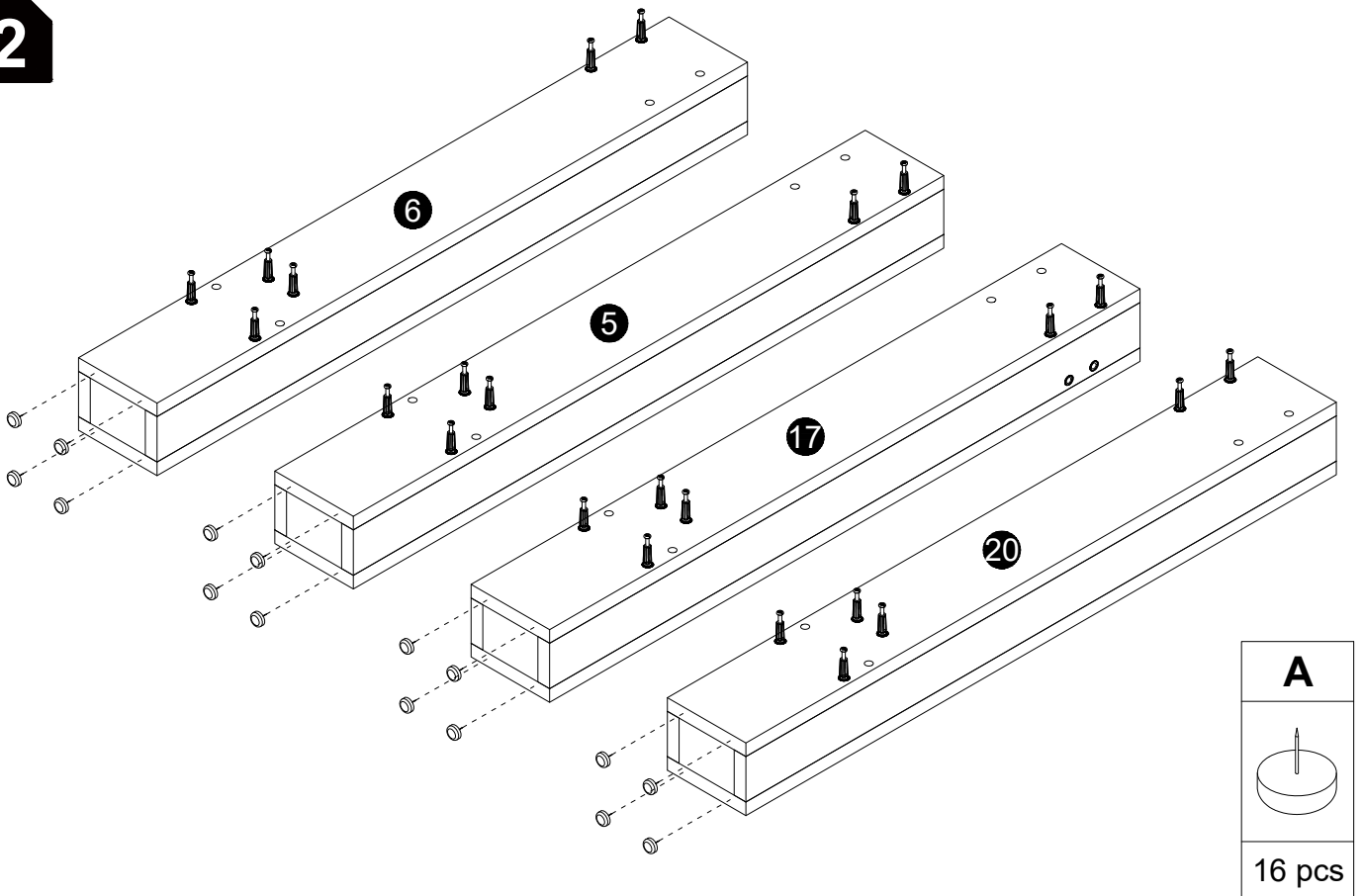

3

Step 1

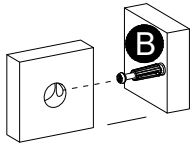

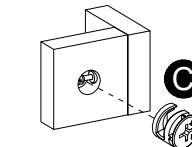

Step 2

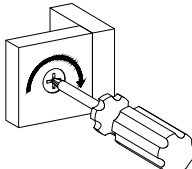
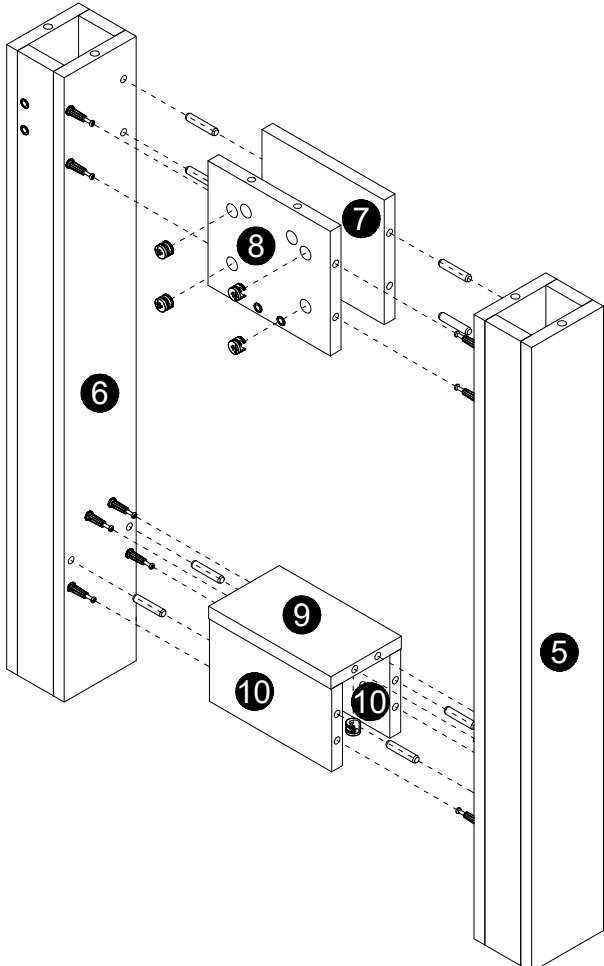

Step 3

C	D
	
12 pcs	8 pcs

4

Step 1



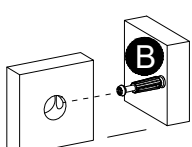

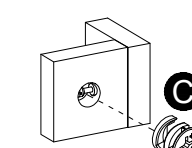
Step 2



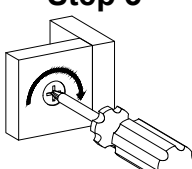
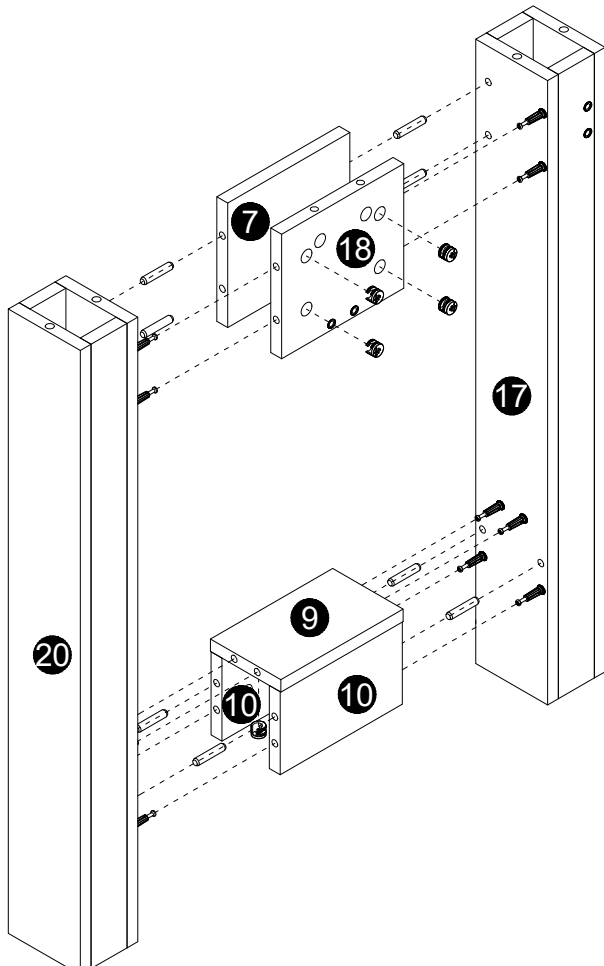

Step 3

C	D
	
12 pcs	8 pcs

5

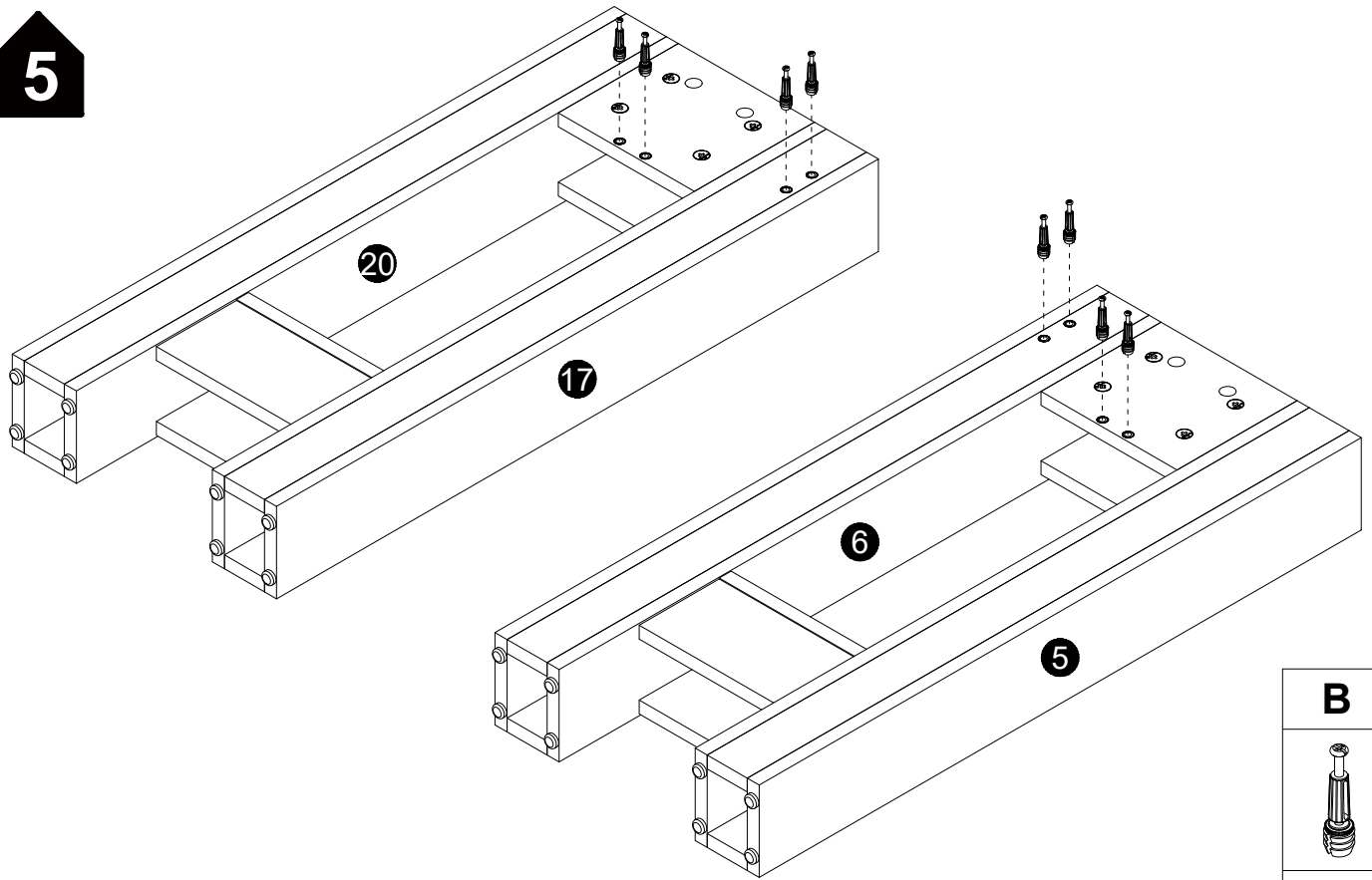

B

8 pcs

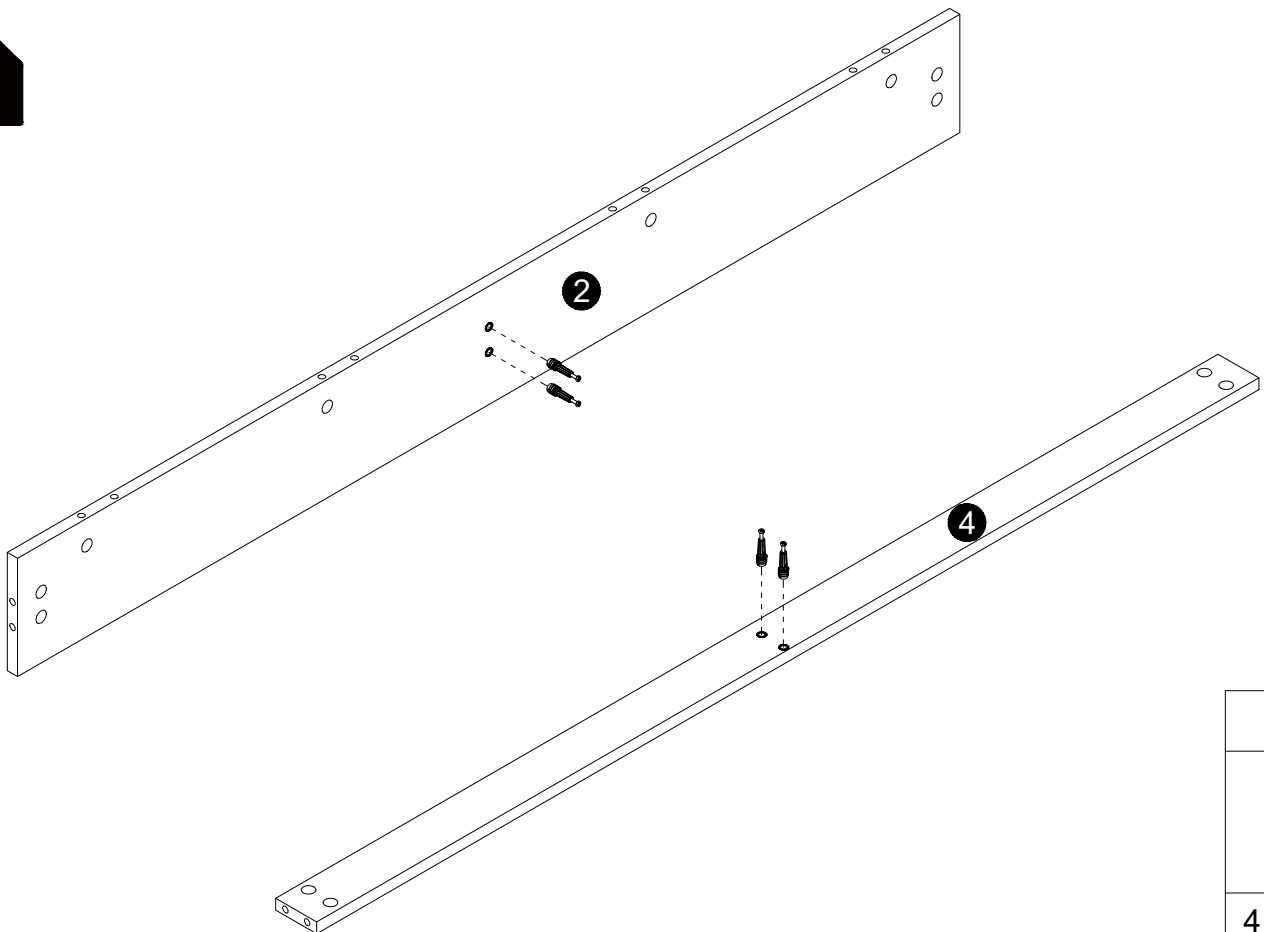
6

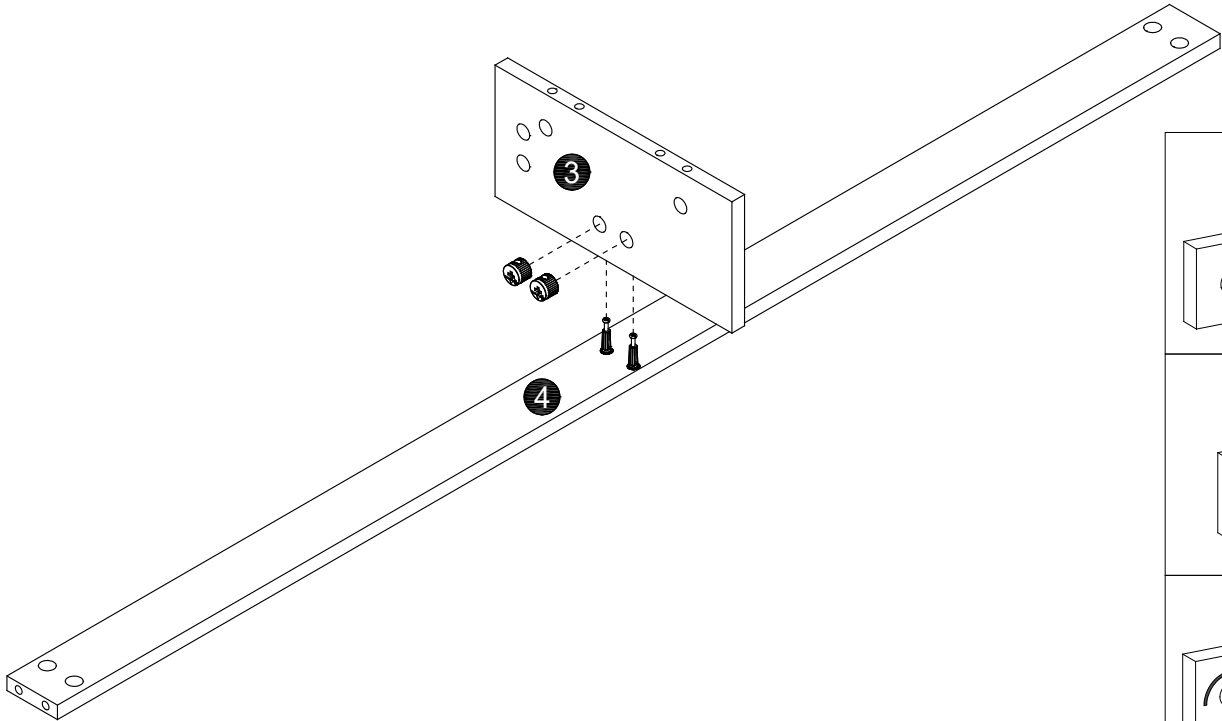

B

4 pcs

7

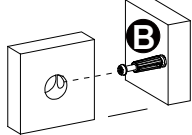
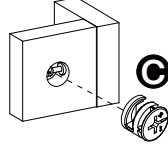
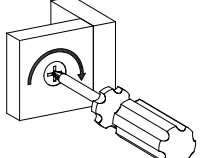

C

2 pcs

Step 1 
Step 2 
Step 3 

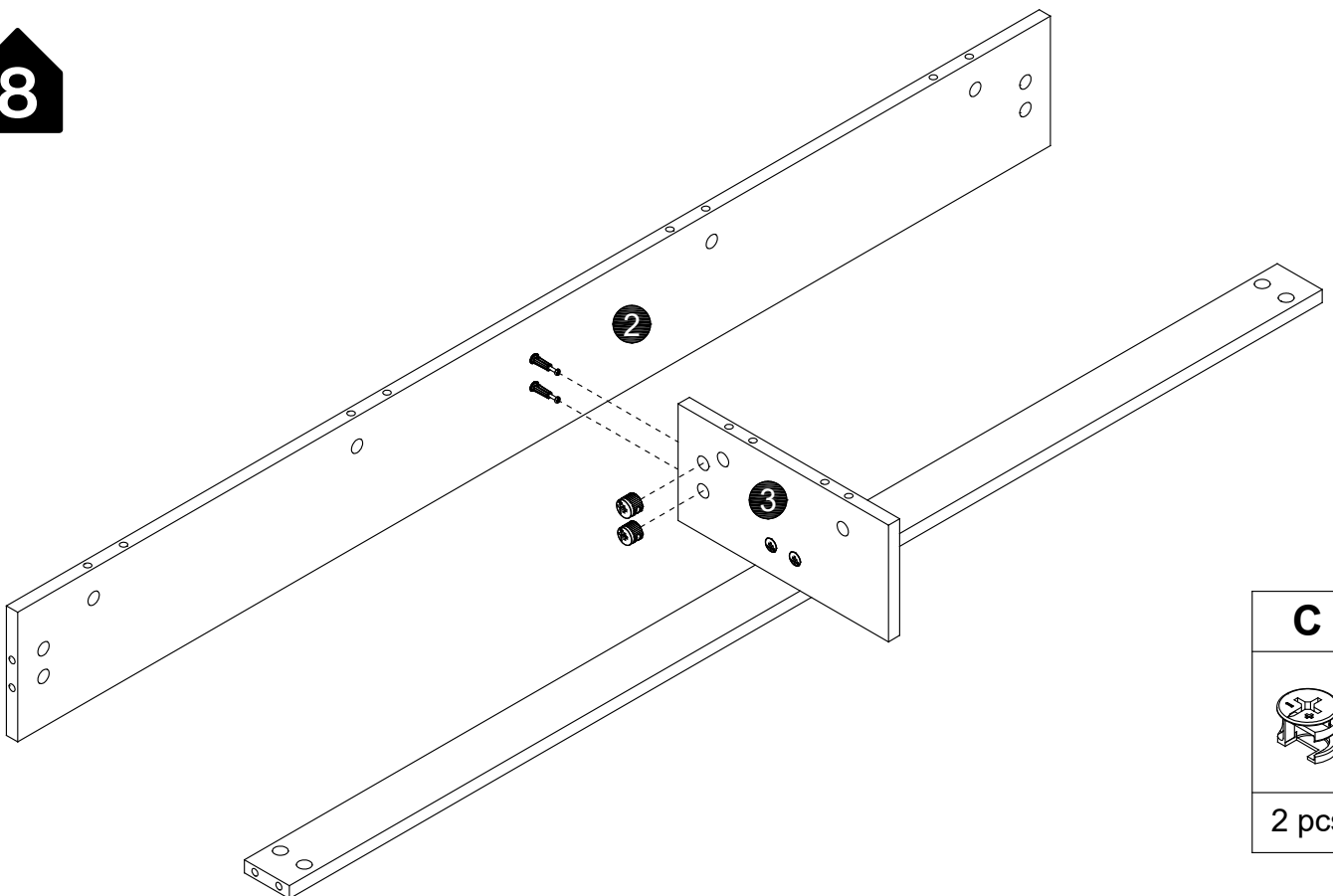
8



C

2 pcs

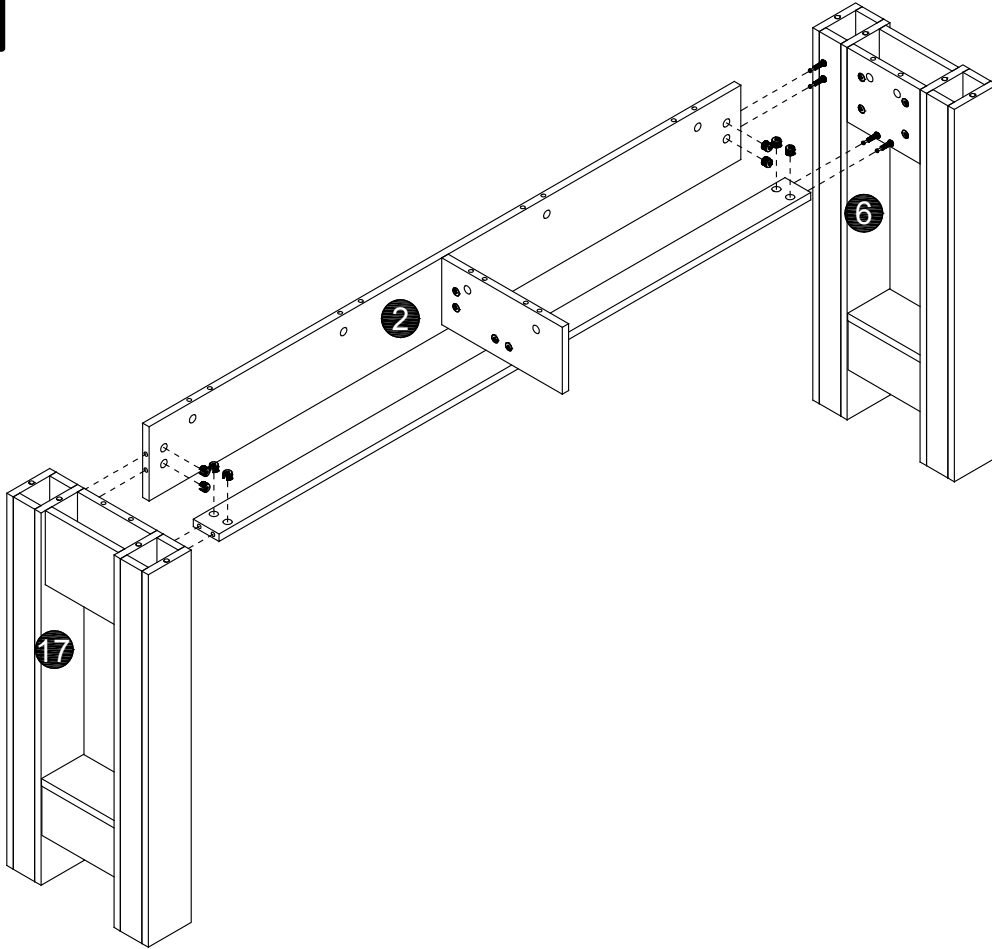
9



C
8 pcs

Step 1
Step 2
Step 3

10

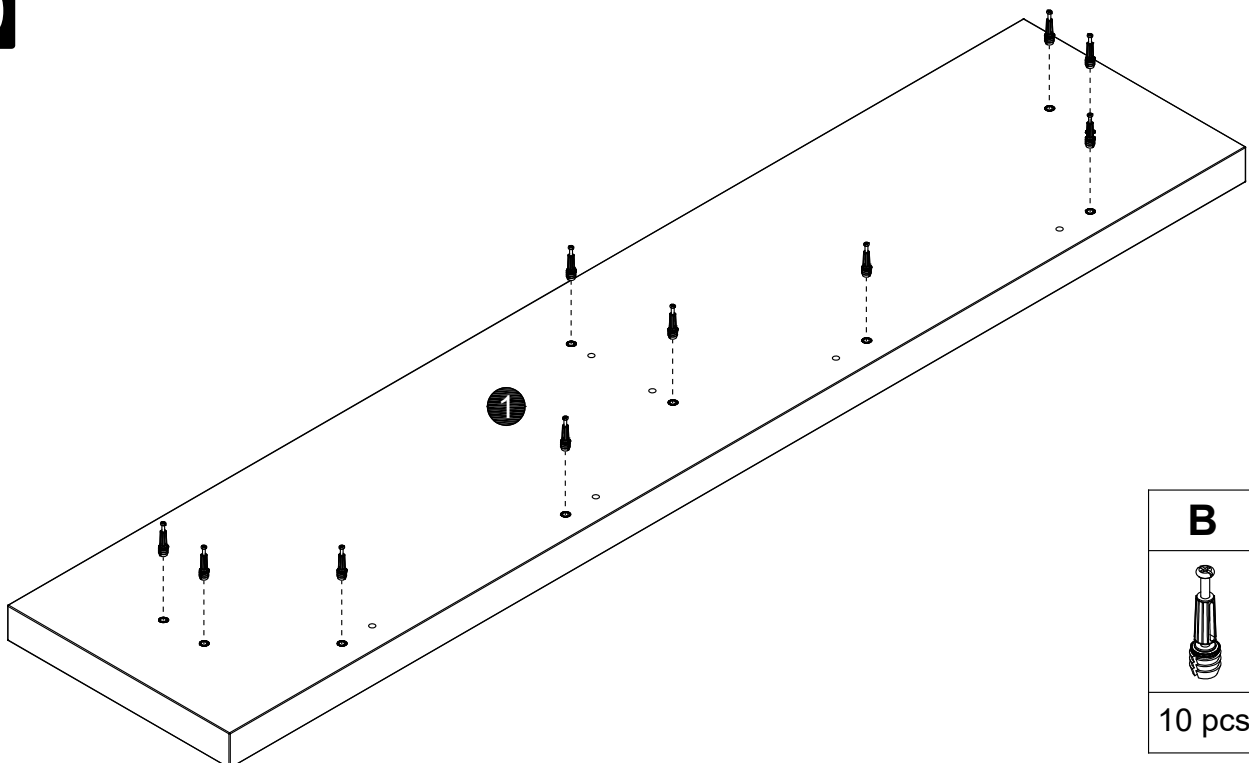

B
10 pcs

11

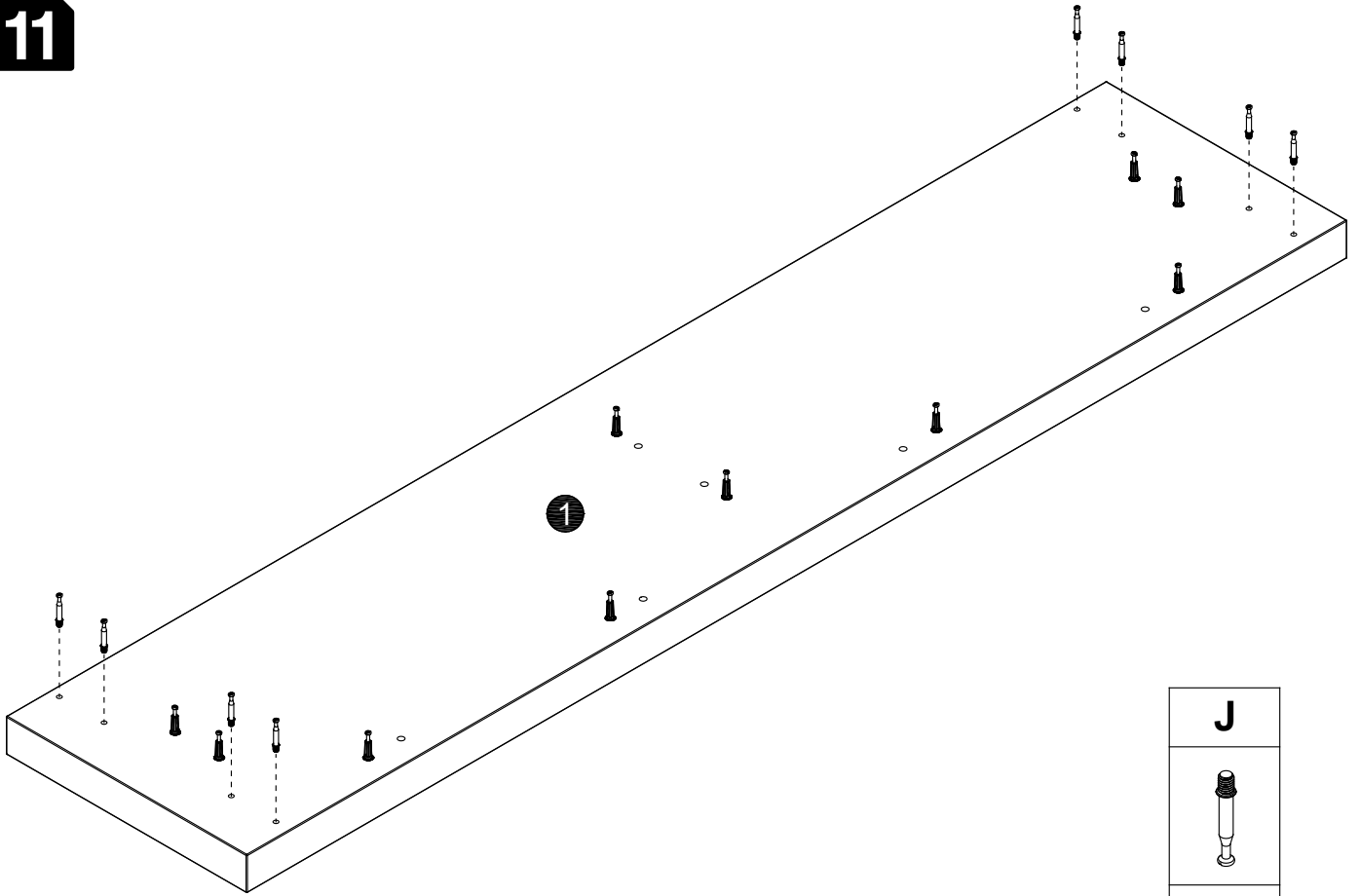

J

8 pcs

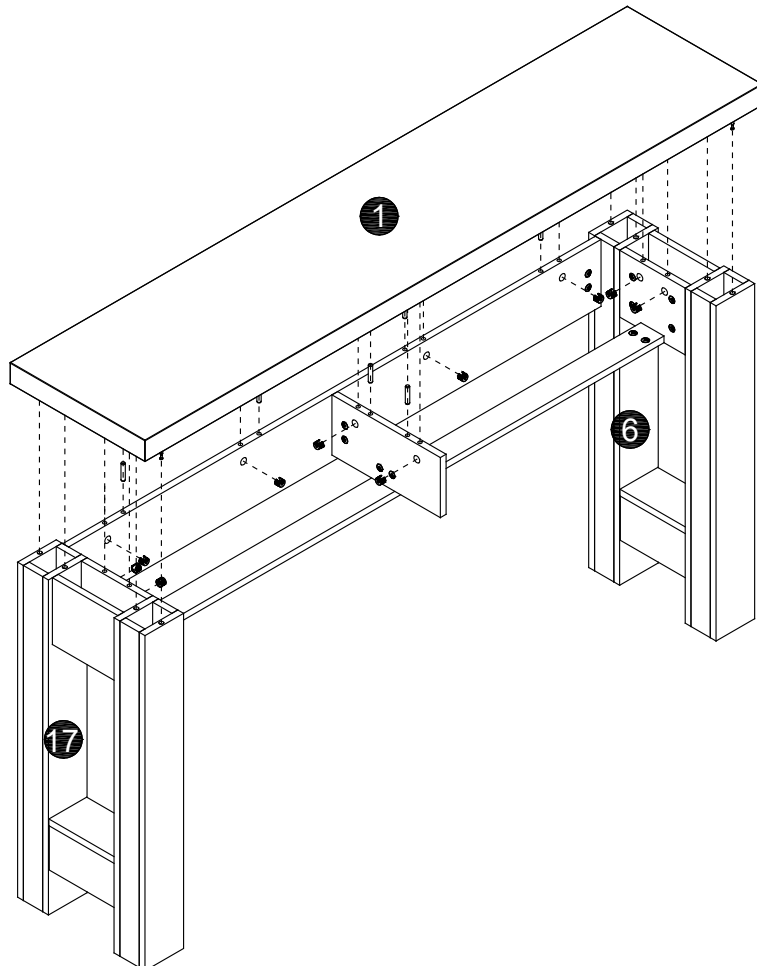
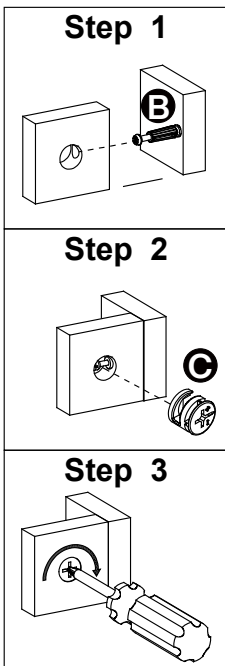

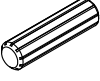
12

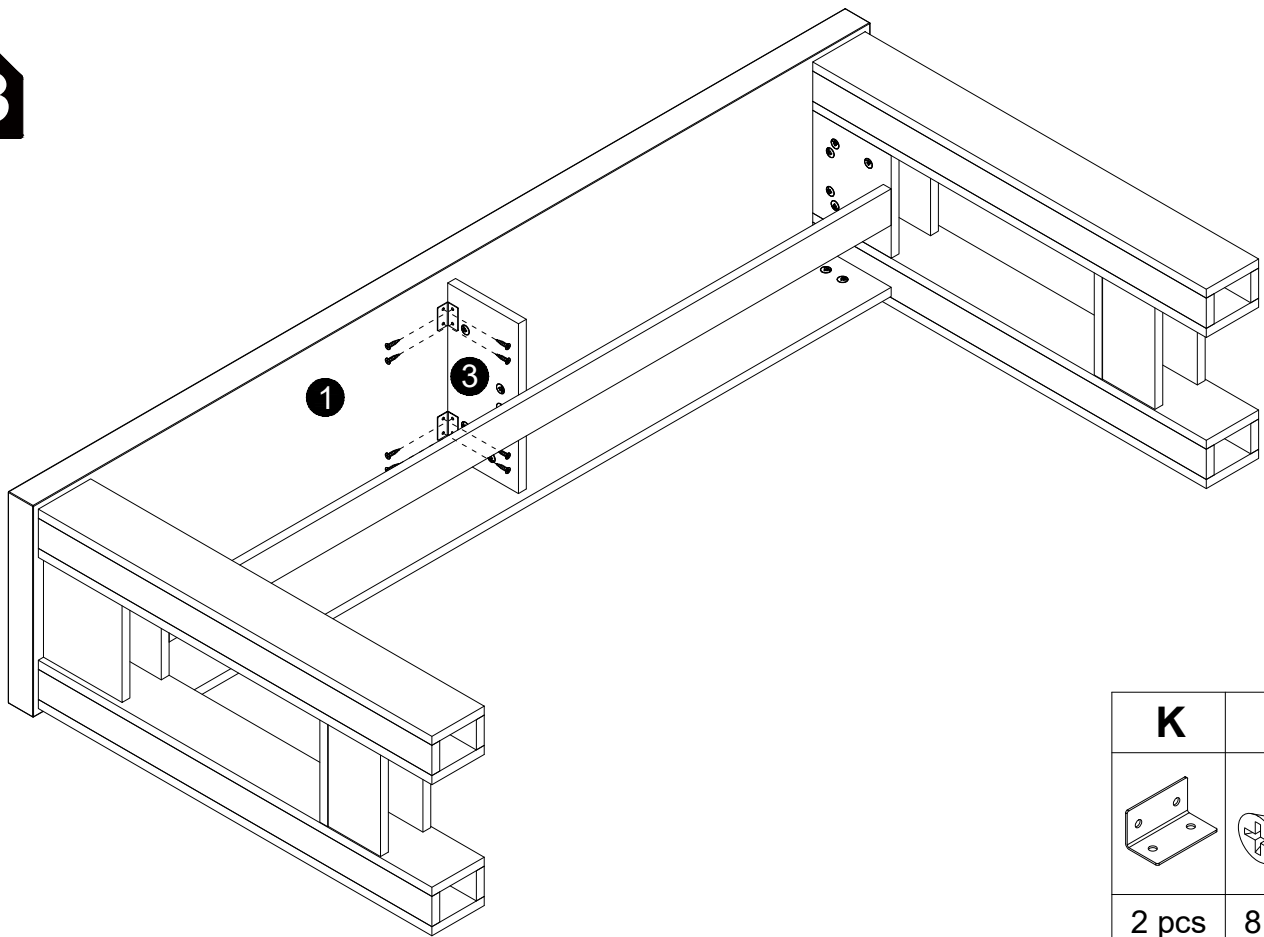

C	D
	
10 pcs	6 pcs

13



K	I
	
2 pcs	8 pcs

14

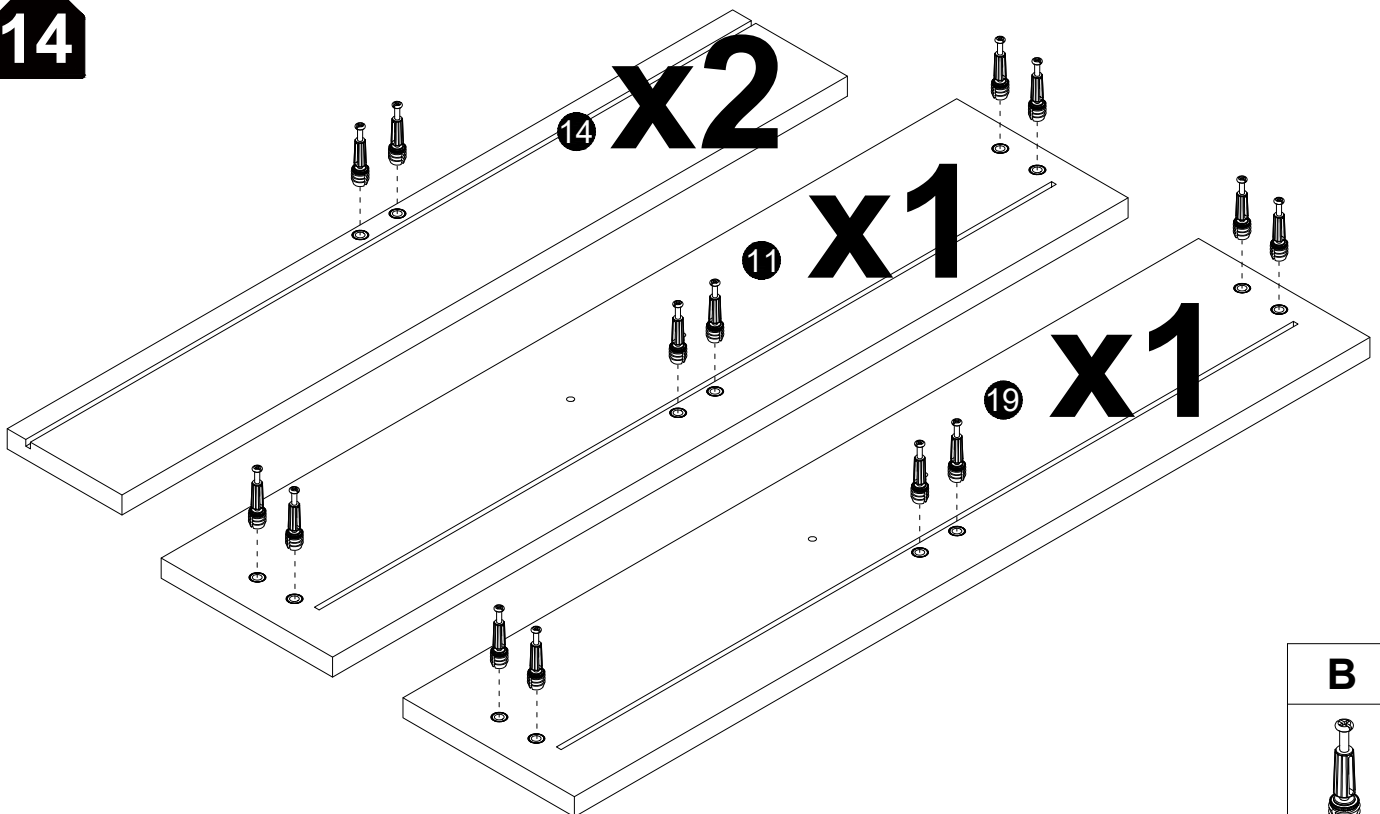

B

16 pcs

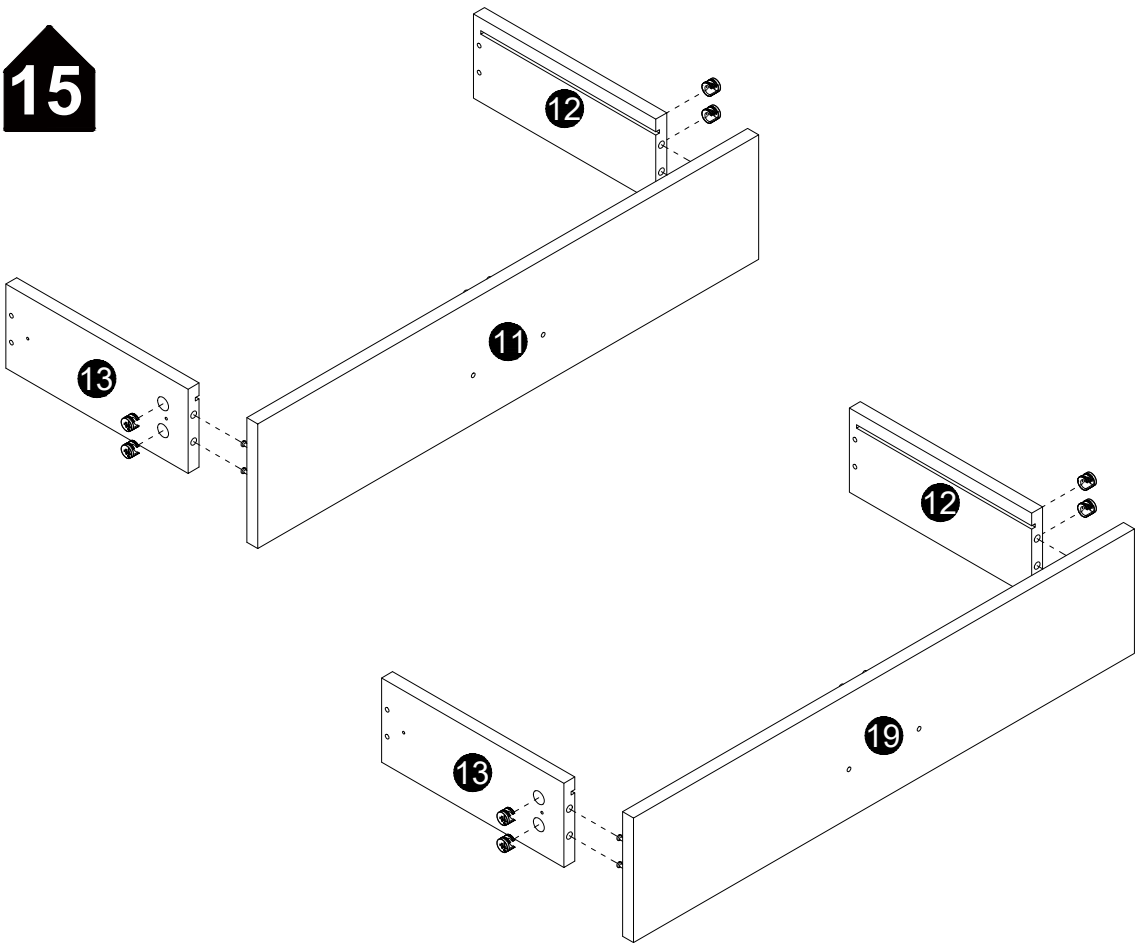
15



C
8 pcs

Step 1

Step 2

Step 3

16

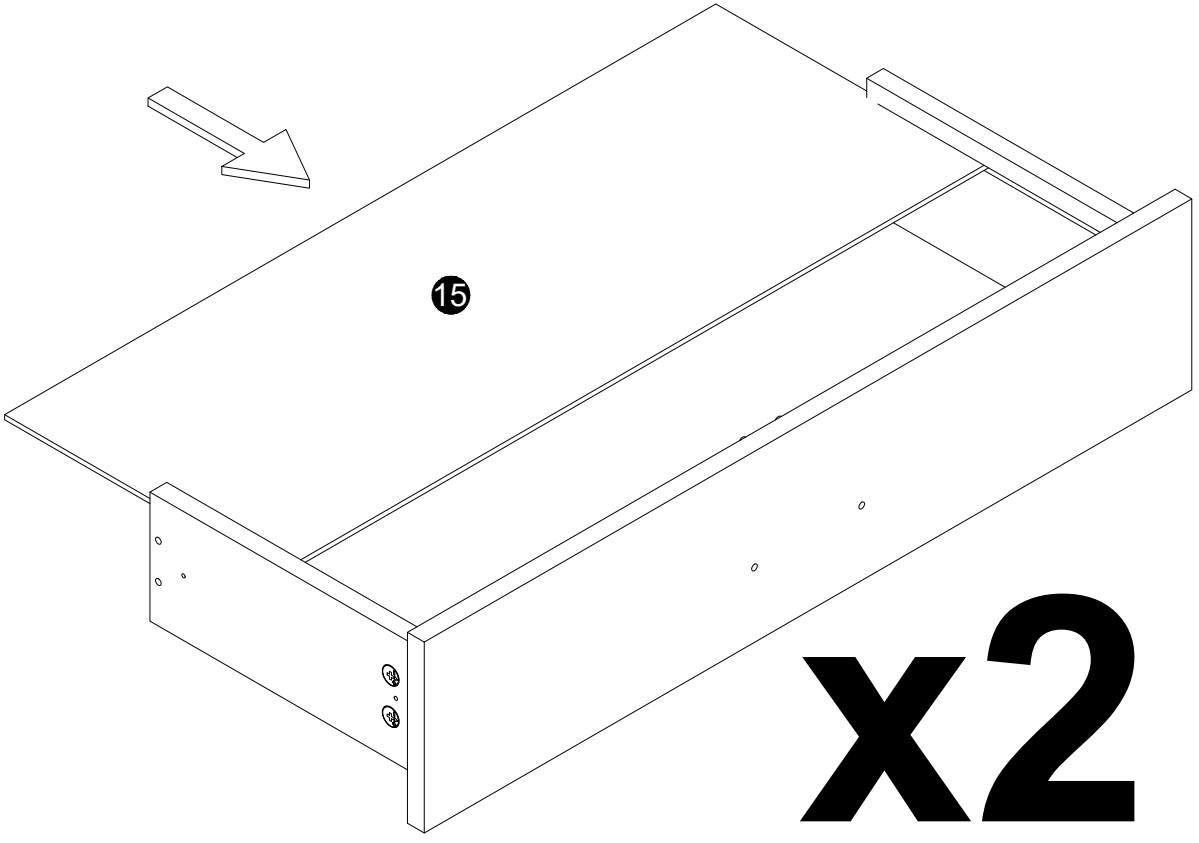

17

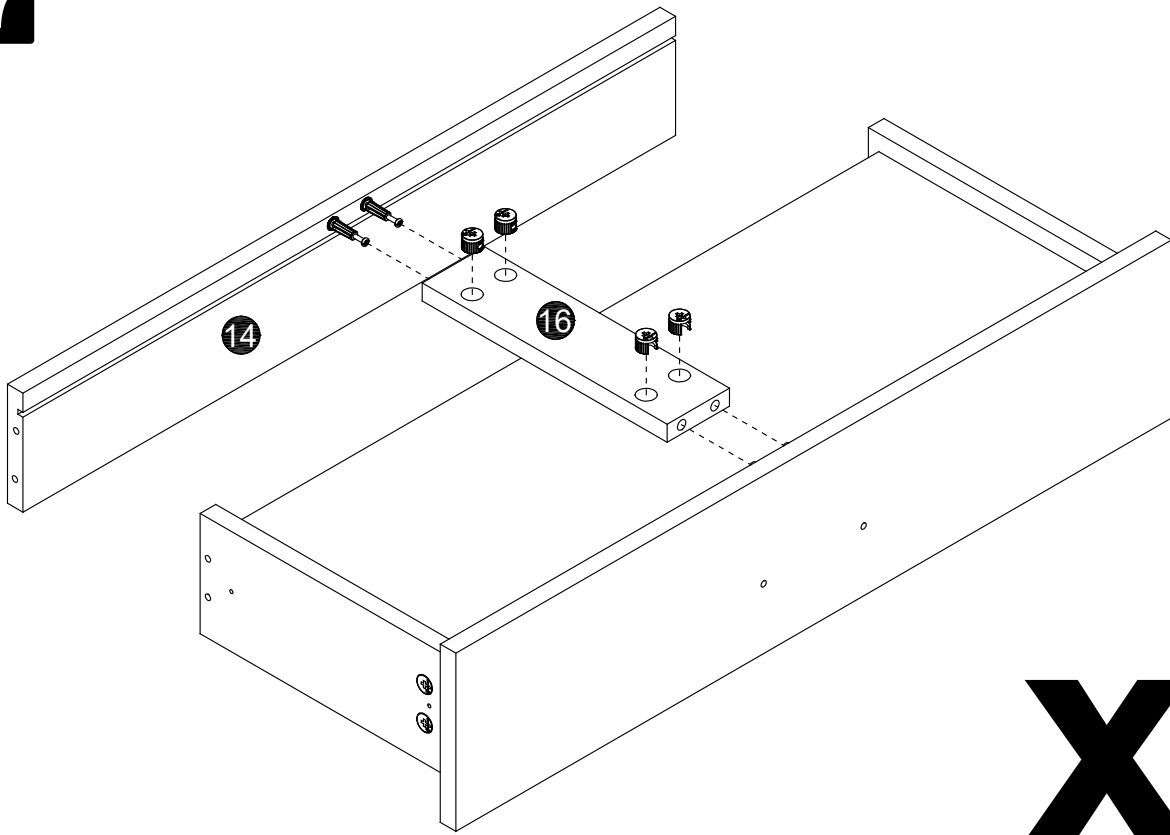

C
8 pcs

x2

18

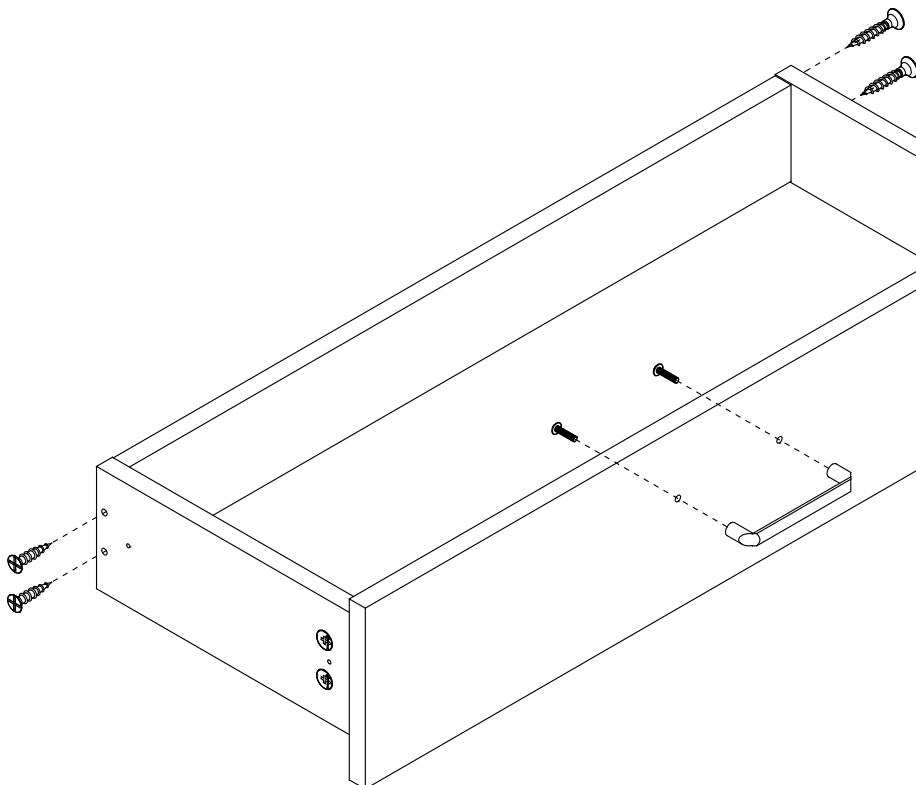



F	G	H
2 pcs	4 pcs	8 pcs

x2

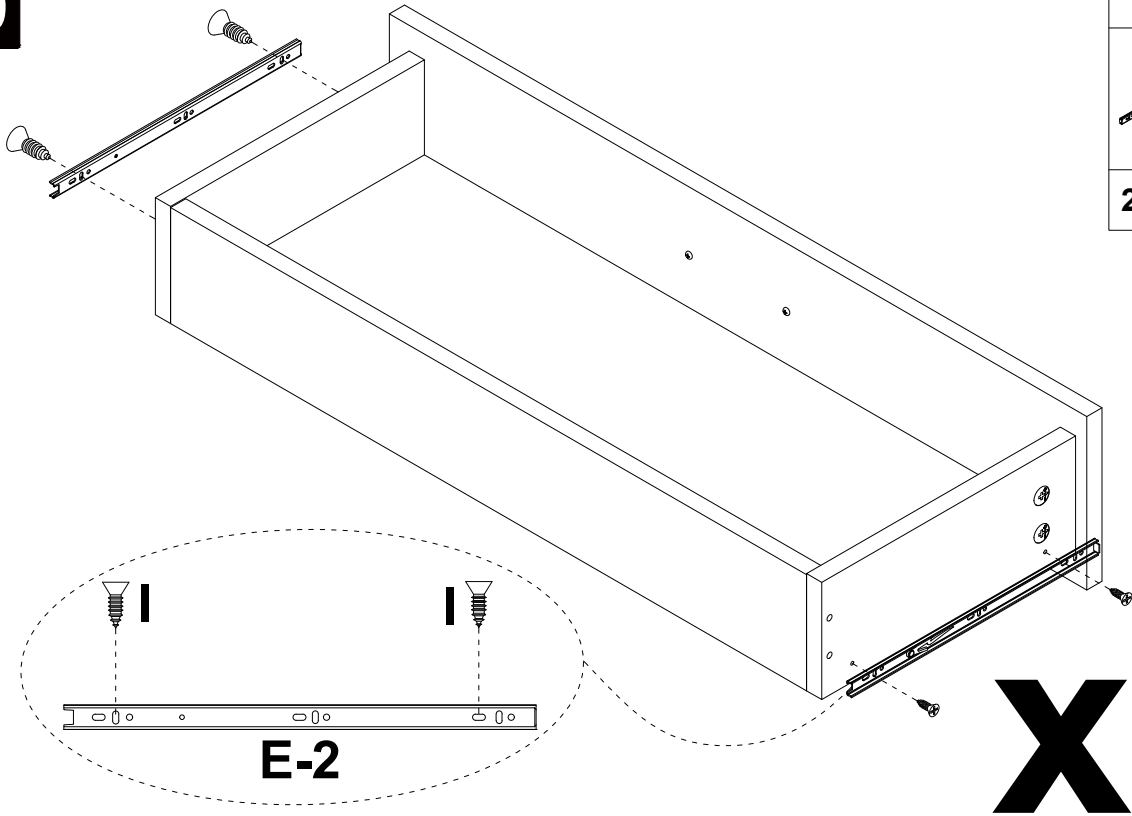

19

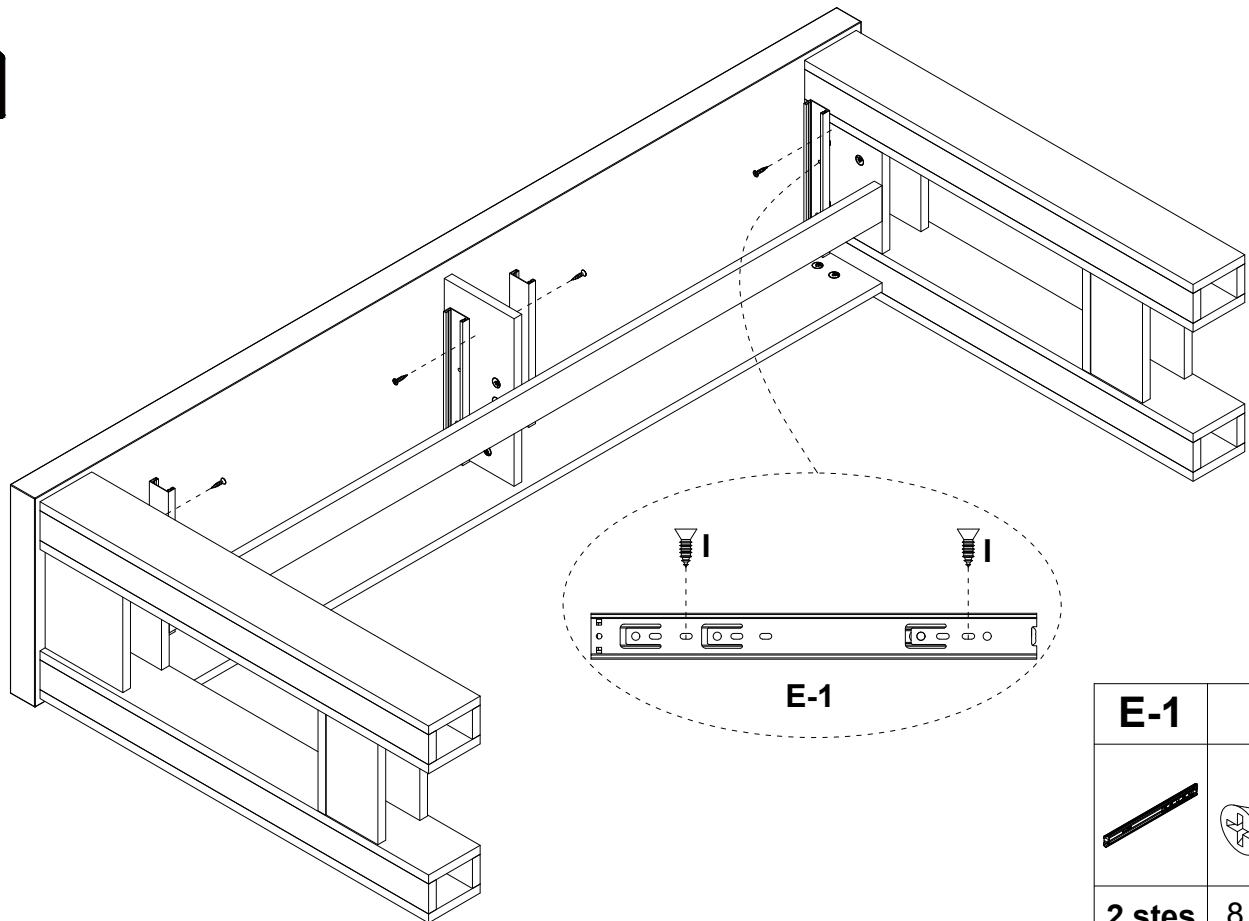

E-2	I
	
2 stes	8 pcs

20



E-1	I
	
2 stes	8 pcs

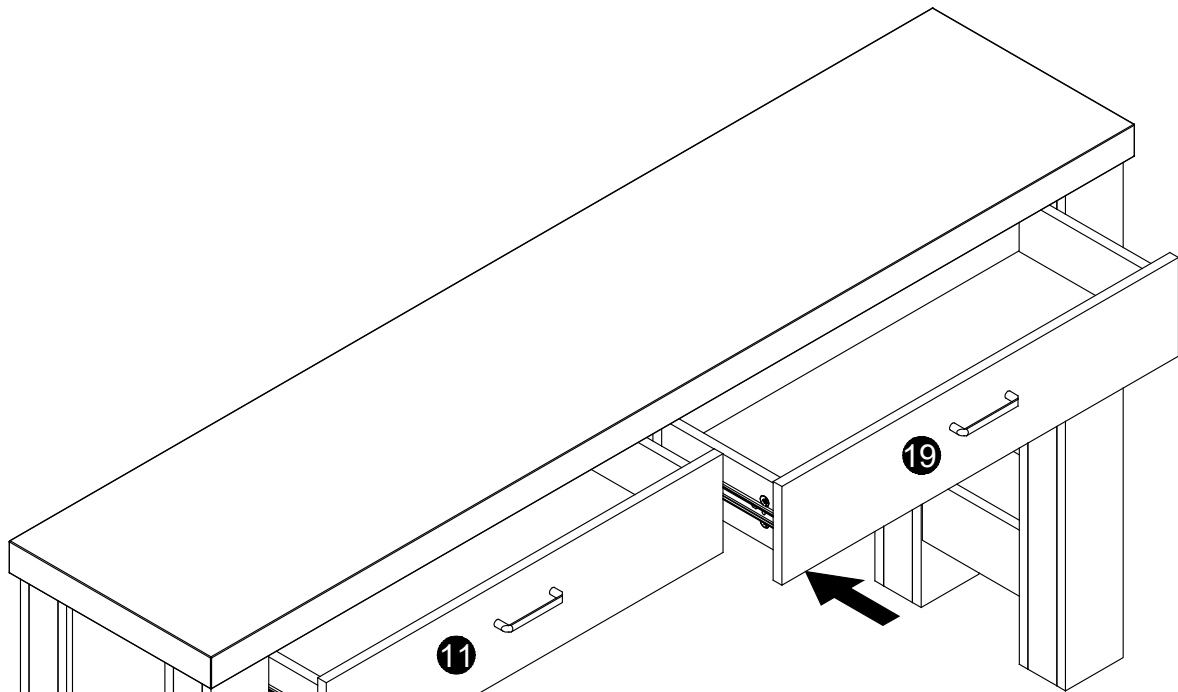

Step 1

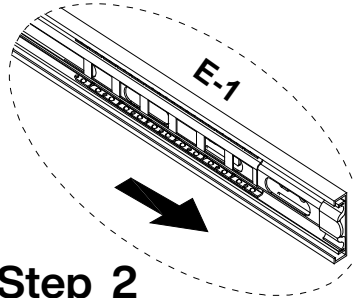

Step 2

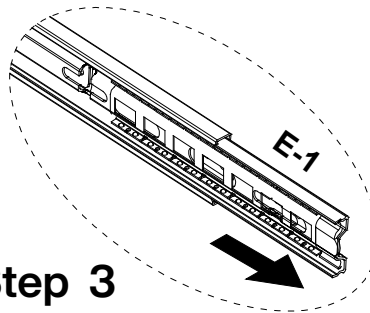

Step 3

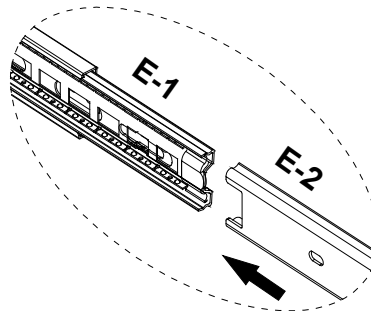

Before installation, slide the inner iron pieces of #E-1 to the outermost side. Then align it with #E-2 and gently push it inward to complete the slide installation.

22

L

2 pcs

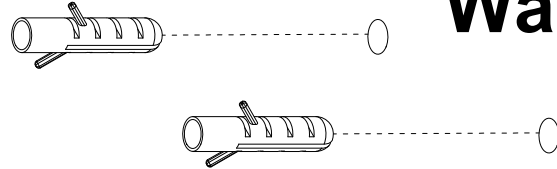
Step1

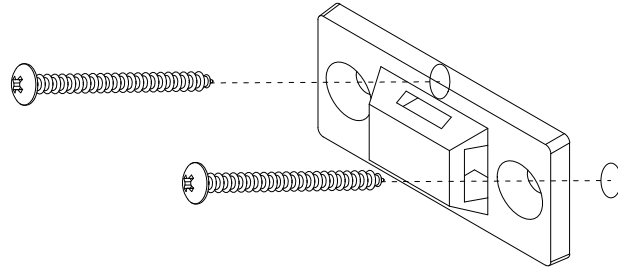

Step2



Step3

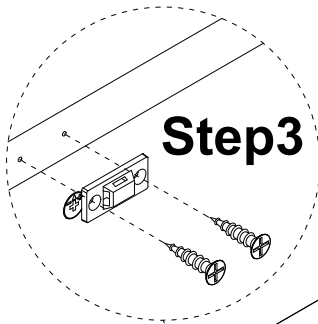

Step4

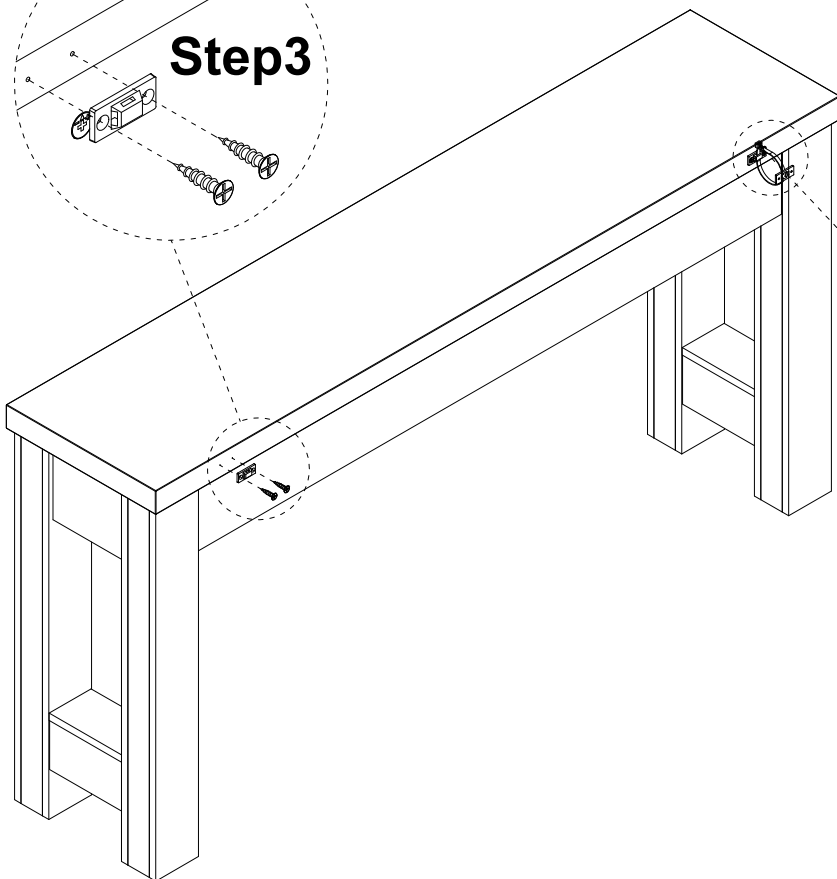

Thank you for your support!

