

ASSEMBLY INSTRUCTIONS

ITEM NO.:FB5023CHF

Option A: Left pullout sleeper

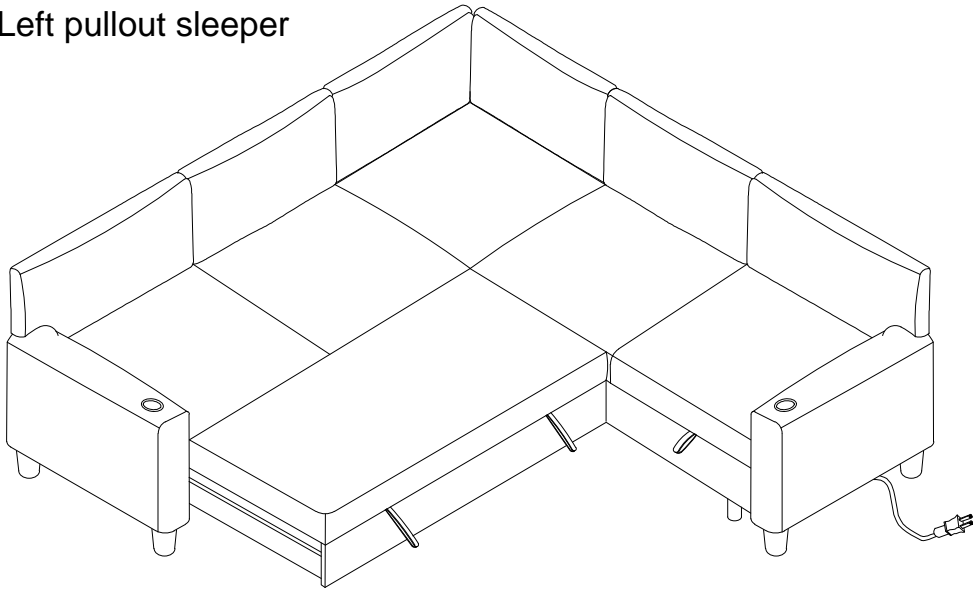



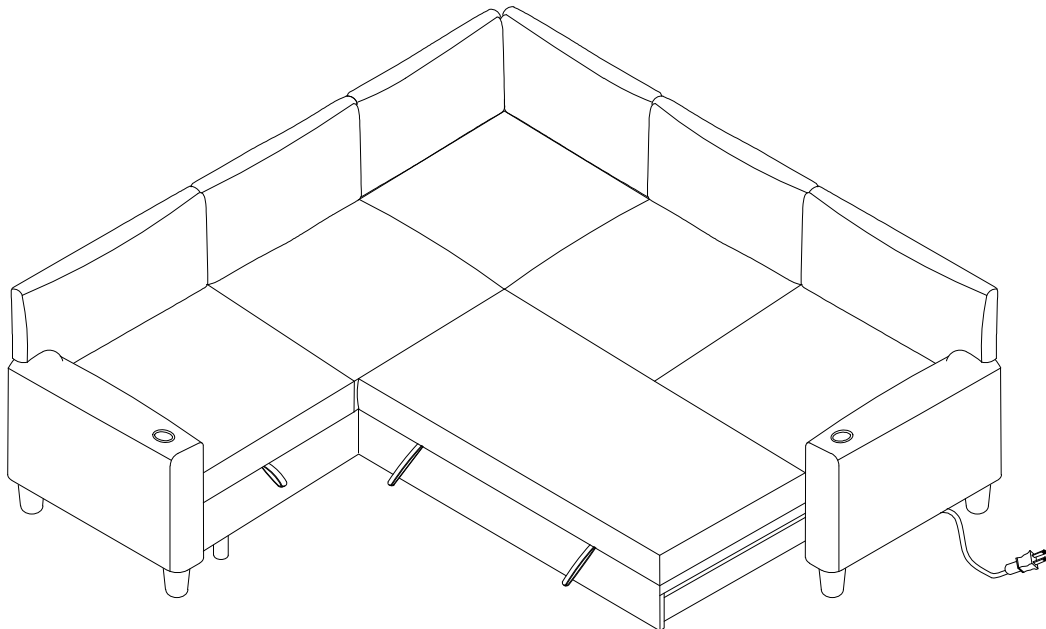







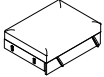

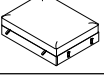
Option B: Right pullout sleeper



ASSEMBLY TIPS:

1. Remove hardware from box and sort by size.
2. Please check to see that all hardware and parts are present prior to start of assembly.
3. Please follow attached instructions in the same sequence as numbered to assure fast & easy assembly.

PARTS LIST

NO.	DIAGRAM	PART NAME	Q'Ty
1		Loveseat w/pullout sleeper	1PC
2		Corner	1PC
3		Loveseat w/storage	1PC
4		Left Arm	1PC
5		Right Arm	1PC
6		Loveseat Backrest	4PCS
7		Corner Backrest	2PCS
8		Loveseat Back Cushion (L)	1PC
9		Loveseat Back Cushion	2PCS
10		Loveseat Back Cushion (R)	1PC
11		Corner Back Cushion (L)	1PC
12		Corner Back Cushion (R)	1PC

HARDWARE LIST

NO.	DIAGRAM	PART NAME	Q'Ty
A		Allen Wrench M4	1PC
B		Bolts Ø1/4x20mm	8PCS
C		Wheels	4PCS
D		Round legs Ø80 x 97mmH	4PCS
E		Legs Ø45 x 97mmH	12PCS
F		Plastic Washer Ø45mm	16PCS
G		Flat Washer Ø16mm	8PCS

Exploded View

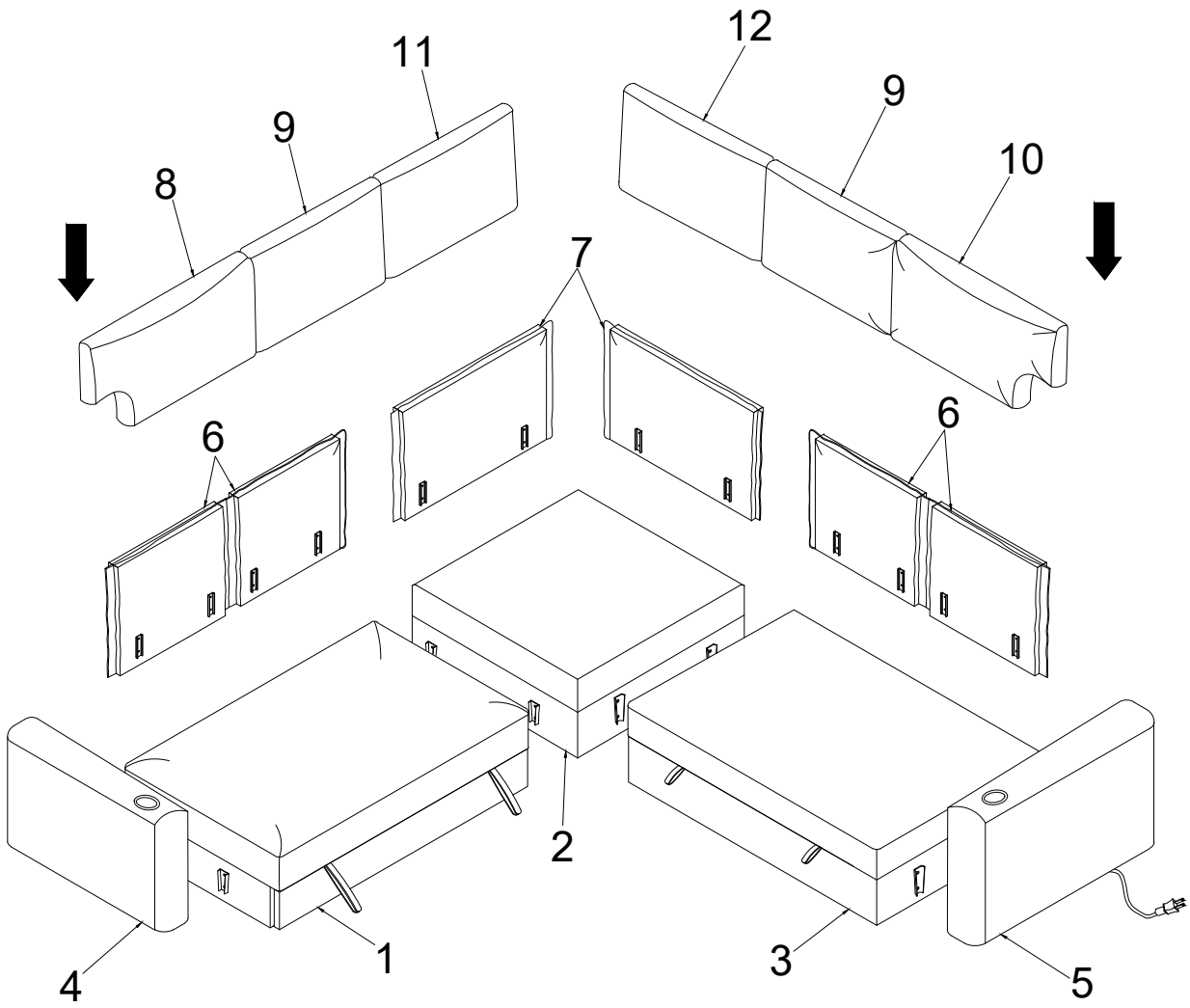

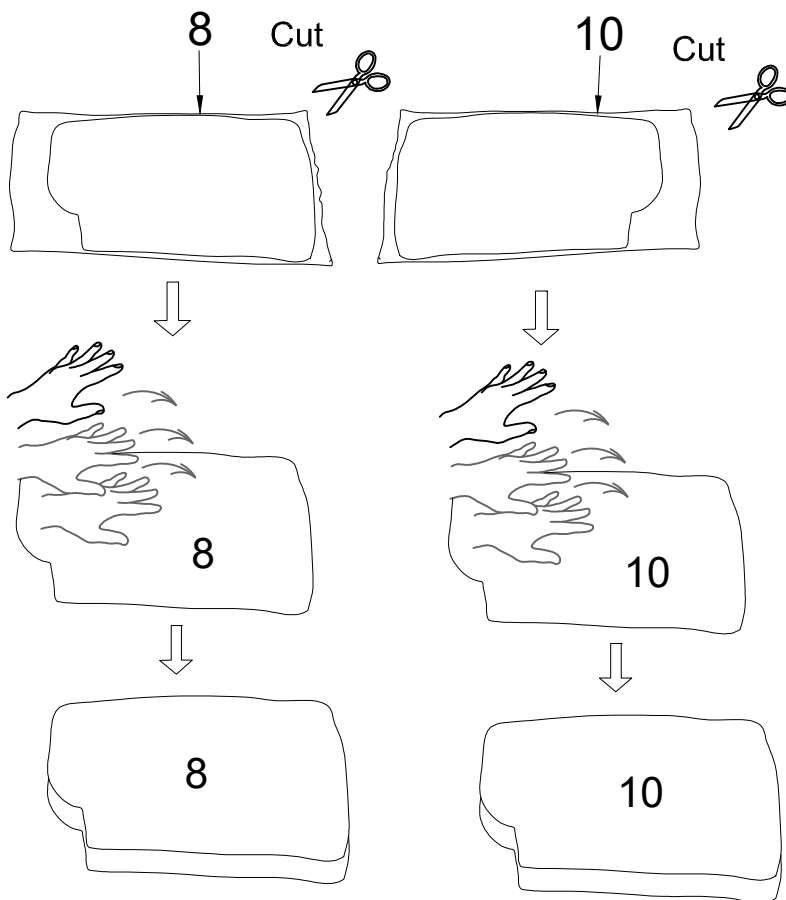
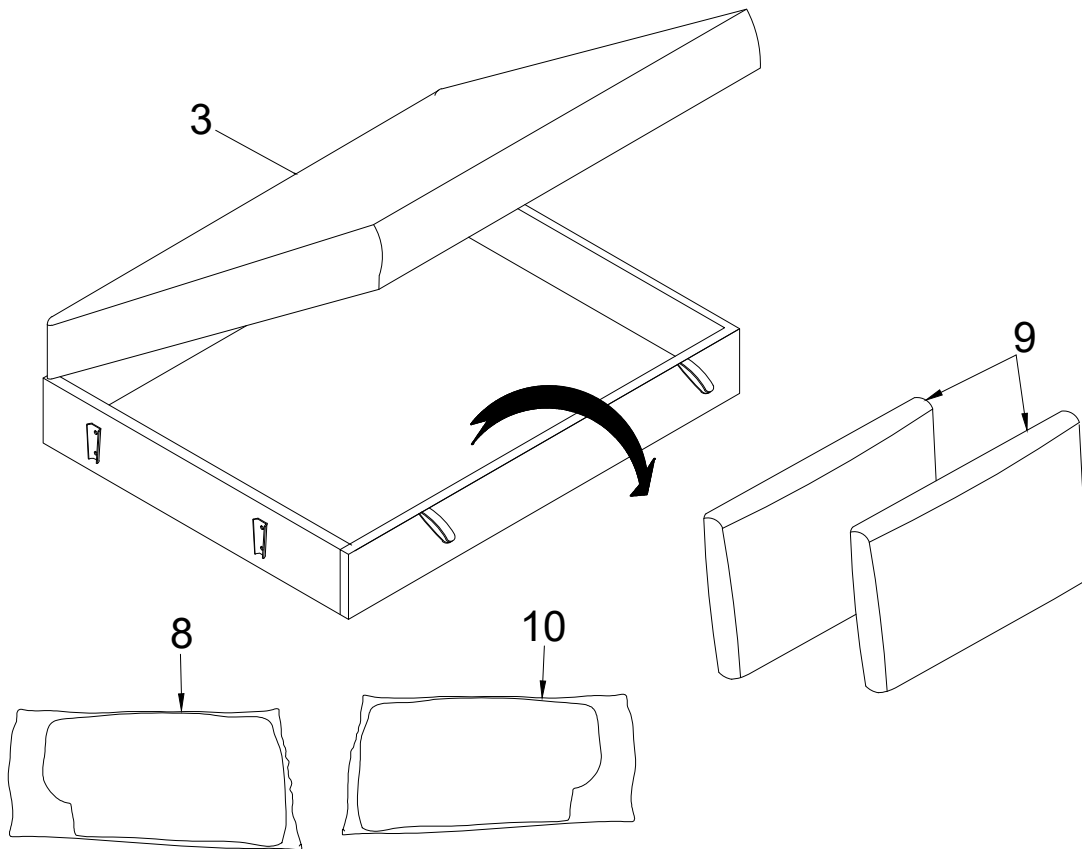

Carefully cut off the bagging, pat the cushion, the back cushion will resume to normal size.

STEP 1:

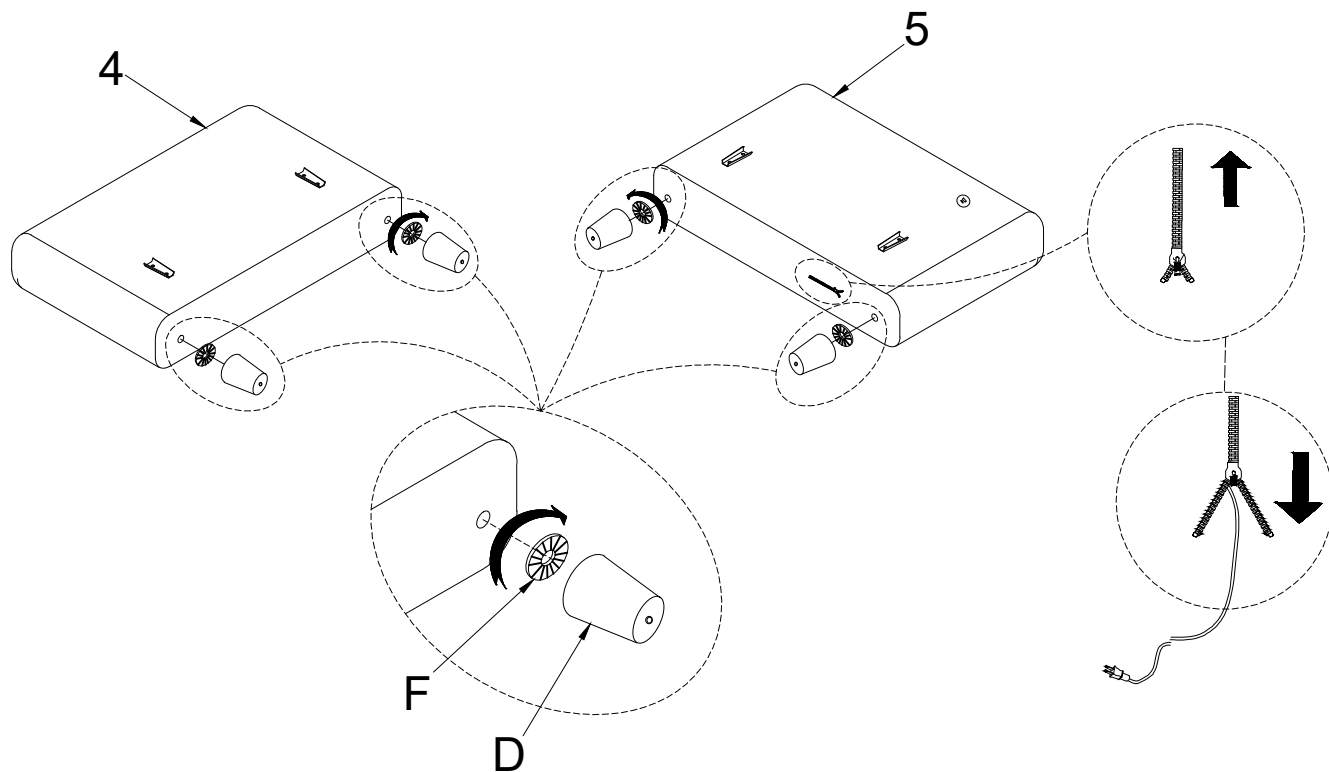

STEP 2:

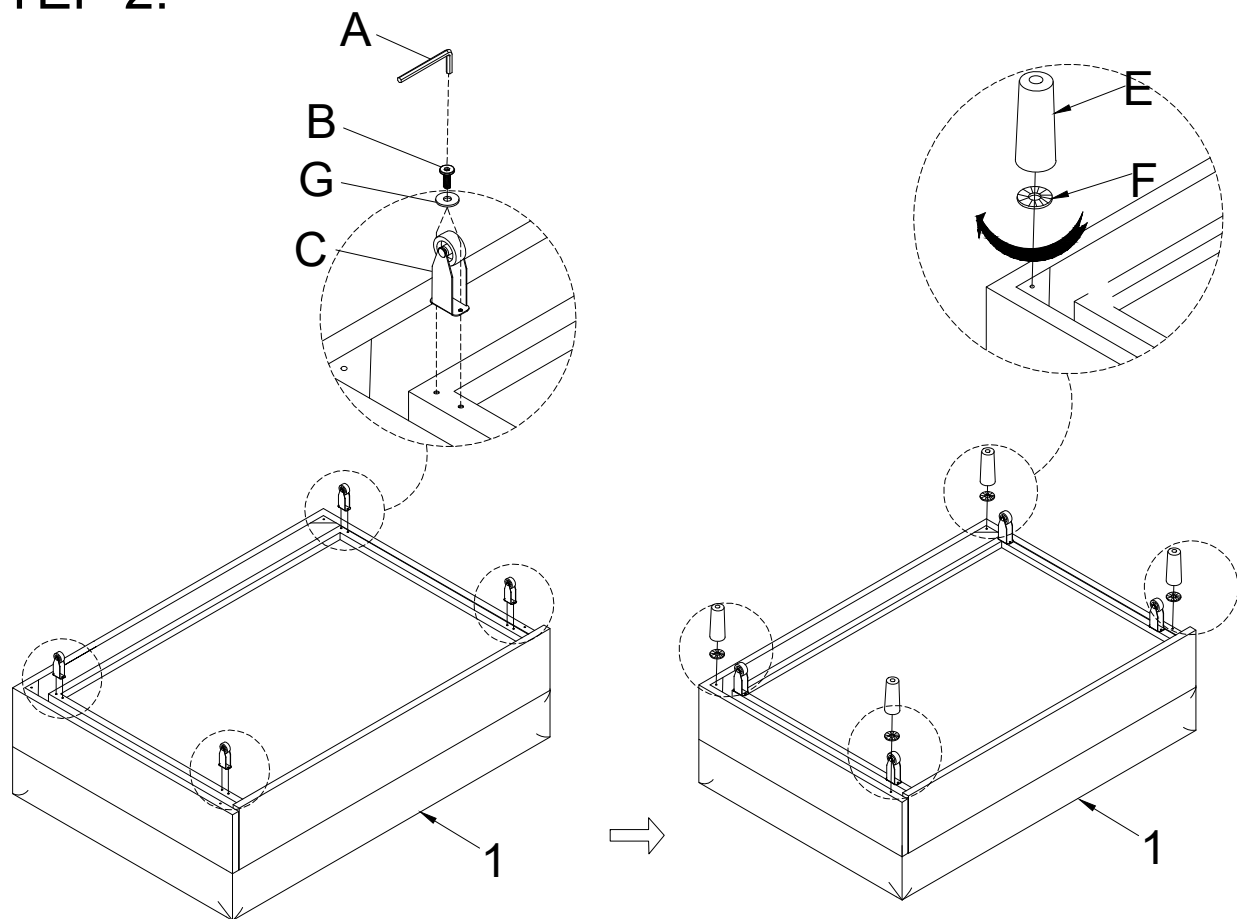

STEP 3:

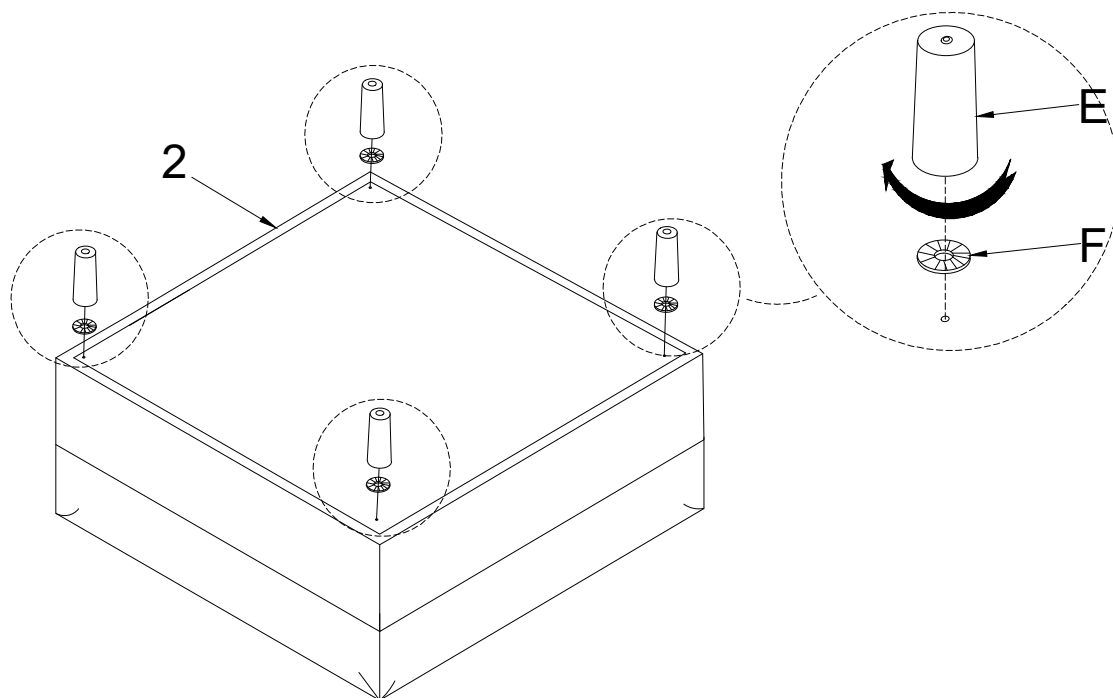

STEP 4:

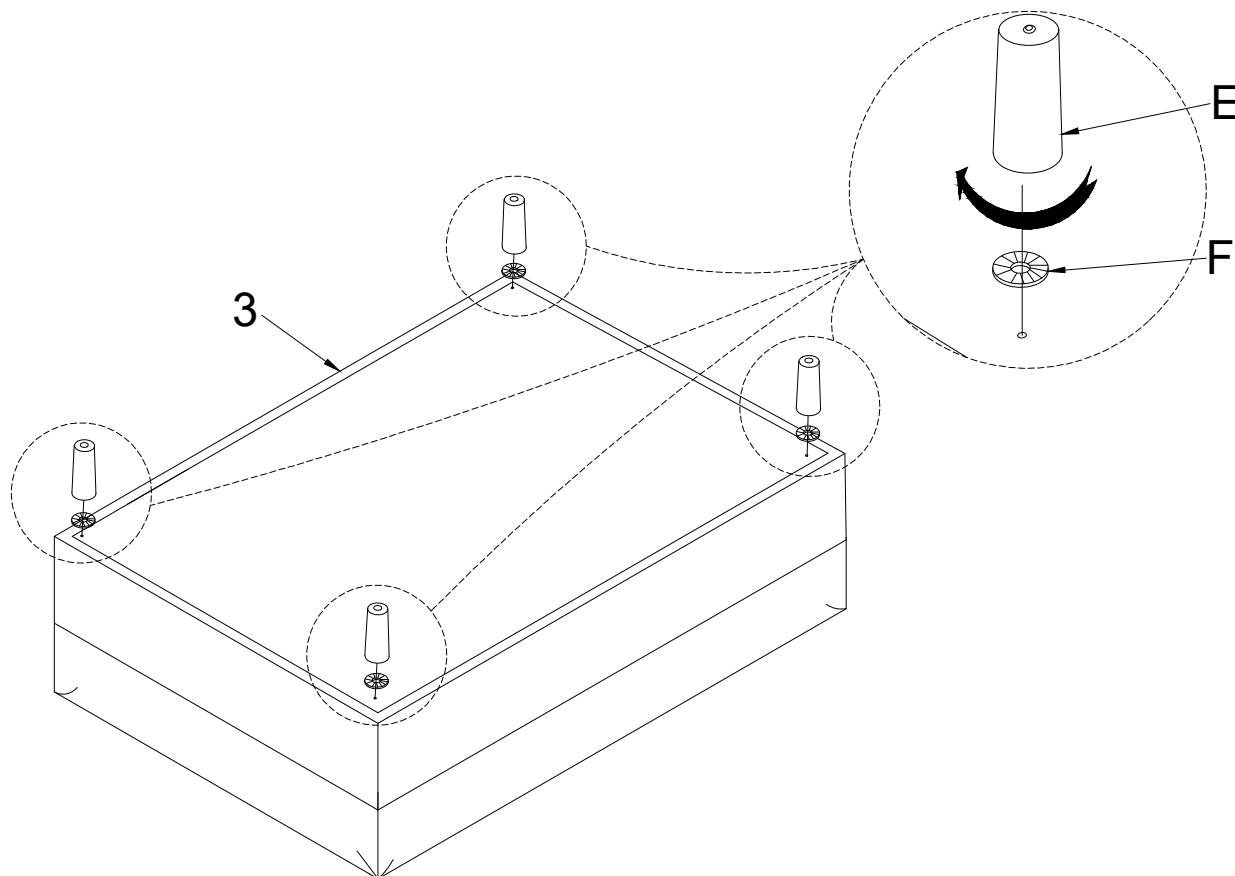

STEP 5:

Option A

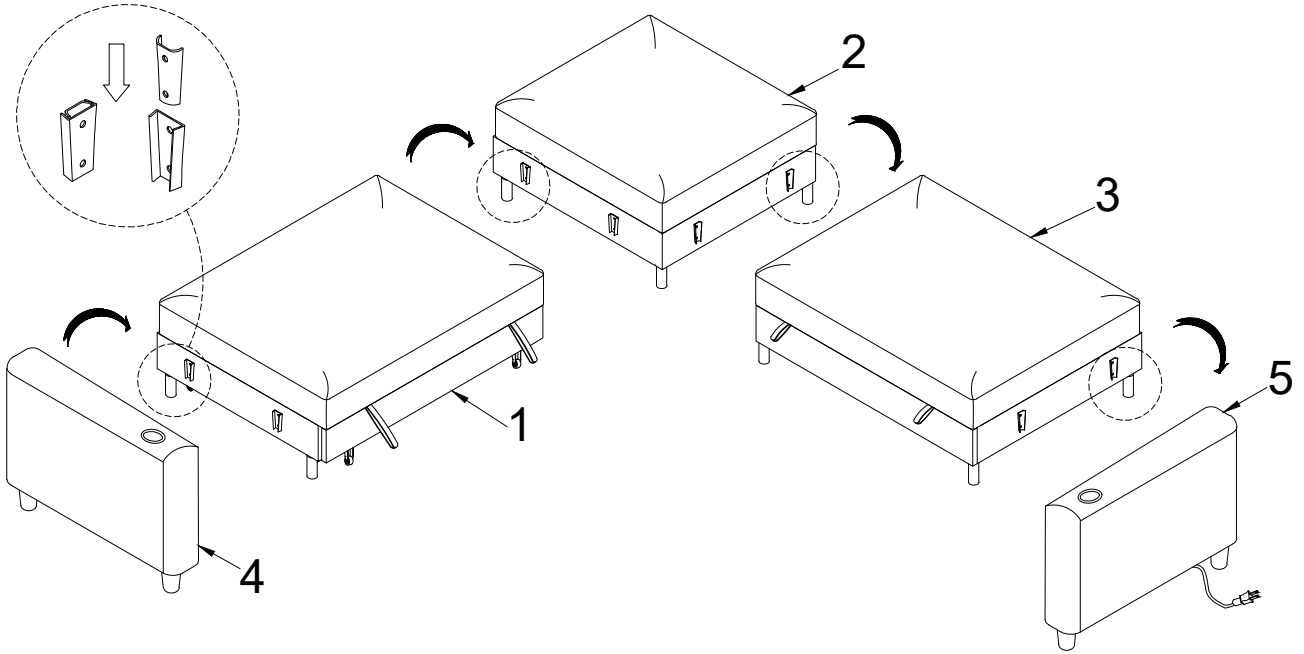

Option B

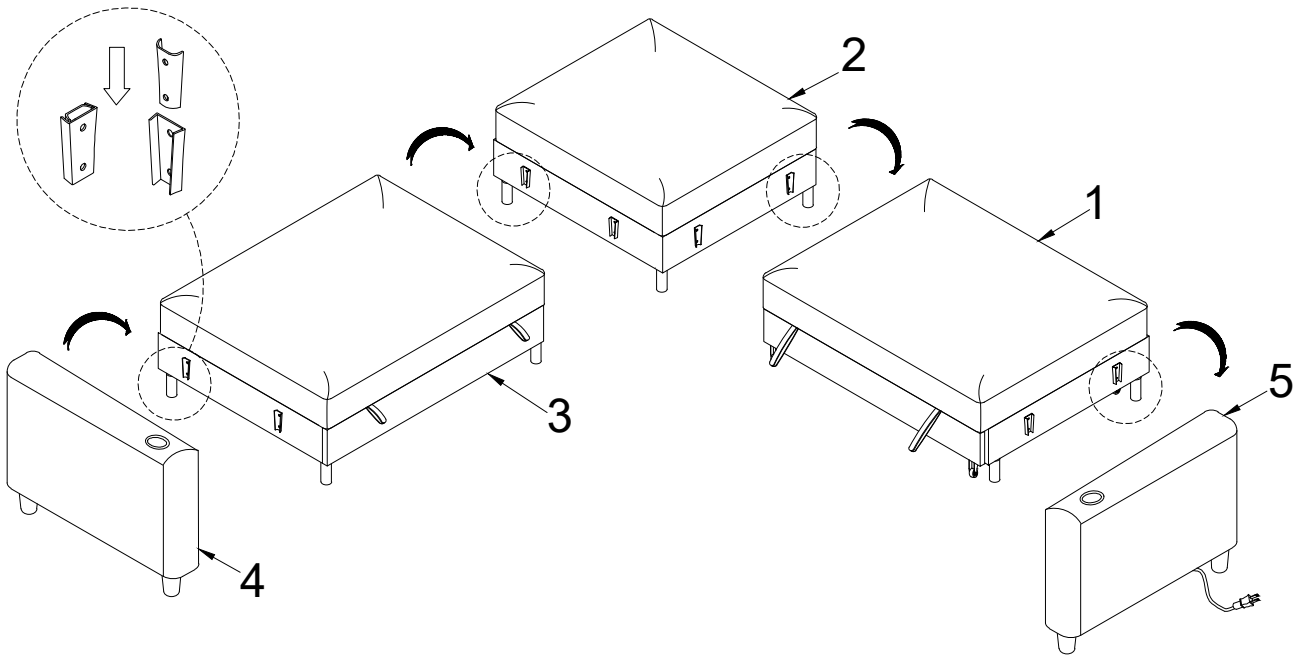

STEP 6

Option A

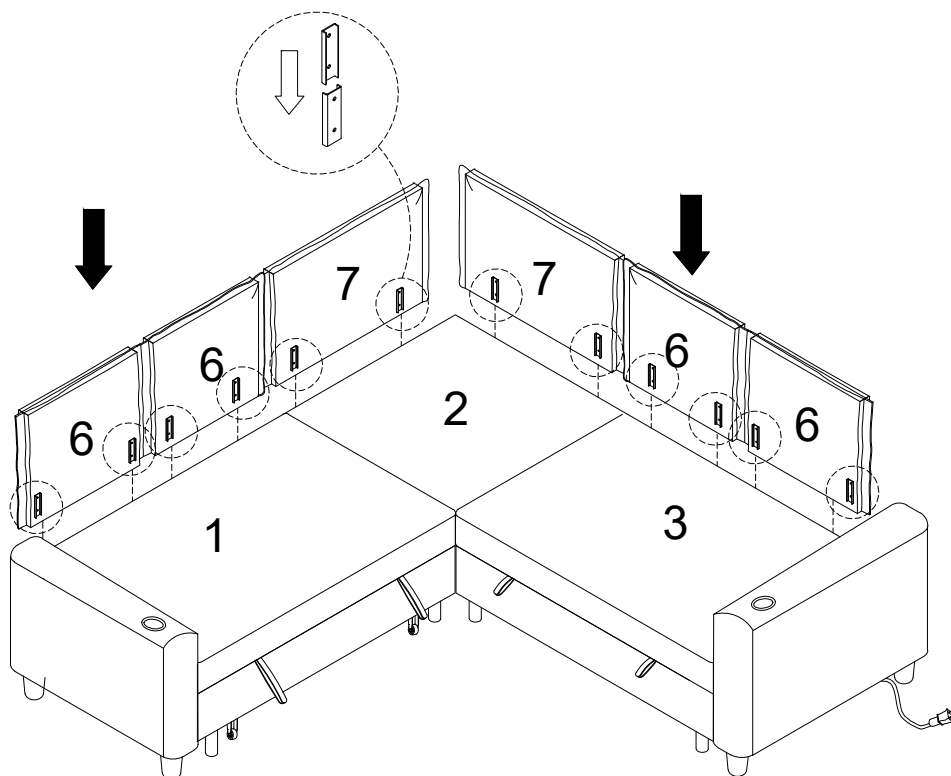

Option B

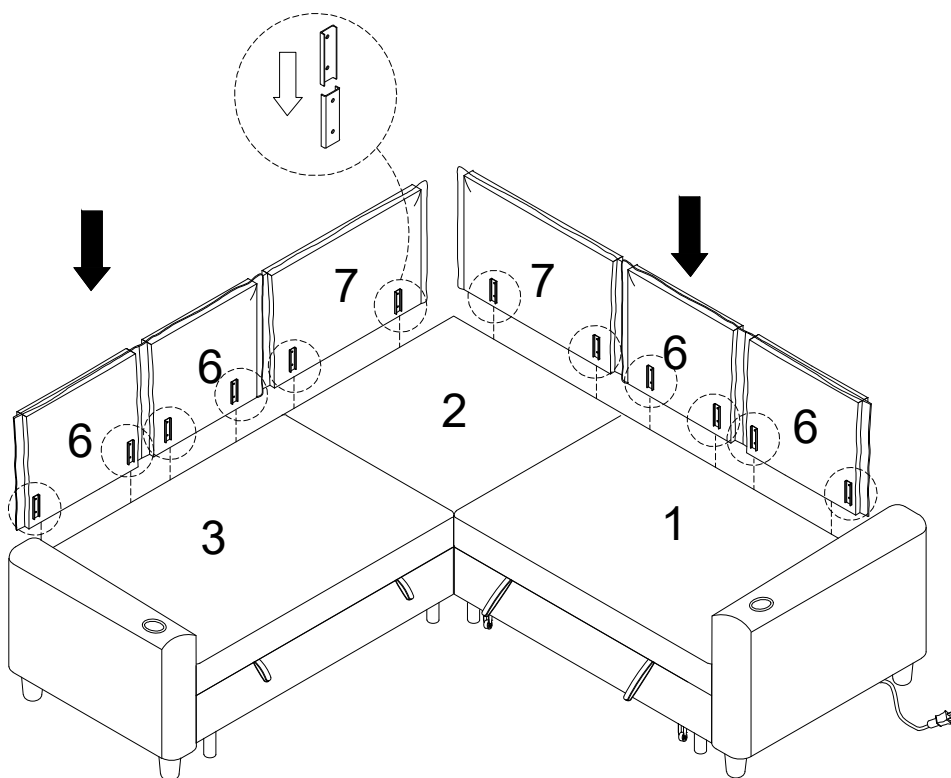

STEP 7

Option A

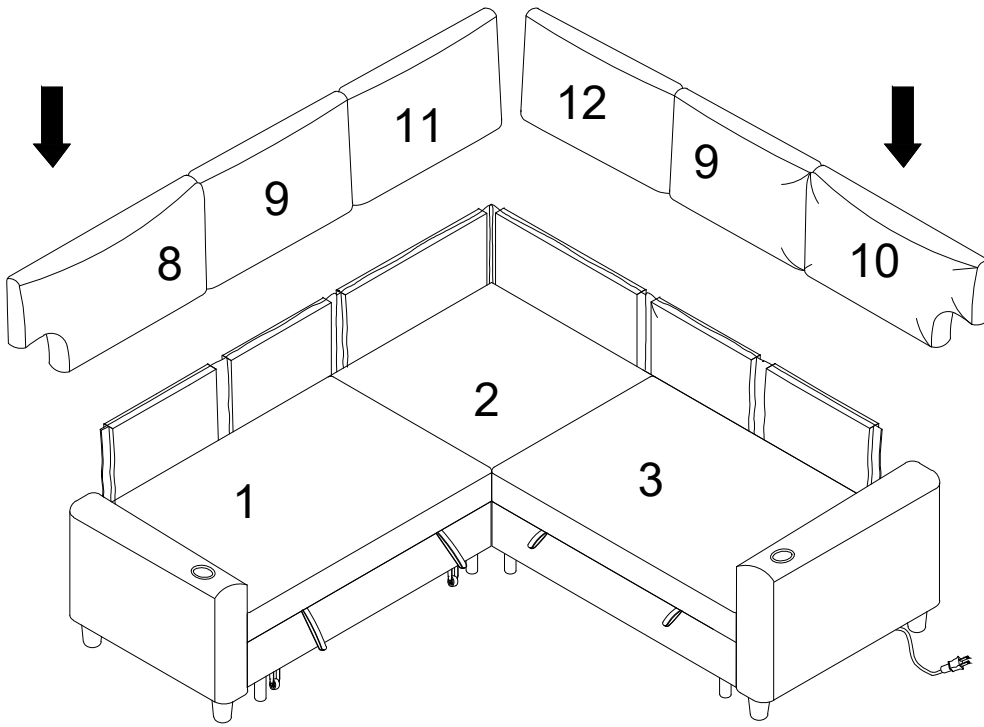

Option B

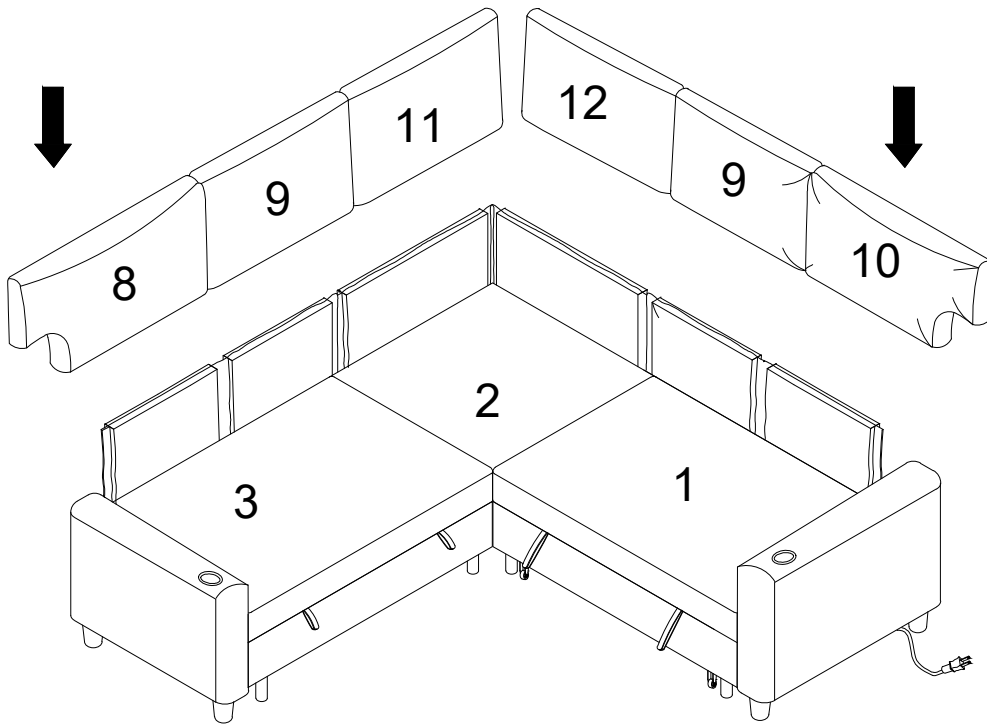

STEP 8

Option A

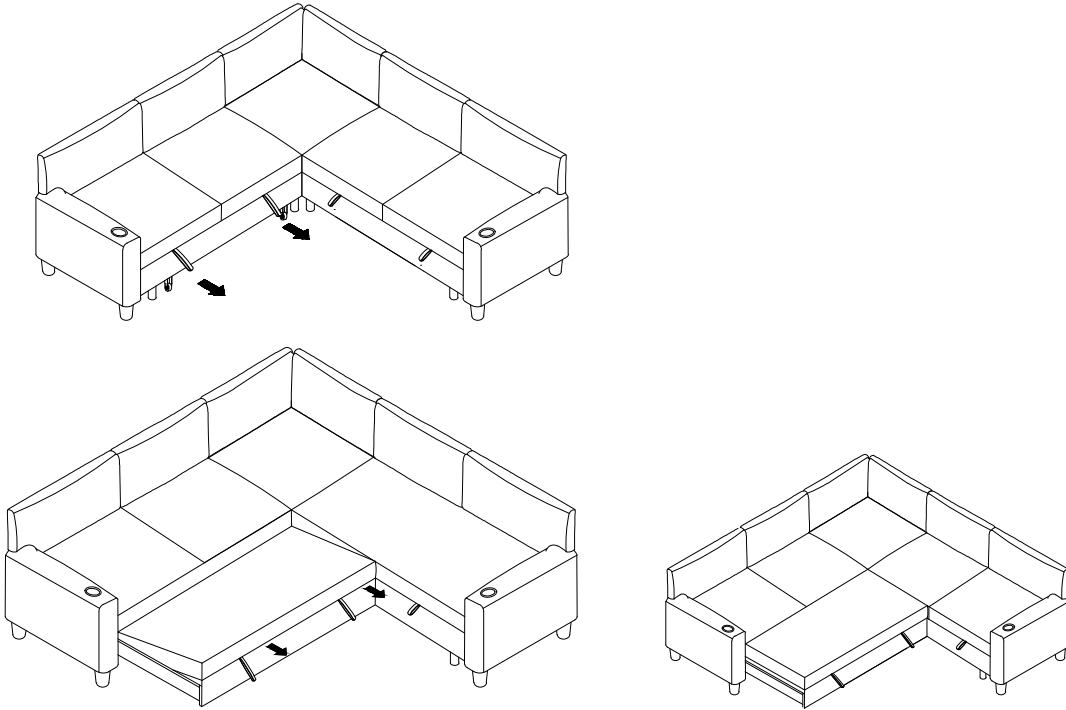

Option B

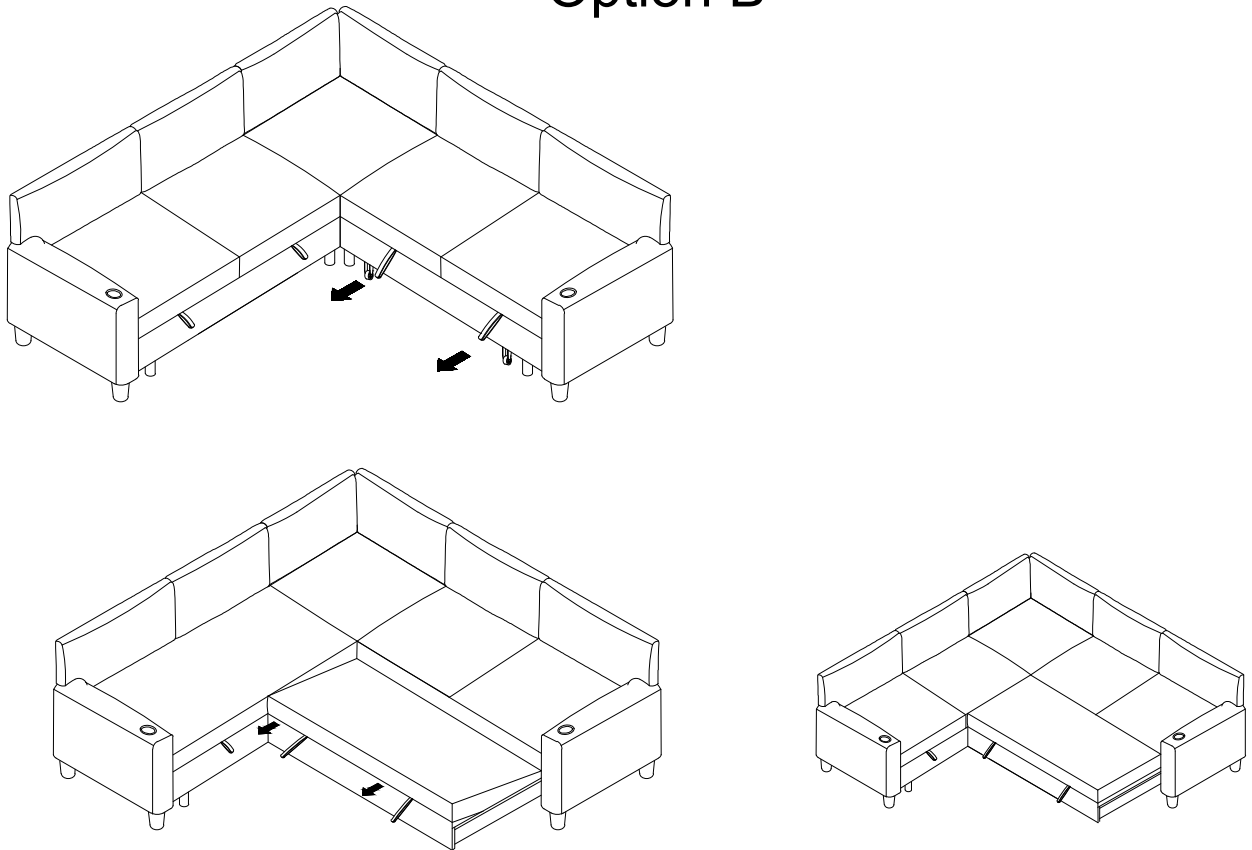

STEP 9

Option A

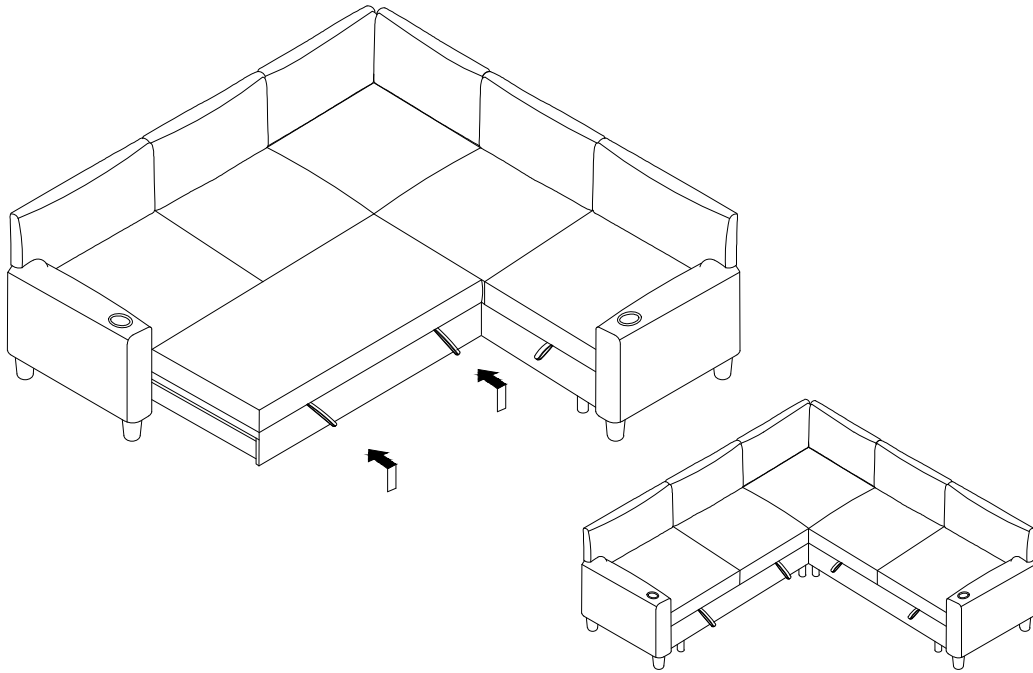

Option B

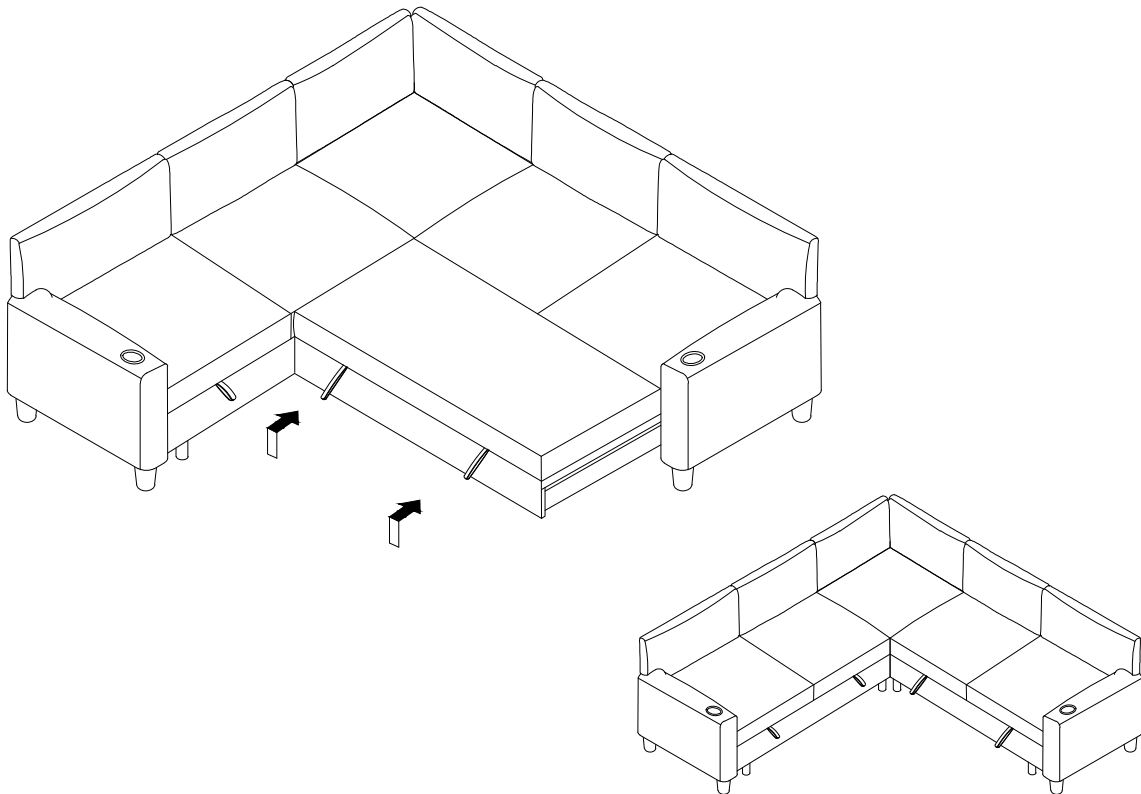

STEP 10

Option A

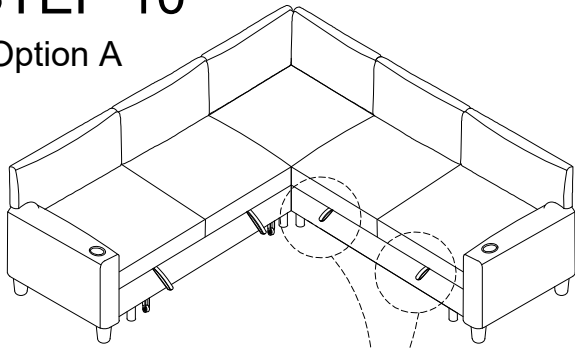

Option B

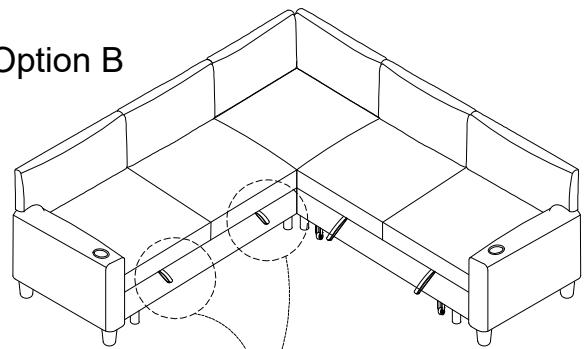

Note: when you want to store or take out something, you can do this step.

STEP 11

