

# INSTRUCTION MANUAL

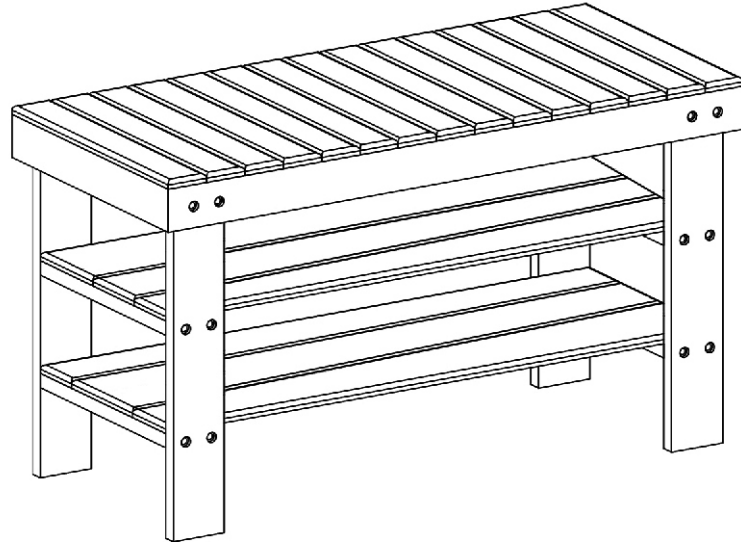

## ! NOTICE

**Do not overtighten screws. (Insert all screws before tighten screws.)**

- Please do not exceed the weight limitations of this item.
- Do not stand on or use any part of this item as a step ladder.
- Firmly secure all bolts, screws and nuts before use.
- Reconfirm that all bolts, screws, and nuts are secure every 90 days.
- Do not use or store this item in the proximity of open flame or flammable/combustible chemicals
- Be aware that some parts are heavy and have sharp edges.
- Avoid using strong power tool for avoiding to crack the PE board when assembling.



TABLE  
180LBS  
CAPACITY



2 PERSON  
ASSEMBLY



UP TO 20 MIN.  
ASSEMBLY

## HARDWARE

## PARTS

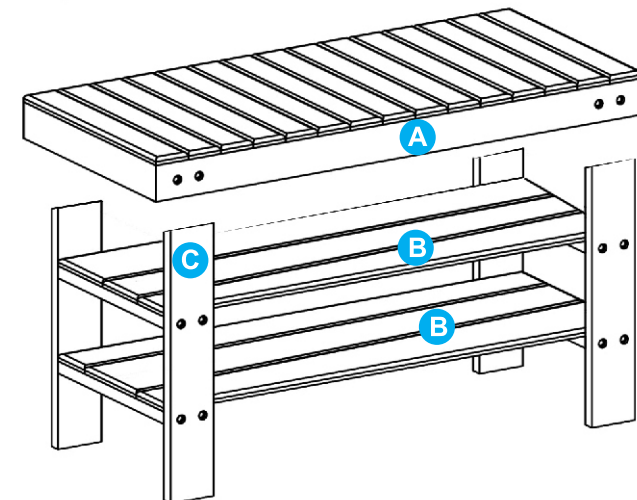
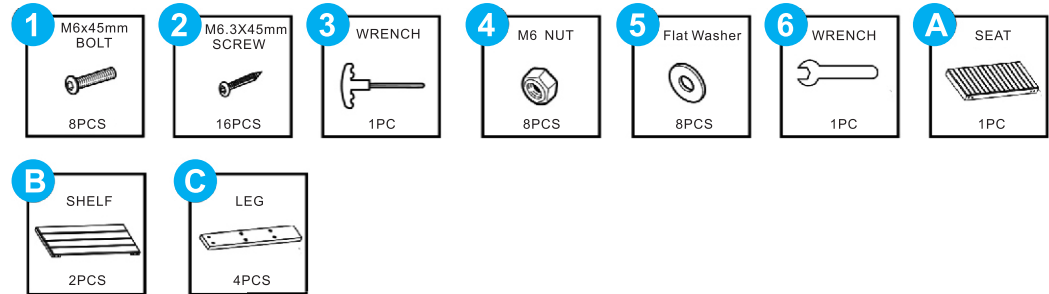

## PRODUCT ASSEMBLY

- 1** Attach Legs C to shelves B. Secured with Screws (2) and Wrench (3). Lightly tighten the screws.

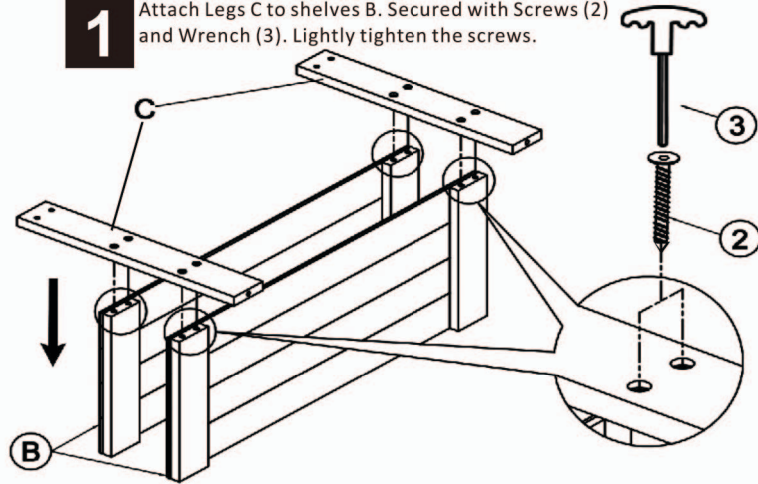

## PRODUCT ASSEMBLY

- 2** Attach Legs C to Shelves B. Secured with Screws (2) and Wrench (3). Lightly tighten the screws.

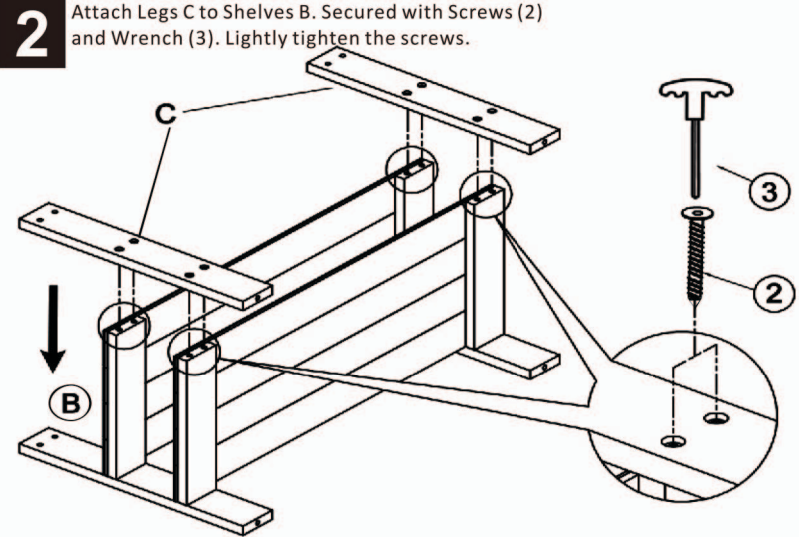

- 3** Attach Legs C to Seat A. Secured with Screws (1) Flat Washer (5), Nut (4) and Wrench (6). Tighten all the screws.

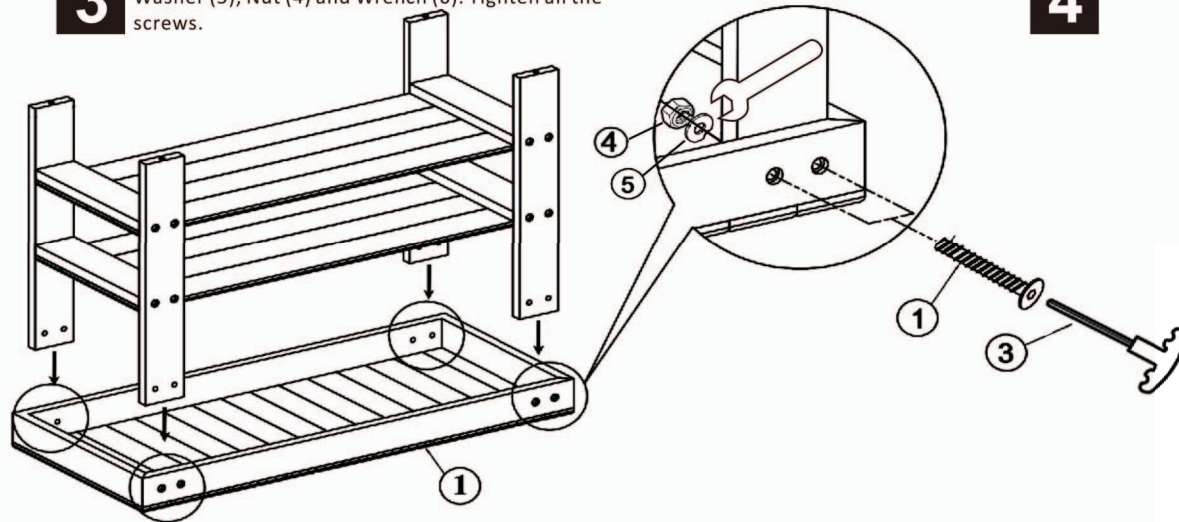

- 4** Assembly completed.

