











ASSEMBLY INSTRUCTIONS

KEEP THIS DOCUMENT FOR REFERENCE IN CASE PARTS ARE NEEDED
DO NOT TIGHTEN SCREWS UNTIL COMPLETELY ASSEMBLED !

No.	DESCRIPTION	Q'TY FOR 1PC
A	TABLE TOP	1pc
B	BOX PANEL	1pc
C	TABLE LEG (1,2,3,4)	4pcs
D	LONG STRETCHER	1pc
E	SHORT STRETCHER	1pc
F	SHELF	3pcs

No.	DESCRIPTION	Q'TY FOR 1PC
1	BOLT  $\Phi 5/16'' \times 60\text{MM}$	8pcs
2	BOLT  $\Phi 1/4'' \times 38\text{MM}$	6pcs
3	SPRING WASHER  $\Phi 5/16''$	8pcs
4	METAL WASHER  $\Phi 5/16''$	8pcs
5	SPRING WASHER  $\Phi 1/4''$	6pcs
6	METAL WASHER  $\Phi 1/4''$	6pcs
7	SCREW  M4*12mm	14pcs
8	SCREW  M4*45mm	2pcs
9	SHELF SUPPORT 	12pcs
10	ALLEN KEY  M4	1pc

STEP 1

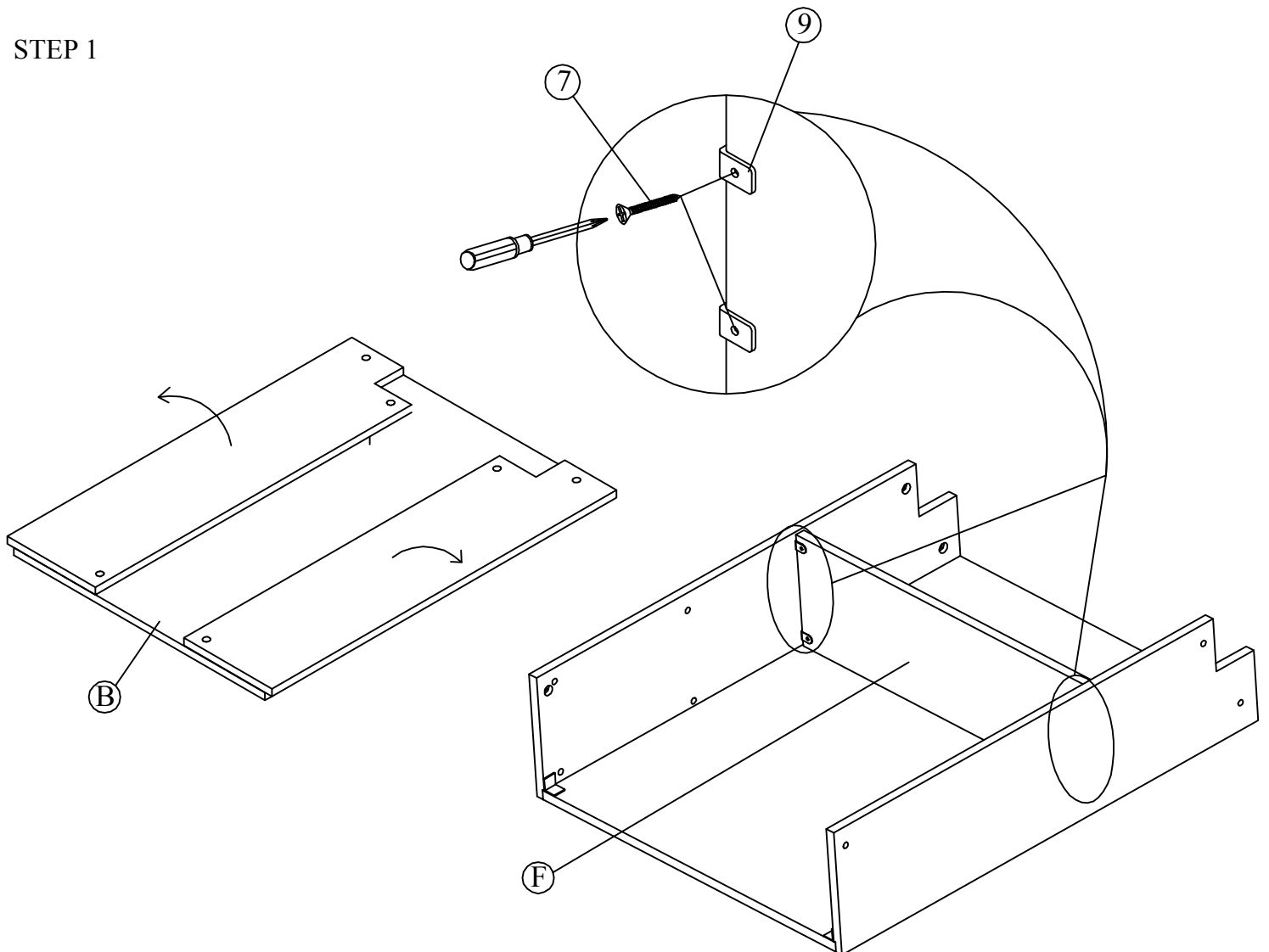

ASSEMBLY INSTRUCTIONS

KEEP THIS DOCUMENT FOR REFERENCE IN CASE PARTS ARE NEEDED
DO NOT TIGHTEN SCREWS UNTIL COMPLETELY ASSEMBLED !

STEP 2

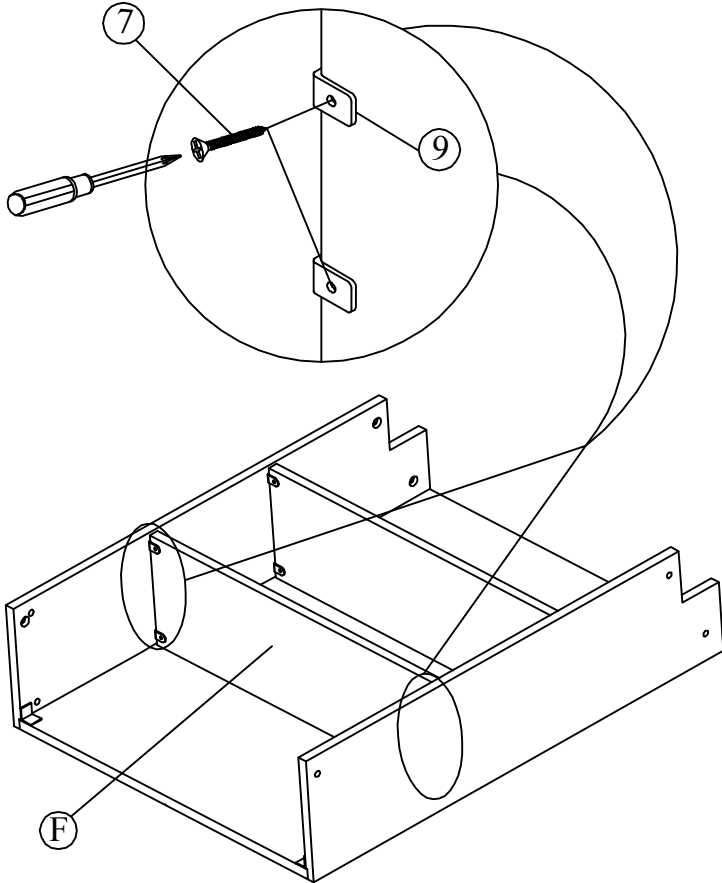

STEP 3

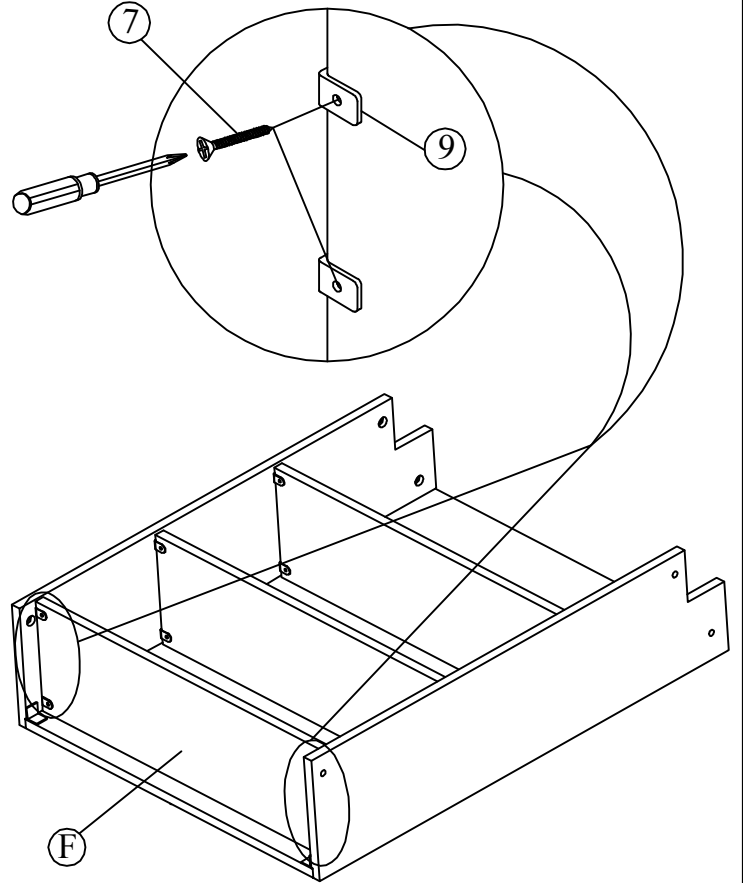

STEP 4

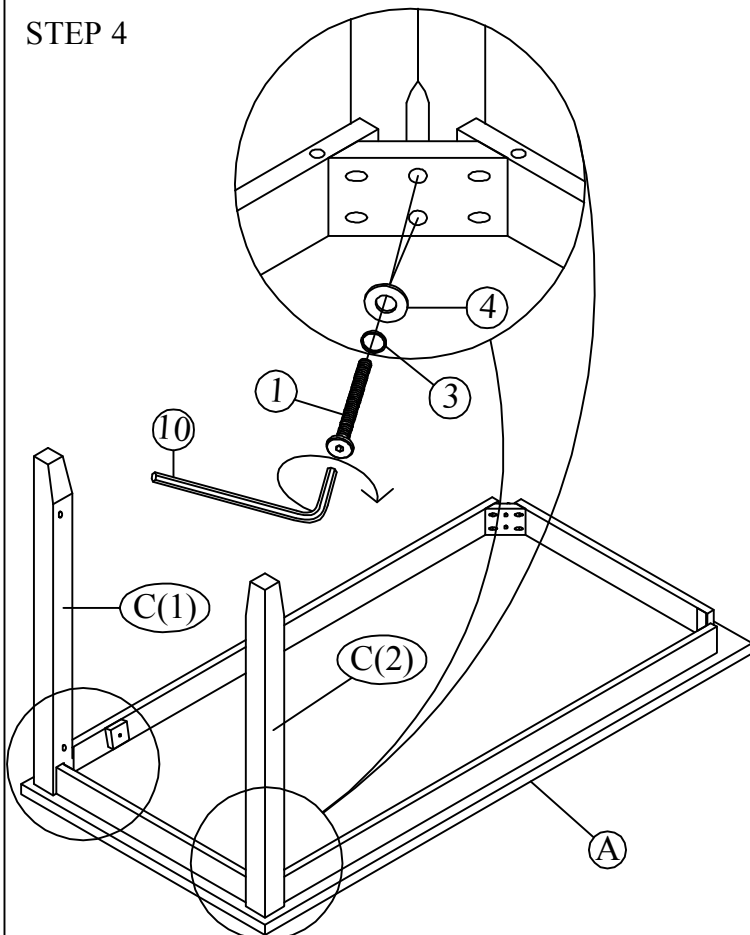

STEP 5

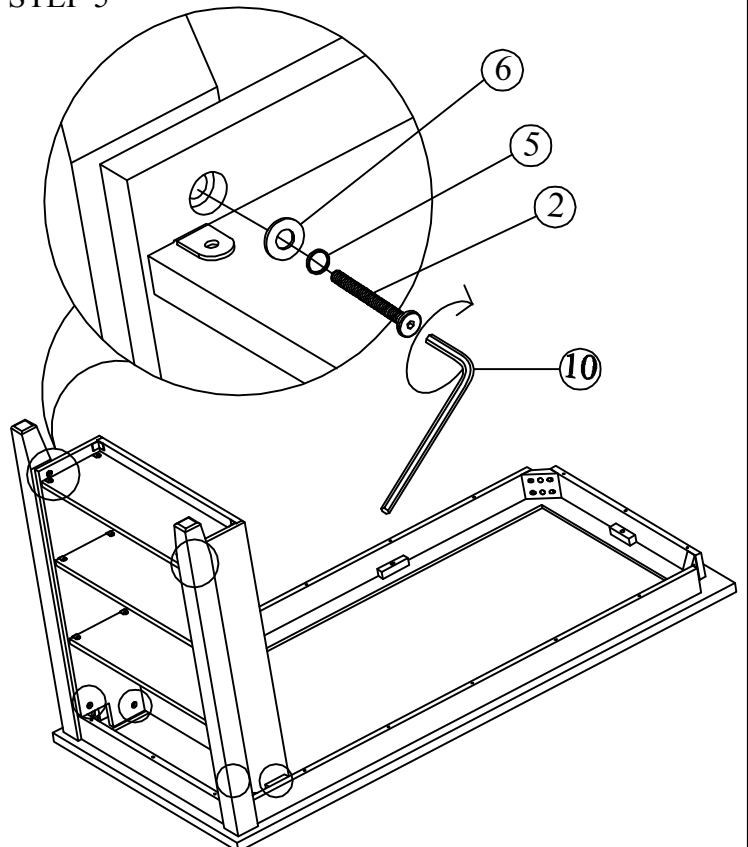

ASSEMBLY INSTRUCTIONS

KEEP THIS DOCUMENT FOR REFERENCE IN CASE PARTS ARE NEEDED
DO NOT TIGHTEN SCREWS UNTIL COMPLETELY ASSEMBLED !

STEP 6

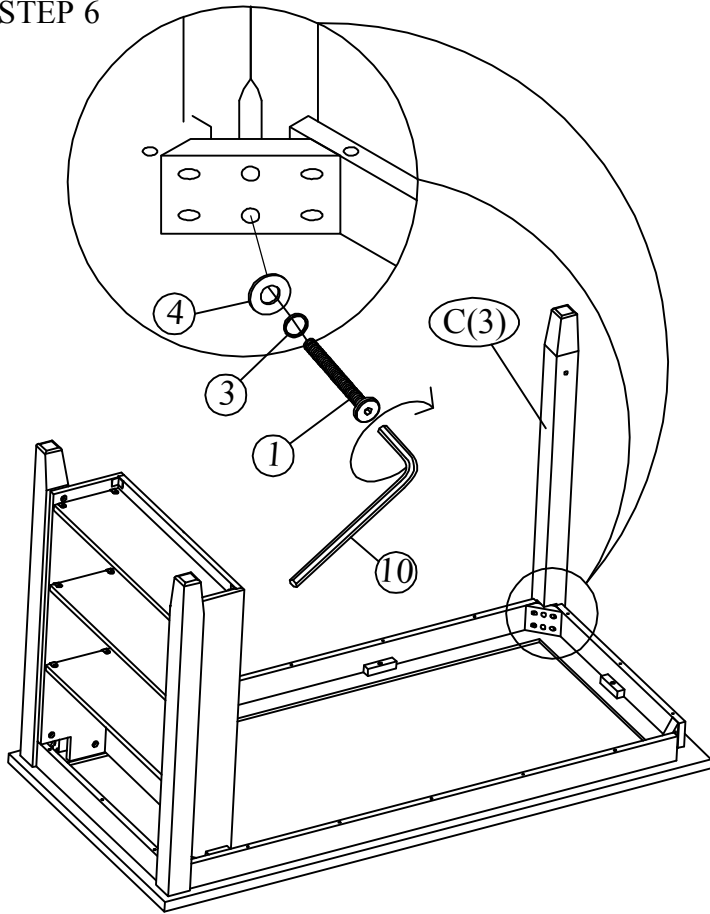

STEP 7

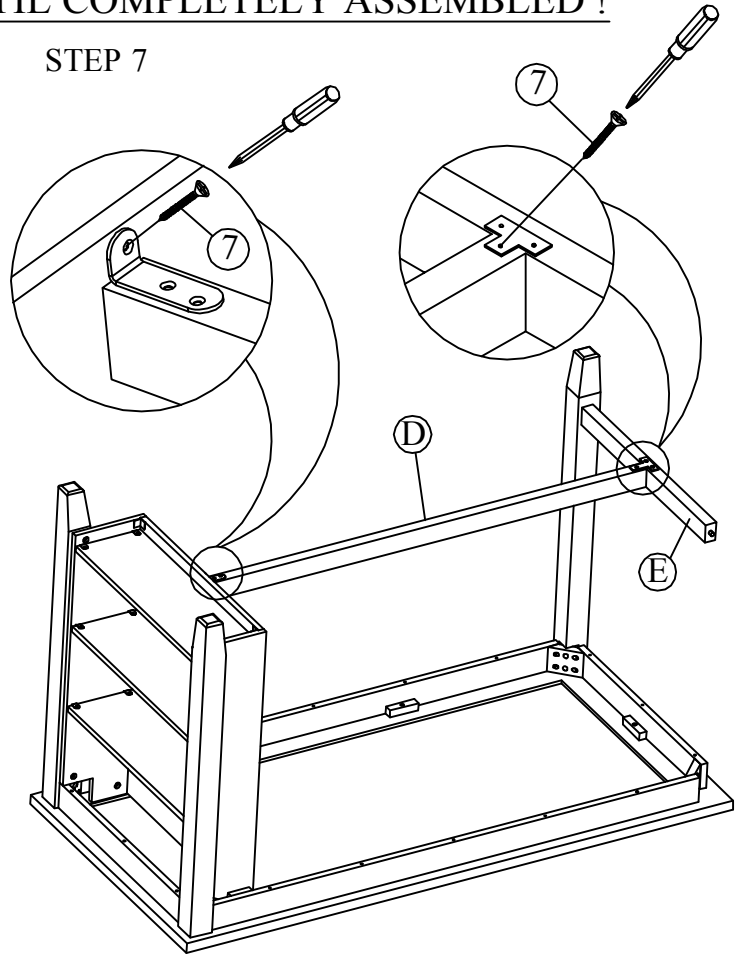

STEP 8

