



Vestil Manufacturing Co.
 2999 North Wayne Street, P.O. Box 507, Angola, IN 46703
 Telephone: (260) 665-7586 -or- Toll Free (800) 348-0868
 Fax: (260) 665-1339
 Website: www.vestilmfg.com e-mail: info@vestil.com

MTC-Series Manual Trash Compactors

Instruction Manual



Receiving Instructions

After delivery, remove the packaging from the product. Inspect the product closely to determine whether it sustained damage during transport. If damage is discovered, record a complete description of it on the bill of lading. If the product is undamaged, discard the packaging.

NOTE: The end-user is solely responsible for confirming that product design, use, and maintenance comply with laws, regulations, codes, and mandatory standards applied where the product is used.

Technical Service & Replacement Parts

For answers to questions not addressed in these instructions and to order replacement parts, labels, and accessories, call our Technical Service and Parts Department at (260) 665-7586. The Department can also be contacted online at <https://www.vestil.com/page-parts-request.php>.

Electronic Copies of Instruction Manuals

Additional copies of this instruction manual may be downloaded from <https://www.vestil.com/page-manuals.php>.

Table of Contents		Page
Signal Words.....		2
Specifications.....		2
Exploded View and Bill of Materials.....		3
Assembling the Compactor.....		4, 5
Assembling Optional Roll-Out Base MTC-RB.....		5
Exploded View: Roll-Out Base Option (MTC-RB).....		6
MTC-RB Assembly Diagrams.....		6
Using the Compactor.....		7
Labeling Diagram.....		7
Moving the Compactor.....		8
Record of Original Condition.....		8
Maintenance & Inspections.....		8
Limited Warranty.....		9

SIGNAL WORDS

This manual uses SIGNAL WORDS to indicate the likelihood that a particular action will cause personal injuries or property damage. Signal words also specify the level of seriousness of injury if the product is misused in the ways described. The following signal words are used in this manual.



Identifies a hazardous situation which, if not avoided, WILL result in DEATH or SERIOUS INJURY. Use of this signal word is limited to the most extreme situations.



Identifies a hazardous situation which, if not avoided, COULD result in DEATH or SERIOUS INJURY.



Indicates a hazardous situation which, if not avoided, COULD result in MINOR or MODERATE injury.



Identifies practices likely to result in product/property damage, such as operation that might damage the boom.

SPECIFICATIONS

The jack produces 7,000 pounds of compacting force, which allows the operator to reduce the size of waste material and optimize space in waste storage drums. Both MTC models include wheels on one side of the base plate to allow an operator to easily reposition the unit. Each compactor has a pin to secure the handle while it is not in use. Dimensions, net weight, and maximum compacting force figures appear in the following diagrams and tables.

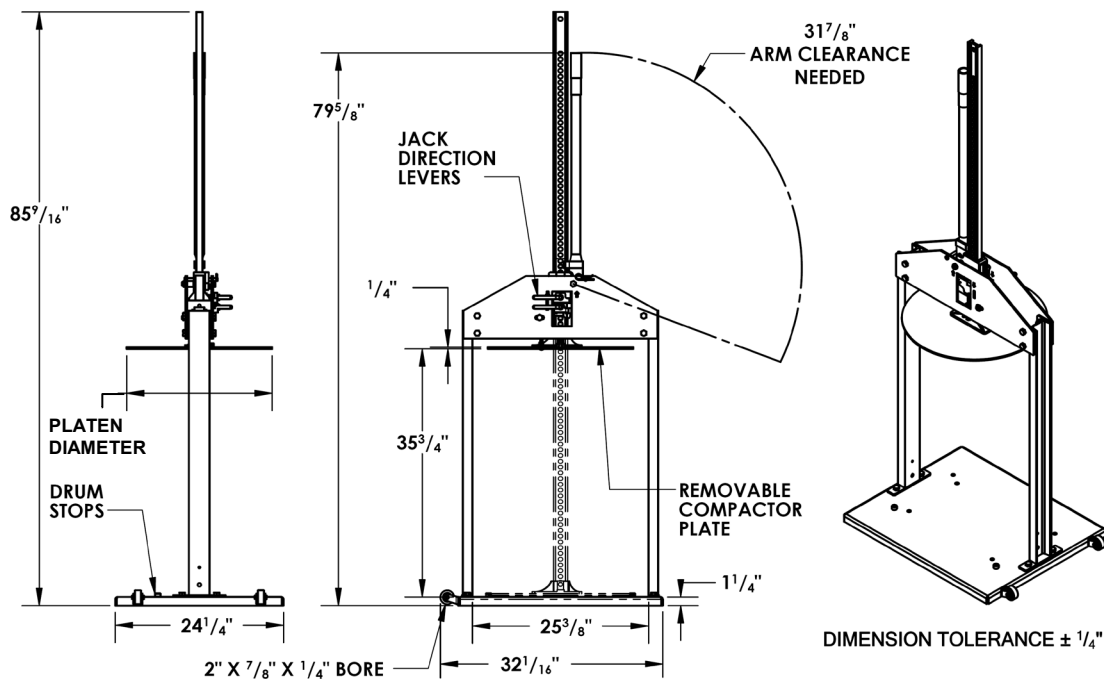

Model	Platen Diameter	Maximum Compacting Force	Net Weight
MTC-30	17" 43.2 cm	7000 lb. ~3182 kg	158 lb. 71.7 kg
MTC-55	21" 53.3 cm	7000 lb. ~3182 kg	167 lb. 75.9 kg

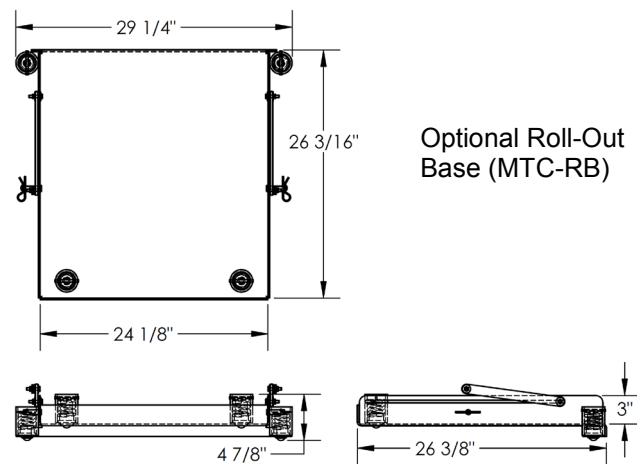

Optional Equipment		
Model	Roll-Out Load Capacity	Net Weight
MTC-RB (ROLL-OUT BASE)	800 lb. ~364kg	58 lb. 26.1 kg

**EXPLODED VIEW & BILL OF MATERIALS
(22-006-007)**

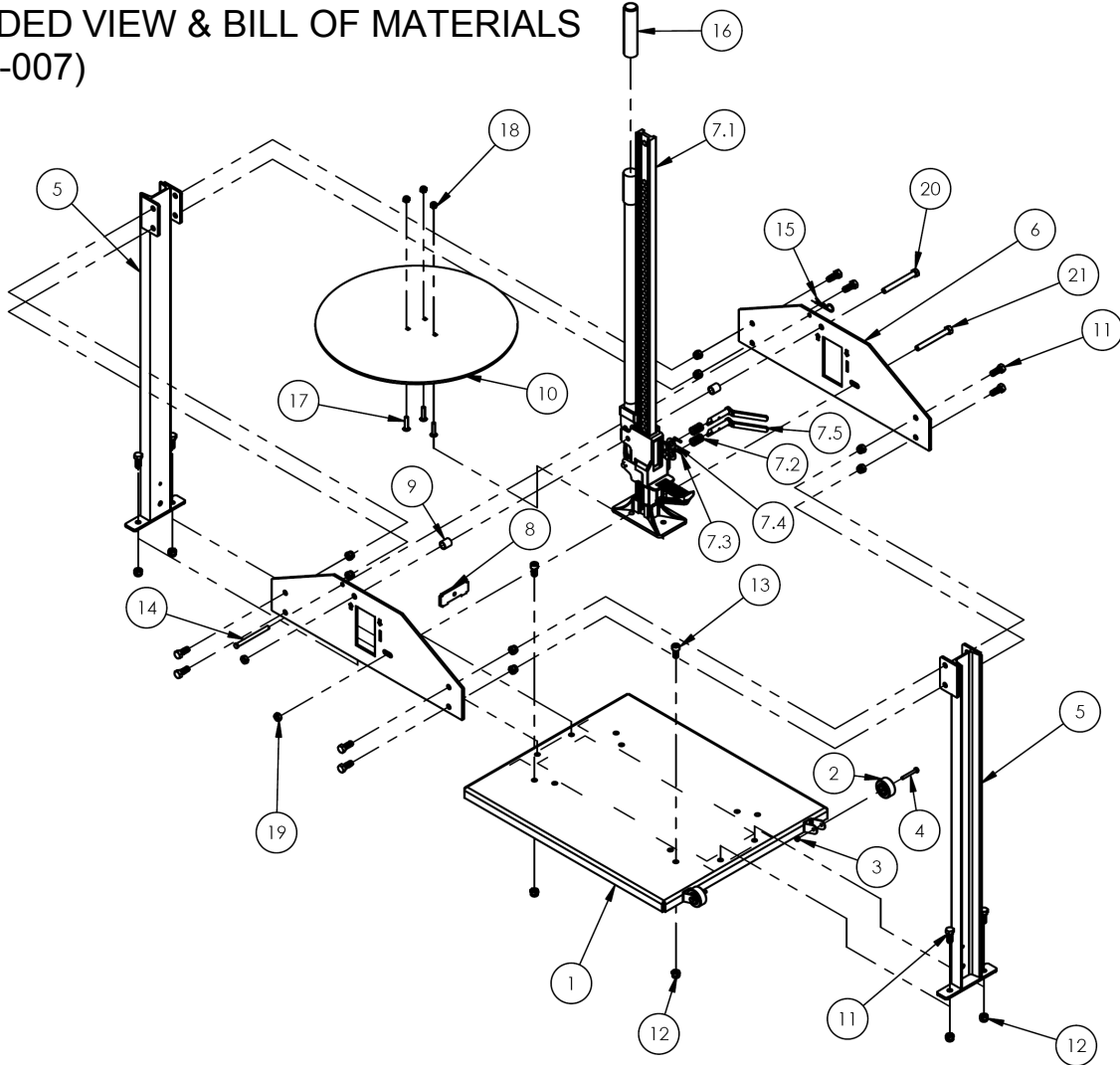

Item	Part no.	Description	Qty.	Item	Part no.	Description	Qty.
1	22-514-018	WELDMENT, BASE	1	9	22-113-004	SPACER, JACK	2
2	16-132-225	Ø2" X 7/8" X 1/4" BORE RBR. WHEEL	2	10	22-014-049 22-014-050	MTC-30 COMPACTOR PLATE MTC-55 COMPACTOR PLATE	1 1
3	37018	NYLON LOCK NUT, GRADE 2, ZINC FINISH, 1/4"-20	2	11	11207	HHCS #2 Z Plated, Ø1/2 - 13 x 1 1/4 LG	12
4	11011	HEX BOLT, GRADE A, ZINC PLATED, 1/4"-20 X 2"	2	12	37030	1/2"-13 NYLON INSERT LOCK NUT	14
5	22-514-019	WELDMENT, VERTICAL SUPPORT	2	13	93405	SOCKET HEAD CAP SCREW, ZINC PLATED, 1/2"-13 X 1"	2
6	22-016-024	BRACKET, FRONT JACK SUPPORT	2	14	99-112-006	PIN, CLEVIS	1
7	22-543-001	SUB-ASSEMBLY, JACK	1	15	45286	#11 HITCH PIN CLIP, Ø1/8" X 2 5/8 LG	1
7.1	22-043-001	FARM JACK	1	16	07-025-005	HANDLE, BLACK RUBBER, 6"	1
7.2	22-146-003	SPRING, COMPRESSION	2	17	21259	BOLT, CARRIAGE, GRADE A, ZINC FINISH, 5/16"-18 UNC x 1 1/2"	3
7.3	40577	M5 x 26mm Heavy Duty Plain Finish Metric Spring Pin	2	18	37021	NYLON INSERT LOCK NUT, GRADE 2, ZINC FINISH, 5/16"-18	3
7.4	33088	WASHER, CARBON STEEL, ZINC FINISH, 9/16"	2	19	37032	1/2" NYLON INSERT JAM NUT	2
7.5	22-612-003	WELDMENT, PIN W/ HANDLE	2	20	15221	GR.8 Z PLATED 1/2"-13 x 4 1/2" LG HHCS	1
8	22-016-029	BRACKET, JACK CENTER SUPPORT	1	21	11221	BOLT, HEX HEAD, Ø 1/2 - 13 UNC X 4 1/2 LG	1

ASSEMBLING THE COMPACTOR

Numbers in parentheses correspond to item numbers in the diagrams. The appearance of parts in the diagrams might differ from their actual appearances.

Step 1: Fasten wheels (2) to their brackets on the base plate (1) using $\frac{1}{4}$ -20 x $1\frac{1}{2}$ " bolts (4) and $\frac{1}{4}$ -20 Nylock nuts (3). Bolt the vertical supports (5) onto the base plate using $\frac{1}{2}$ -13 x $1\frac{1}{4}$ " bolts (11) and $\frac{1}{2}$ -13 Nylock nuts (12). See FIG. 1.

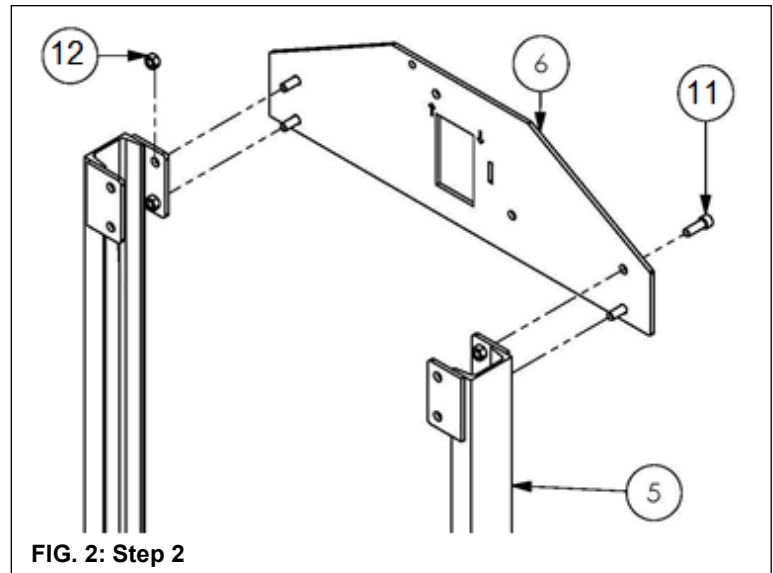
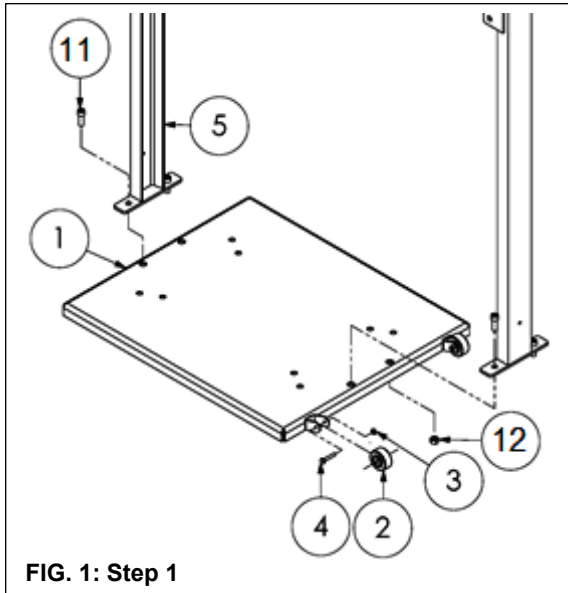

Step 2: As shown in FIG. 2, fasten a jack plate (6) onto vertical supports (5) using bolts (11) and Nylock nuts (12). Labels on the jack plate must face outward to be visible to users.

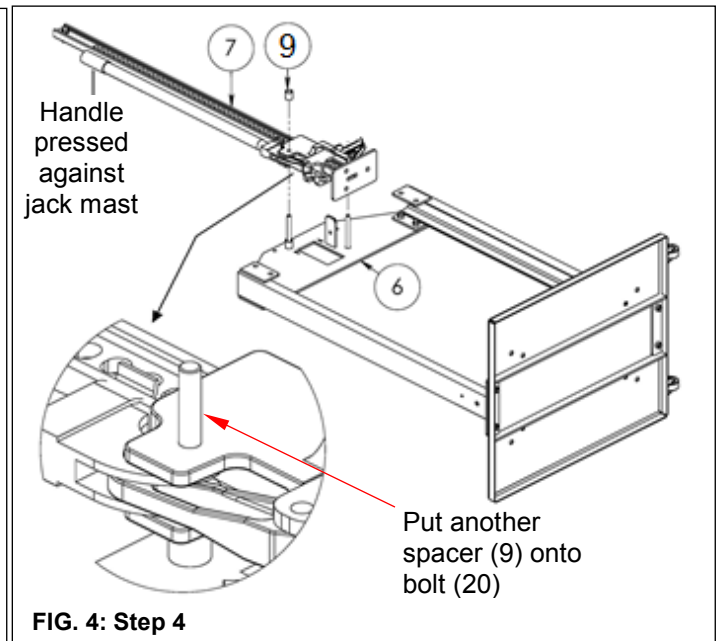
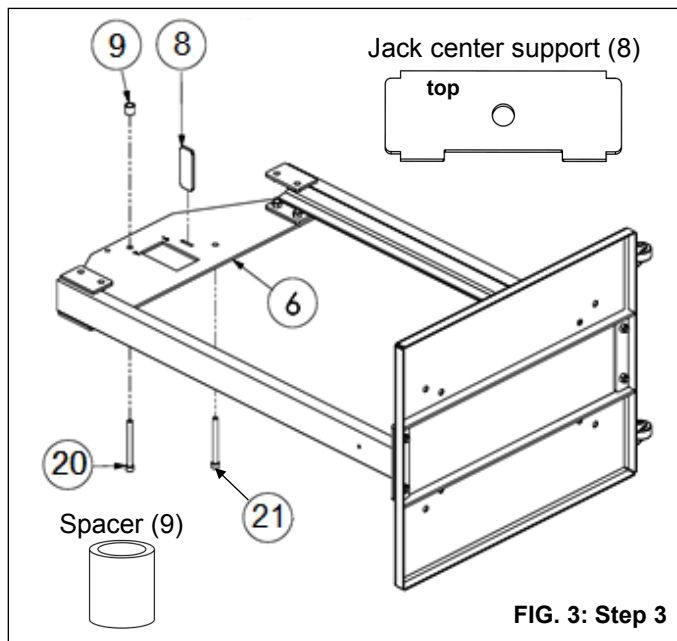

Step 3: Lay the partially assembled unit on its side as shown in FIG. 3. Insert bolts (20 & 21) through the holes in the jack plate (6). Slide a spacer (9) onto the top bolt (20). Insert the jack center support (8) into the slot.

Step 4: **[NOTE: Press the handle against the jack mast in order to properly connect the jack to the frame.]** Guide the bolts (20 & 21) through the corresponding openings in the jack as shown in FIG. 4. Then, slide the remaining spacer (9) onto the top bolt (20). If correctly installed, the top bolt will project through the holes in the jack body and jack handle as shown in the enlarged view in FIG. 4.

Step 5: Fasten the second jack plate (6) onto the vertical supports using bolts (11) and Nylock nuts (12). Make sure the jack center support aligns with the slot in the plate. Put lock nuts on the ends of bolts 20 & 21.

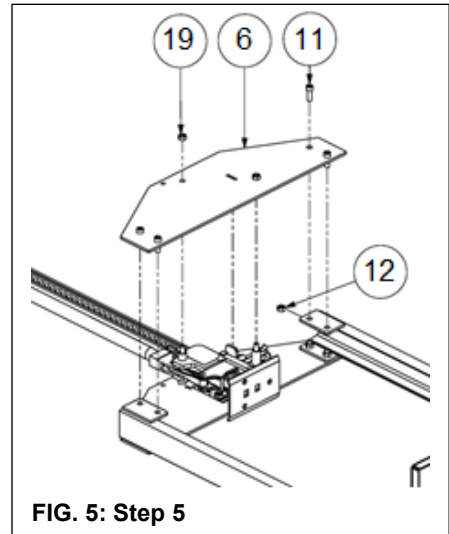

FIG. 5: Step 5

Step 6: Connect the compactor plate (10) to the end of the jack with 3 carriage bolts (17) and Nylock nuts (18). Warning labels on the plate should face up. Install two bolts (13) in the holes in the base plate that correspond to your drum volume (55gal. or 30gal.) and secure them with lock nuts (12). The inside holes (B) are for 30 gallon drums. Outer holes (A) are for 55 gallon drums. Install both bolts through the same labeled holes (A or B) in either the front or the back of the base plate.

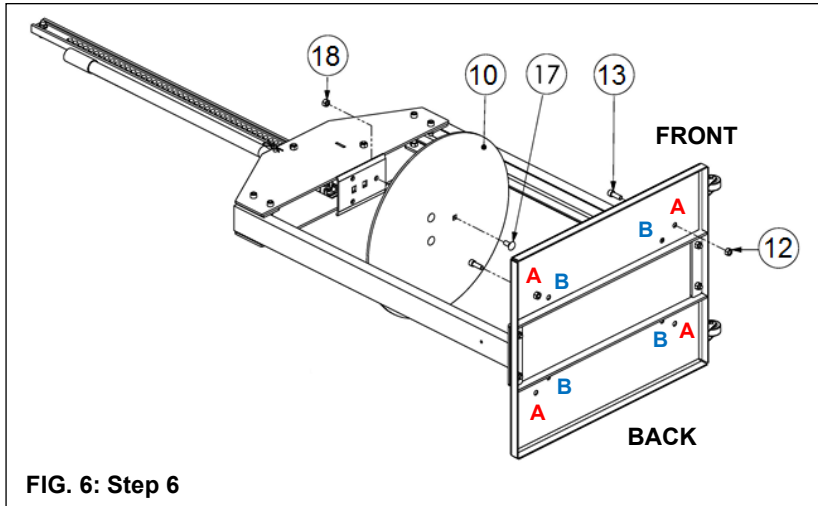

FIG. 6: Step 6

Step 7: Put the handle in an upright position. Insert the clevis pin (14) into the top holes of the jack plates when unit is not in use. Lock the pin in place with the hitch clip (15). See FIG. 7. The handle should also be secured whenever the compactor is not in use.

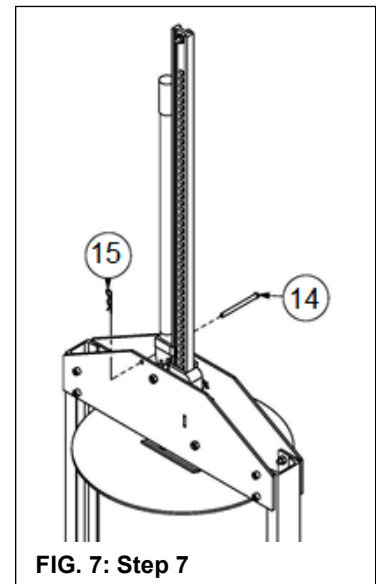

FIG. 7: Step 7

Assembling Optional Roll-Out Base MTC-RB

Refer to the [Exploded View](#) and [Assembly Diagrams](#) on p. 6 as well as FIG. 8.

Numbers in parentheses () correspond to item numbers in the MTC-RB [Exploded View](#) on p. 6.

Step 8: Attach one end of each link (2) to the slots in the MTD-RD tray using bolts (3), washers (4), and lock nuts (5). NOTE: Three washers are used. Pay attention to washer locations in the [Exploded View](#) on p. 6.

Step 9: Attach the free ends of the links to the upper bolt holes (A) in the vertical supports with hardware (3, 4, & 5). NOTE: Three washers are used. Pay attention to washer locations in the [diagram](#) on p. 6.

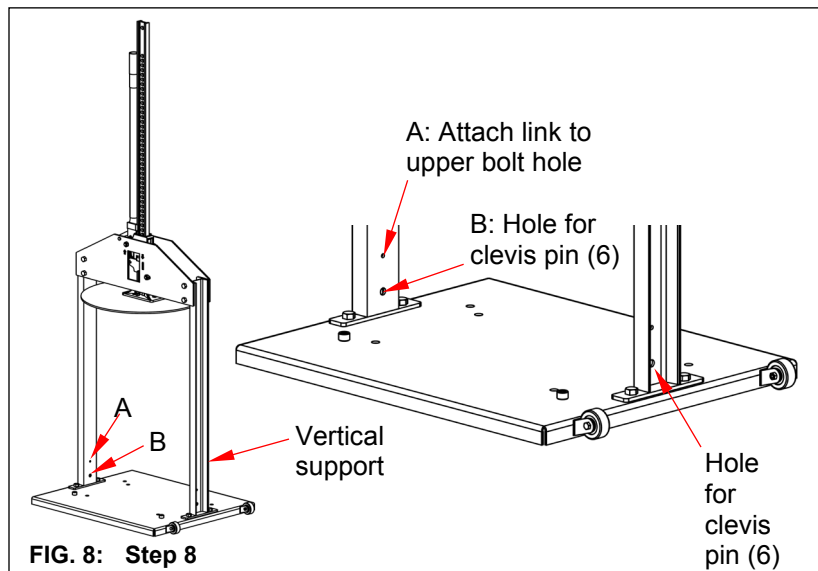
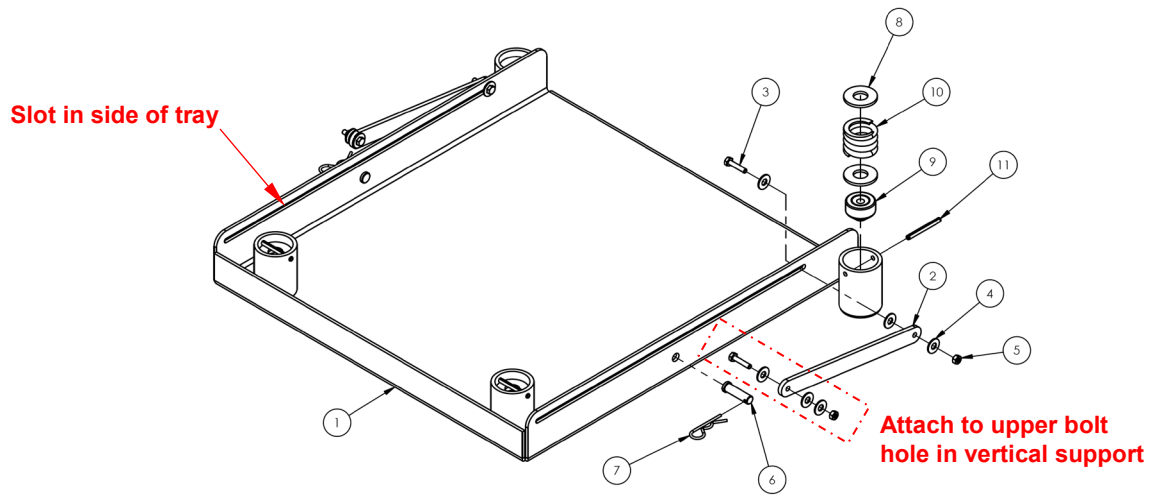

FIG. 8: Step 8

Step 10: Lock the roll-out tray to the frame. Insert clevis pins (6) through the bottom holes (B) of the vertical supports and through the hole on the roll-out tray when moving unit. See [FIG. 8](#).

Exploded View: Roll-Out Base Option (MTC-RB)



Item	Part no.	Description	Qty.	Item	Part no.	Description	Qty.
1	22-514-020	Subassembly, deck/tray	1	7	45286	#11 hitch pin clip, 1/8" x 2 5/8"	2
2	22-016-077	Frame, link	2	8	22-114-001	Washer, flat, finished	8
3	11007	1/4"-20UNC x 1 1/4" hex bolt	4	9	22-027-001	Ball transfer, machined	4
4	33006	5/16" flat washer	12	10	22-146-004	Spring, compression	4
5	37018	1/4"-20, Nylon lock nut, grade 2, zinc finish	4	11	64257	Spring pin, 1/4" x 2 1/2"	4
6	21-112-003	1/2" x 1 15/16" clevis pin	2				

MTC-RB Assembly Diagrams

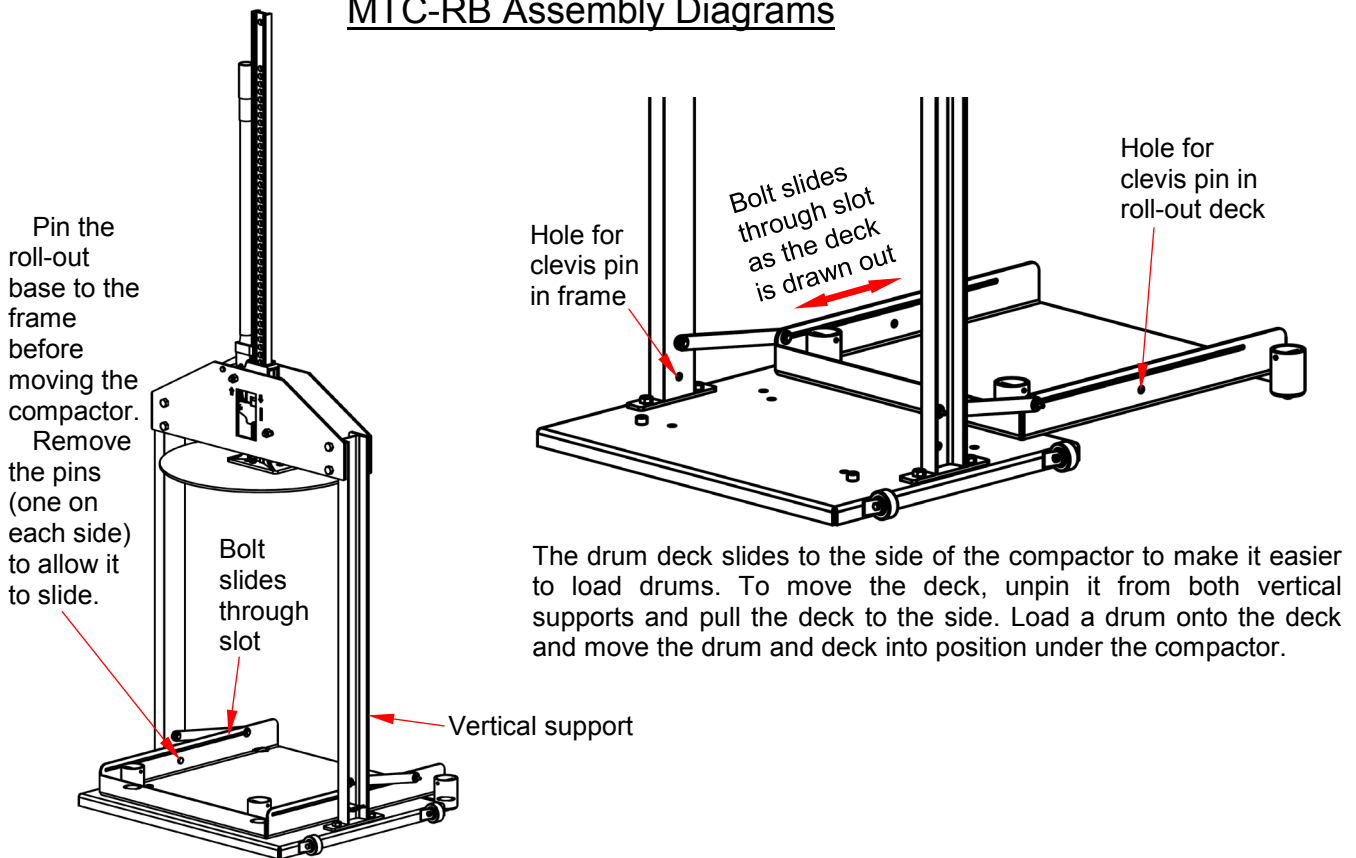

Using the Compactor

Read the entire manual before putting the compactor into service. If questions remain after you finish reading the manual, contact [Technical Service](#) for answers.

⚠ WARNING Improper operation could result in serious personal injuries.

- DO NOT compact contents inside a drum that is damaged. E.g. severely rusted or corroded
- ALWAYS inspect the compactor and the drum BEFORE each use. Follow the [Maintenance & Inspections](#) procedures provided on p. 8. Only use the compactor if it is in [Original Condition](#).
- The drum might be too heavy for 1 person to maneuver. Ask someone to help you.
- NEVER modify the compactor in any way without express, written approval from Vestil. Unapproved modifications automatically void the [Limited Warranty](#) and might make the compactor unsafe to use.
- Keep fingers and hands away from the drum rim and the compactor platen while it is moving.
- DO NOT stand directly in line with the handle. DO NOT lean over the handle while operating the jack. The handle could recoil upwards out of your hands if the handle is not pressed all the way down during each stroke.

Step A: Free the jack handle by removing the storage pin (14). See [FIG. 7](#) on p. 5. Turn the jack direction levers to UP position and fully raise the compactor plate. Refer to [FIG. 9](#)

MTC-RB units: Remove the pins securing the roll-out tray to the frame. See [FIG. 8](#) on p. 5.

Step B: Center the drum under the platen.

MTC-RB units: Roll out tray. Place drum on tray and push the tray under jack. Center drum under the platen.

Step C: Turn the jack direction levers to the DOWN position.

Step D: Stand to one side of the jack handle. Lower the compactor platen by moving the handle up and down. Fully raise and fully lower the handle. This is necessary for the ratchet mechanisms of the jack to properly interact.

Step E: Lower the compactor platen into contact with the waste material. Continue ratcheting the jack until the desired degree of compaction is achieved. **NOTE:** To achieve optimum compression, compact waste materials frequently. Materials will not compact as completely or easily if the drum is full or mostly full.

Step F: Once compaction is adequate, turn both direction levers to the UP position.

Step G: Raise the compactor platen high enough to remove the drum or until the platen is fully raised.

Step H: Put the jack handle in the storage position and secure it with the clevis pin (11) and hitch pin (12). See [FIG. 7](#) on p. 5.

Step I: Remove the drum. **MTC-RB model:** Pull the drum out from under the platen. Remove the drum. Push the tray back onto the base plate. Be certain to reinstall the clevis pins and hitch pins. See [FIG. 8](#) on p. 5.

Step J: Store the compactor in a dry, indoor location. Keep the device dry at all times.

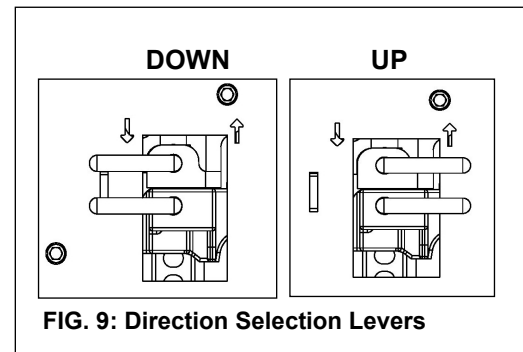

Labeling Diagram

The unit should be labeled as shown in the diagram. However, label appearance, content, and location are subject to change so your product might not be labeled exactly as shown. Replace all labels that are damaged, missing, or not easily readable (e.g. faded). Order replacement labels by contacting [Technical Service](#) online at http://www.vestilmfg.com/parts_info.htm. Alternatively, you may request replacement parts and service by calling (260) 665-7586 and asking the operator to connect you to the Technical Service Department.

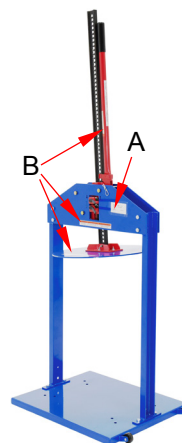

A: Data label (Model, Serial #, Capacity, Date)

MODEL/MODELO/MODELE	_____
STATIC CAPACITY (evenly distributed)	_____ lbs.
LA CAPACIDAD CONSTANTE (distribuida uniformemente)	_____ kgs.
CAPACITÉ STATIQUE (distribuée régulièrement)	_____ kgs.
SERIAL/SERIE/SERIE	_____
	287 REV.03/13

B: Label 208 (both jack plates; on top of platen; on jack handle)

⚠ WARNING	⚠ ADVERTENCIA	⚠ AVERTISSEMENT
KEEP CLEAR OF PINCH POINT	MANTENGASE ALEJADO DEL PUNTO DE CORTE	SE TENIR À DISTANCE DU POINT DE PINCEMENT

Moving the Compactor

⚠ WARNING

Carelessness while moving the compactor might result in personal injuries.

- DO NOT move the compactor while it is loaded. Unload the compactor before moving it.
- Secure the jack handle in the storage position with clevis pin & hitch pin before moving the compactor. See [Step 7](#) on p. 5.
- [Units with MTC-RB] Secure the roll-out tray as described in [Step 10](#) on p. 5 before moving the unit.

Step 1: Stand to the side of the unit where the wheels are mounted. Grasp the jack and jack handle. See FIG. 10.

Step 2: Tilt the unit towards you until the wheels contact the ground.

Step 3: Push the compactor to desired location. Slowly lower the raised side until it rests on the ground.

Record of Original Condition

Make a record of the unit in its original condition before putting it into service. Thoroughly photograph the assembled compactor from all sides. Include close range photos of the following: Each label applied to the unit; the direction selection levers; all fasteners and pins; the platen; the jack plates; and the base plate. Raise and lower the platen. Describe the motion of the jack as well as how it sounds while the ratchet mechanism operates. Collate all documentation and photographs. This record establishes "original condition". Compare the results of every inspection to this record. Repair or replace all parts that no longer are in original condition. Purely cosmetic changes are not changes from original condition. However, touchup paint should be applied to all areas where the surface coating is damaged as soon as the damage occurs.



FIG. 10 Moving Unit

Maintenance & Inspections

Regular maintenance is essential to keep the compactor in *original condition*.

Maintenance:

Implement a maintenance program to ensure that the compactor remains in original condition.

Step 1: Tag the compactor, "Out of Service."

Step 2: Conduct the appropriate inspection (Before each use or Periodic).

Step 3: Perform all other necessary adjustments and/or repairs. DO NOT use the compactor until it has been repaired with approved replacement parts. Contact [Technical Service](#) for assistance if you discover conditions during an inspection that are not addressed in this manual or with any other questions that arise during use or inspections.

Step 4: Make a dated record of all repairs, adjustments and replacements.

Inspections:

A. **Before each use** — Examine the jack for either of the following:

1. Frame damage/deformation;
2. Abnormal function: ratchet the compactor plate up and down

B. **Periodic** — Inspect the following components at least once per month for corrosion, damage, excessive wear or rusting, and noisy or rough operation:

1. Compactor platen
2. Jack front and back plates
3. Base plate
4. Jack and jack handle
5. Fasteners (bolts, nuts, clevis pins and hitch pin)
6. Labels. See [Labeling Diagram](#) on p. 6.

LIMITED WARRANTY

Vestil Manufacturing Corporation (“Vestil”) warrants this product to be free of defects in material and workmanship during the warranty period. Our warranty obligation is to provide a replacement for a defective, original part covered by the warranty after we receive a proper request from the Warrantee (you) for warranty service.

Who may request service?

Only a warrantee may request service. You are a warrantee if you purchased the product from Vestil or from an authorized distributor AND Vestil has been fully paid.

Definition of “original part”?

An original part is a part used to make the product as shipped to the Warrantee.

What is a “proper request”?

A request for warranty service is proper if Vestil receives: 1) a photocopy of the Customer Invoice that displays the shipping date; AND 2) a written request for warranty service including your name and phone number. Send requests by one of the following methods:

US Mail	Fax	Email
Vestil Manufacturing Corporation 2999 North Wayne Street, PO Box 507 Angola, IN 46703	(260) 665-1339 <u>Phone</u> (260) 665-7586	info@vestil.com Enter “Warranty service request” in subject field.

In the written request, list the parts believed to be defective and include the address where replacements should be delivered. After Vestil receives your request for warranty service, an authorized representative will contact you to determine whether your claim is covered by the warranty. Before providing warranty service, Vestil will require you to send the entire product, or just the defective part (or parts), to its facility in Angola, IN.

What is covered under the warranty?

The warranty covers defects in the following original, dynamic parts: motors, hydraulic pumps, motor controllers, and cylinders. It also covers defects in original parts that wear under normal usage conditions (“wearing parts”), such as bearings, hoses, wheels, seals, brushes, and batteries.

How long is the warranty period?

The warranty period for original dynamic components is 30 days. For wearing parts, the warranty period is 30 days. Both warranty periods begin on the date Vestil ships the product to the Warrantee. If the product was purchased from an authorized distributor, the periods begin when the distributor ships the product. Vestil may, at its sole discretion, extend a warranty period for products shipped from authorized distributors by up to 30 days to account for shipping time.

If a defective part is covered by the warranty, what will Vestil do to correct the problem?

Vestil will provide an appropriate replacement for any *covered* part. An authorized representative of Vestil will contact you to discuss your claim.

What is not covered by the warranty?

The Warrantee (you) is responsible for paying labor costs and freight costs to return the product to Vestil for warranty service.

Events that automatically void this Limited Warranty.

- Misuse;
- Negligent assembly, installation, operation or repair;
- Installation/use in corrosive environments;
- Inadequate or improper maintenance;
- Damage sustained during shipping;
- Collisions or other accidents that damage the product;
- Unauthorized modifications: Do not modify the product IN ANY WAY without first receiving written authorization from Vestil.

Do any other warranties apply to the product?

Vestil Manufacturing Corp. makes no other express warranties. All implied warranties are disclaimed to the extent allowed by law. Any implied warranty not disclaimed is limited in scope to the terms of this Limited Warranty. Vestil makes no warranty or representation that this product complies with any state or local design, performance, or safety code or standard. Noncompliance with any such code or standard is not a defect in material or workmanship.

