

IT IS RECOMMENDED  
TO USE POWER TOOLS

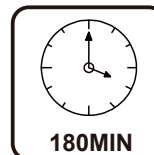

180MIN

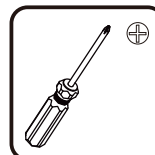
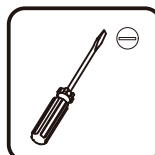
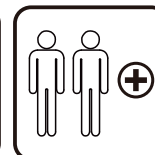

**EN\_IMPORTANT, RETAIN FOR FUTURE REFERENCE: READ CAREFULLY.**

*. THANK YOU FOR PURCHASE! .*

# FREE REPLACEMENT PARTS AVAILABLE!



*---NEED HELP WITH YOUR FURNITURE?---*

Scan the QR code to contact us!



If you're experiencing any issues—whether due to shipping, assembly, or any other reason  
—we're here to help.  
For any damaged or missing components, we're happy to provide FREE replacement parts.

## *WANT TO CONTACT US THROUGH*

- ▶ Log in to your account.
- ▶ Go to “Your Orders” and locate your furniture order.
- ▶ Click on “Get Help with Order” to send us a message directly.

Our customer support team is ready to assist you and we will respond within  
12-24 HOURS to resolve your concerns quickly!

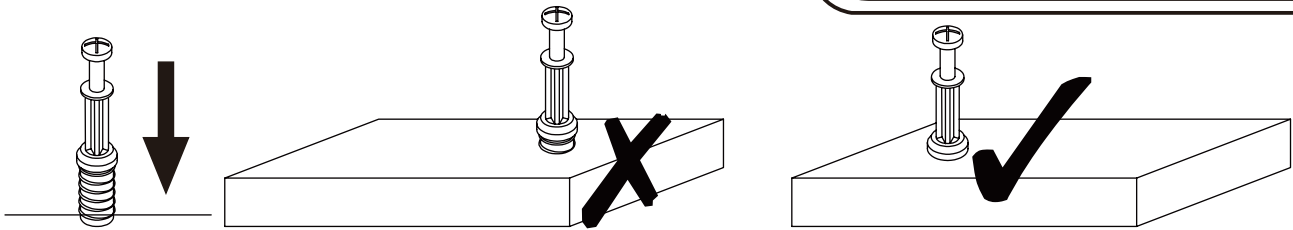

**EN\_QUICKFIT:** Tighten quickfit until shoulder is flush with panel. Do not overtighten or undertighten.

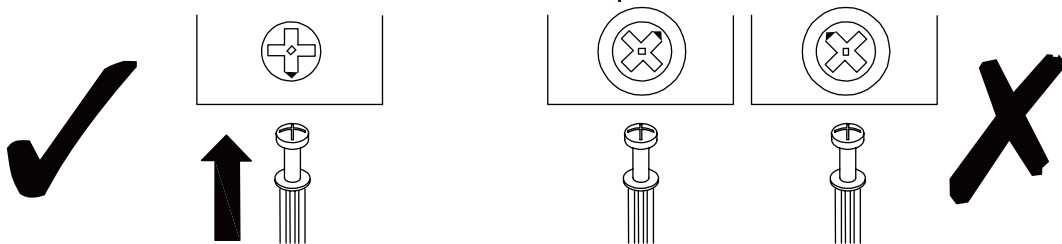



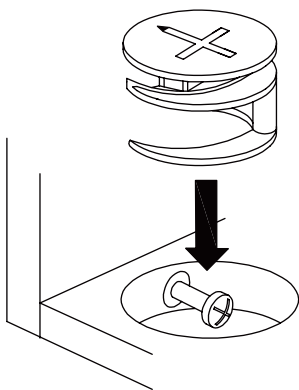

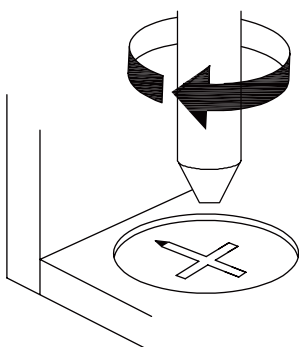

**EN\_CAM LOCK:** When fitting cam lock, ensure starting position is correct before you insert connecting quickfit.



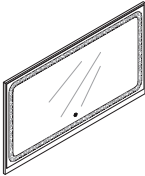
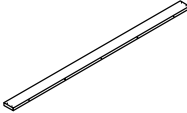

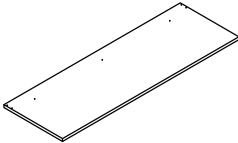

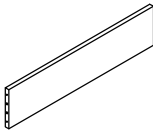
**EN\_Quickfit** head should be in the centre of the cam lock when the two panels are joined.  
Cam lock should be inserted before quickfit.



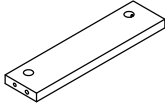
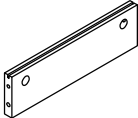

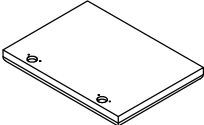
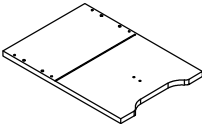
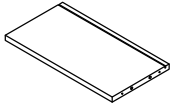
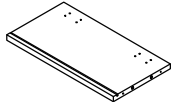
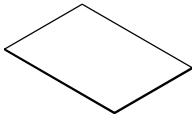
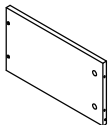
**EN\_Turn** cam lock clockwise to tighten.

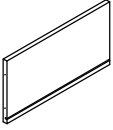
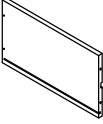
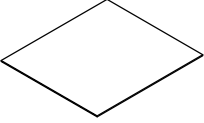
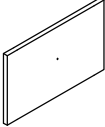
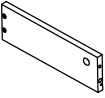
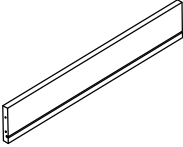
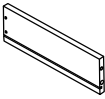
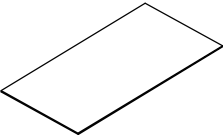
NO.	PARTS	QTY	SPARE
1		x1	
2		x1	
3		x1	
4		x1	
5		x1	
6		x1	
7		x1	
8		x1	
9		x1	
10		x1	

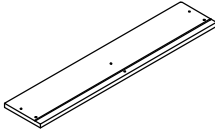
NO.	PARTS	QTY	SPARE
11		x4	
12		x2	
13		x1	
14		x1	
15		x1	
16		x2	
17		x1	
18		x1	
19		x1	
20		x6	

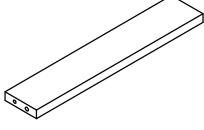
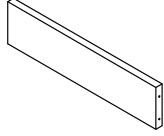
NO.	PARTS	QTY	SPARE
21		x6	
22		x6	
23		x6	
24		x6	
25		x1	
26		x1	
27		x1	
28		x1	
29		x1	
30		x1	

NO.	PARTS	QTY	SPARE
31		x1	
32		x1	
	 Hardware Kit	x1	

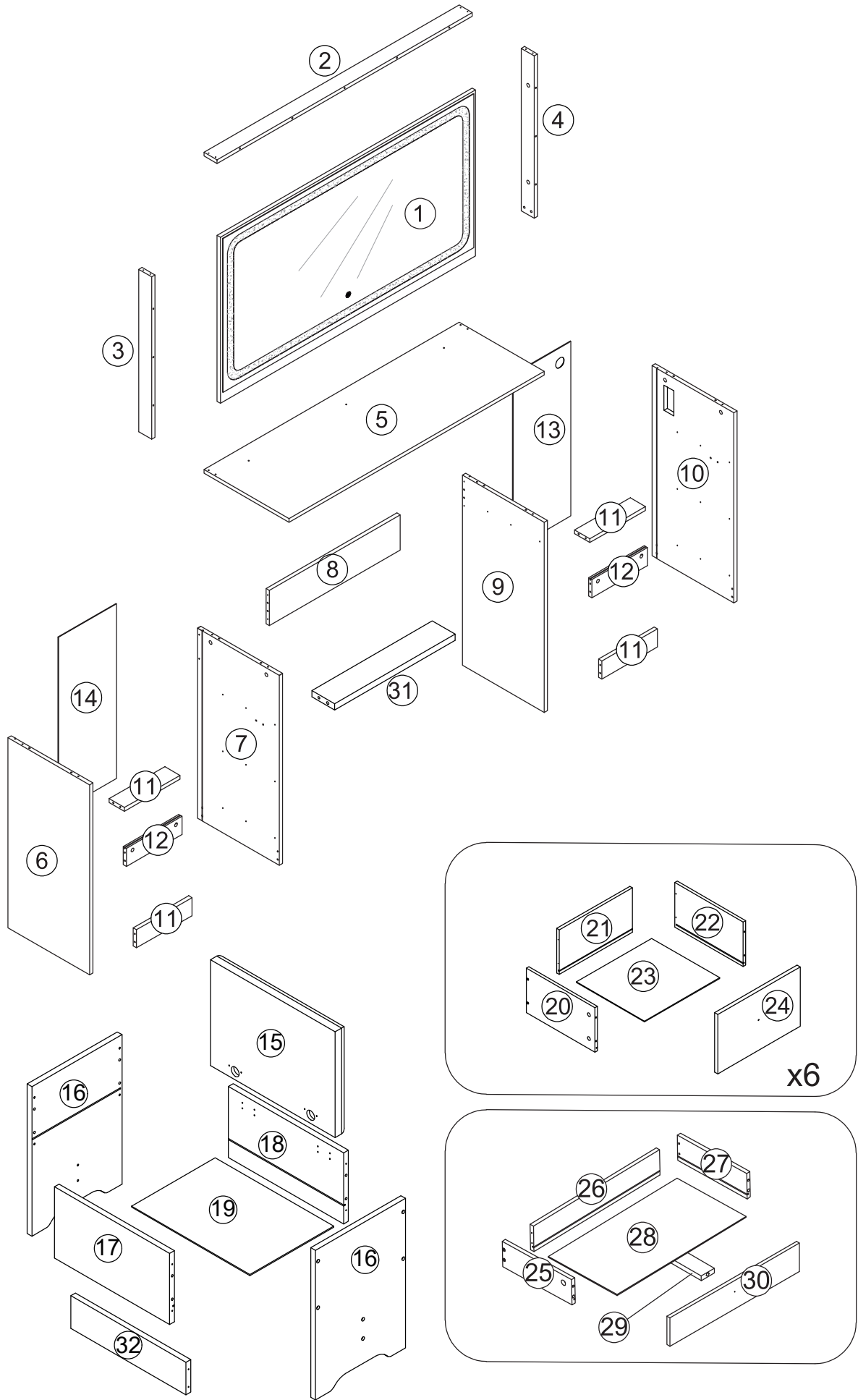



A	x56 +2(spare)	B	x56 +2(spare)	C	x38 +2(spare)	D	x55 +2(spare)	E	x84 +2(spare)	F	x7
6x35mm		15x10mm		6x30mm		4x35mm		3x12mm		6x50mm	
G	x7	H	x7	I	x2	J	x2	K	x8	L	x1
								K-1  K-2			
						4x14mm		3x16mm			
M	x1	N	x2	O	x2	P	x12	Q	x2	R	x7
		6x30mm						3.5x12mm			
S	x1	T	x1	U	x12	CL	x6	CR	x6	DL	x6
				15mm		L300mm		L300mm		L300mm	
DR	x6	CL	x1	CR	x1	DL	x1	DR	x1		
L300mm		L350mm		L350mm		L350mm		L350mm			

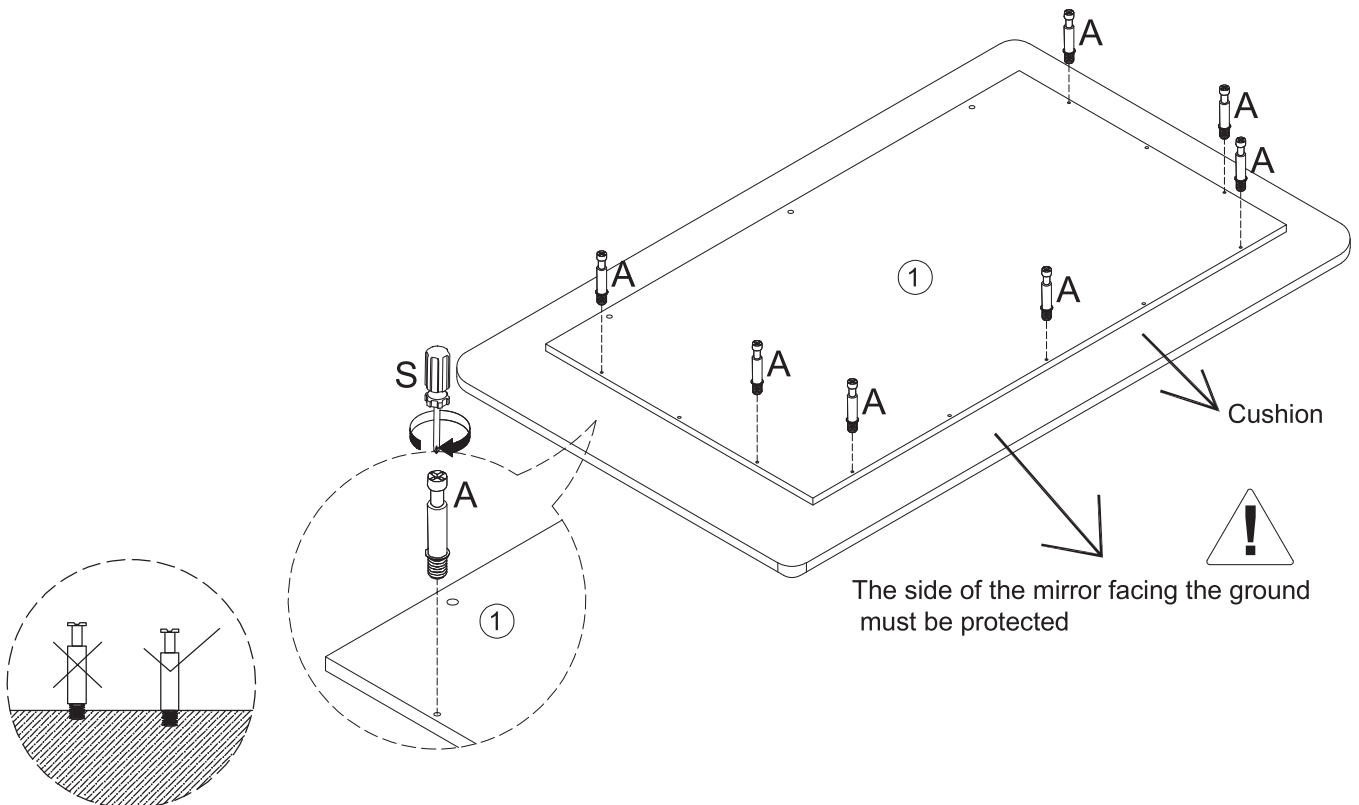

A	x7	S	x1

**01**



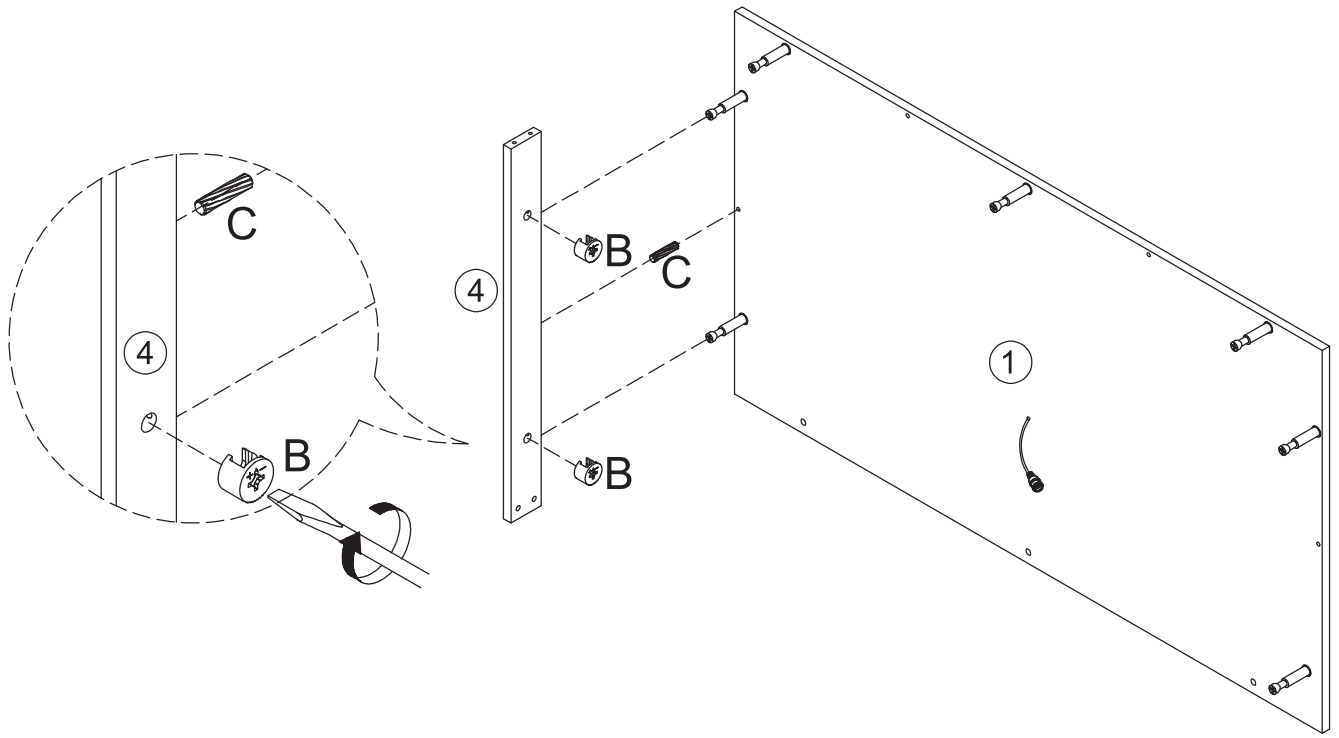

B	x2	C	x1
			

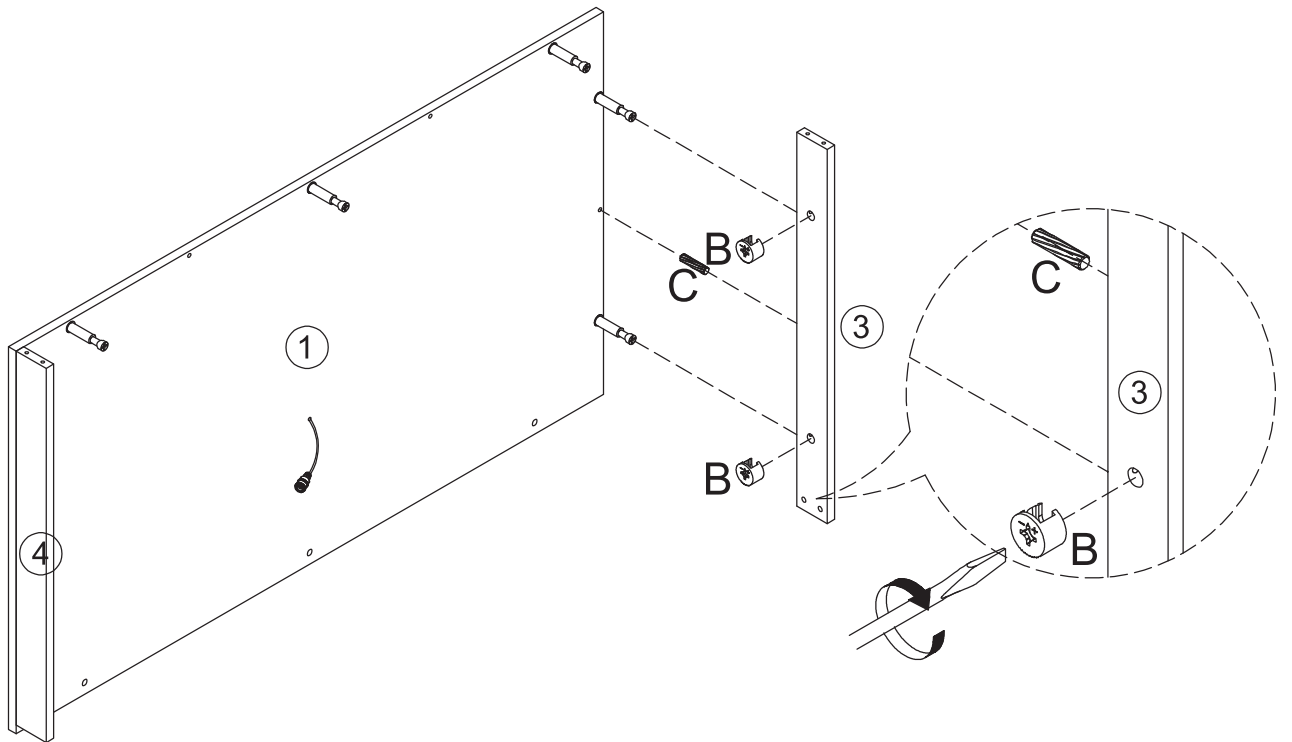

B	x2	C	x1
			

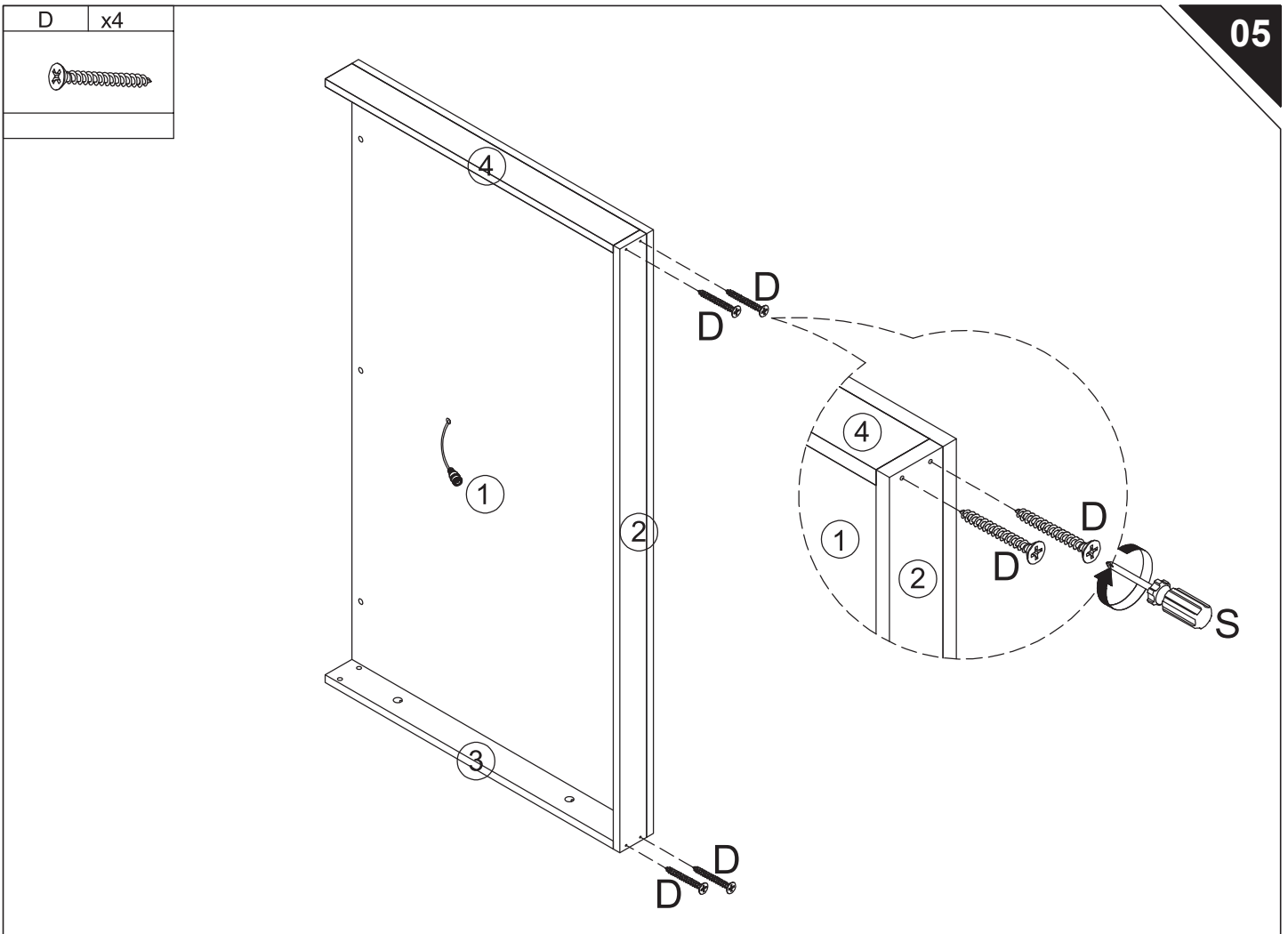
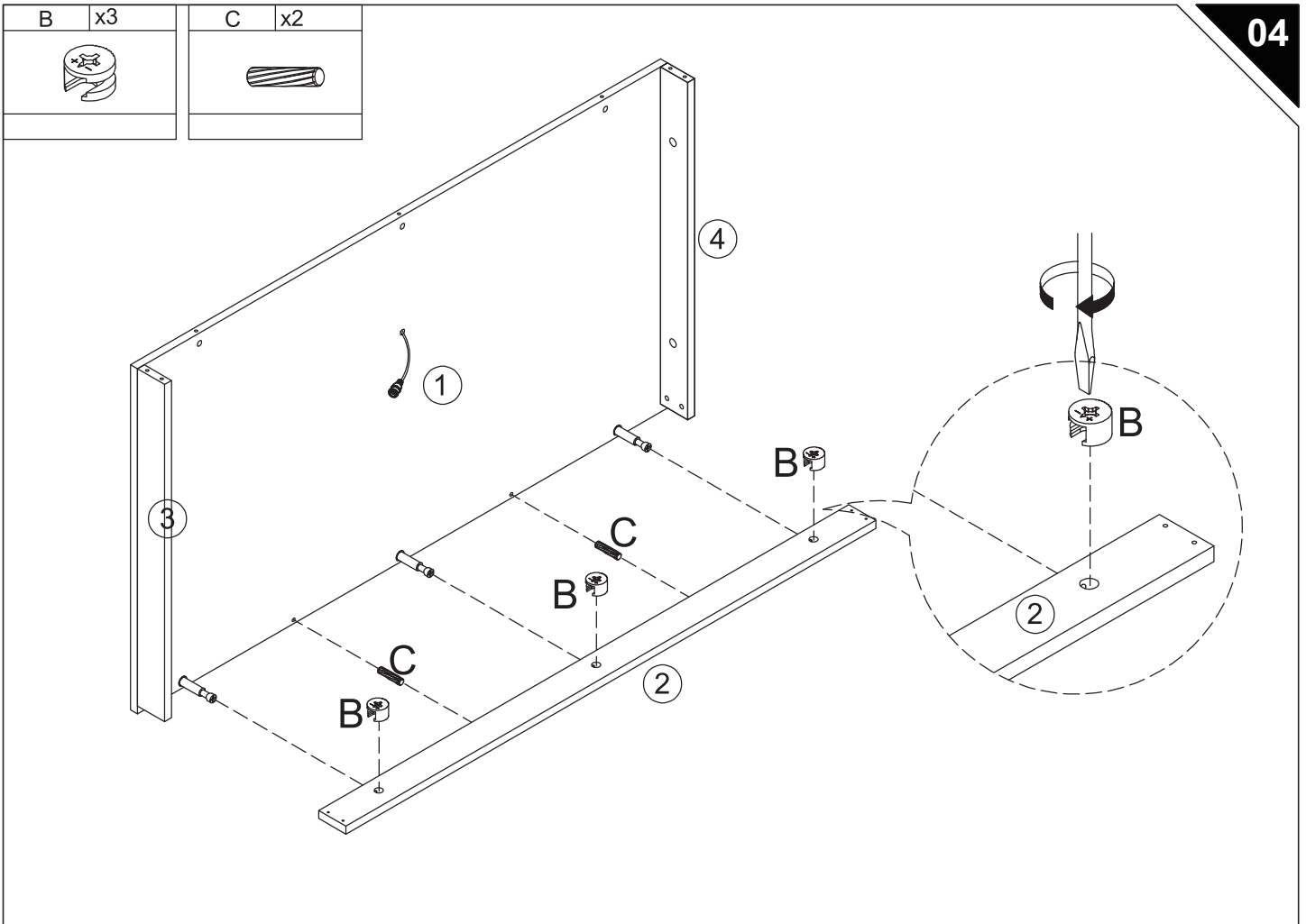



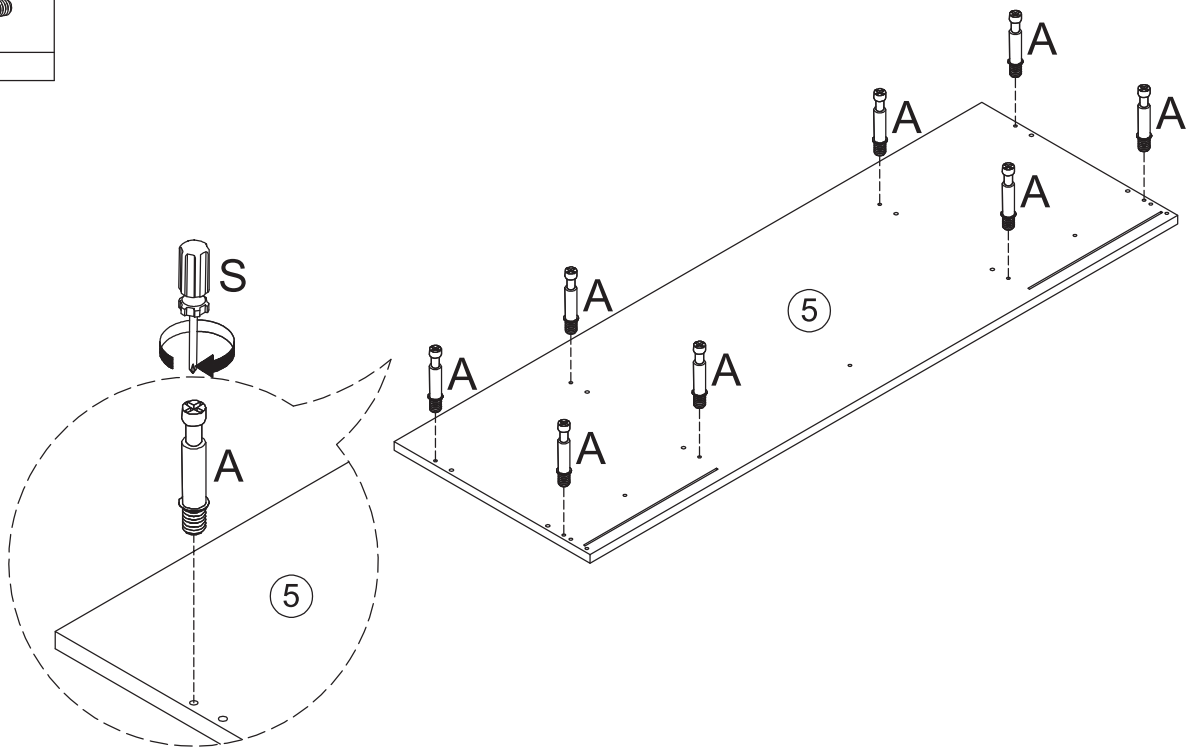

A	x8
	

06





F	x7
	

R	x7
	

T	x1
	

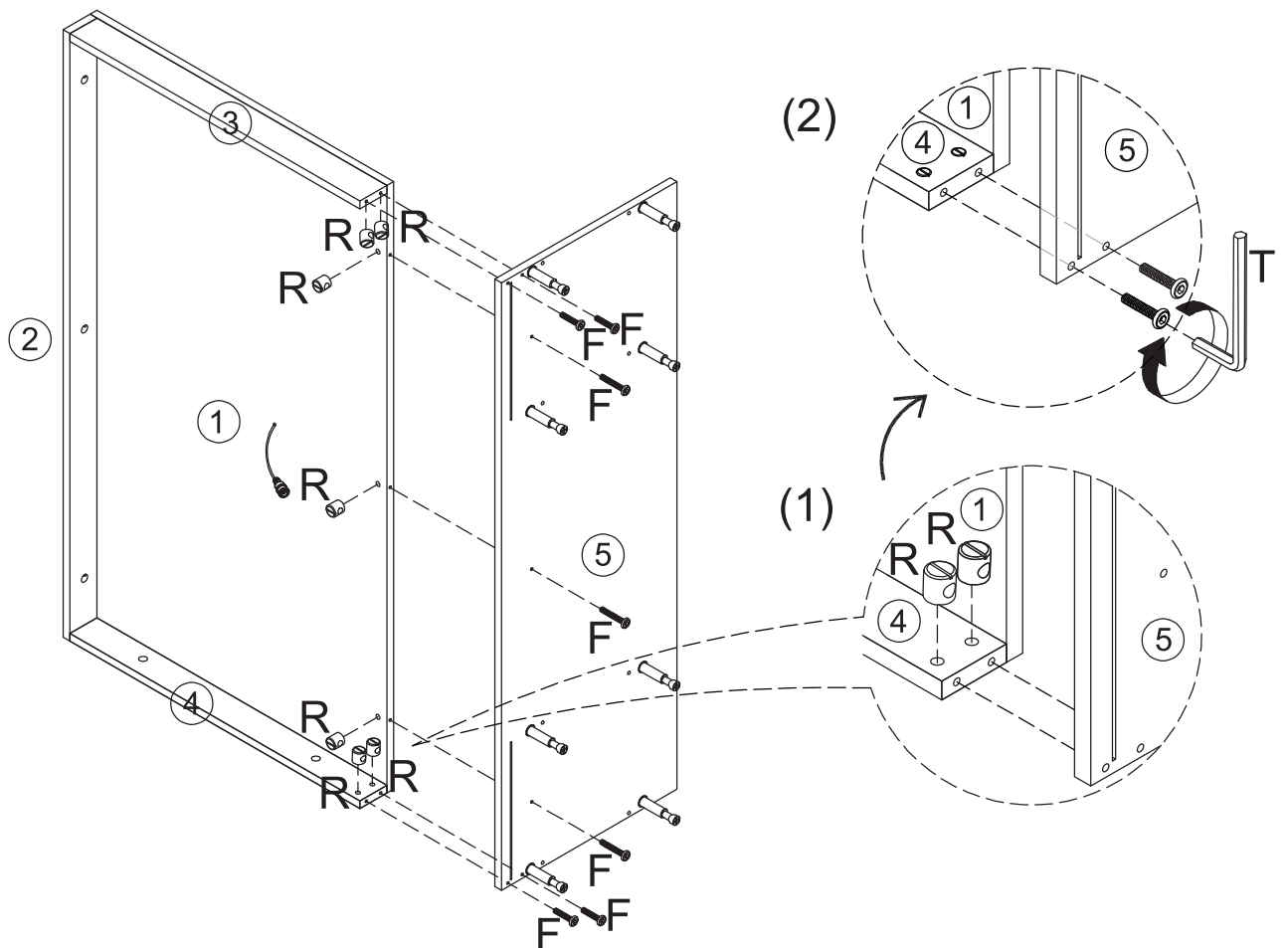
07



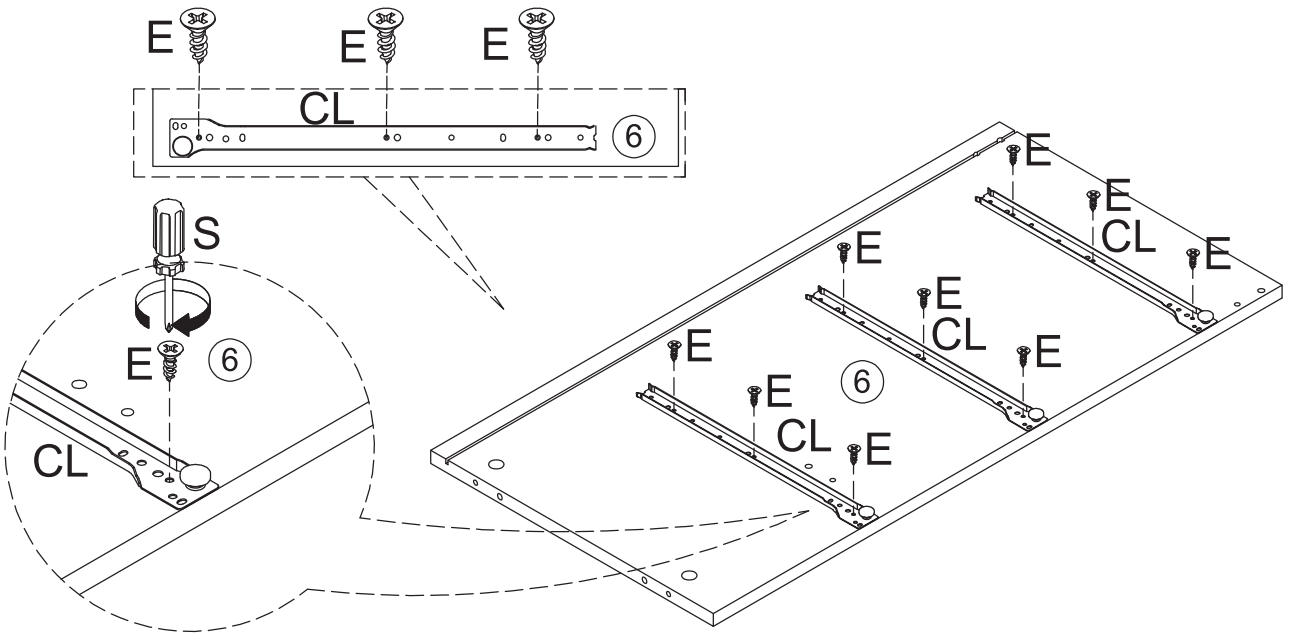

CL	x3	E	x9
			
L300mm			



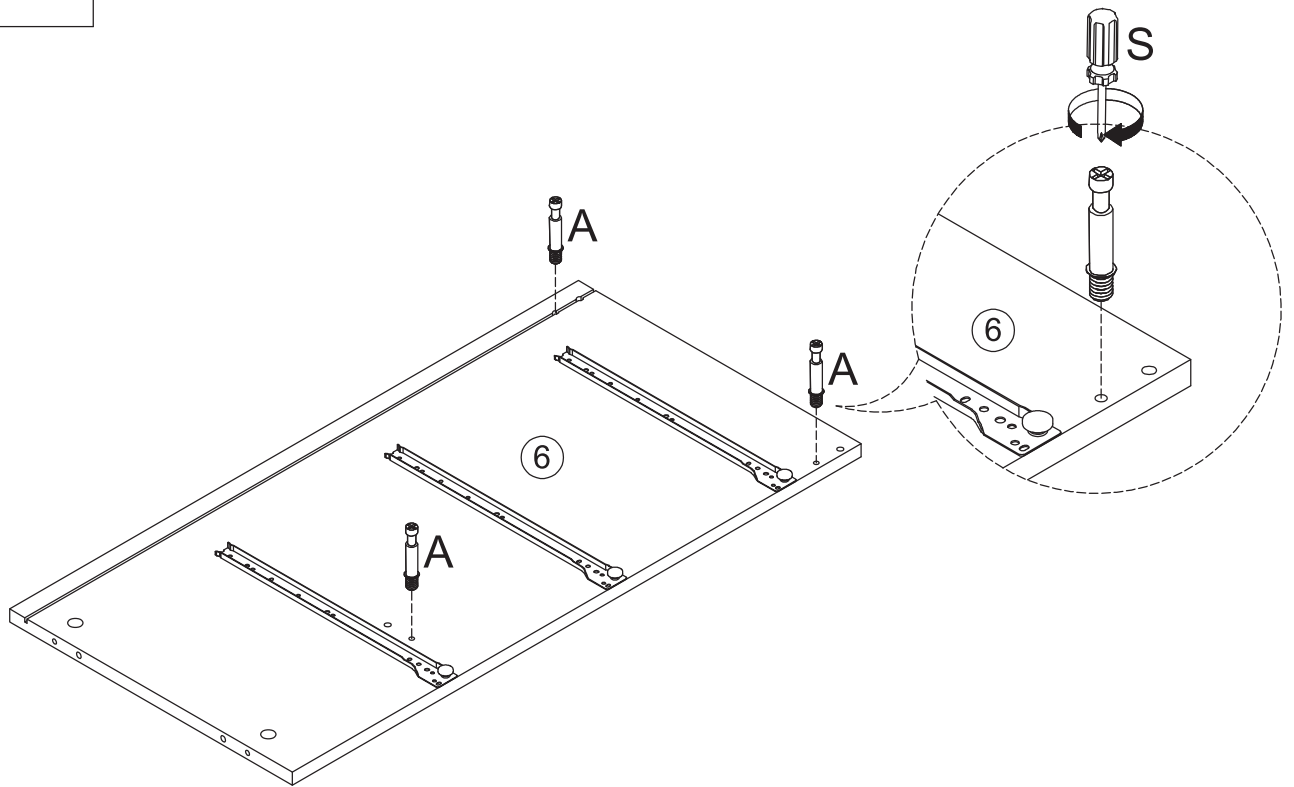

 Attention,  
First hole

A	x3
	



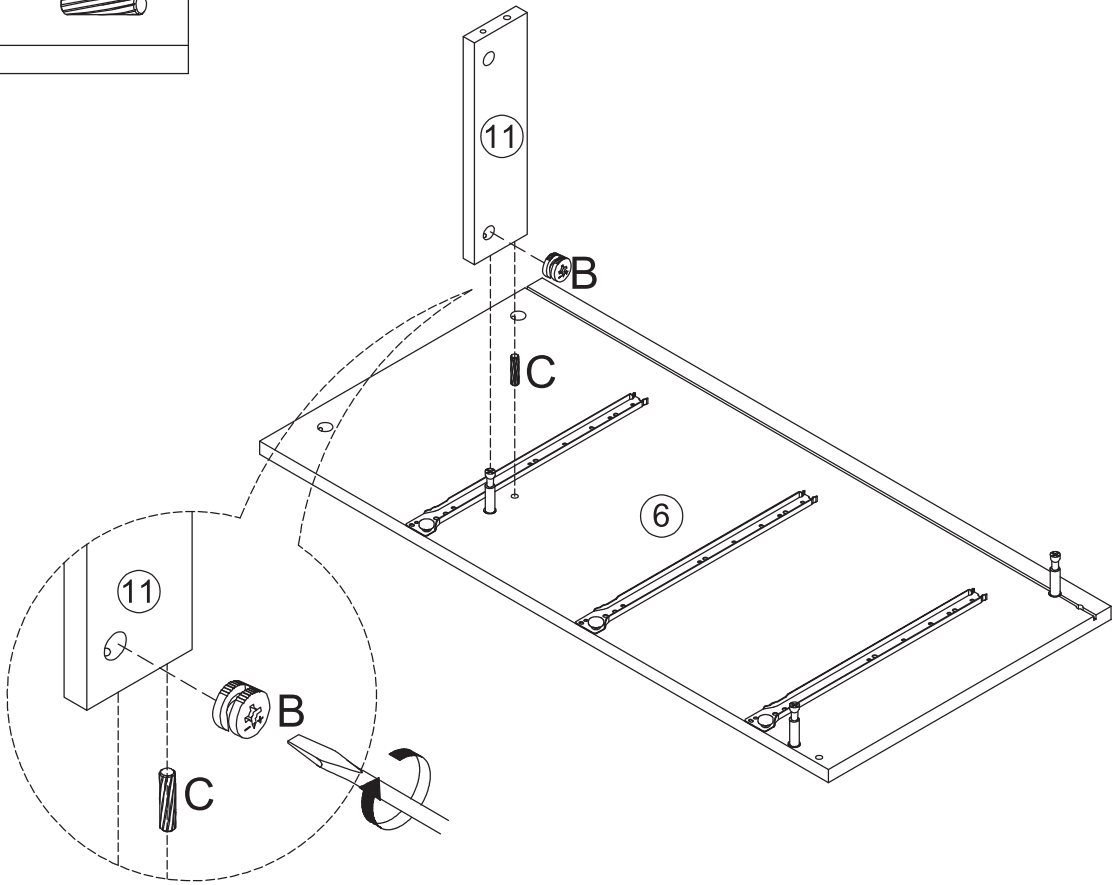



B	x1	C	x1
			

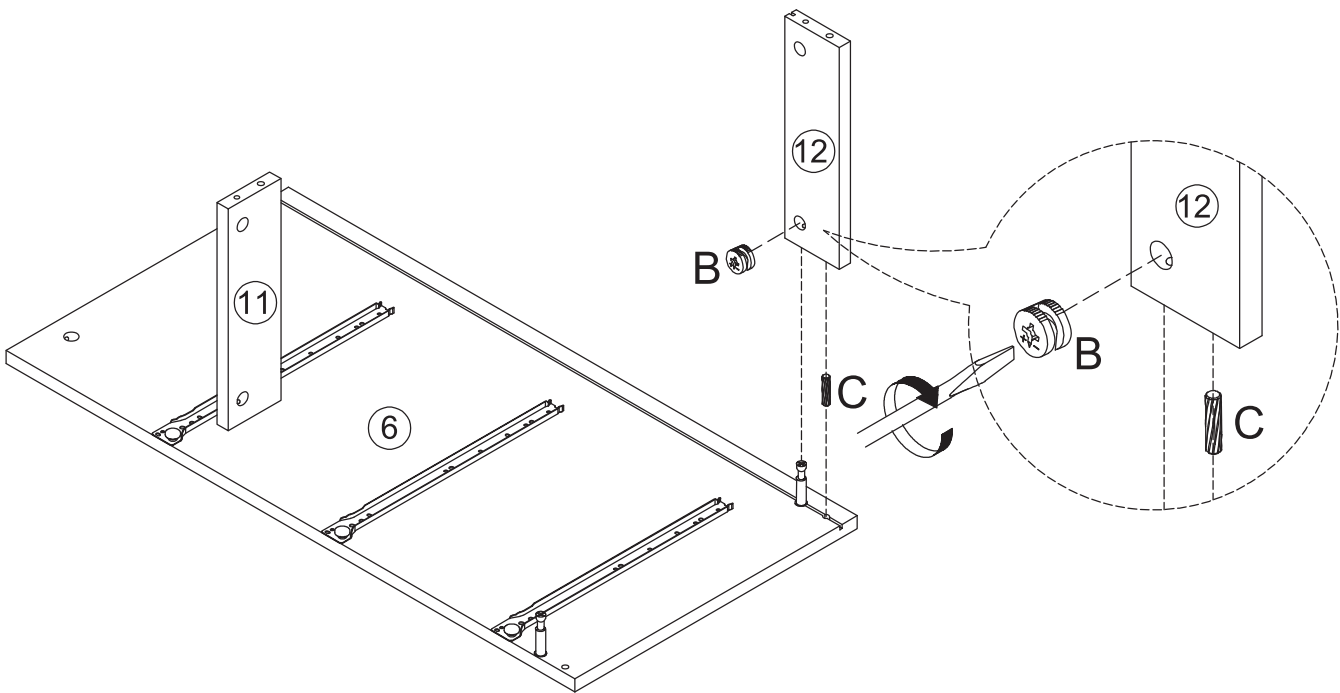

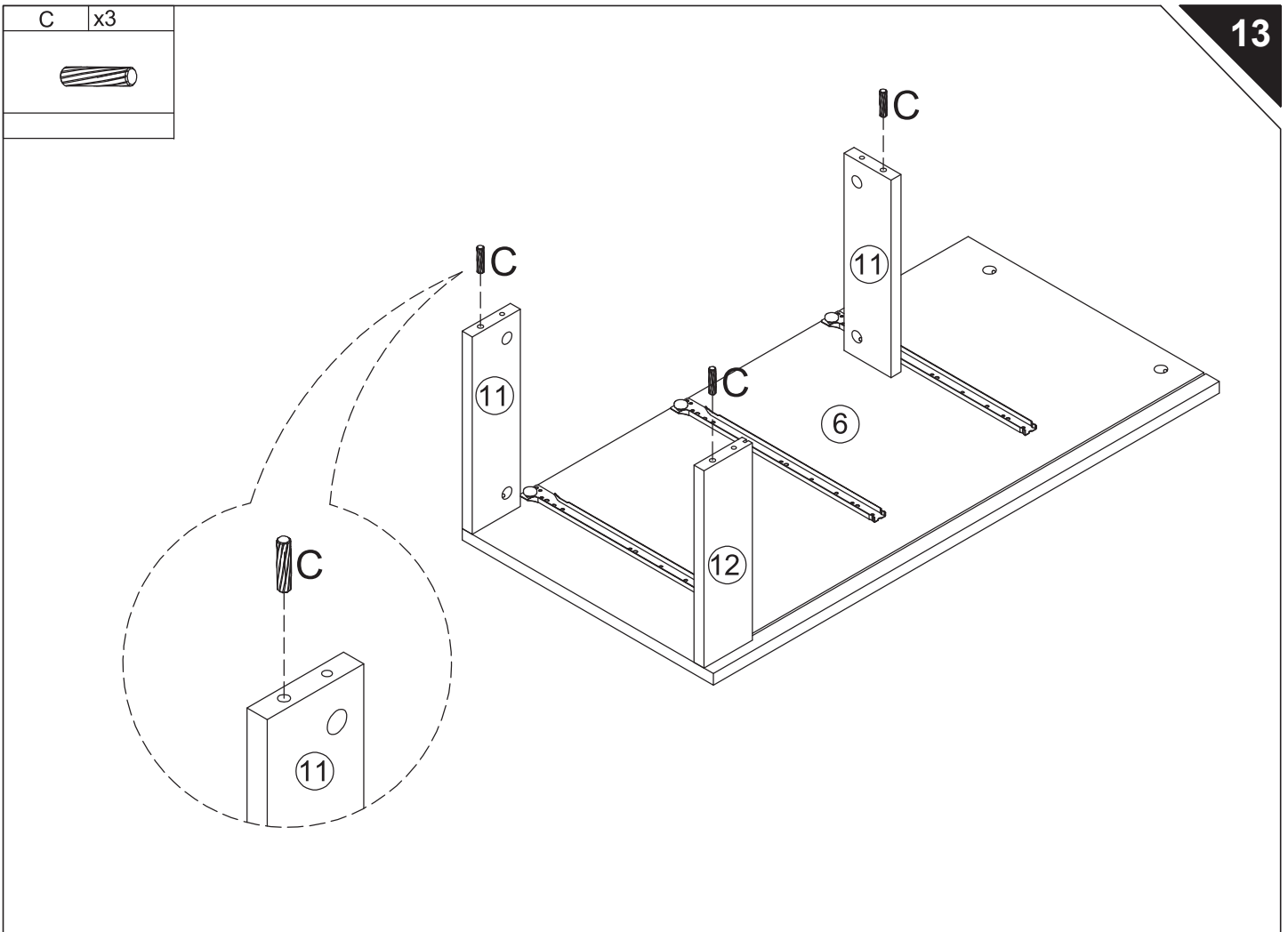
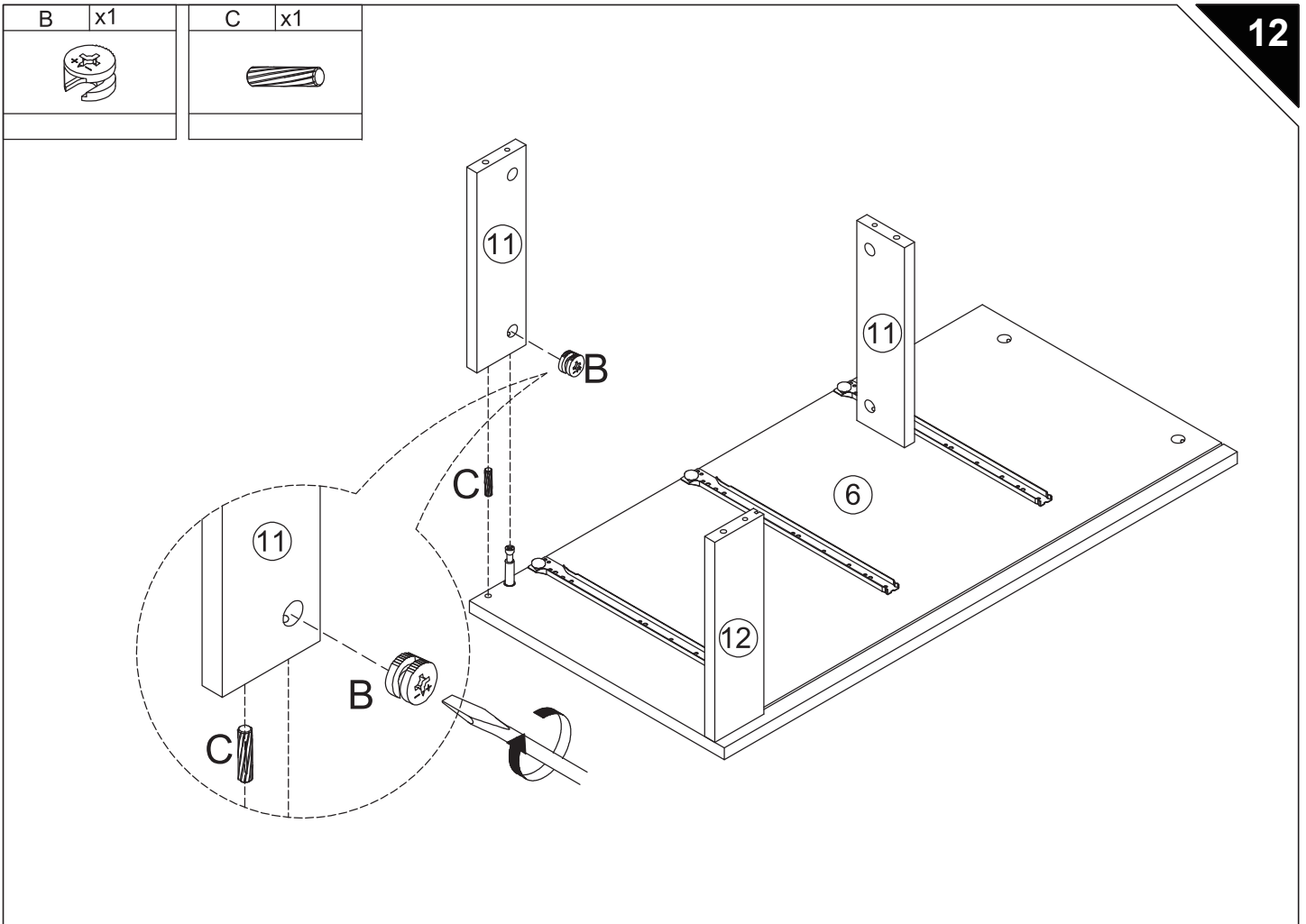
B	x1	C	x1
			





CL	x1	CR	x3	E	x12
					
L350mm		L300mm			

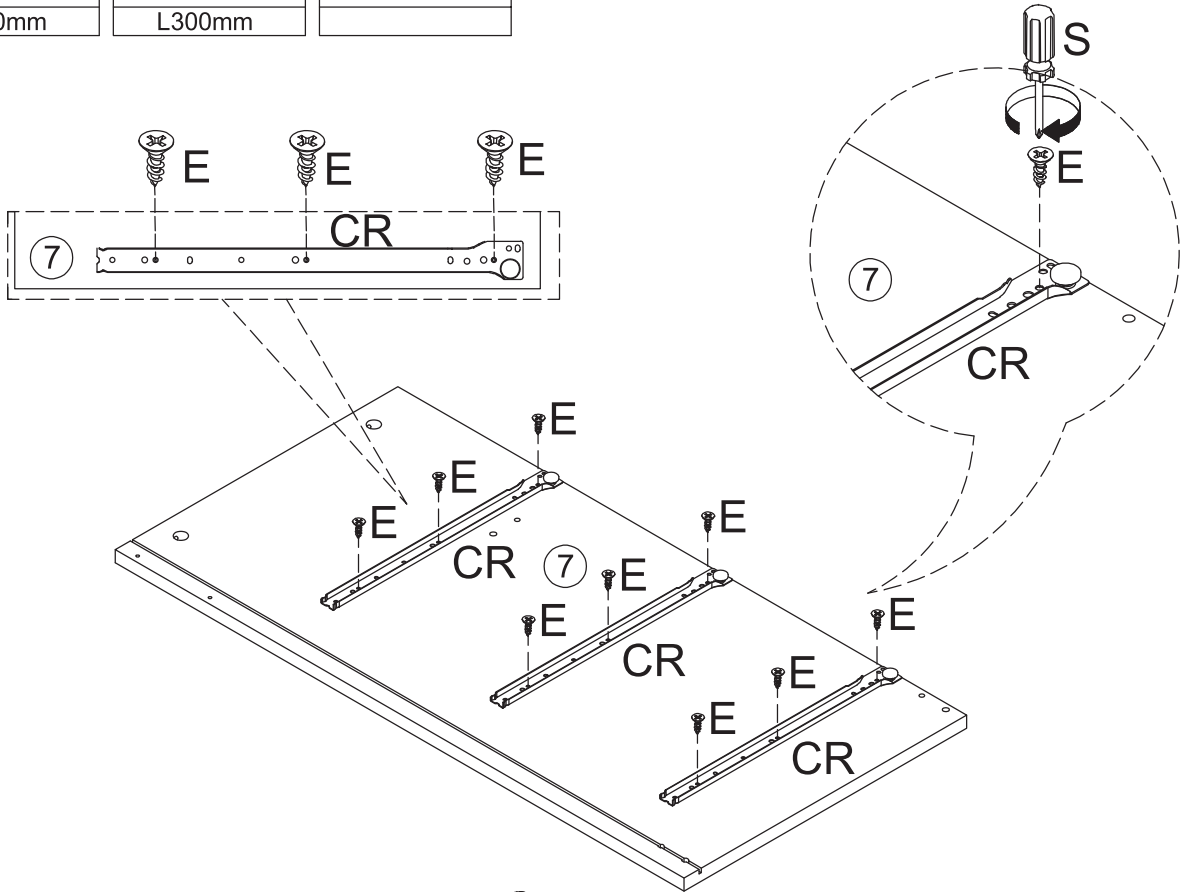

Panel 7 flipped to the other side

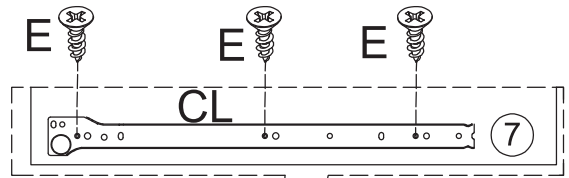

Attention, First hole

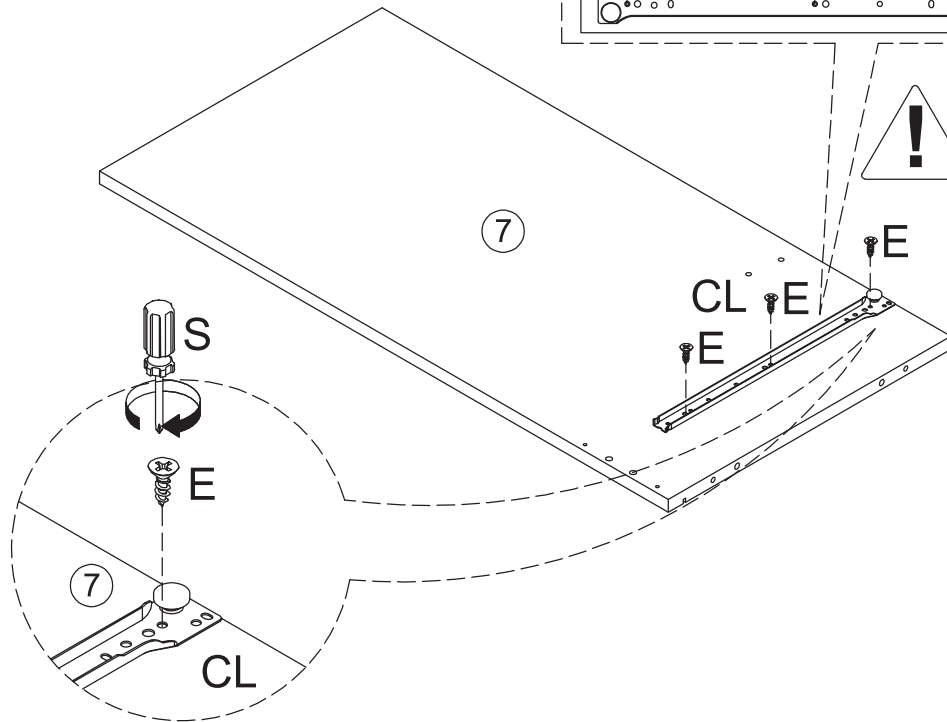

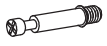

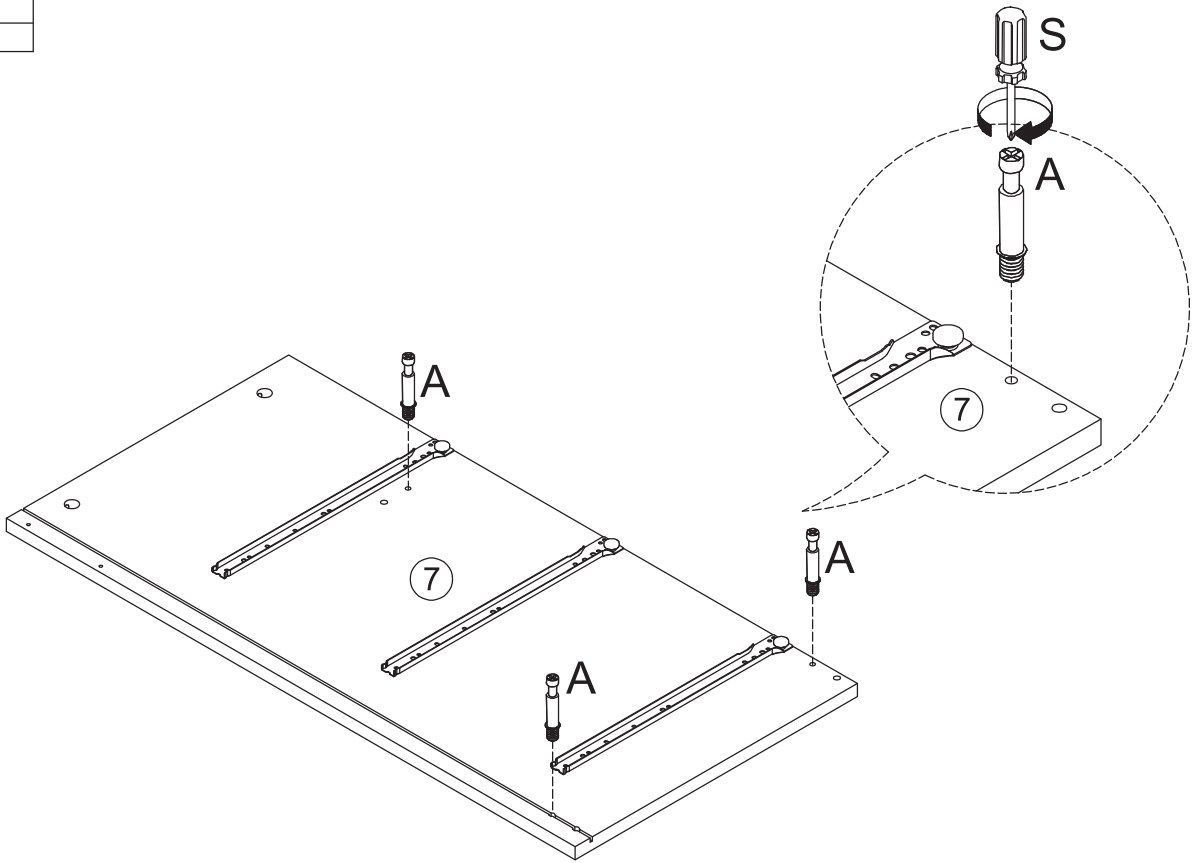
A	x3
	

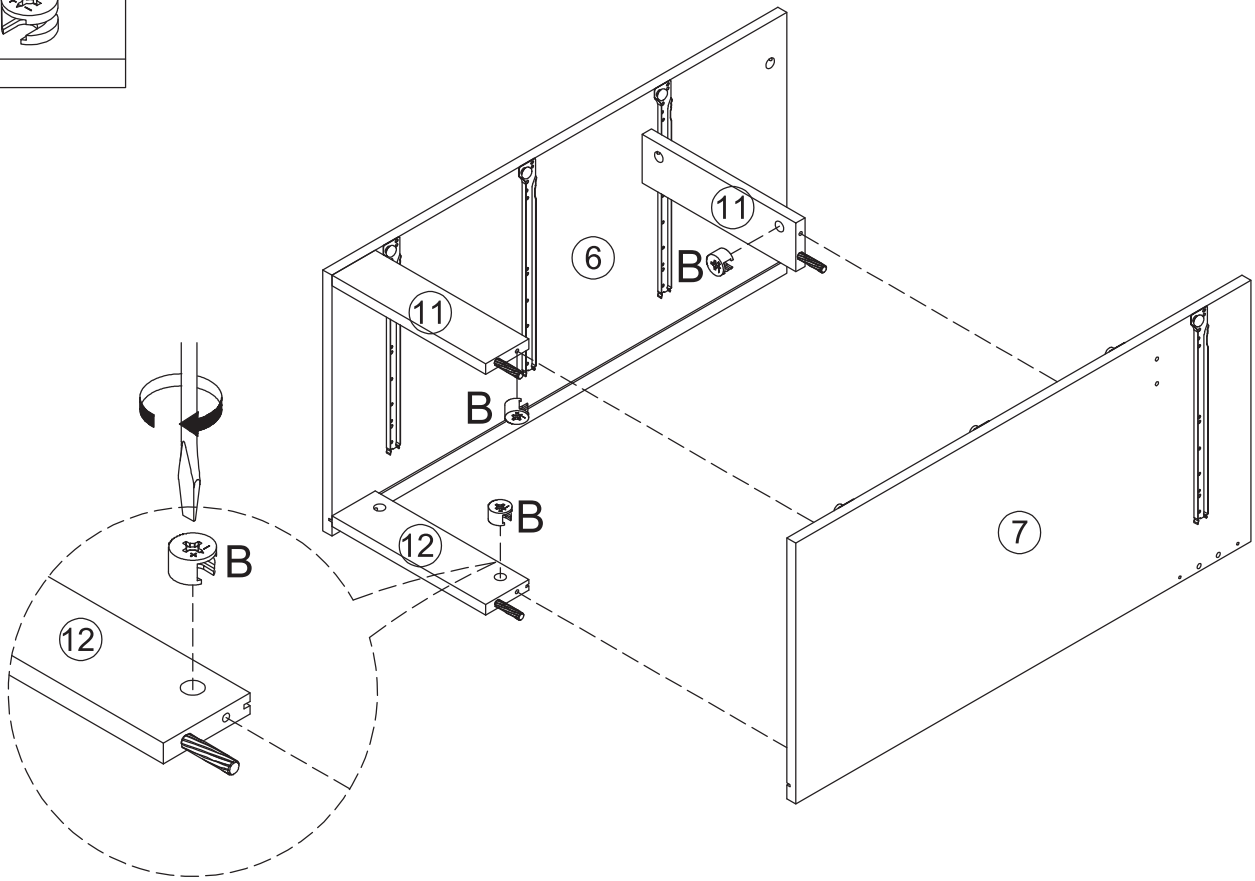

B	x3
	



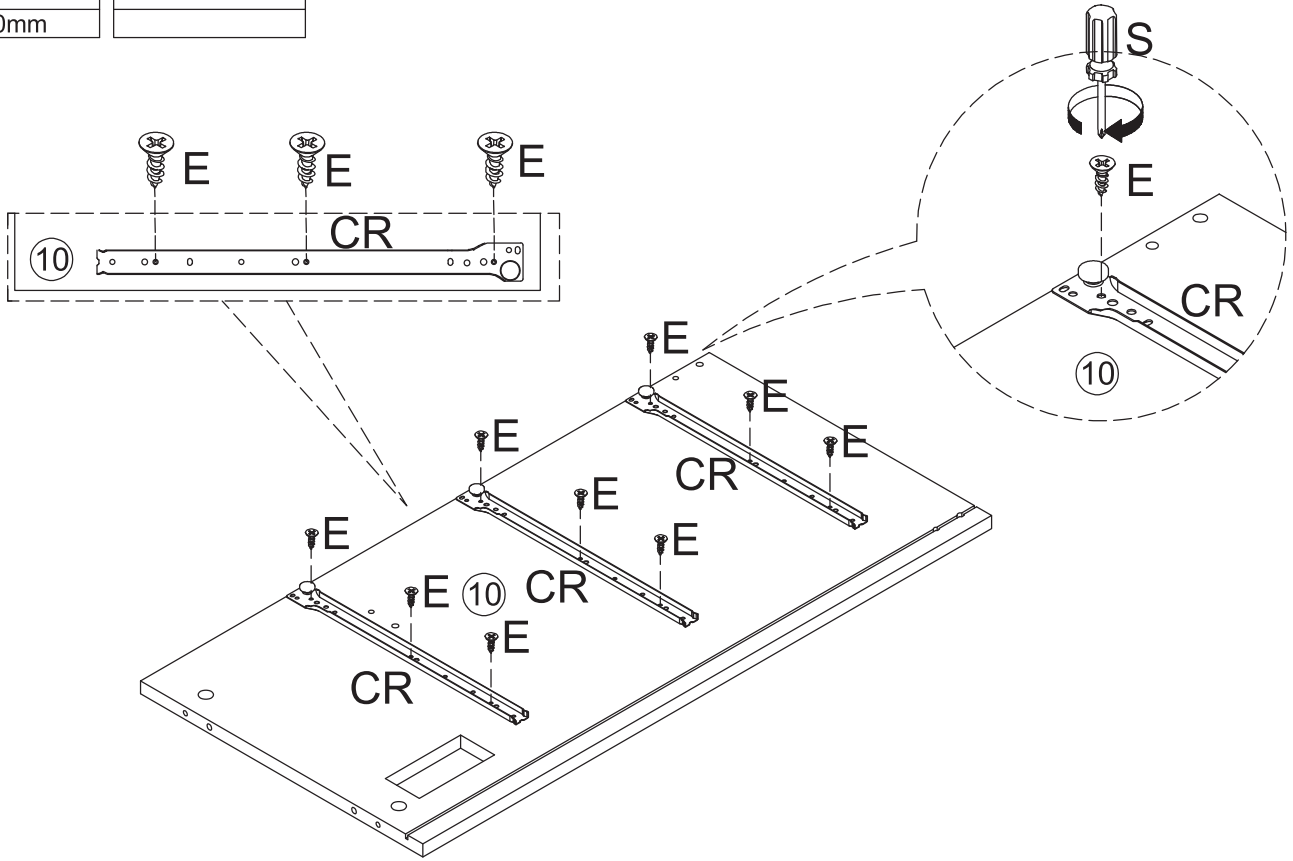

CR	x3	E	x9
			
L300mm			



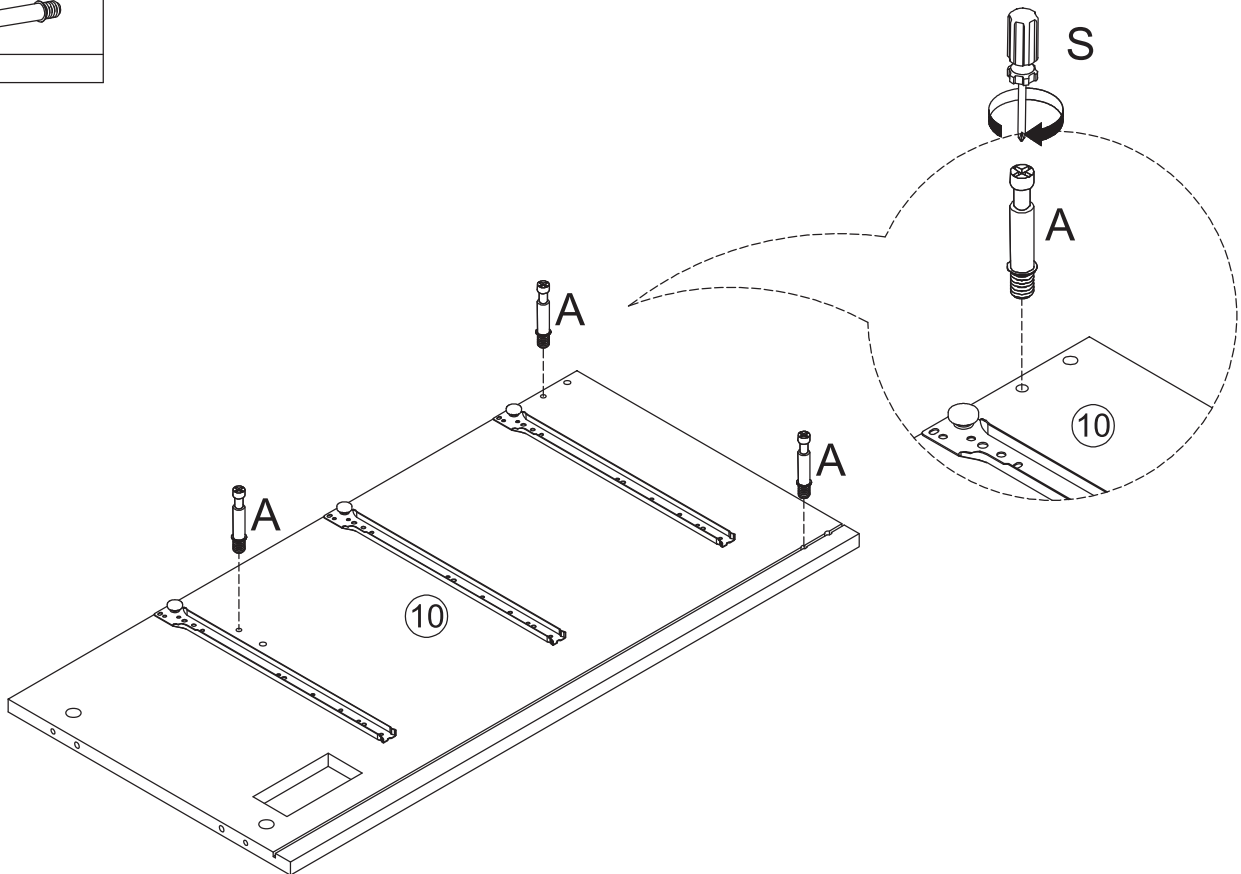

A	x3
	



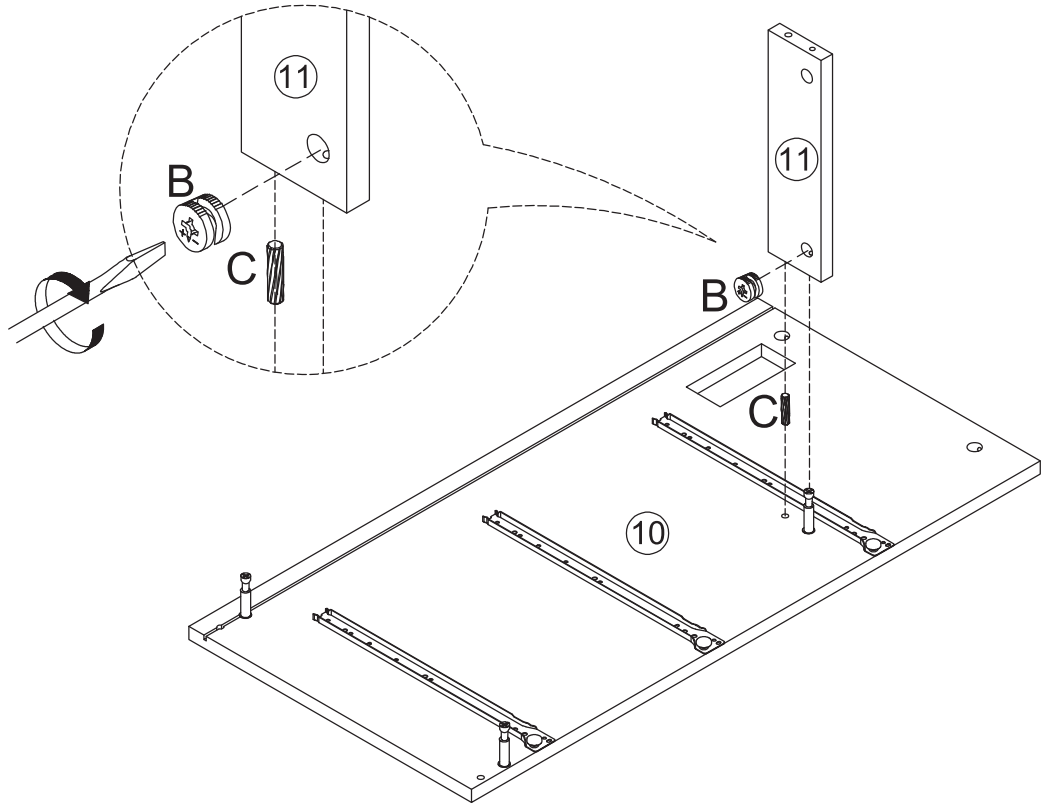

B	x1	C	x1
			



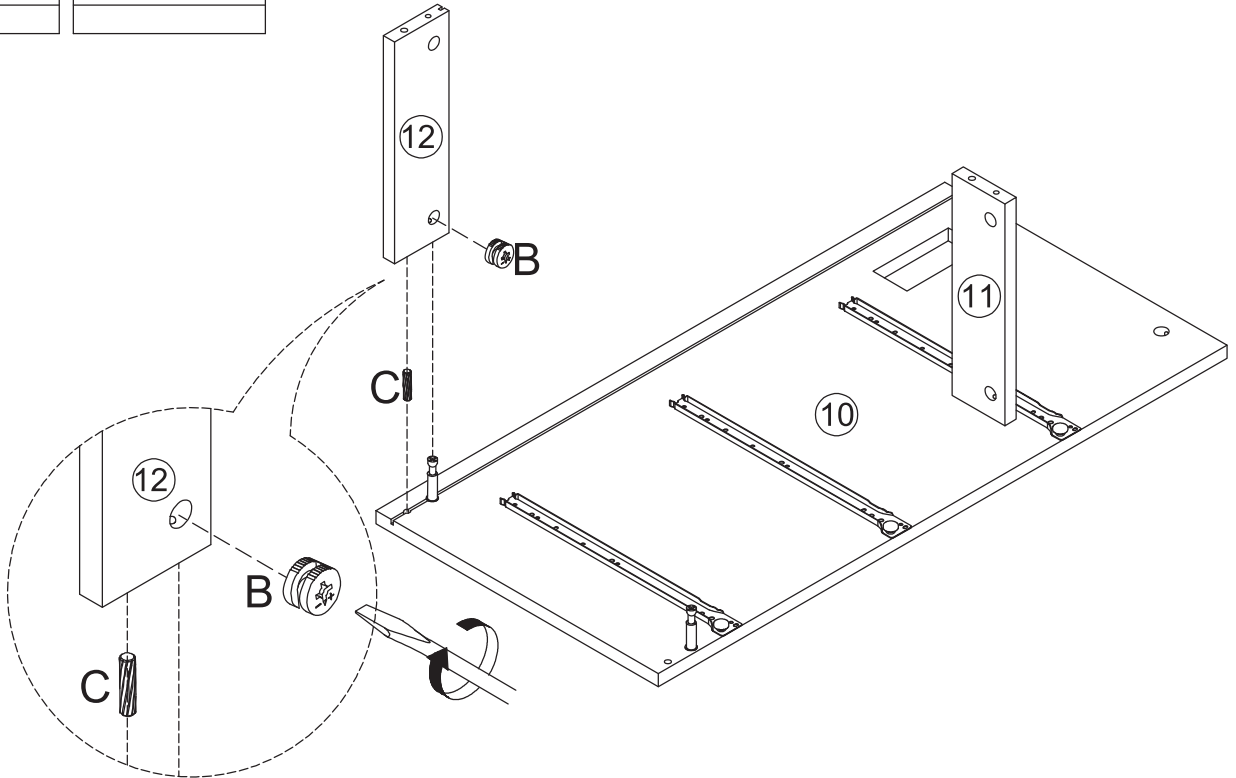

B	x1	C	x1
			



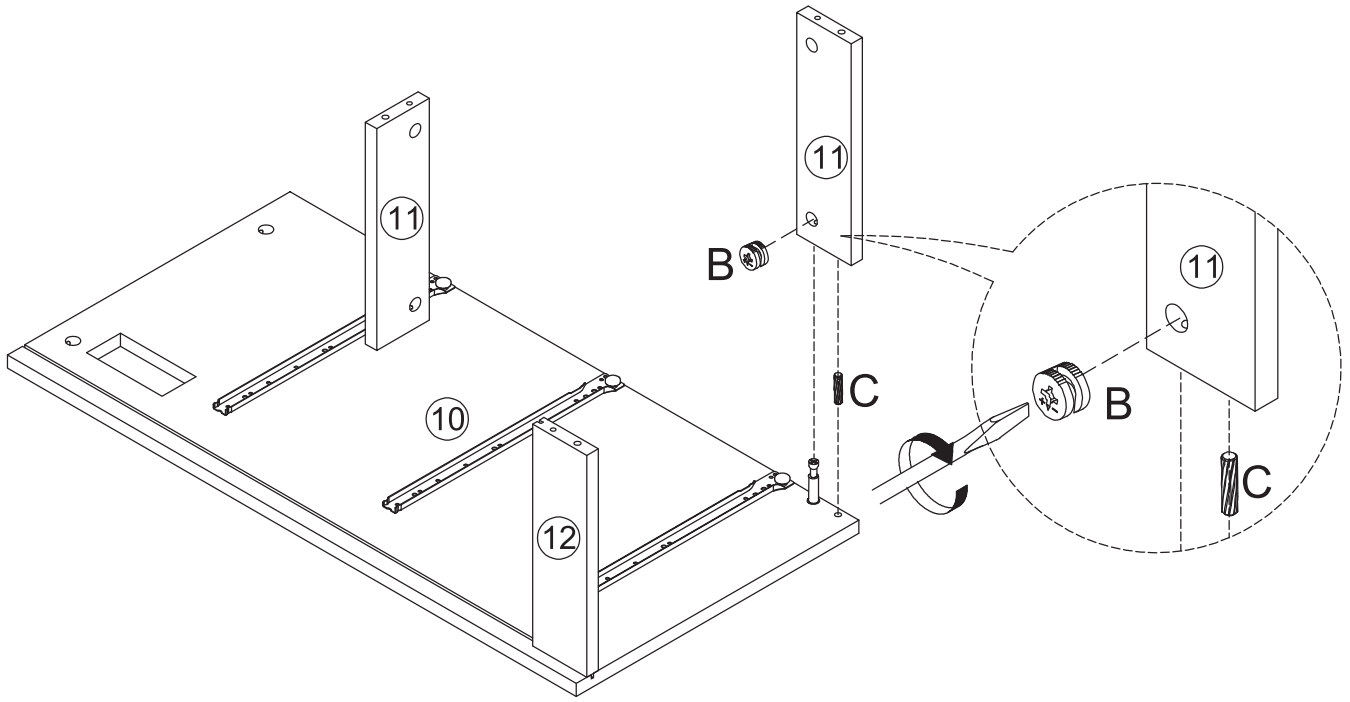

B	x1	C	x1
			

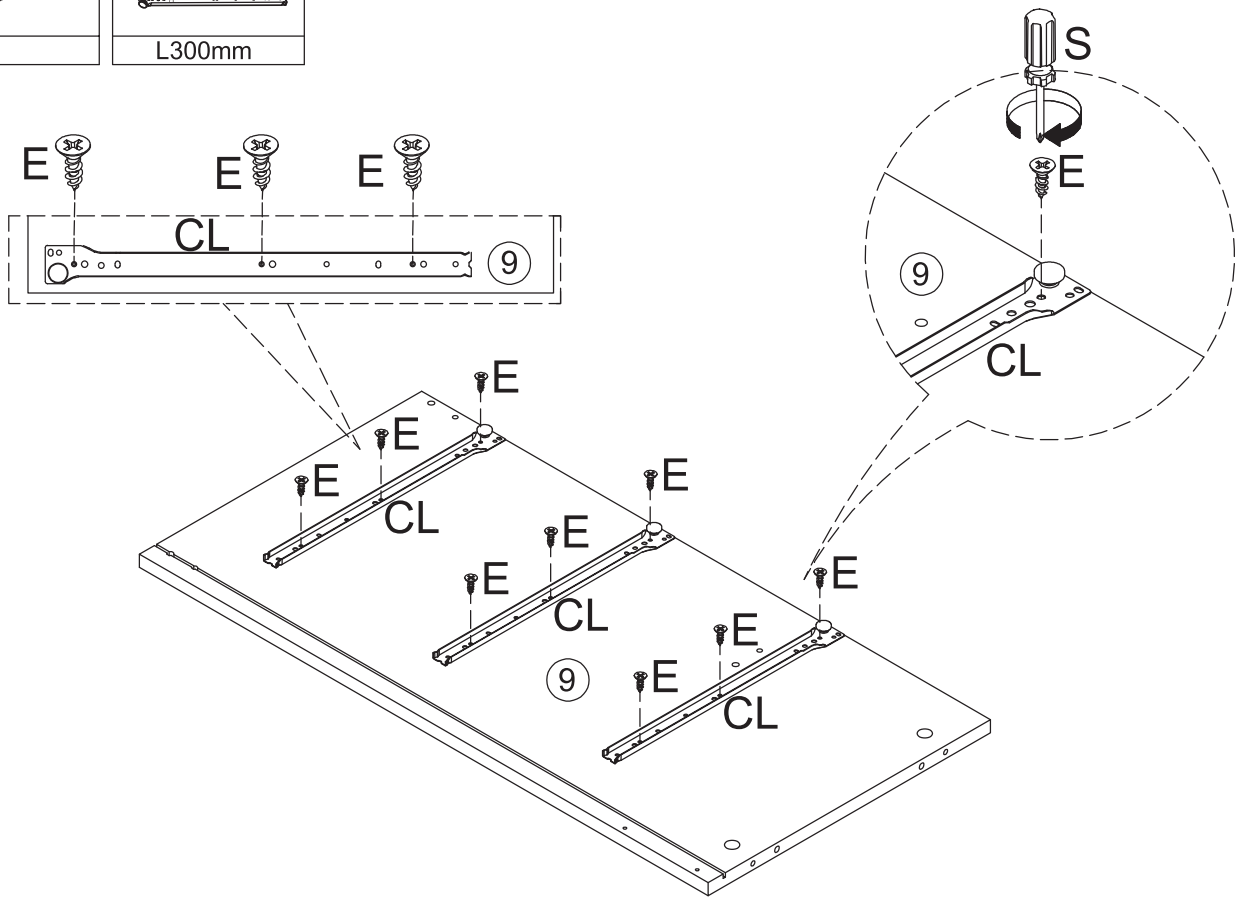

E	x9	CL	x3
			
		L300mm	



E	x3	CR	x1
			
		L350mm	

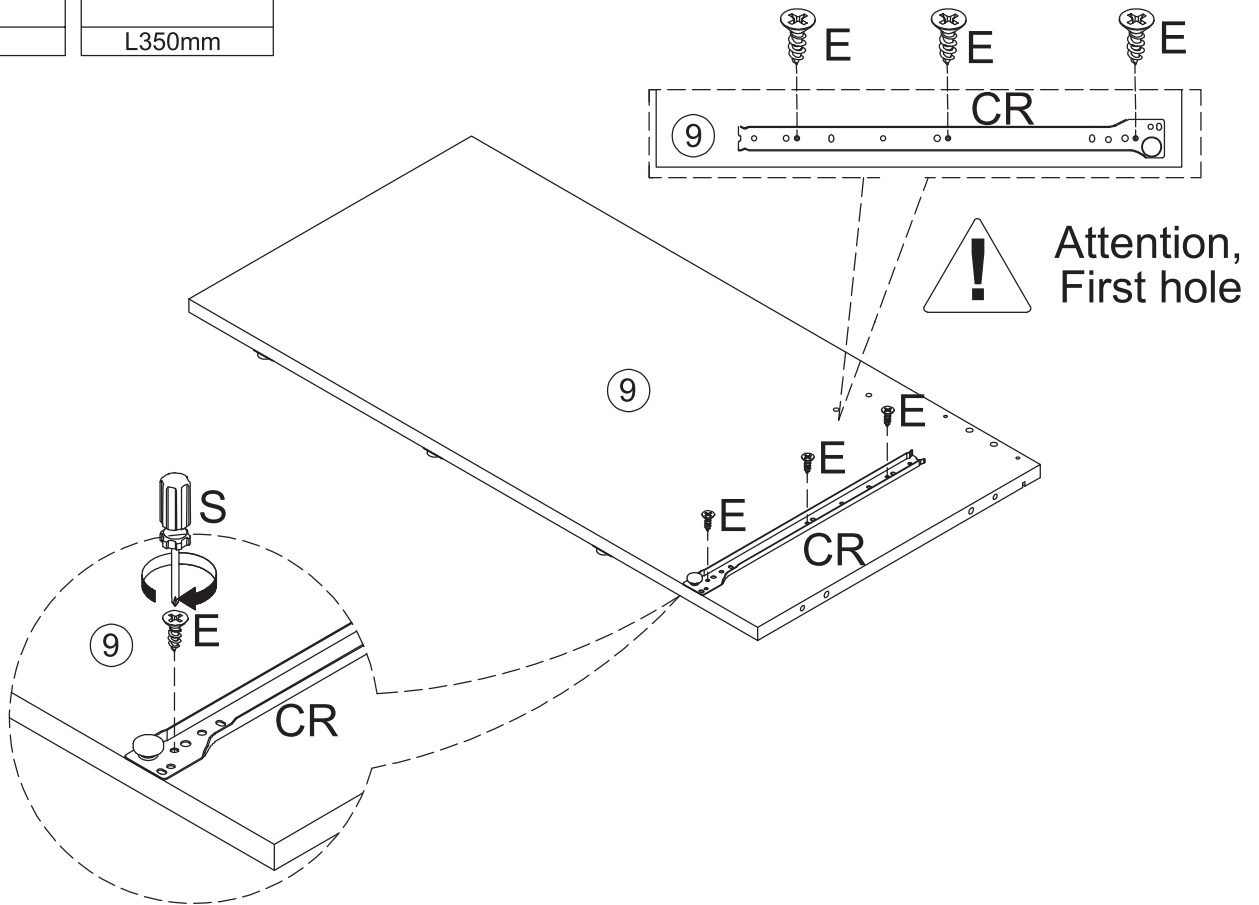

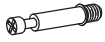
A	x3
	

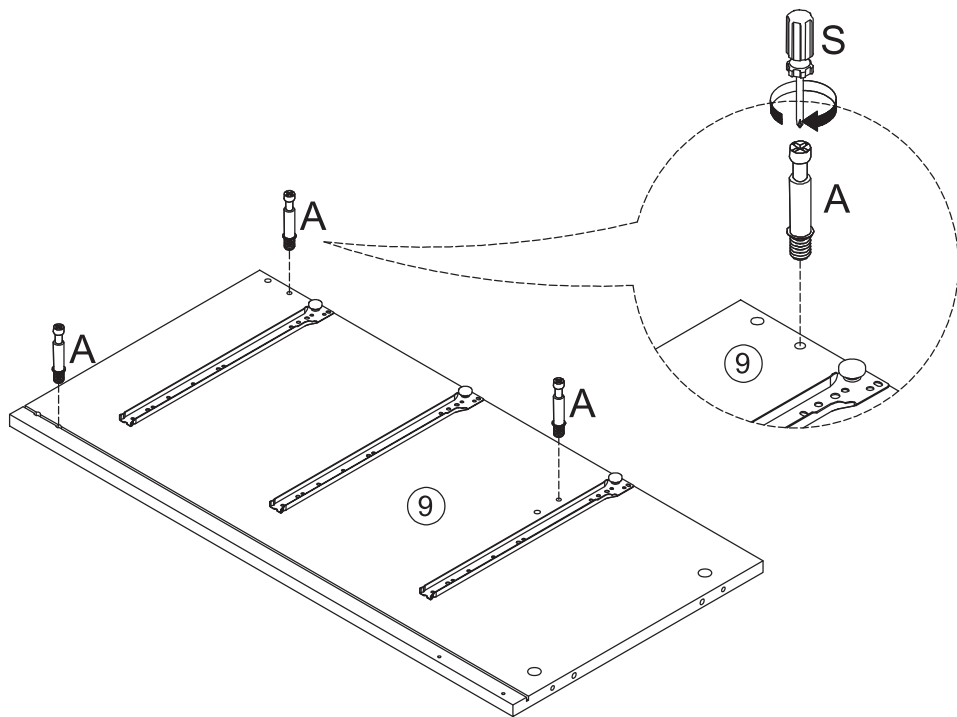

C	x3
	

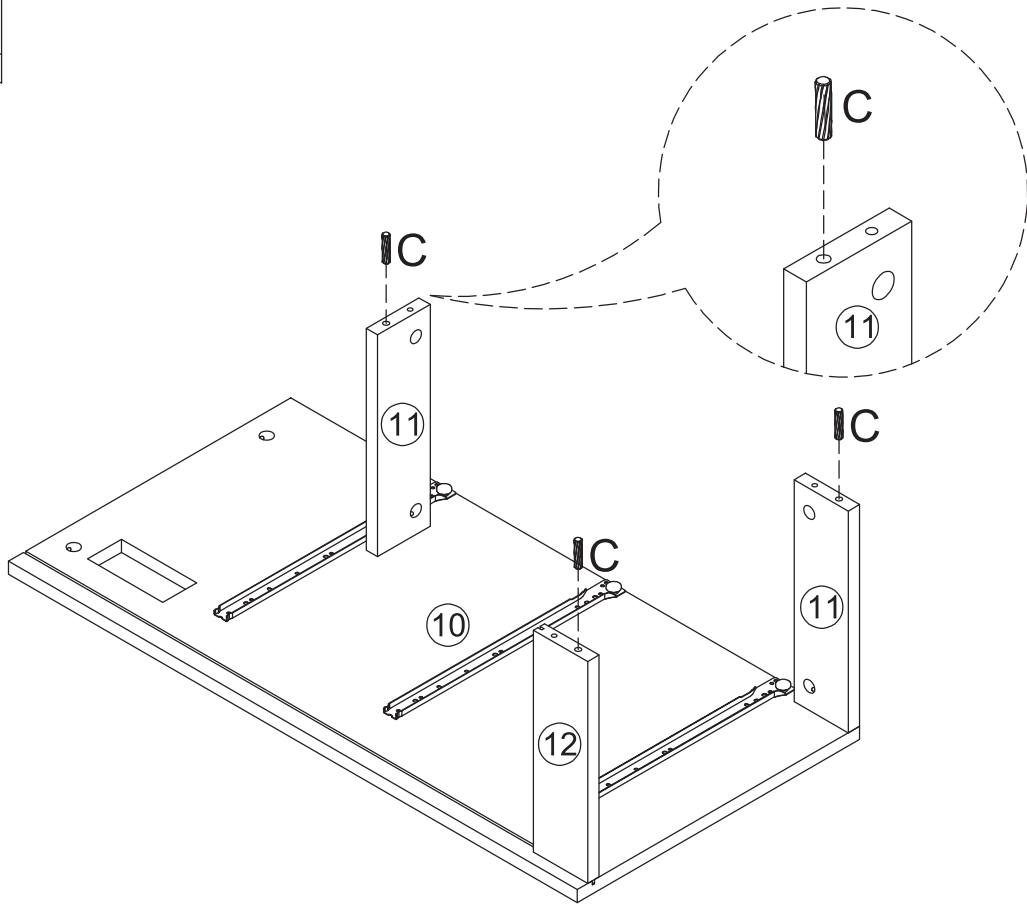

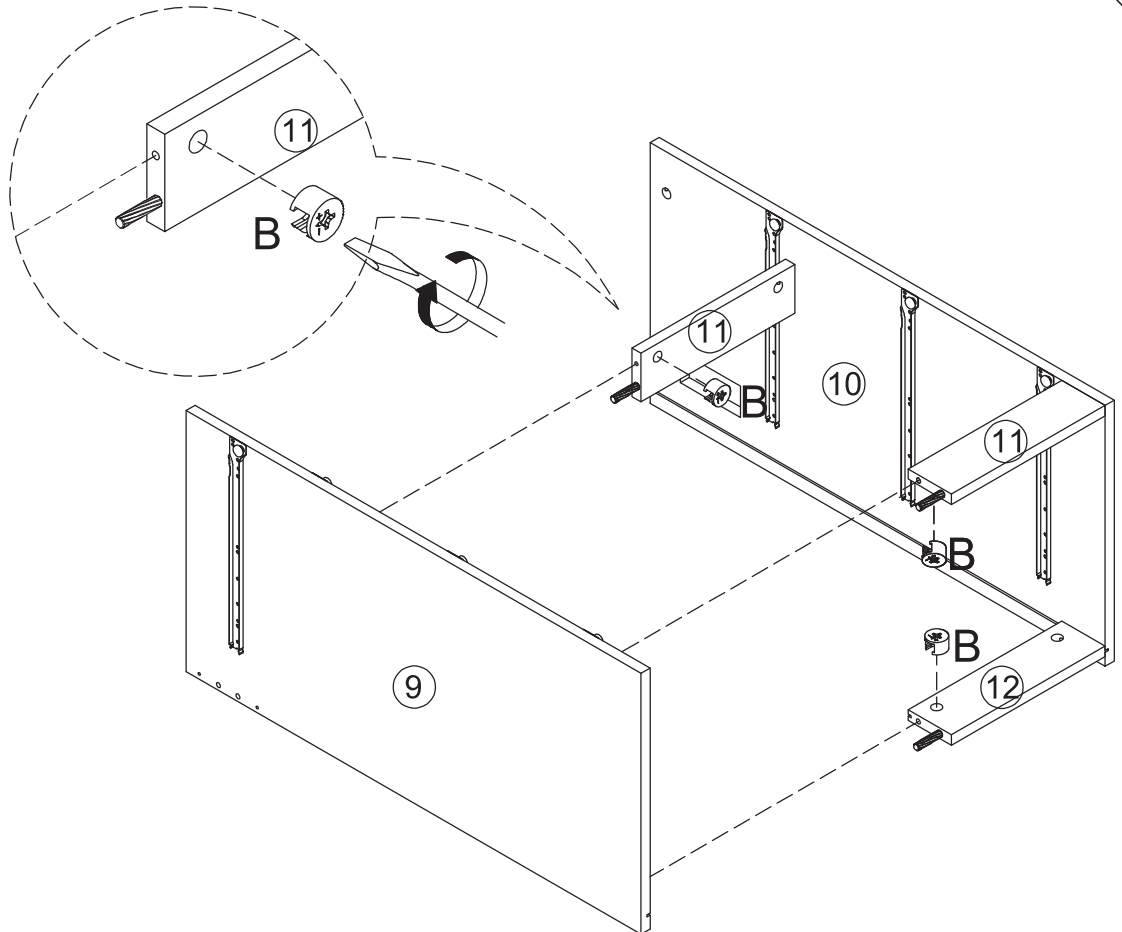

B	x3
	

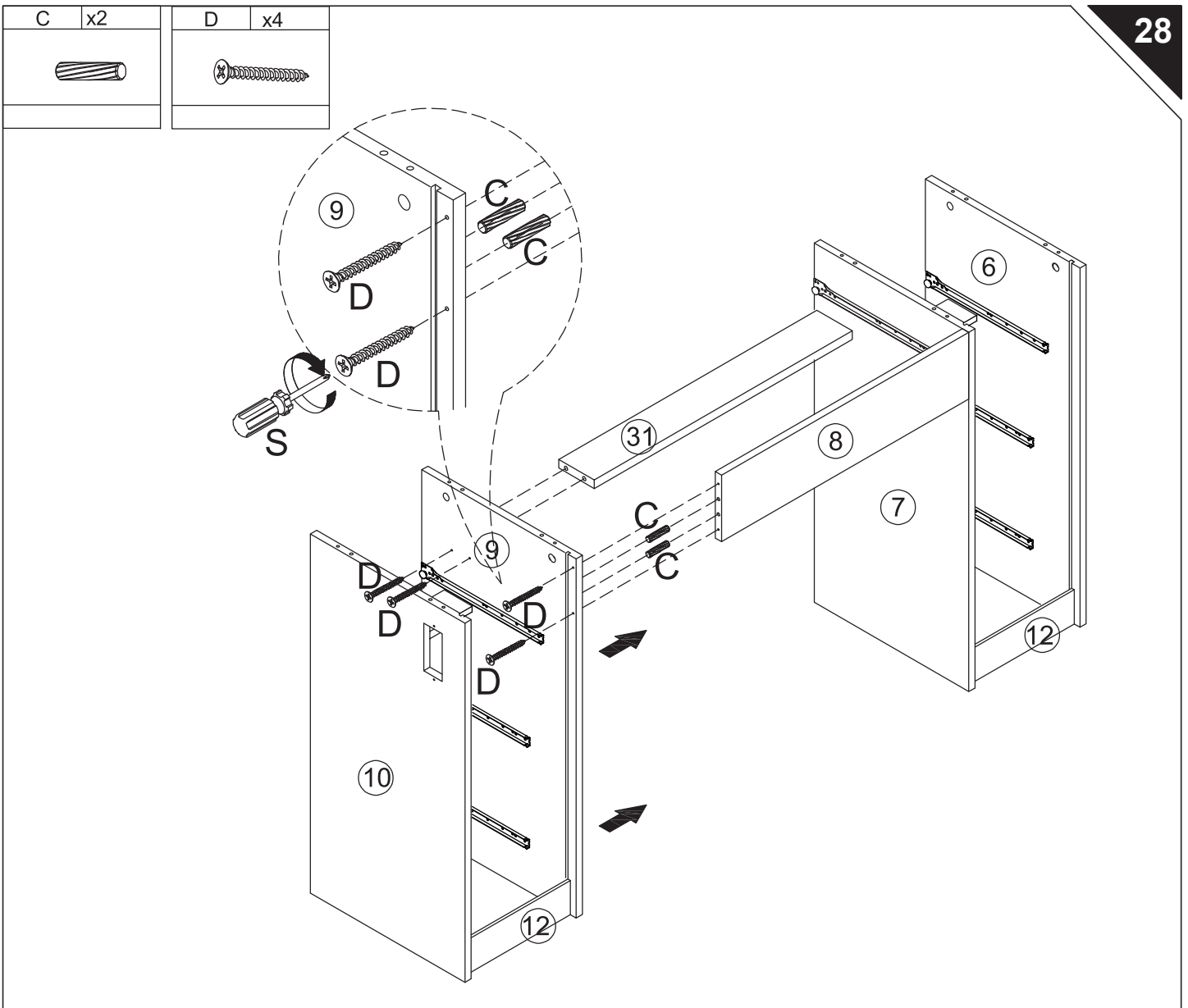
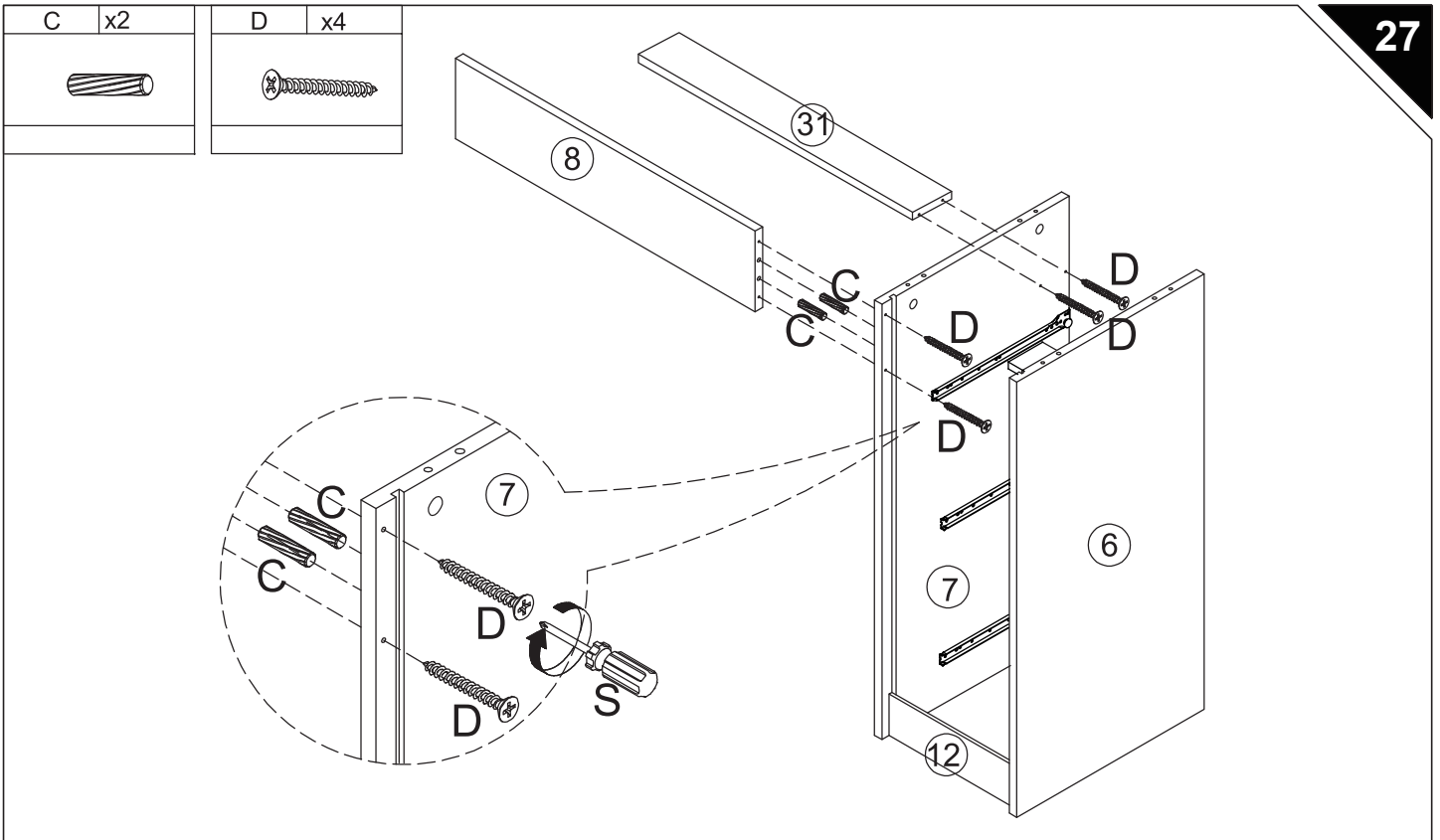

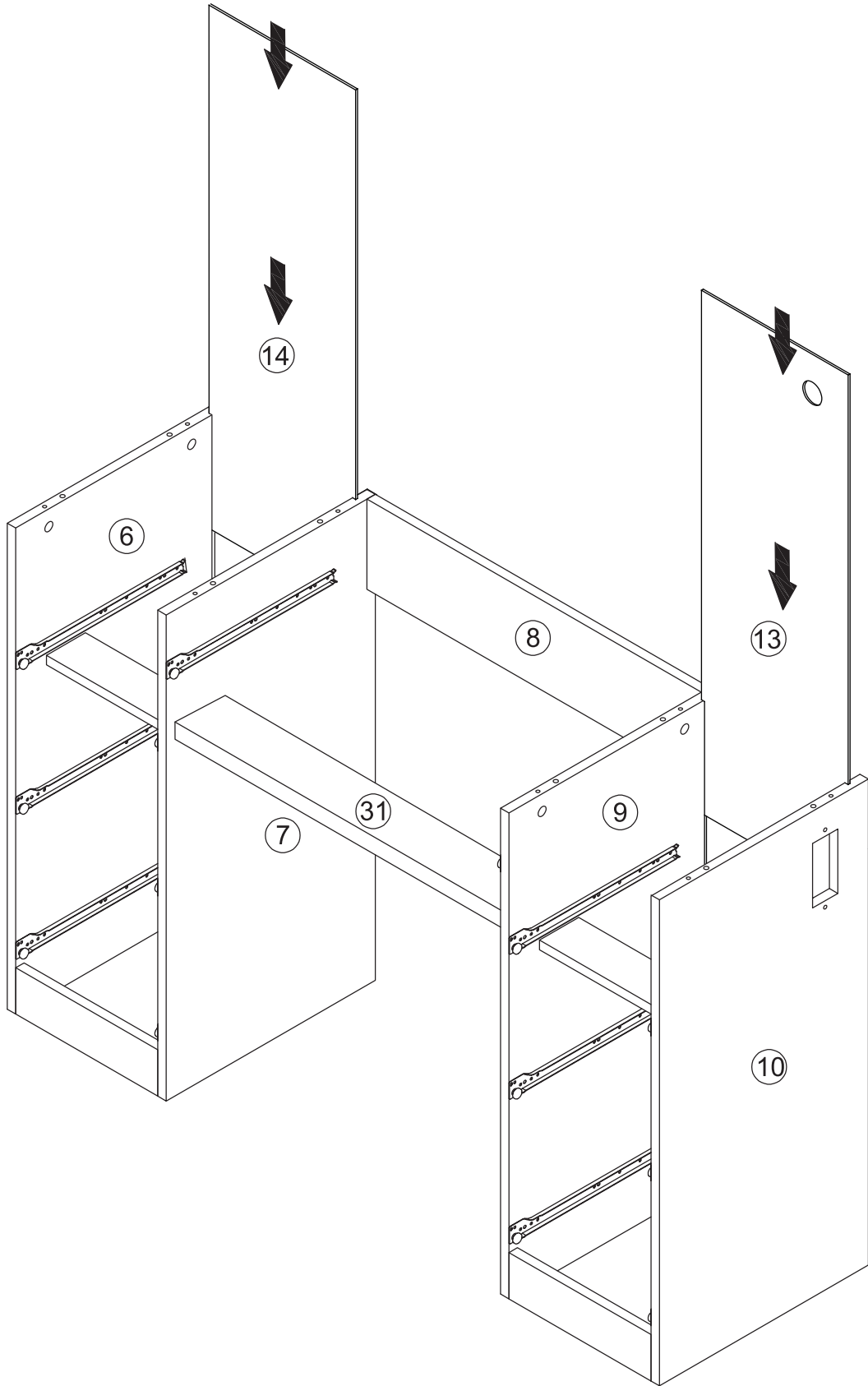



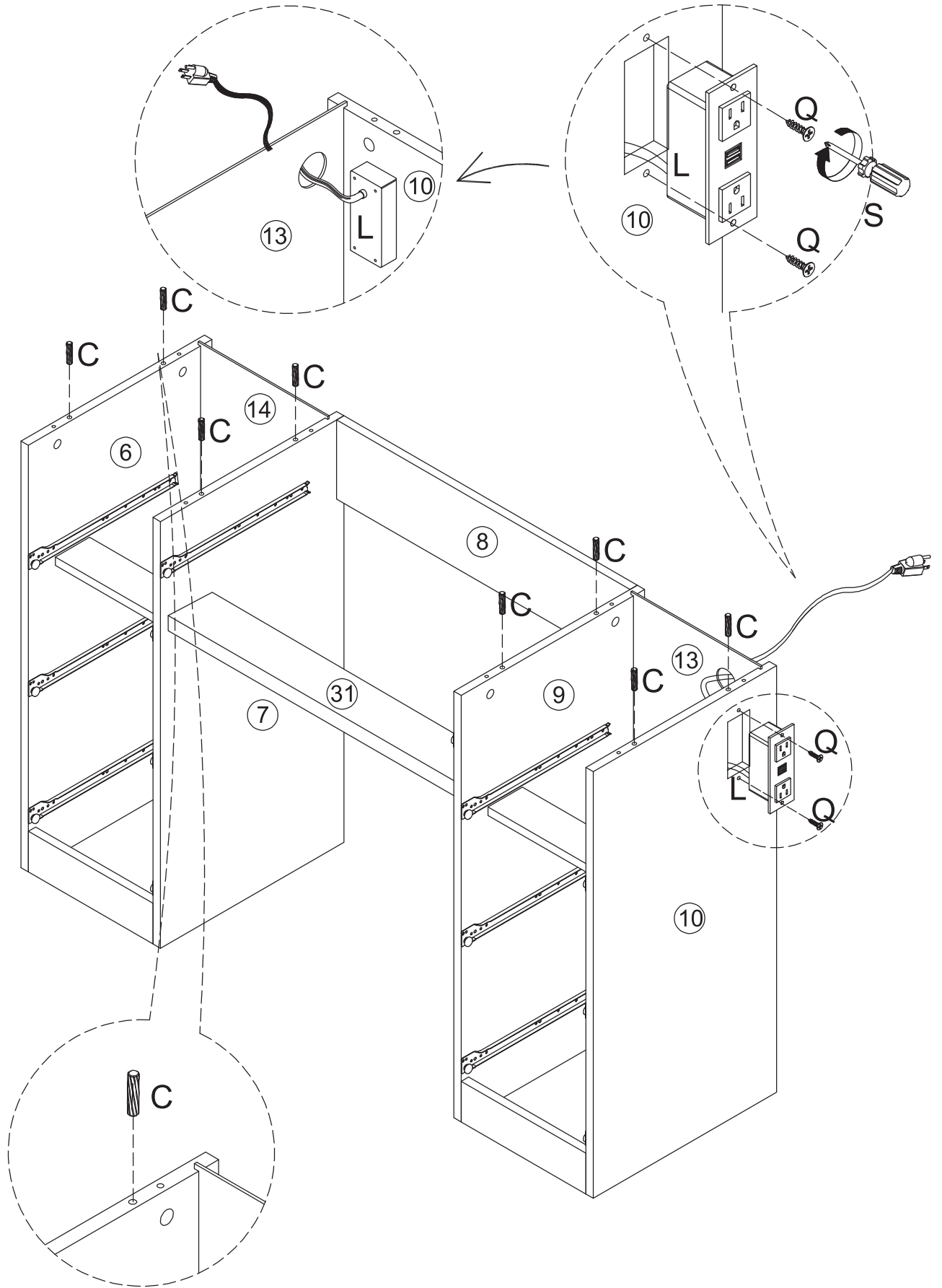

C	x8	L	x1	Q	x2
					

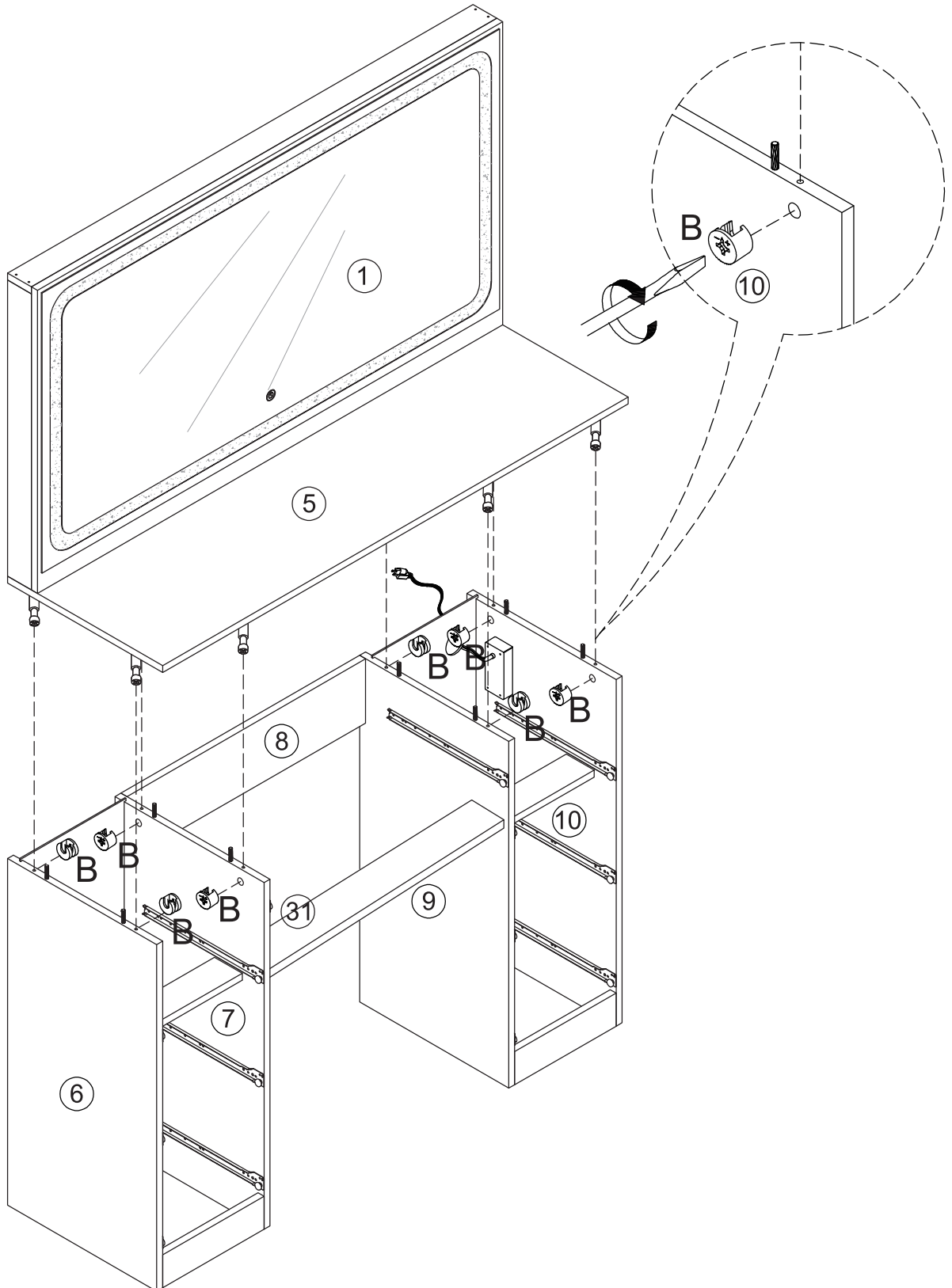



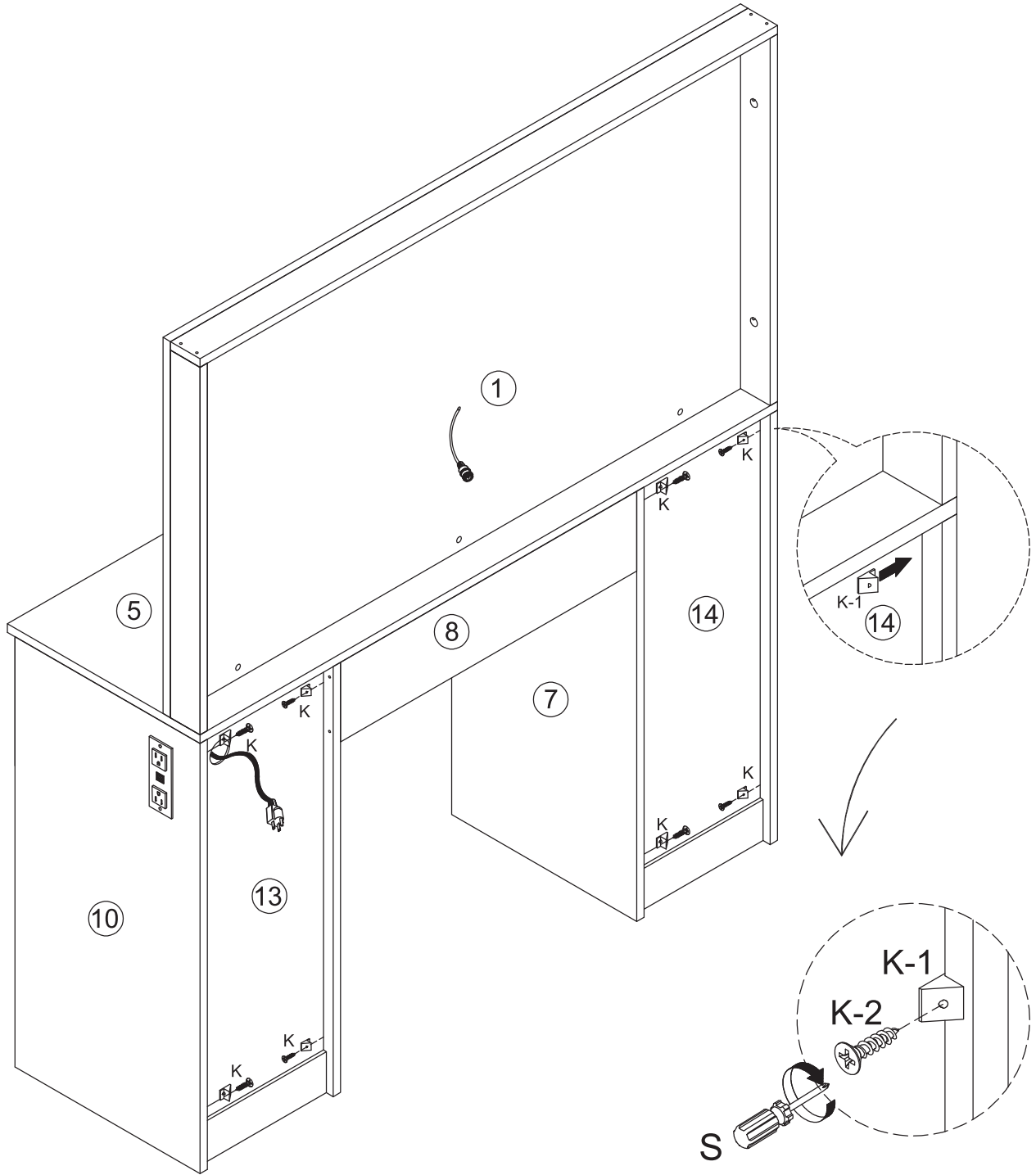

K	x8
K-1	K-2



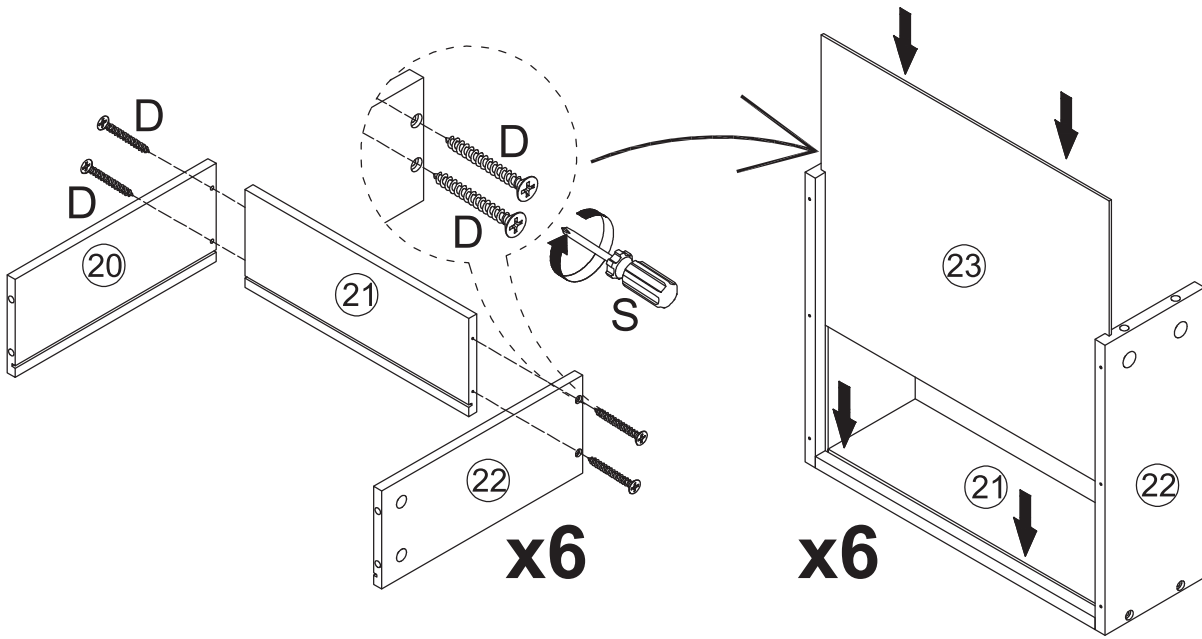

D	x24
	





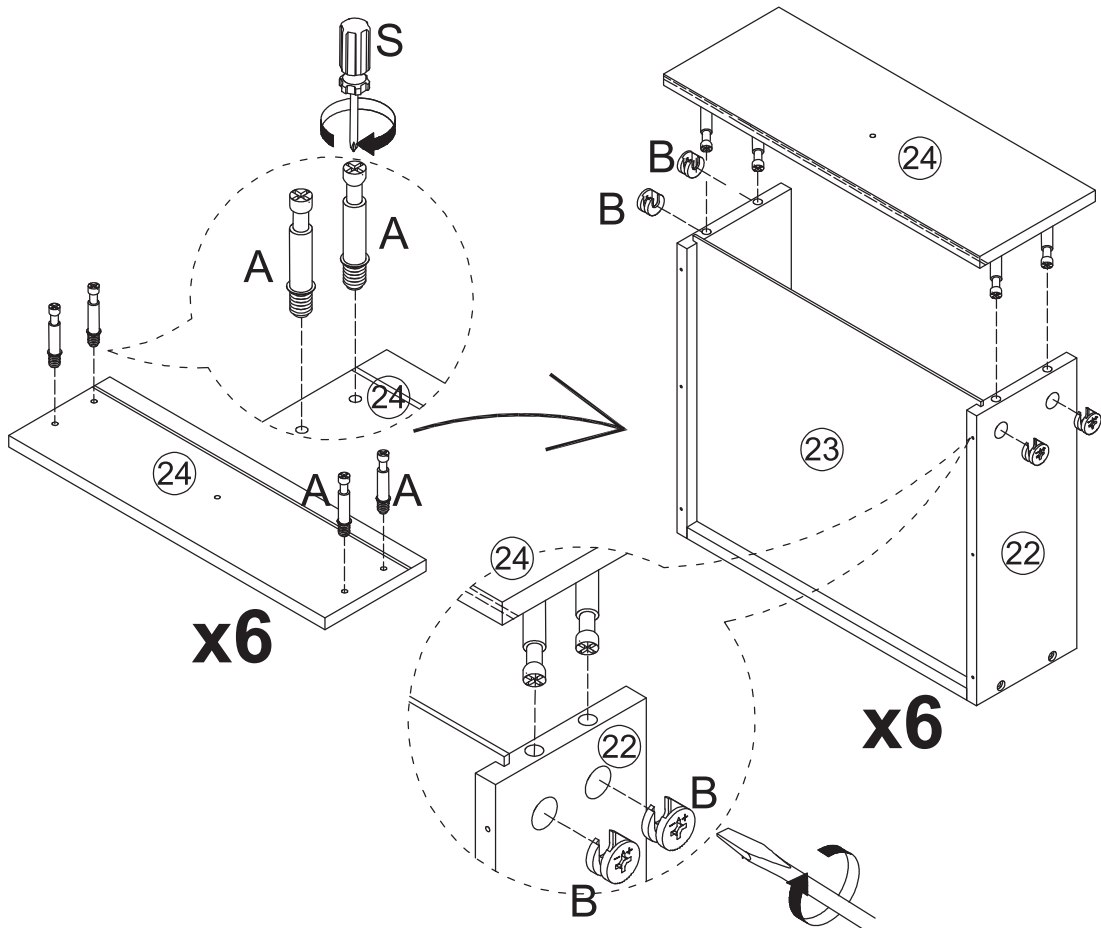

A	x24
	

B	x24
	

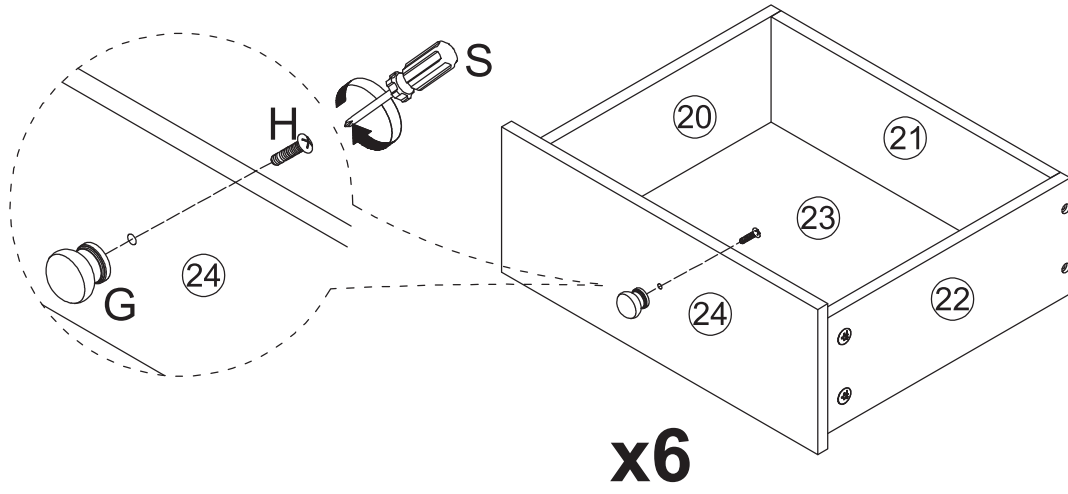



G	x6	H	x6
			



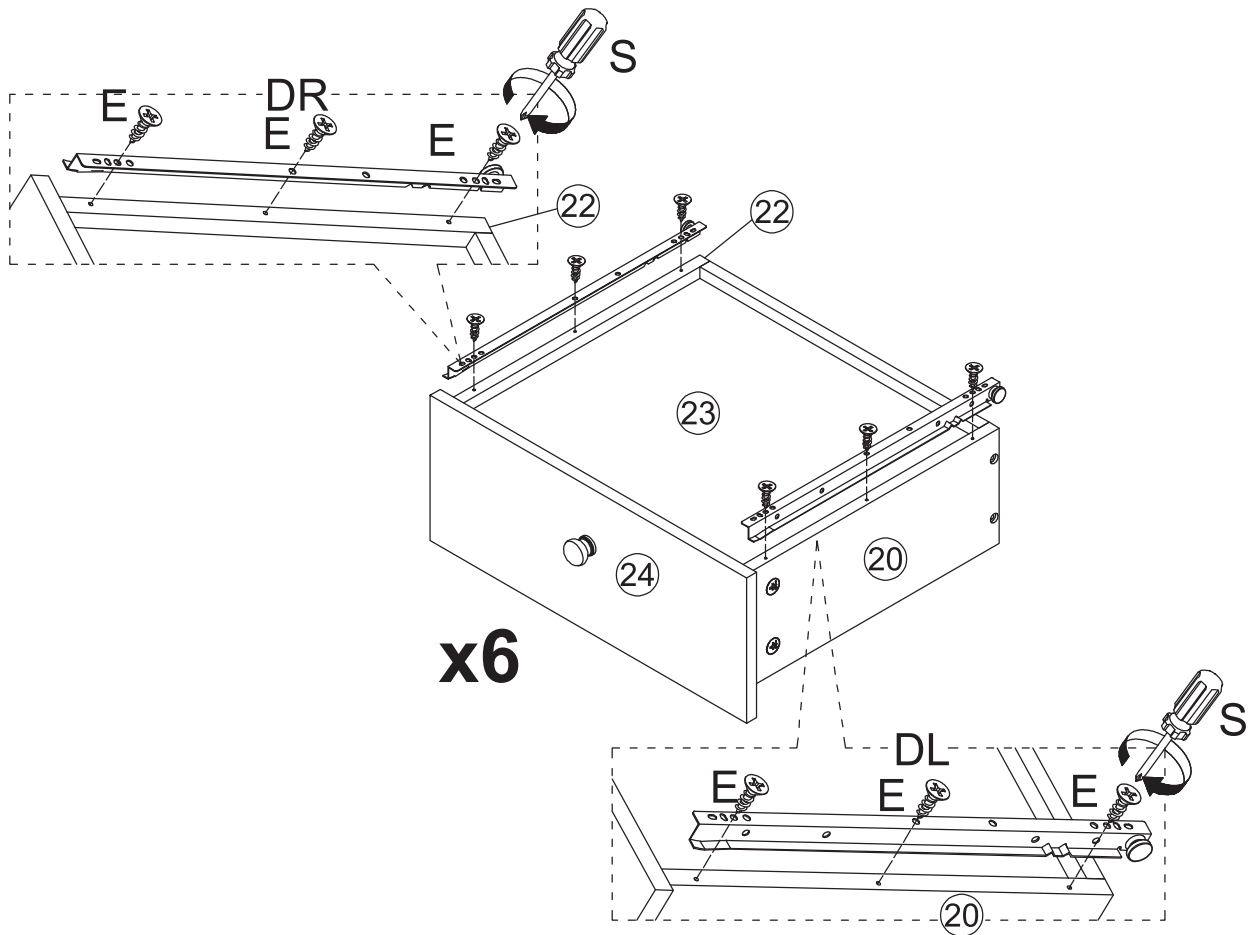

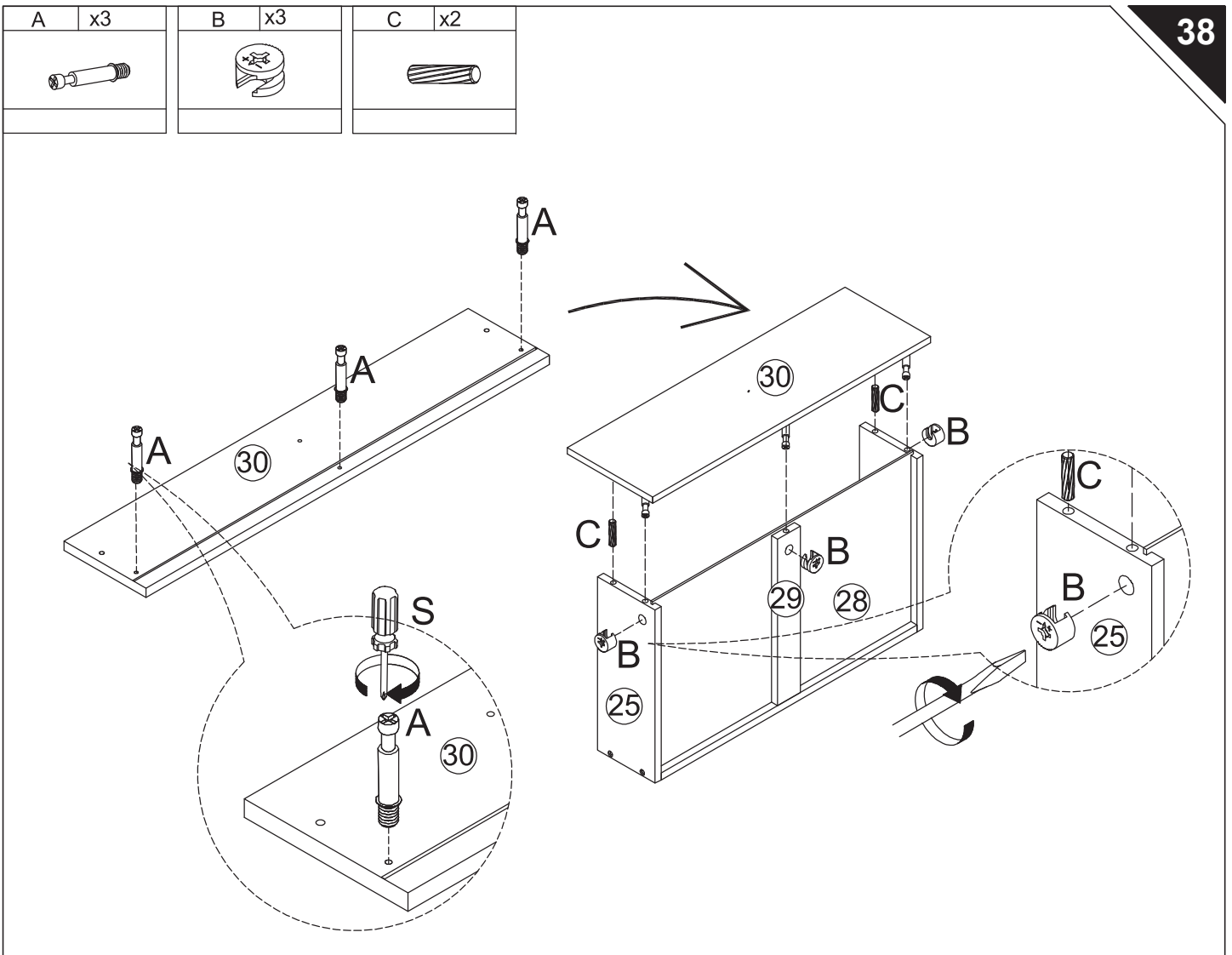
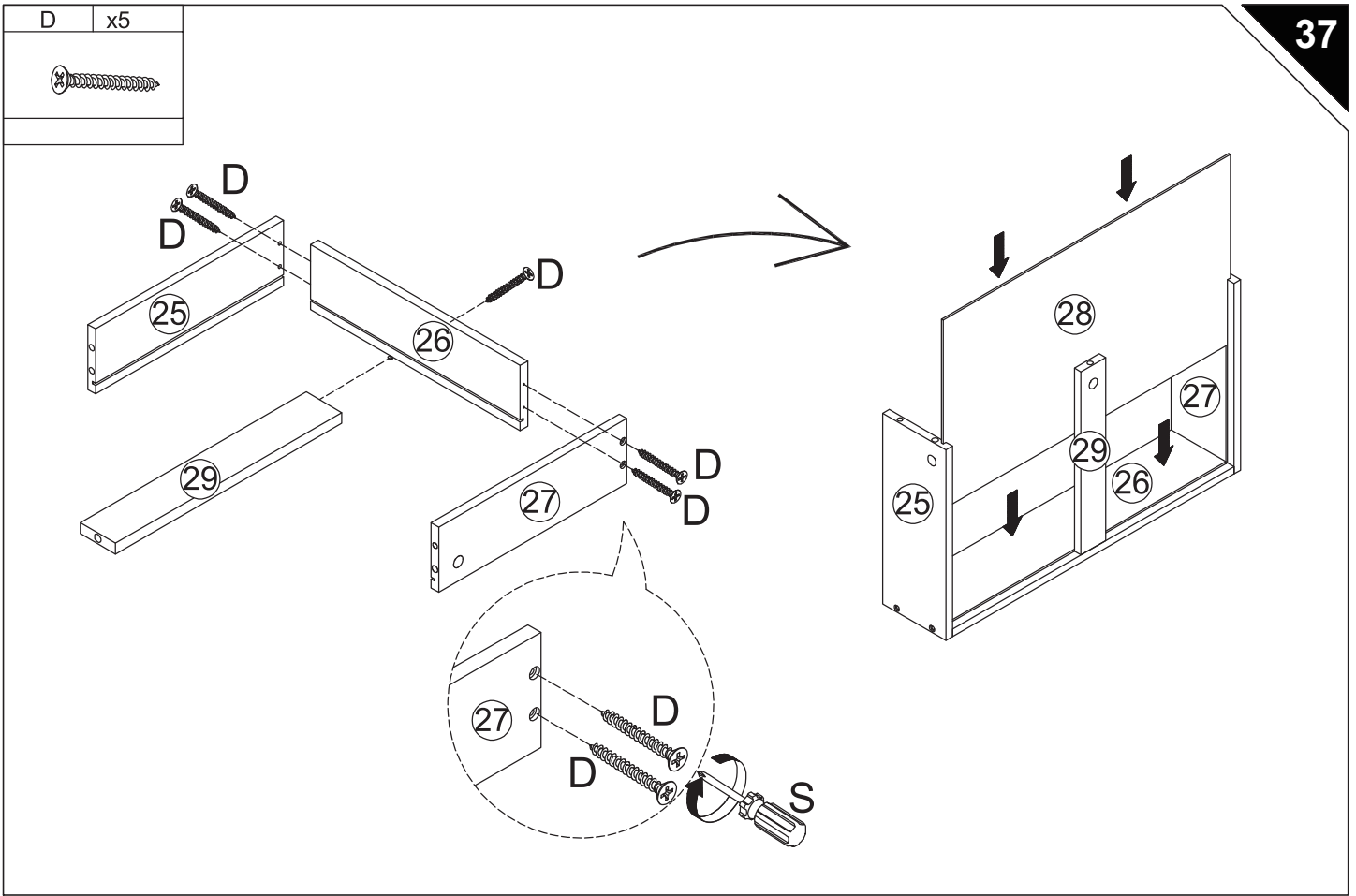

E	x36	DL	x6	DR	x6
					
		L300mm		L300mm	



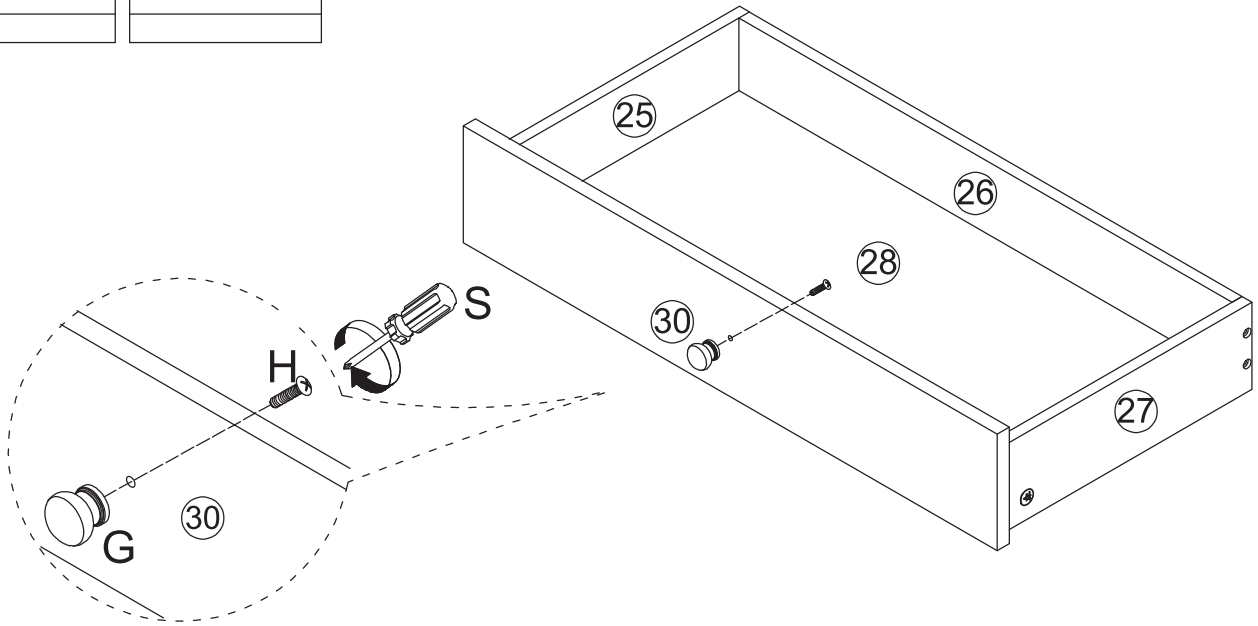



G	x1	H	x1
			



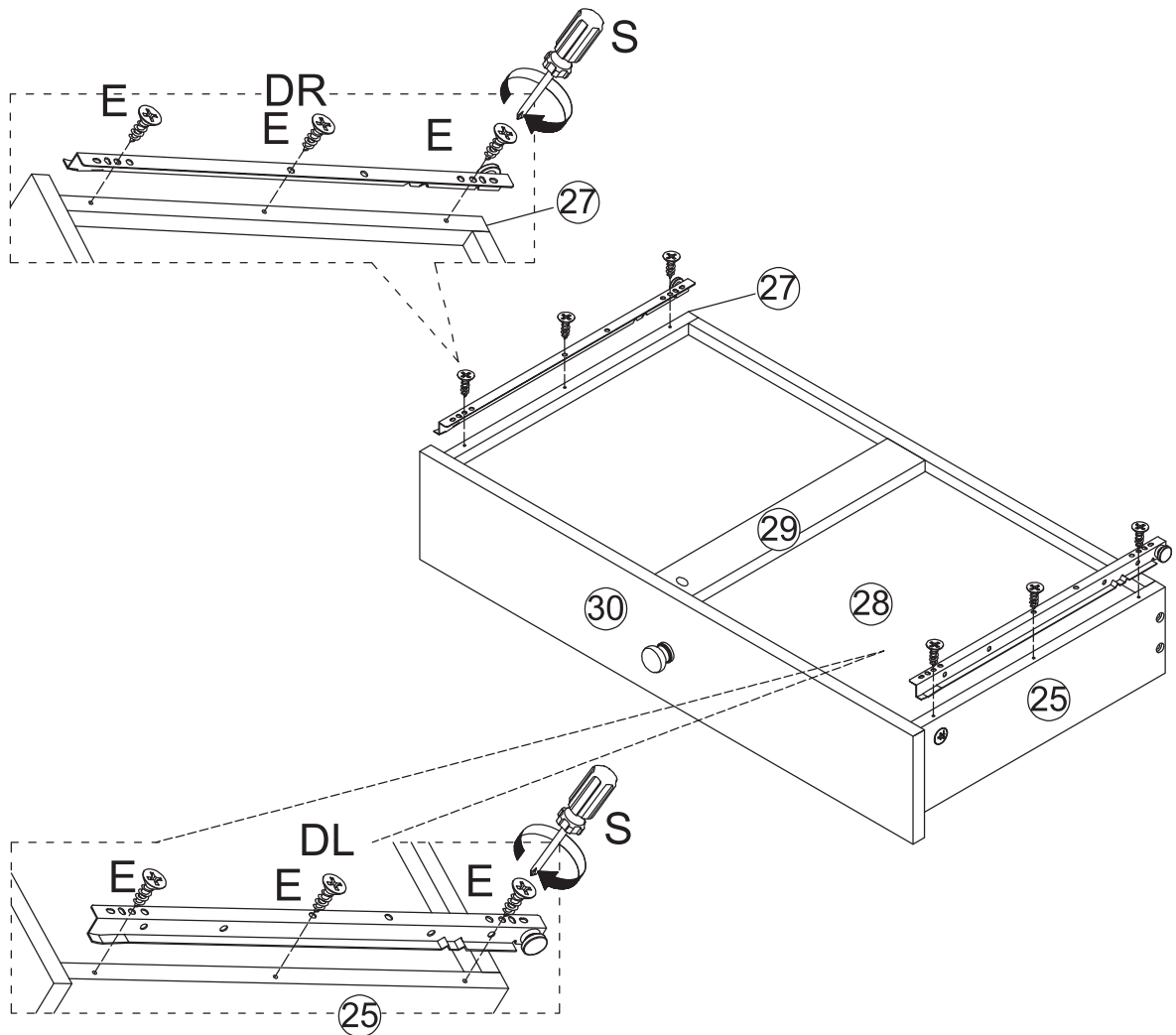

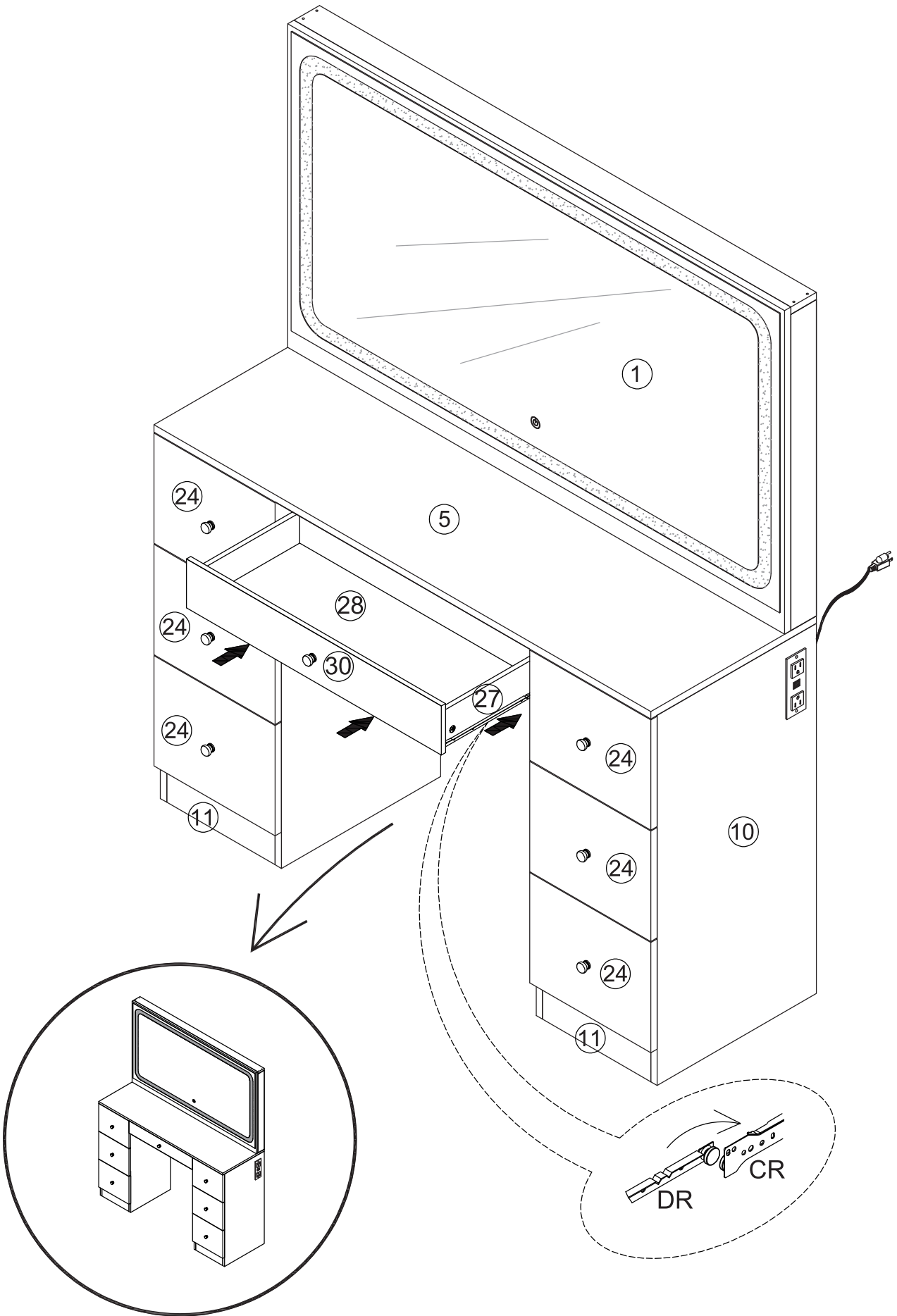
E	x6	DL	x1	DR	x1
					
		L350mm		L350mm	

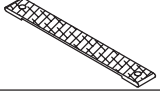

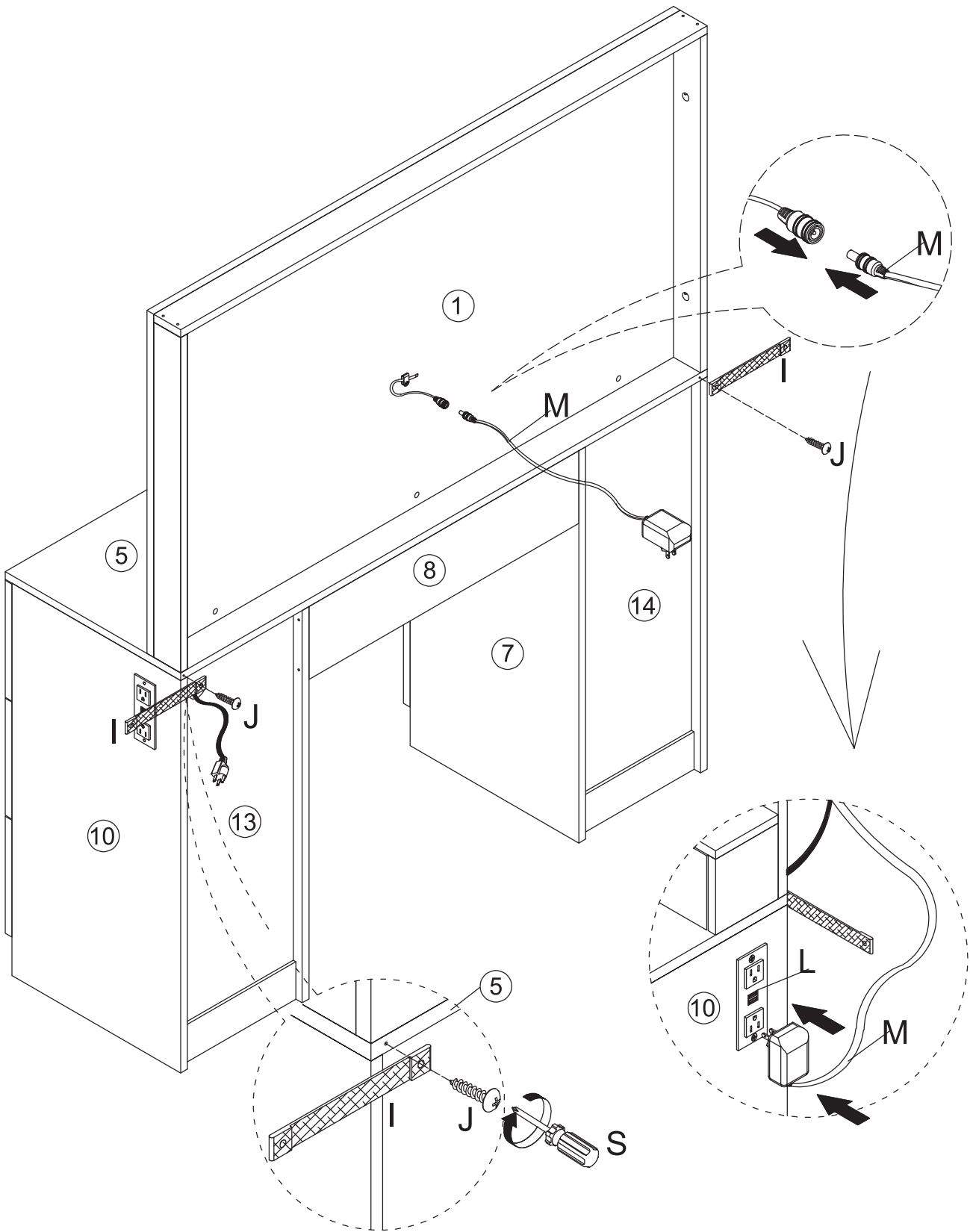

I	x2	J	x2	M	x1
					



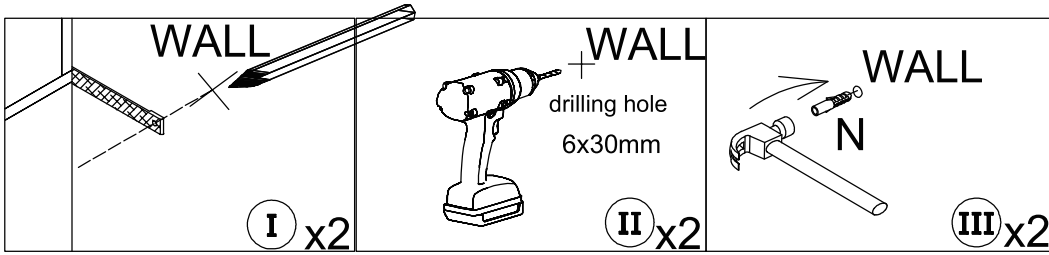

N	x2	D	x2
			

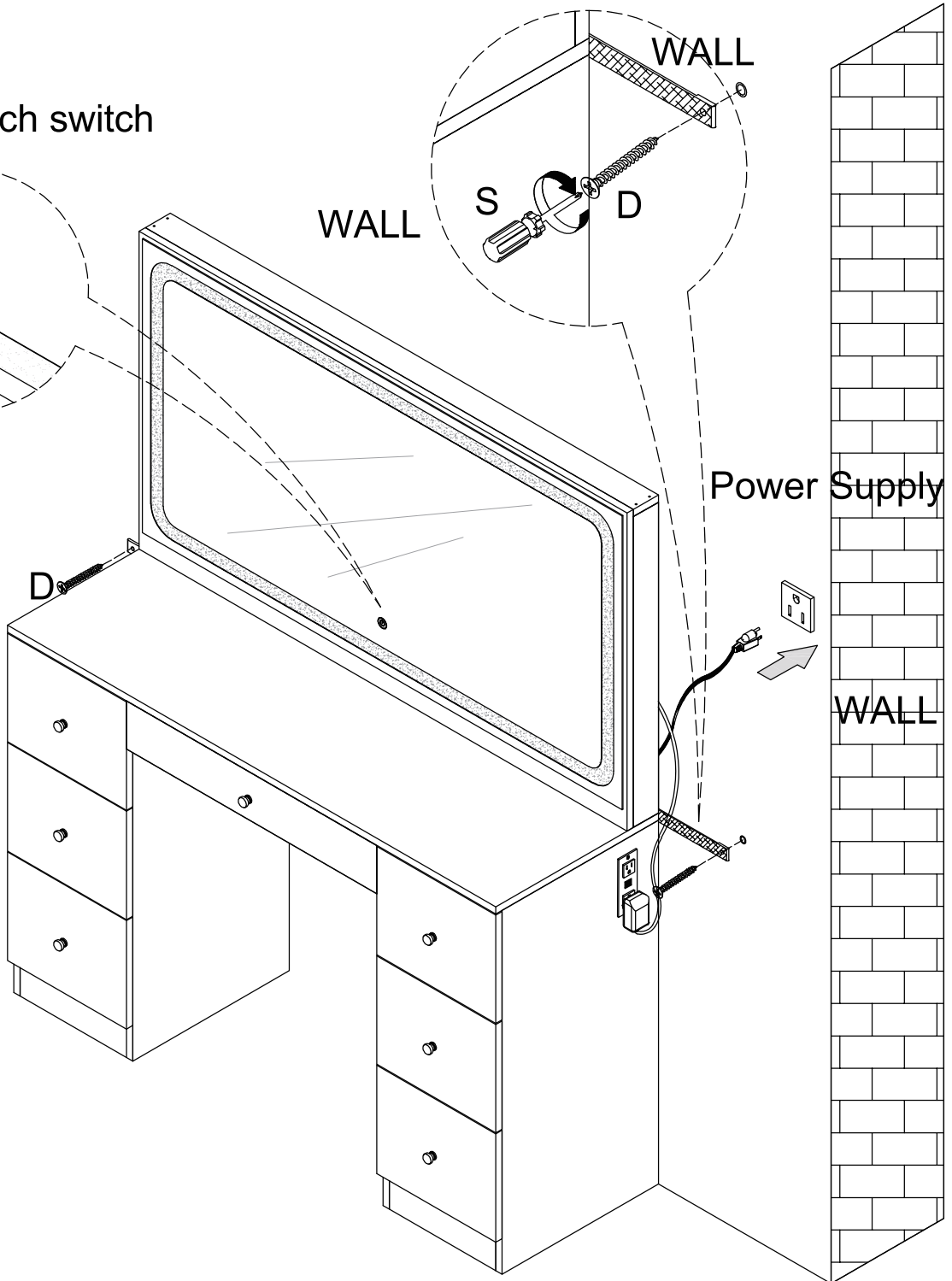
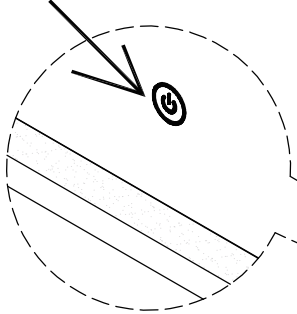

Lamp touch switch

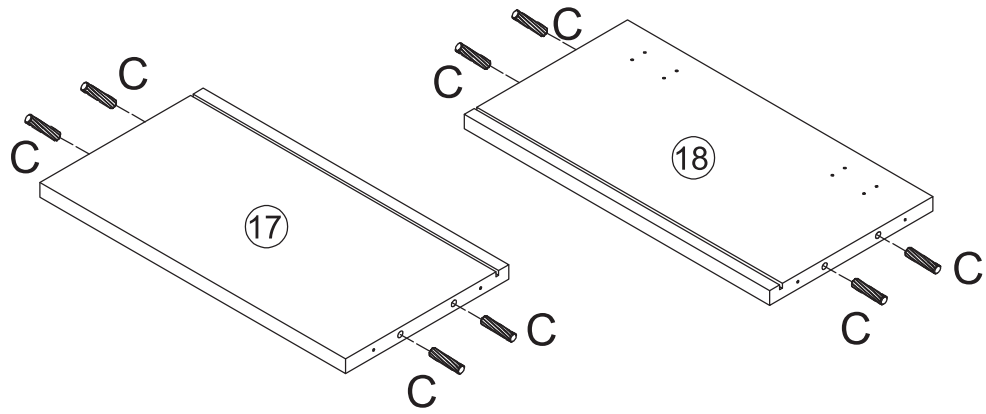





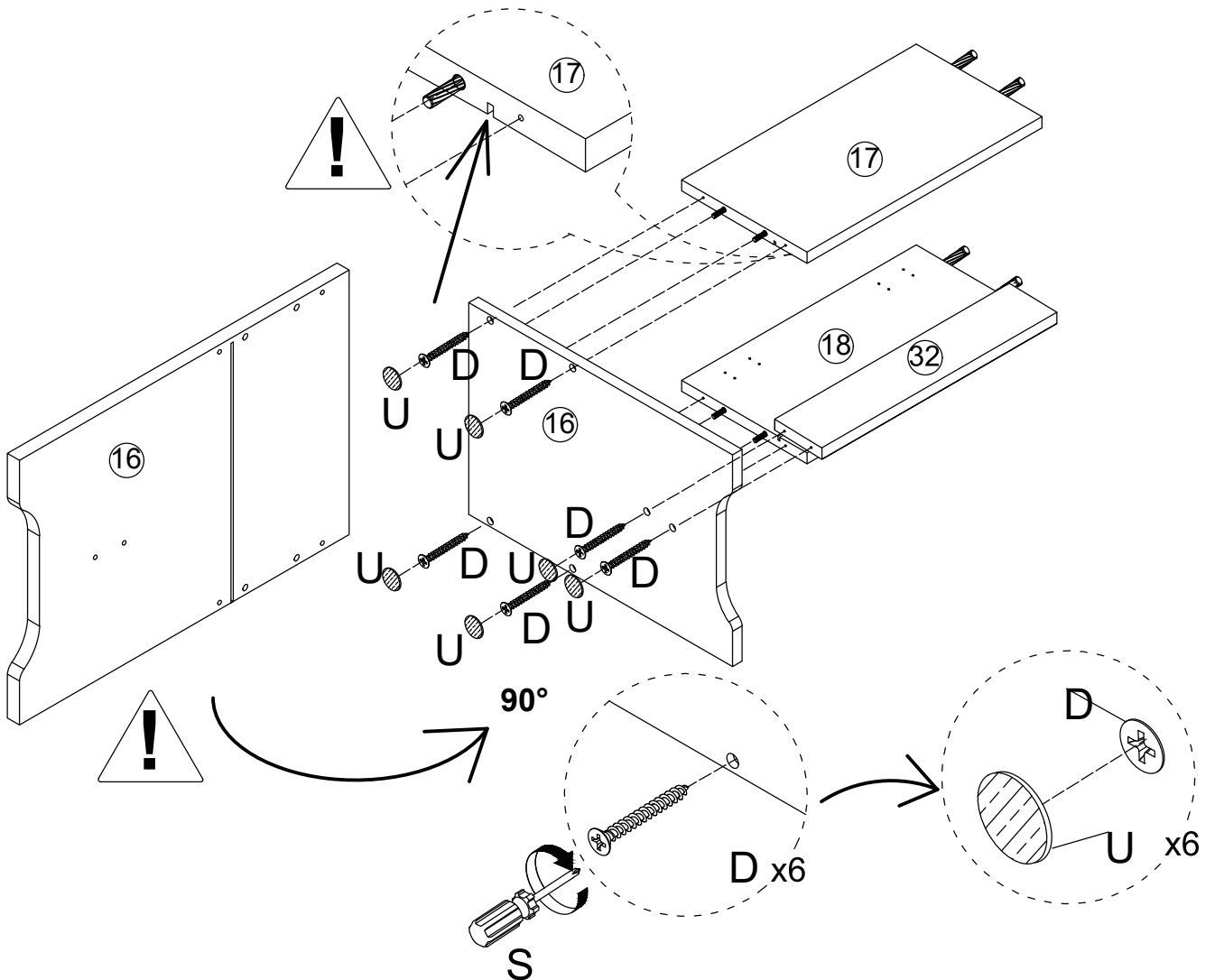

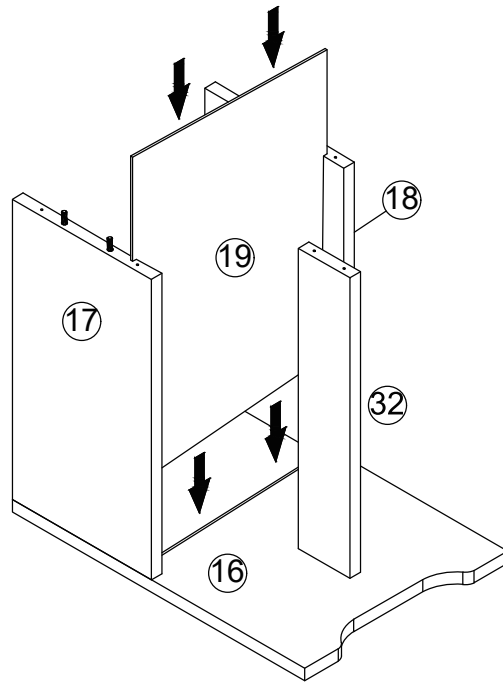
D	x4	U	x6
			



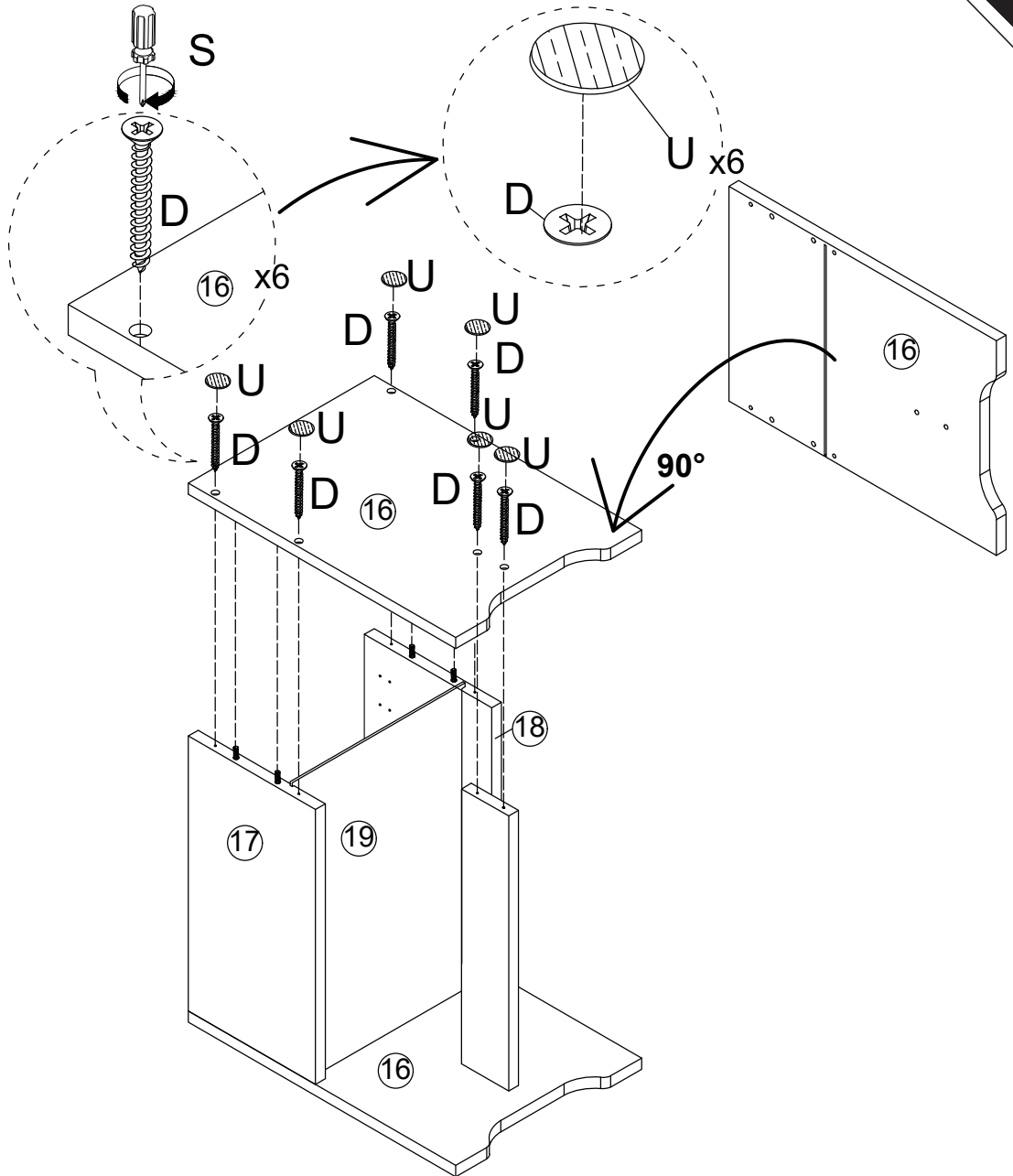

D	x4
	
U	x6
	

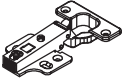

O	x2	P	x4
			

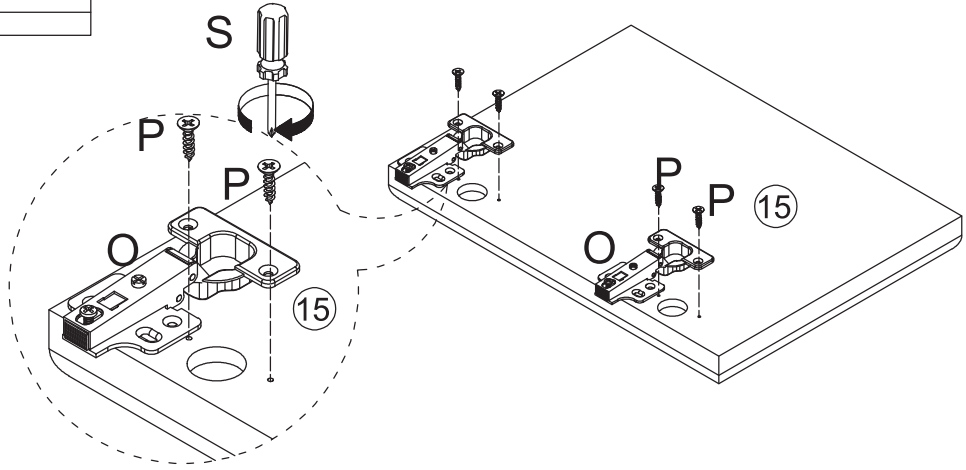

P	x8
