

# Assembly Instruction

Item: GMS05

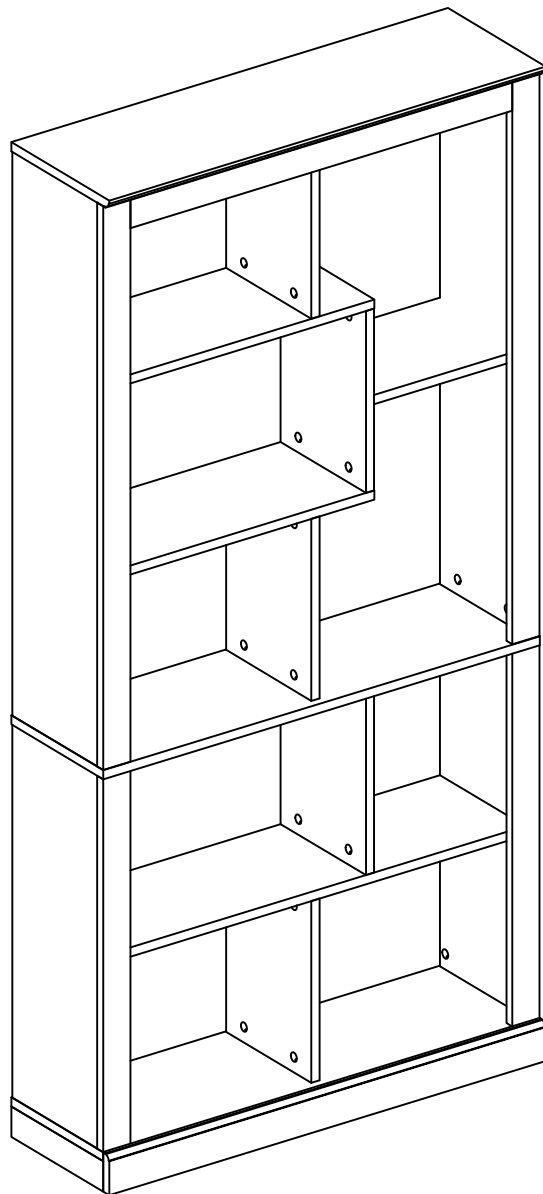

# ASSEMBLY INSTRUCTION

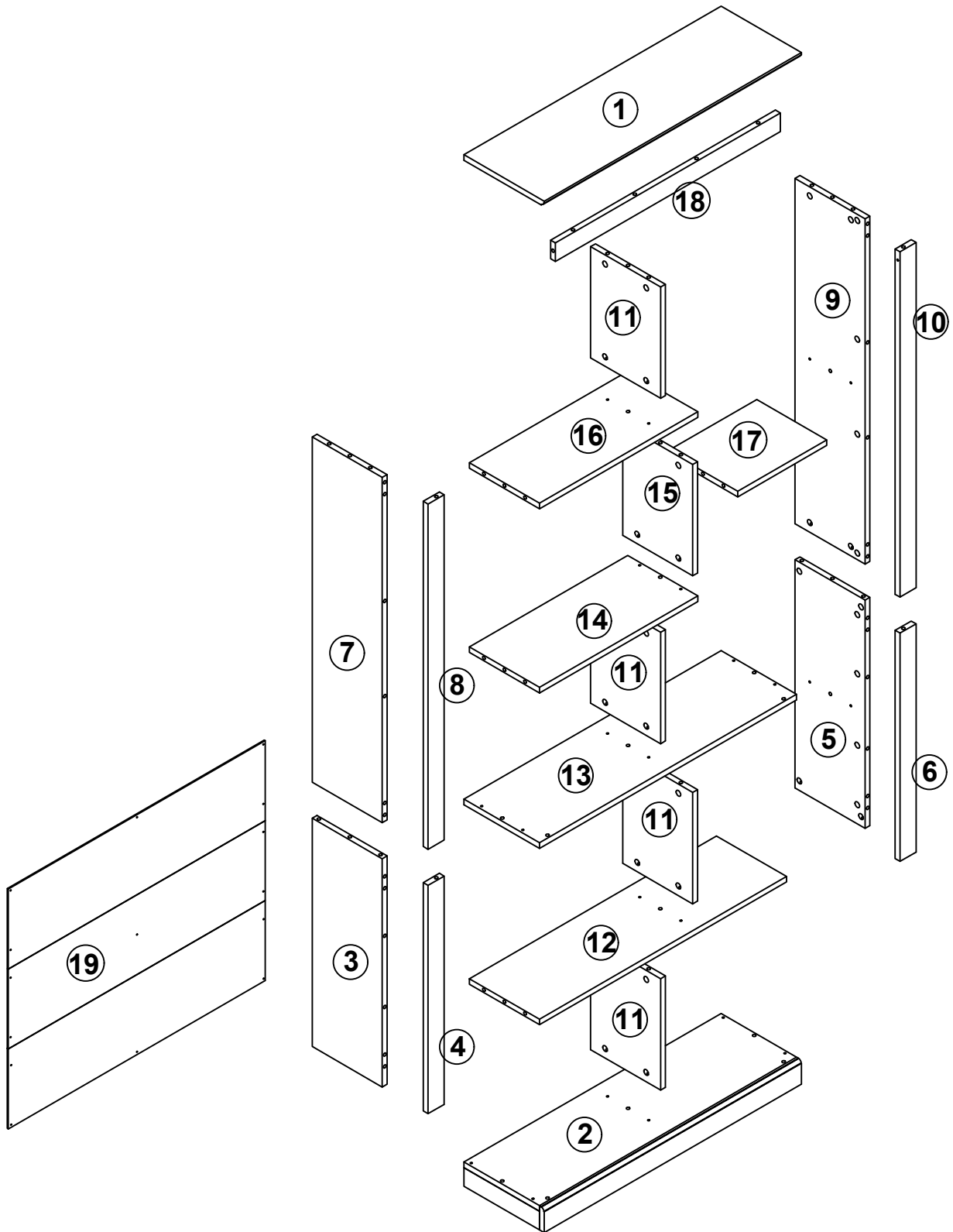

# HARDWARE

A x 70+4spare

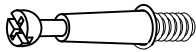

Ø6 x 32mm

B x 70+4spare

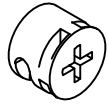

Ø15 x 10mm

C x 32+4spare

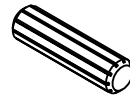

Ø8\*30mm

D x 4+1spare

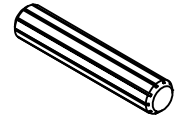

Ø8\*50mm

E x 6+2spare



Ø3.5\*14mm

F x 74

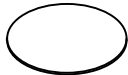

Ø20mm

G x 3

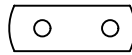

H x 2

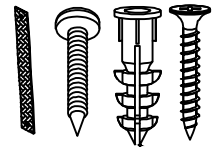

I x 15+2spare



Ø3\*12mm

## ASSEMBLY INSTRUCTION

## Installation of Cams and Pins

Screw the pin into the hole. To set the cams correctly, ensure that the arrow on the cam is opening to the hole of the pin it is locking. Lock the cam by turning the cam head with a screwdriver until it is tightened. Please do not use an electric screwdriver to assemble the unit.

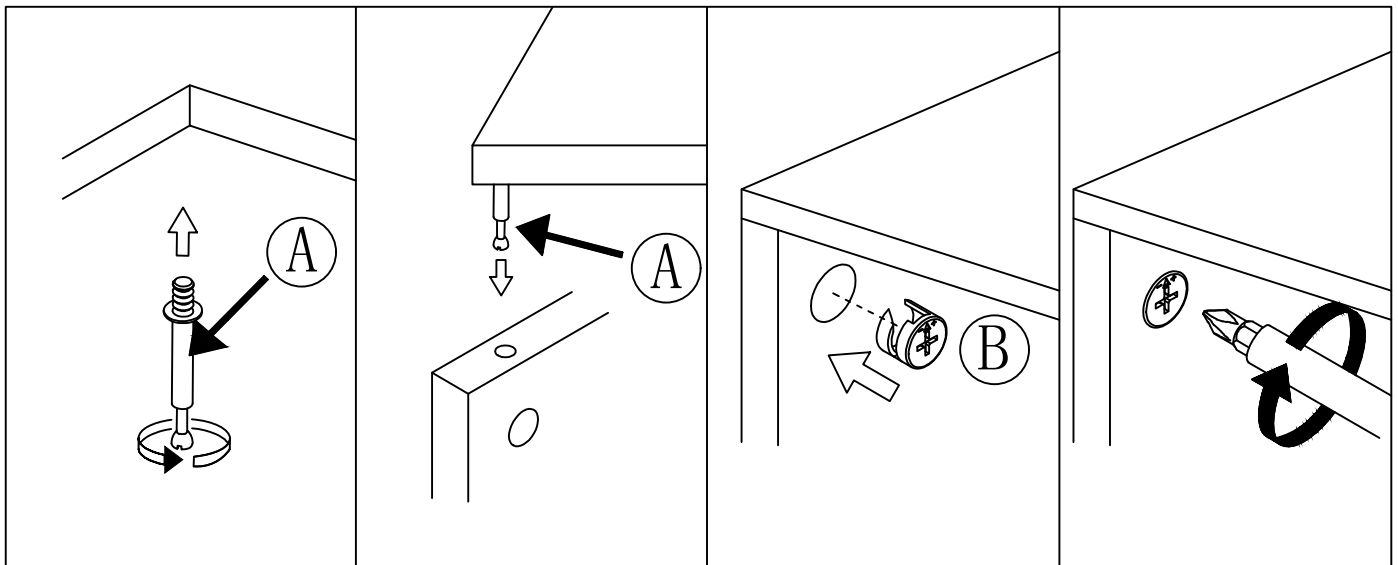

Read each step carefully before starting. It is very important that each step of instruction is performed in the correct order. If these steps are not followed in sequence, assembly difficulties will occur.

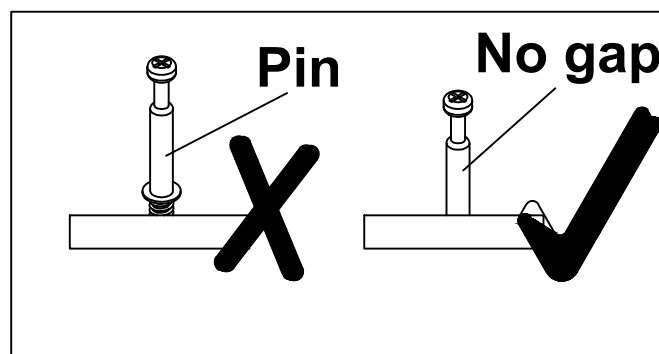

# ASSEMBLY INSTRUCTION

## STEP 1

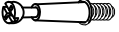
A:  6PCS

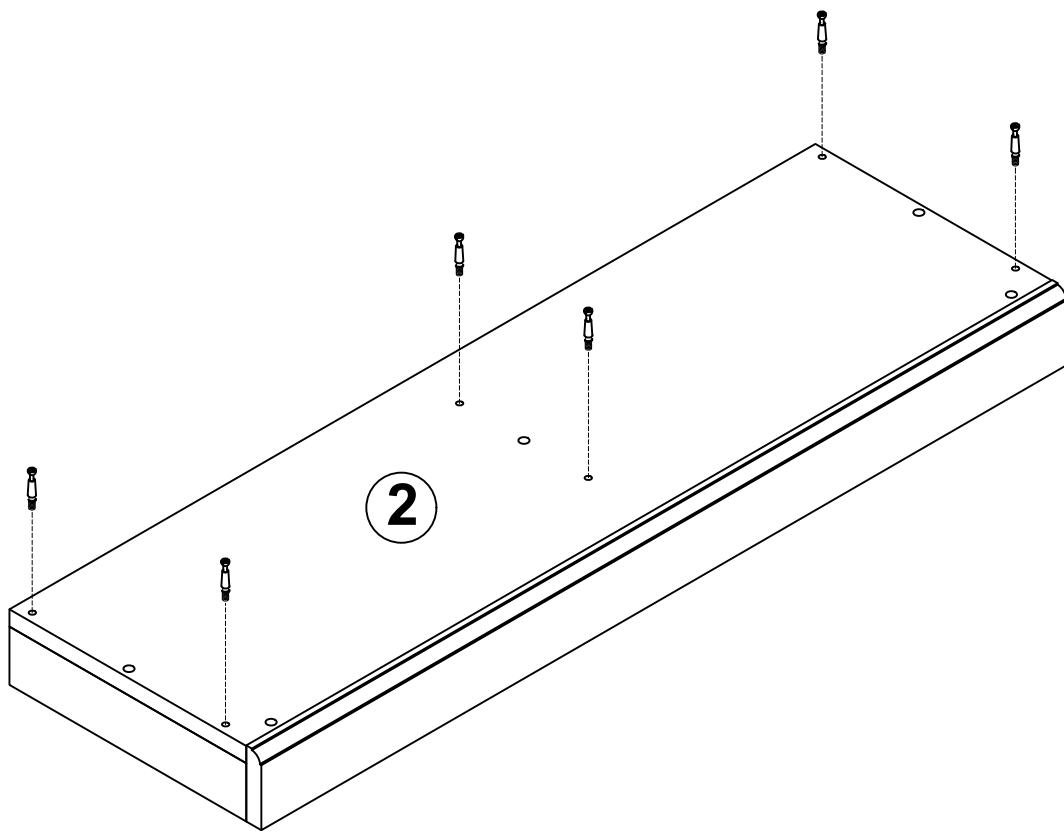

# ASSEMBLY INSTRUCTION

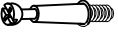

## STEP 2

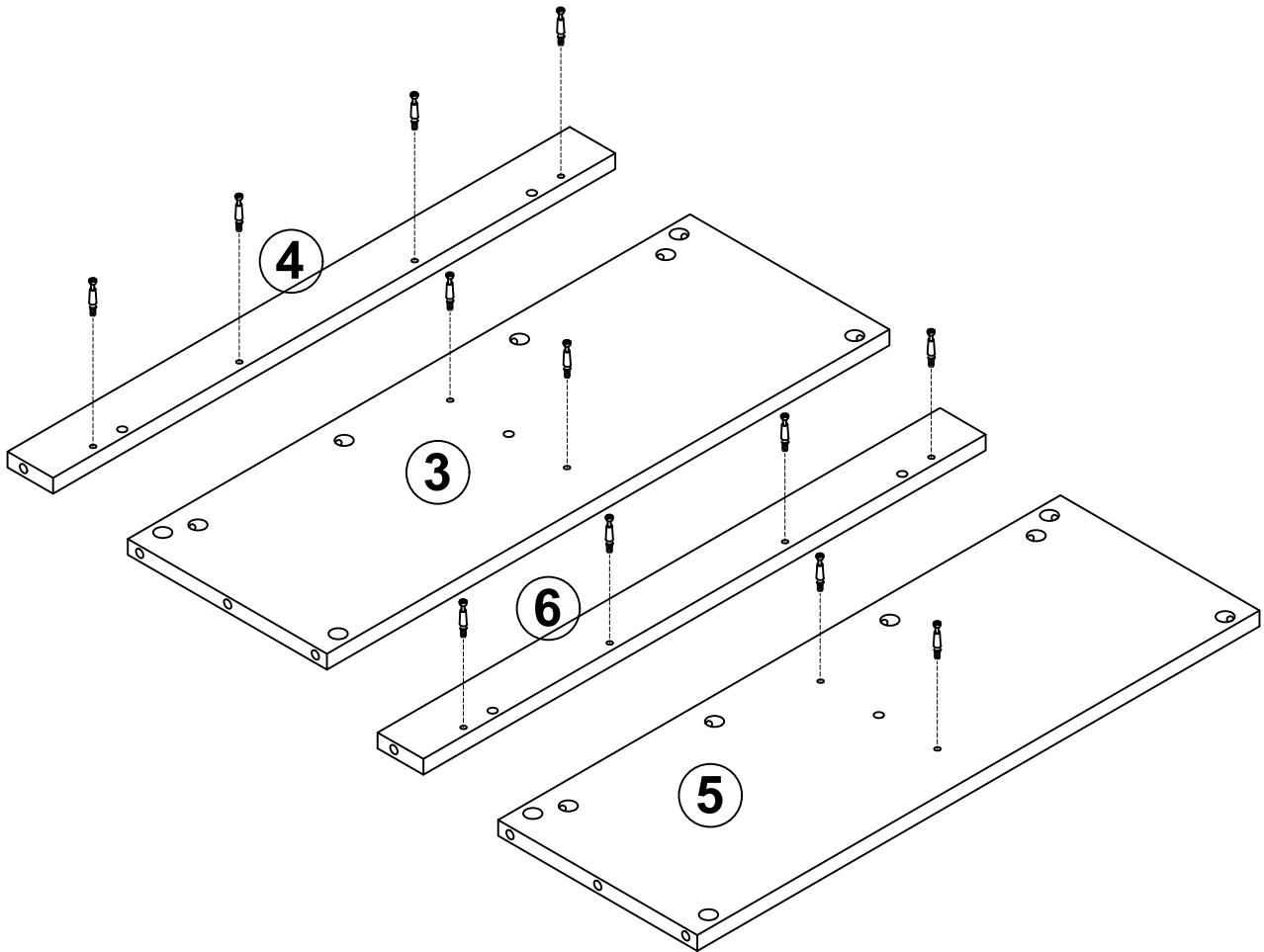
A:  12PCS



# ASSEMBLY INSTRUCTION

## STEP 3

B:		8PCS
C:		4PCS

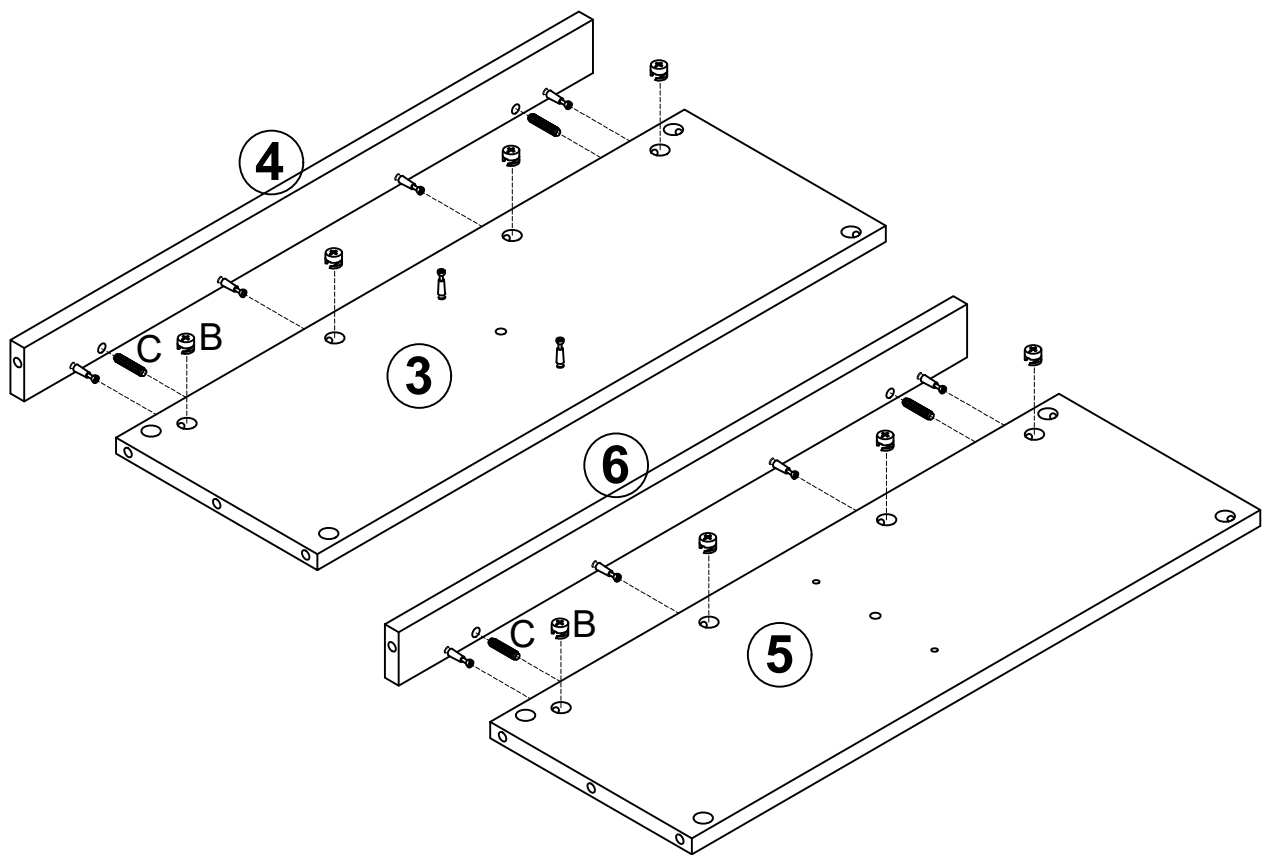

# ASSEMBLY INSTRUCTION

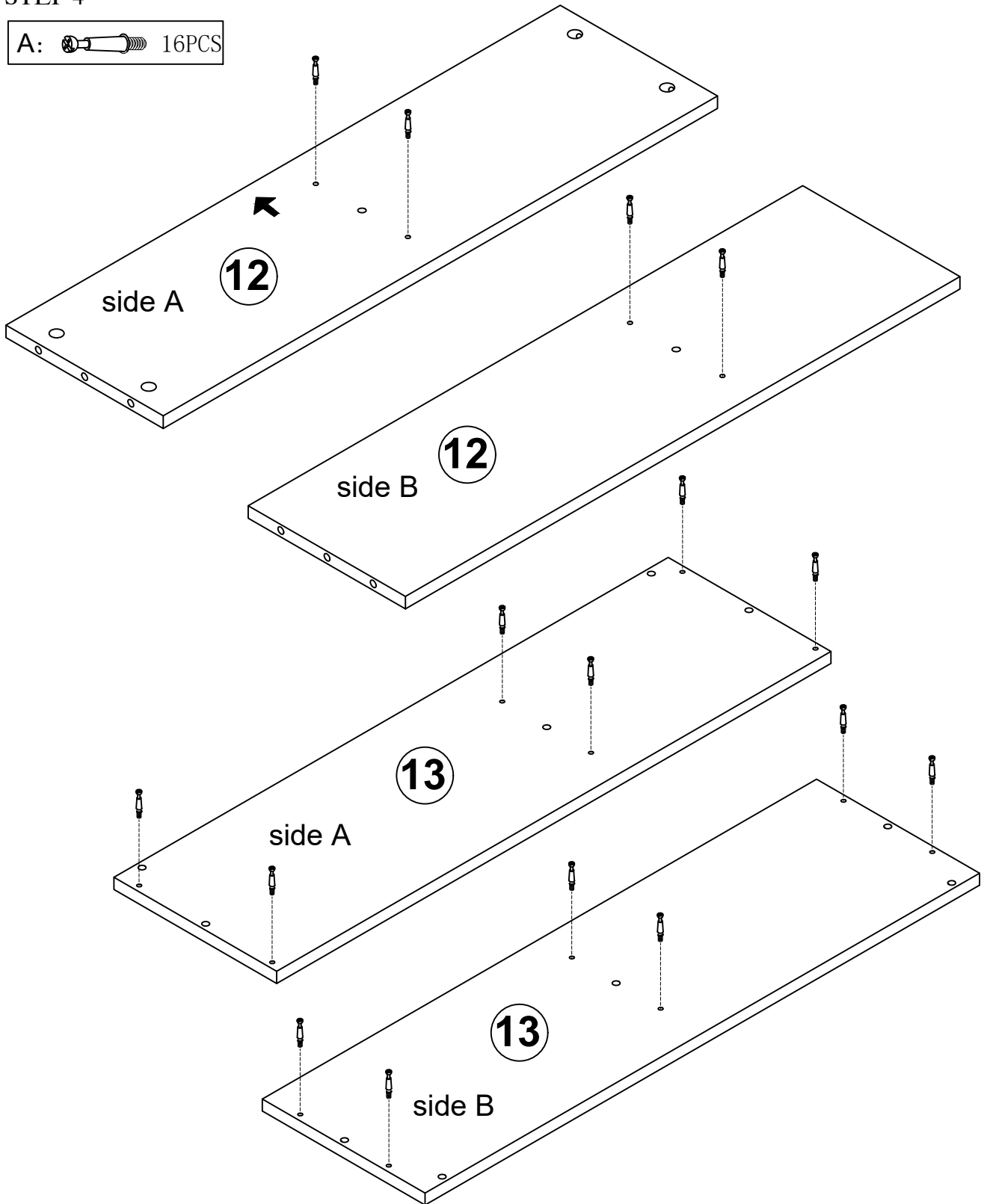

## STEP 4

A:  16PCS





# ASSEMBLY INSTRUCTION

## STEP 5

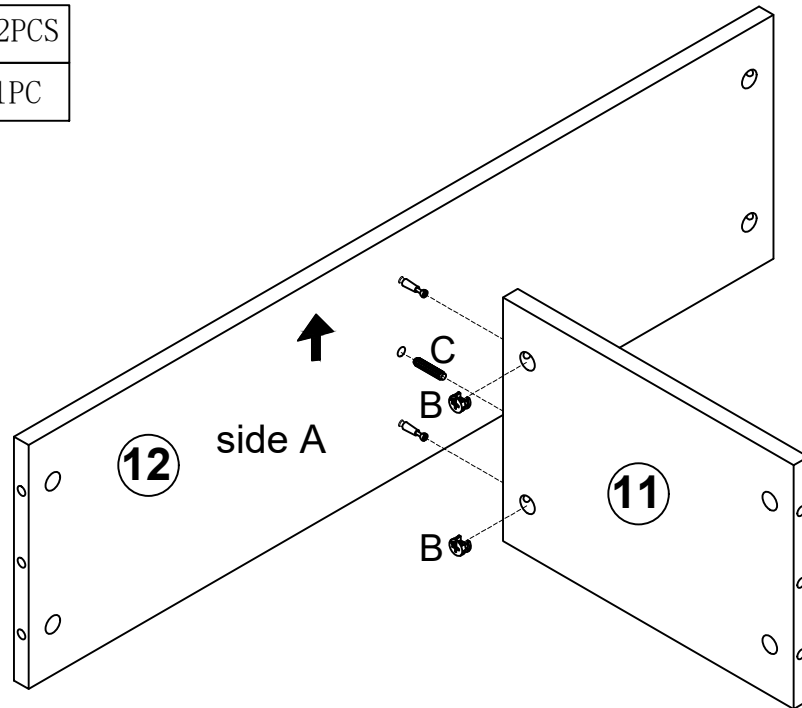
B:		2PCS
C:		1PC



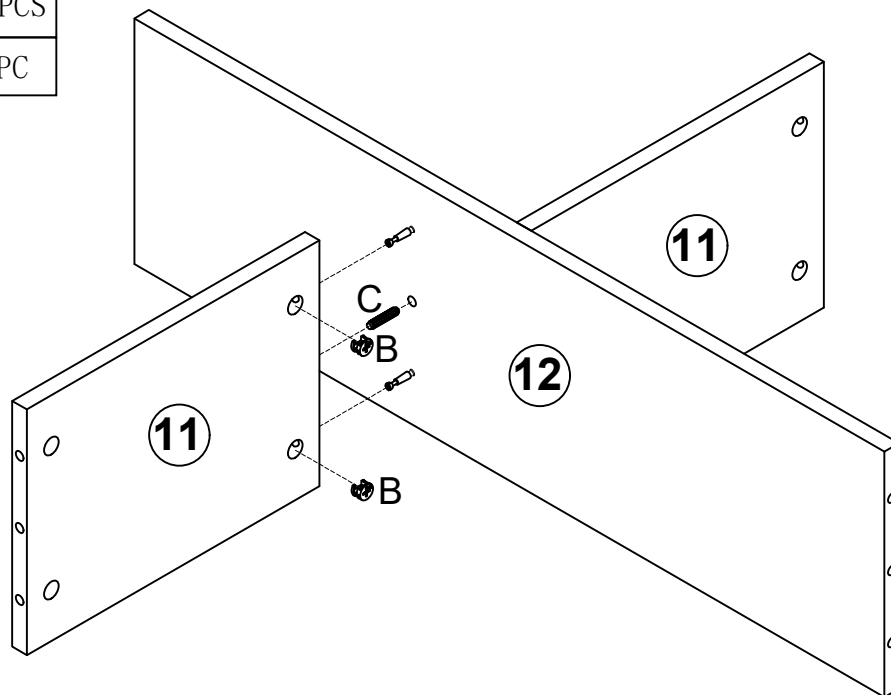

## STEP 6

B:		2PCS
C:		1PC





# ASSEMBLY INSTRUCTION

## STEP 7

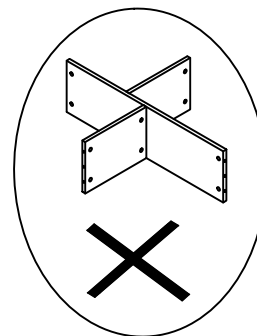
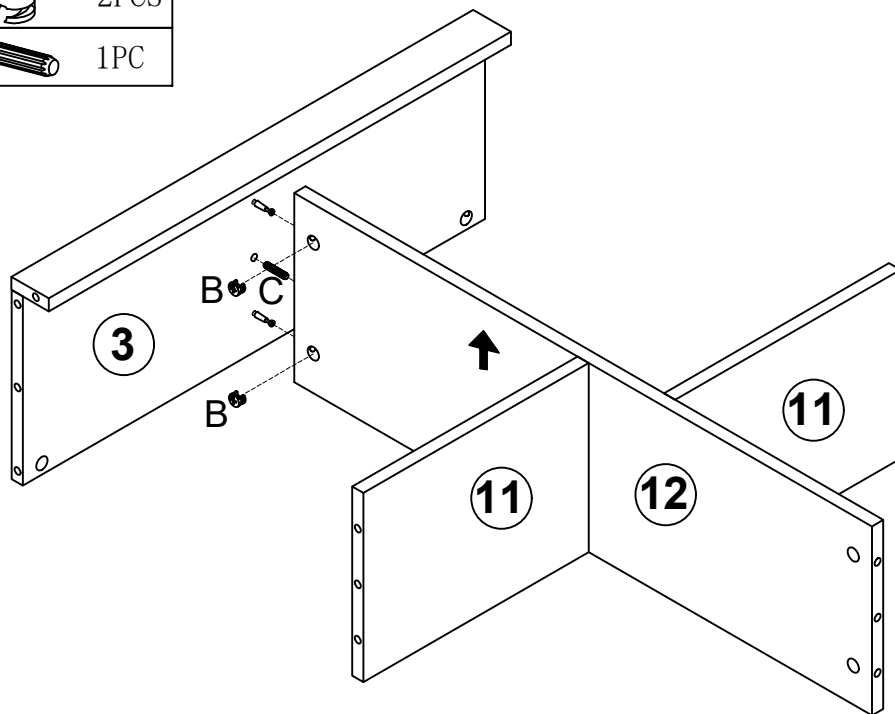
B:		2PCS
C:		1PC



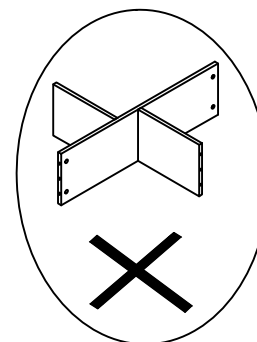
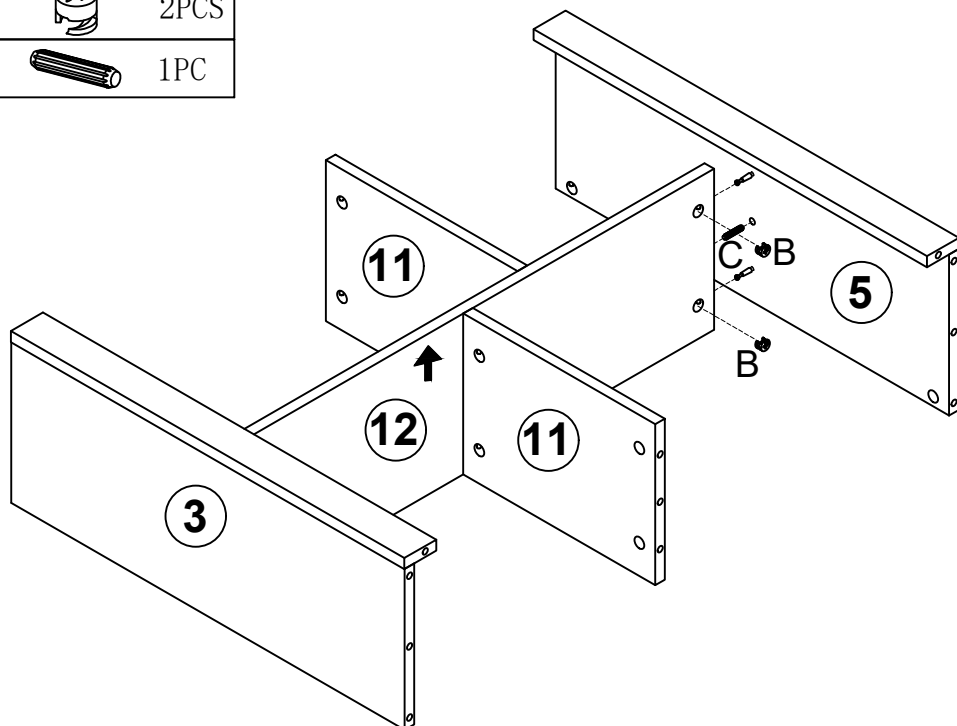

## STEP 8

B:		2PCS
C:		1PC





# ASSEMBLY INSTRUCTION

## STEP 9

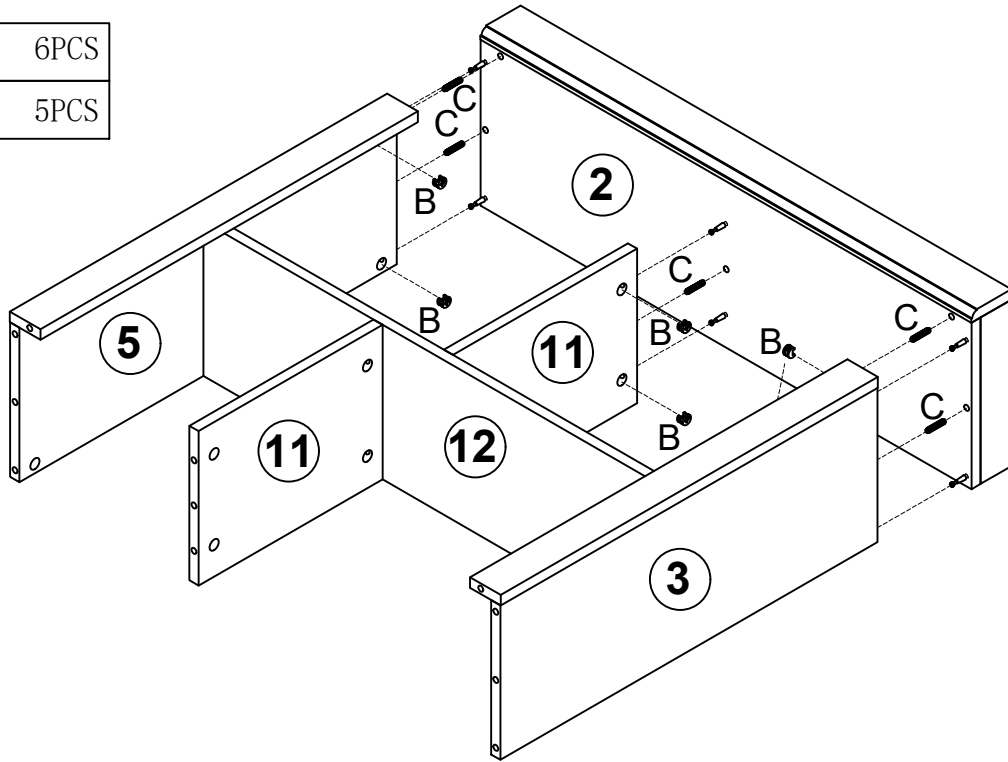
B:		6PCS
C:		5PCS



## STEP 10

B:		6PCS
C:		1PC
D:		4PCS

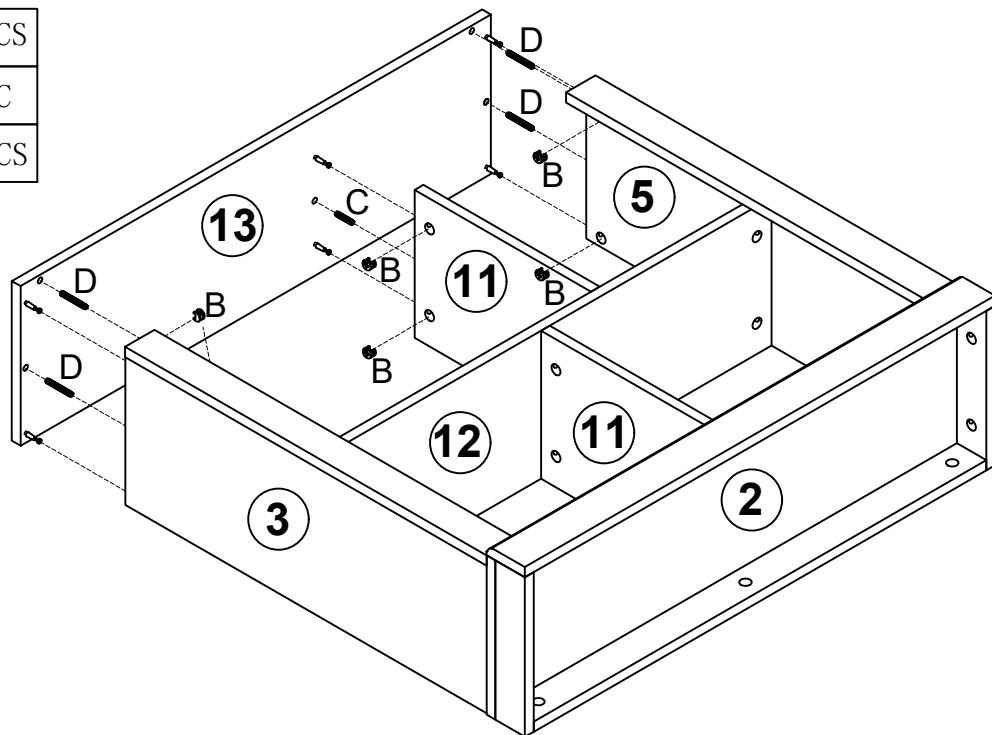

# ASSEMBLY INSTRUCTION

## STEP 11

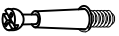
A:  6PCS

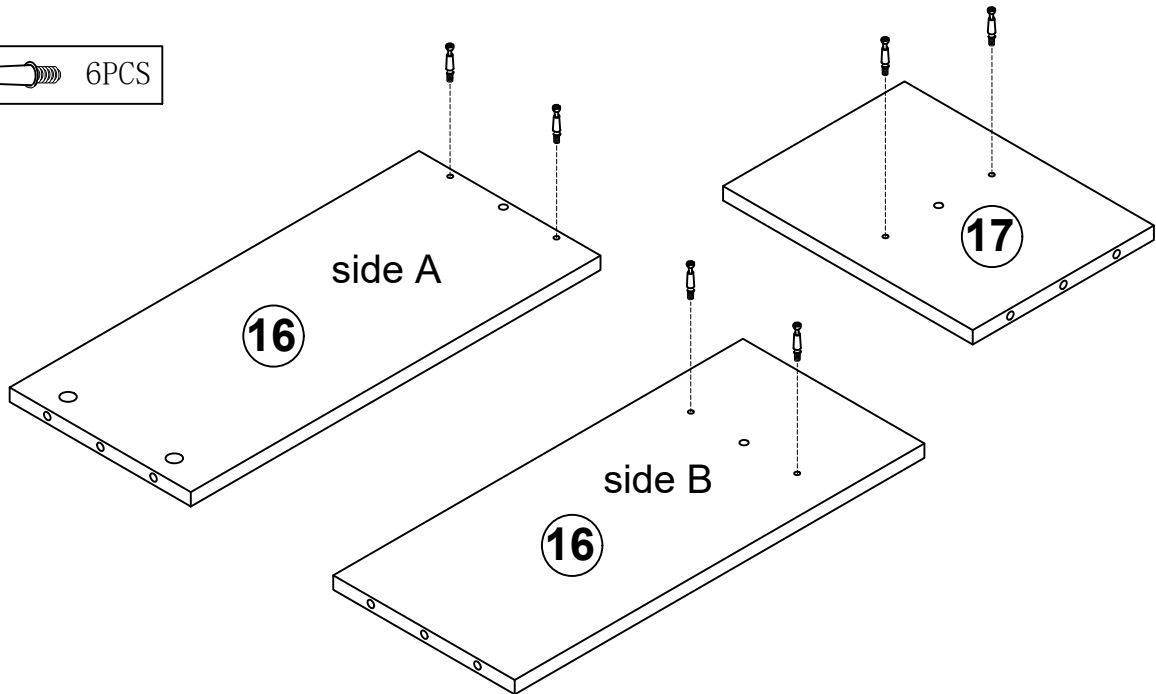

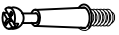

## STEP 12

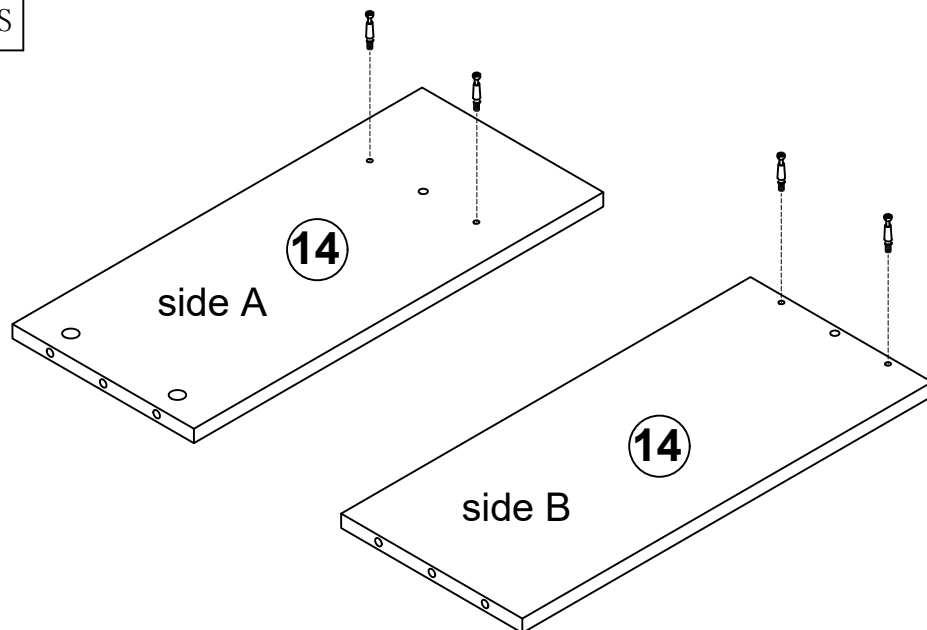
A:  4PCS





# ASSEMBLY INSTRUCTION

## STEP 13

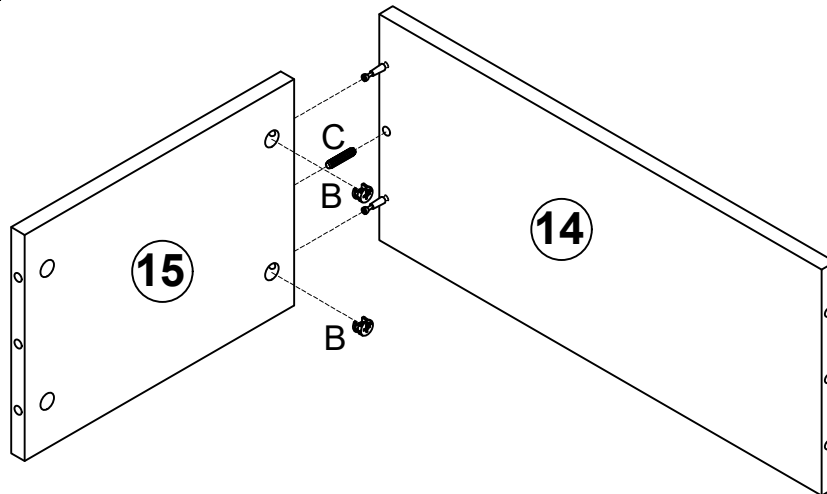
B:		2PCS
C:		1PC



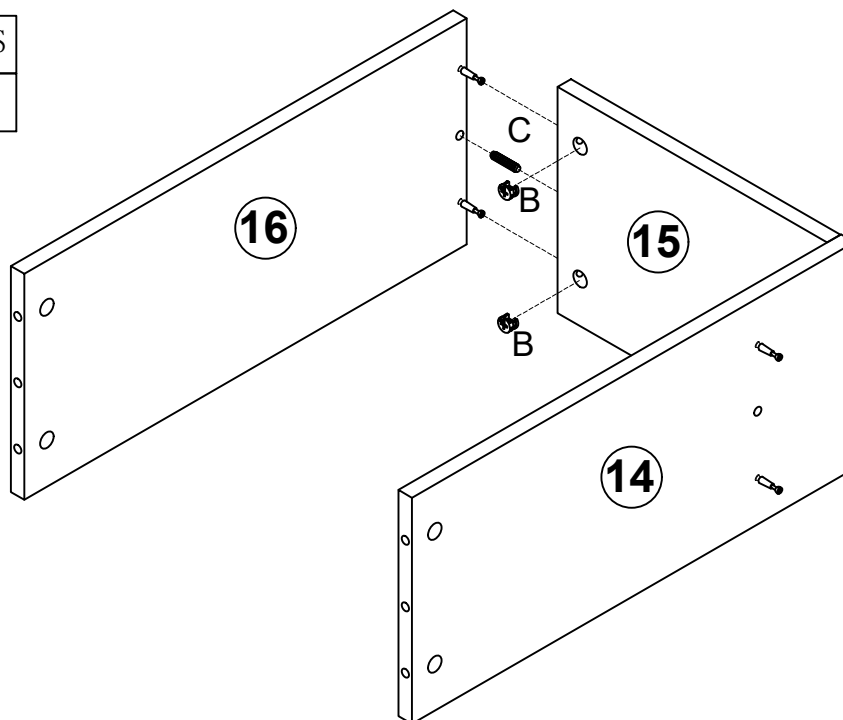

## STEP 14

B:		2PCS
C:		1PC





# ASSEMBLY INSTRUCTION

## STEP 15

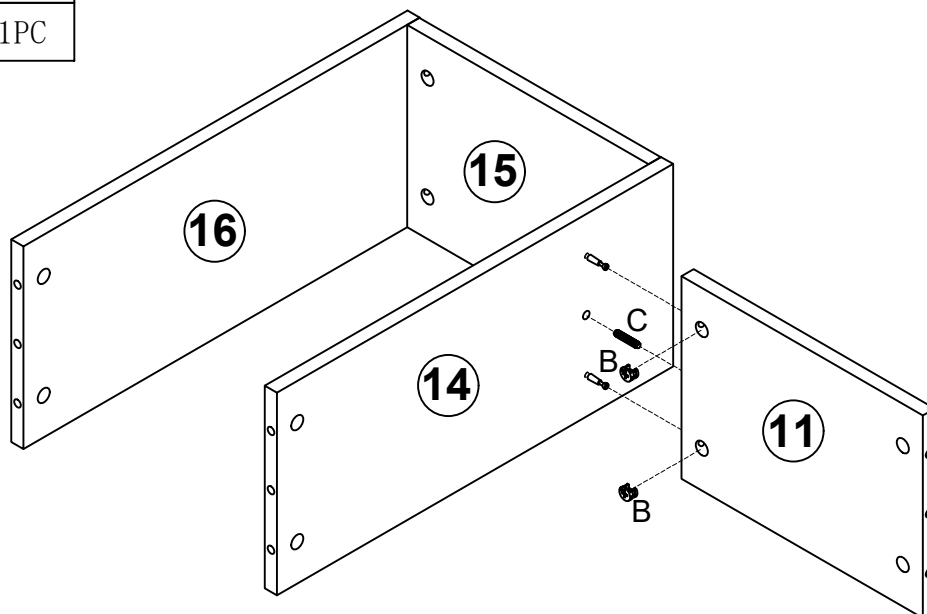
B:		2PCS
C:		1PC



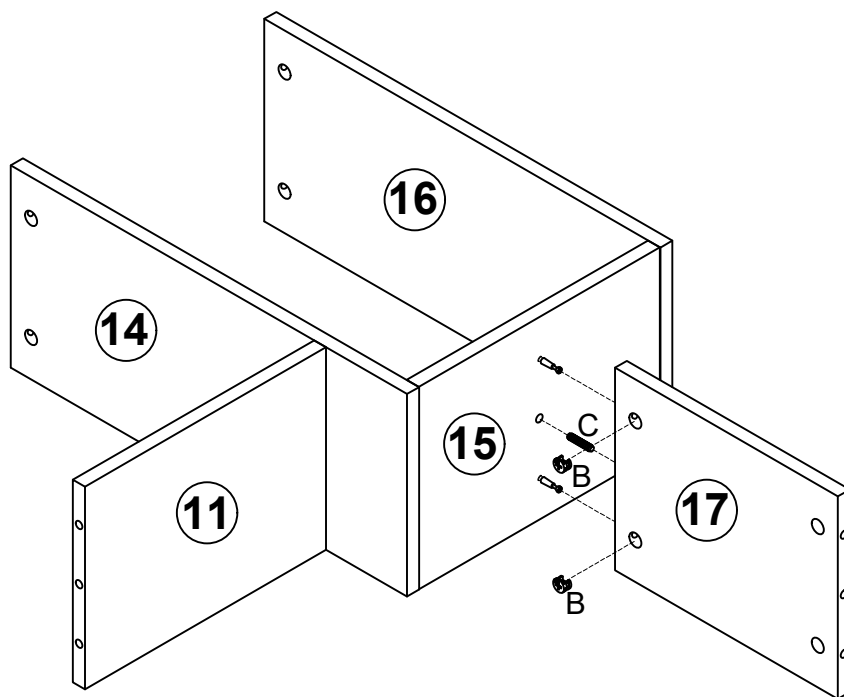

## STEP 16

B:		2PCS
C:		1PC



# ASSEMBLY INSTRUCTION

## STEP 17

B:		2PCS
C:		1PC

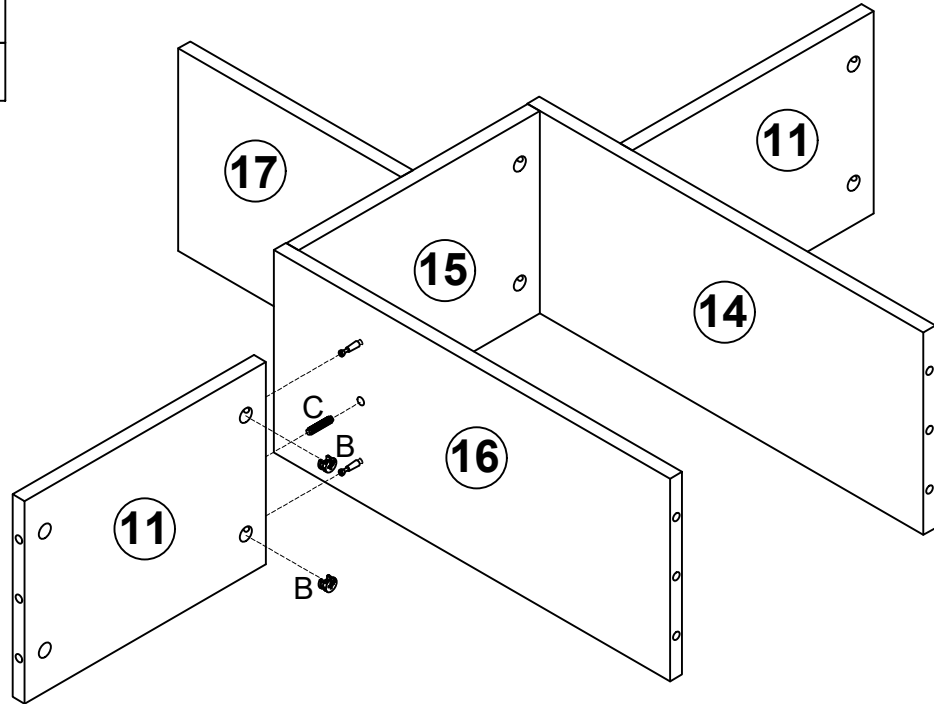

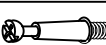

## STEP 18

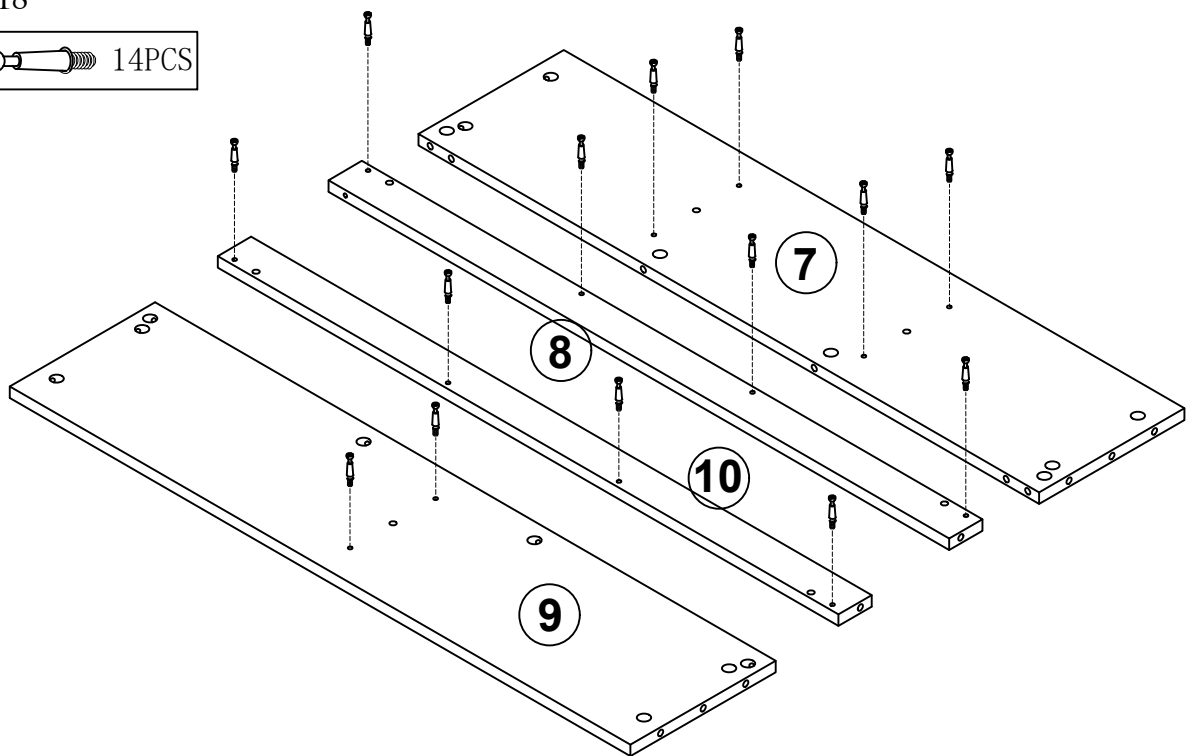
A:		14PCS
----	---	-------



# ASSEMBLY INSTRUCTION

## STEP 19

B:		8PCS
C:		4PCS

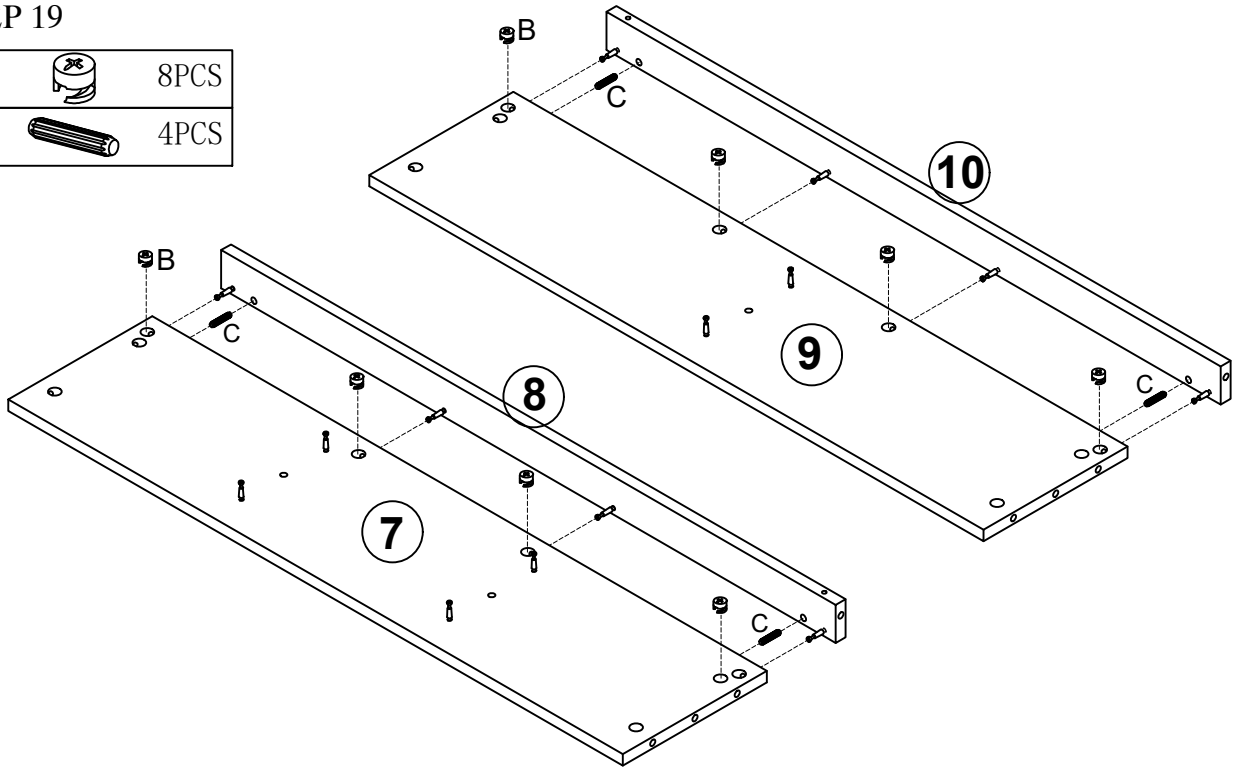

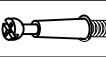

## STEP 20

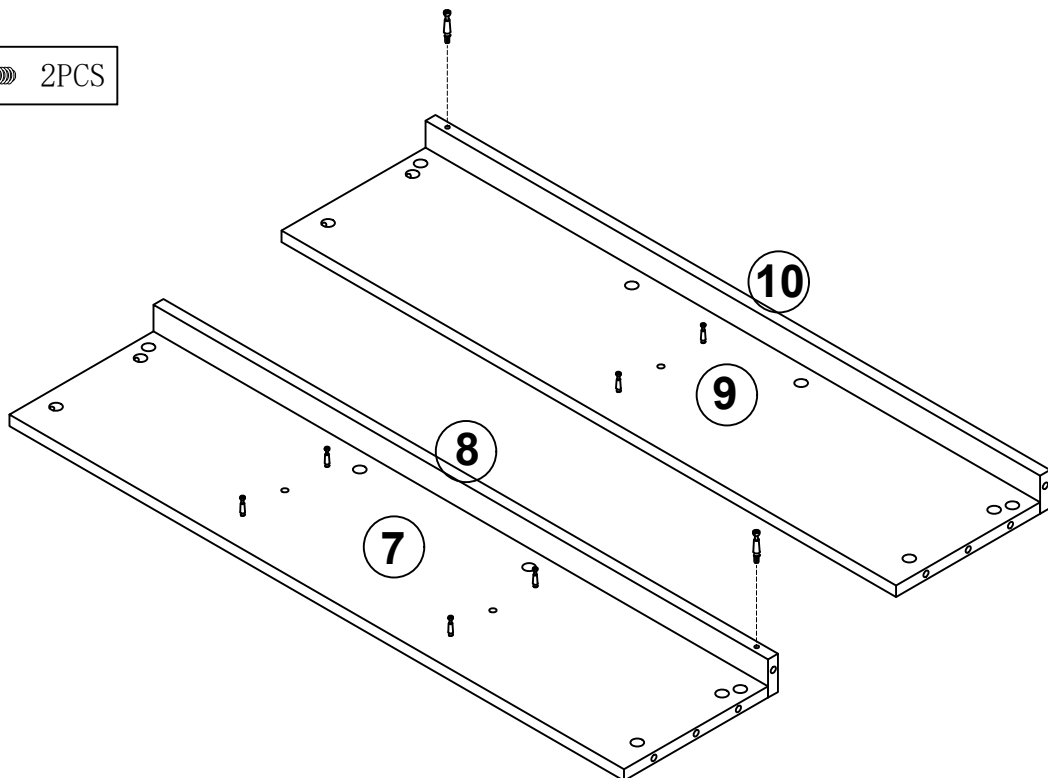
A:		2PCS
----	---	------





# ASSEMBLY INSTRUCTION

## STEP 21

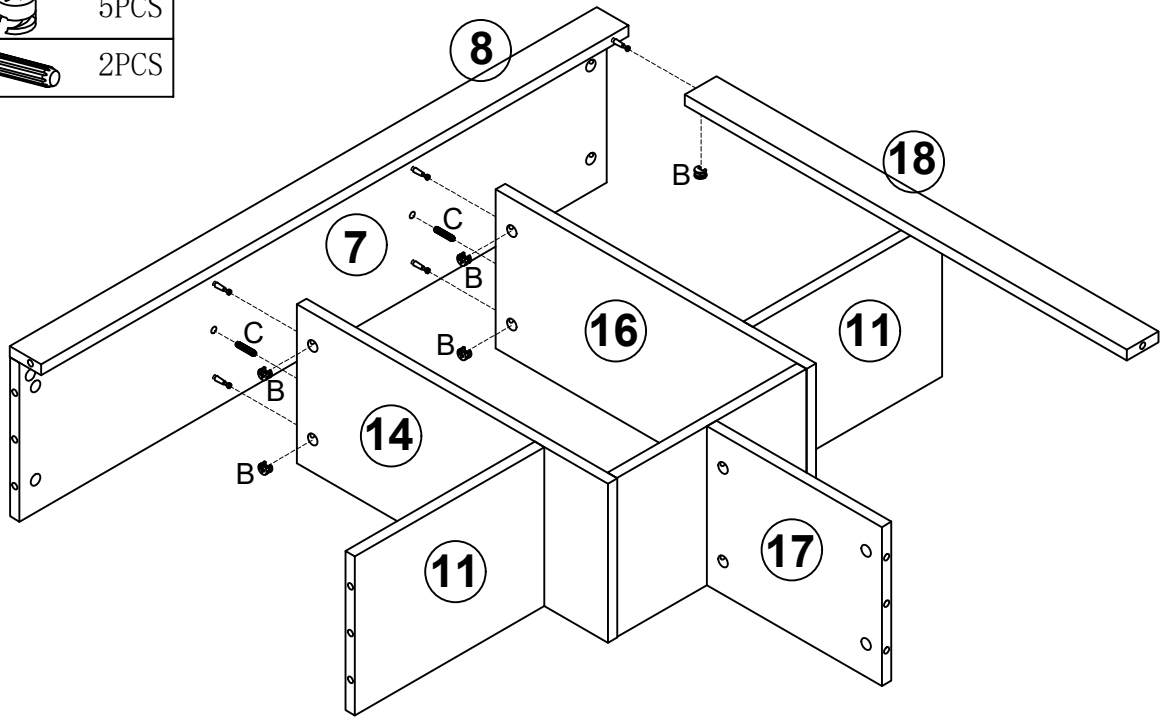
B:		5PCS
C:		2PCS



## STEP 22

B:		3PCS
C:		1PCS

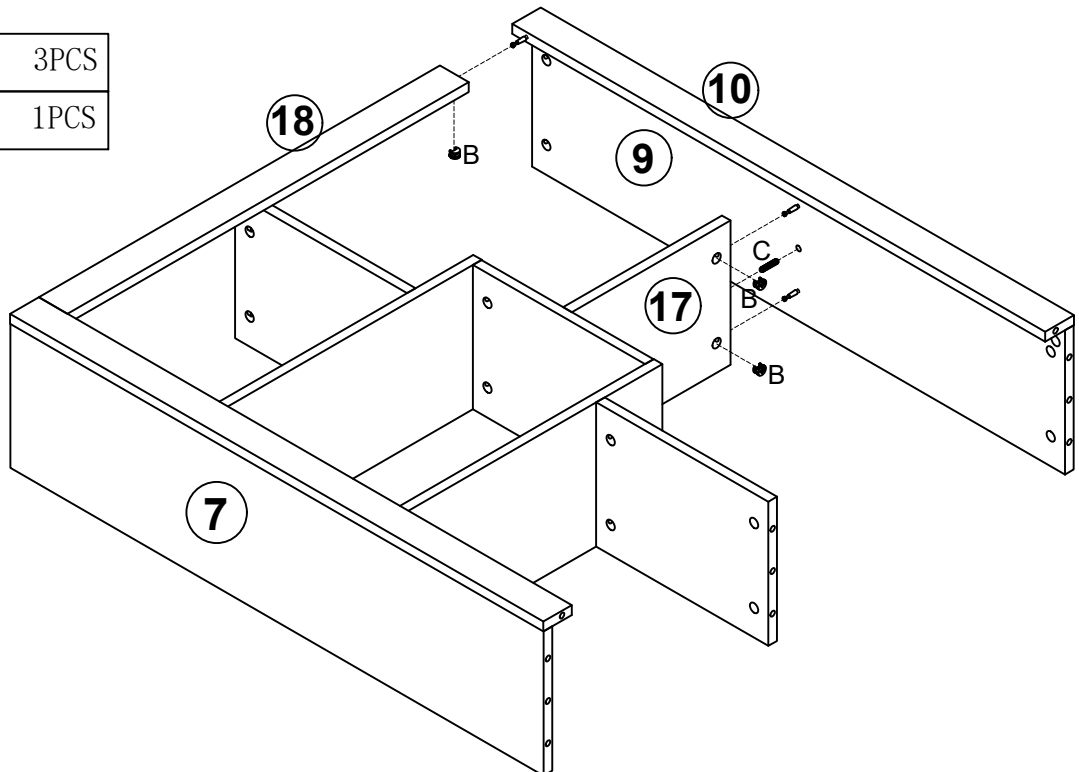

# ASSEMBLY INSTRUCTION

## STEP 23

A:  10PCS

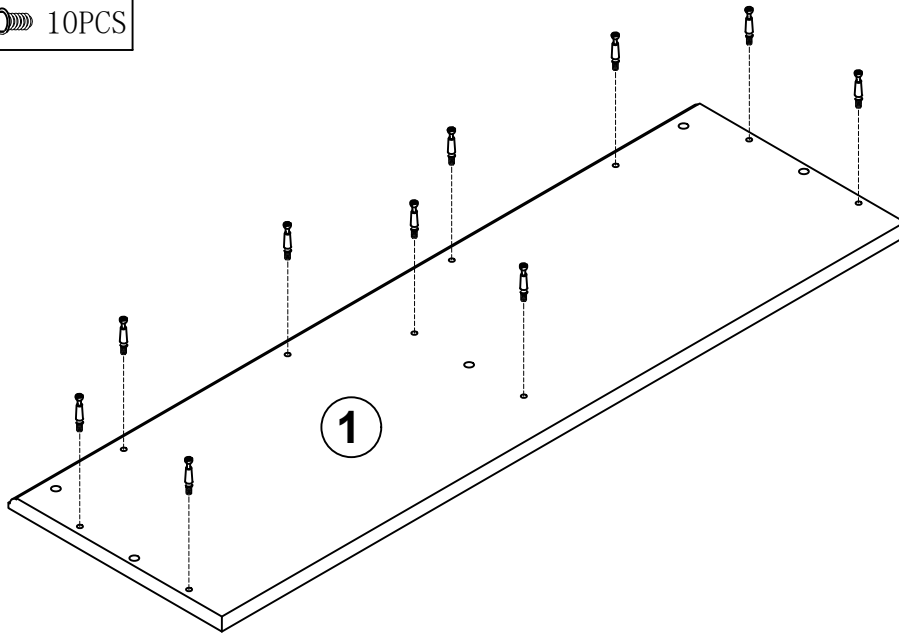

## STEP 24

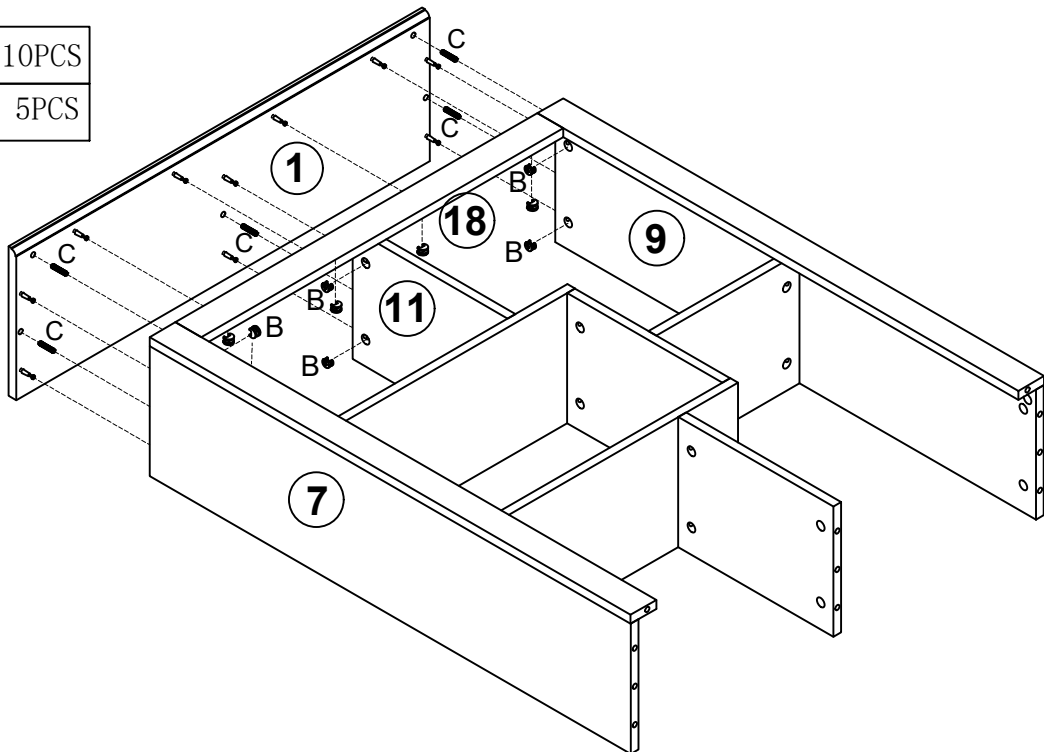

B:  10PCS

C:  5PCS



# ASSEMBLY INSTRUCTION

## STEP 25

- |    |   |      |
|----|---|------|
| B: |  | 6PCS |
| C: |  | 1PC  |

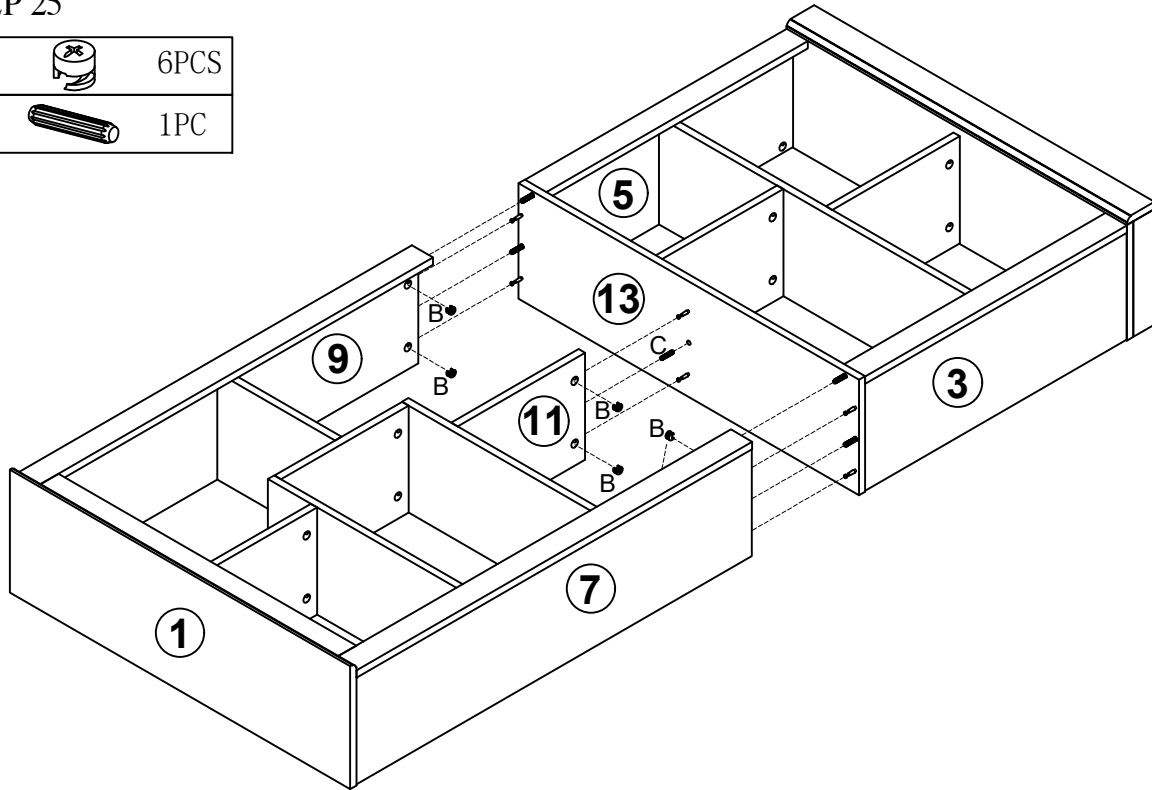

## STEP 26

- |    |   |       |
|----|---|-------|
| F: |  | 74PCS |
|----|---|-------|

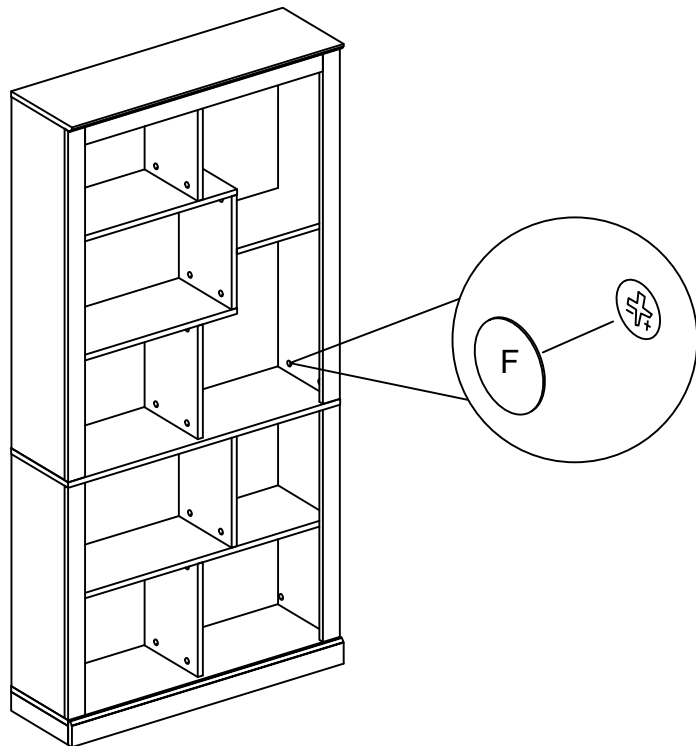

# ASSEMBLY INSTRUCTION

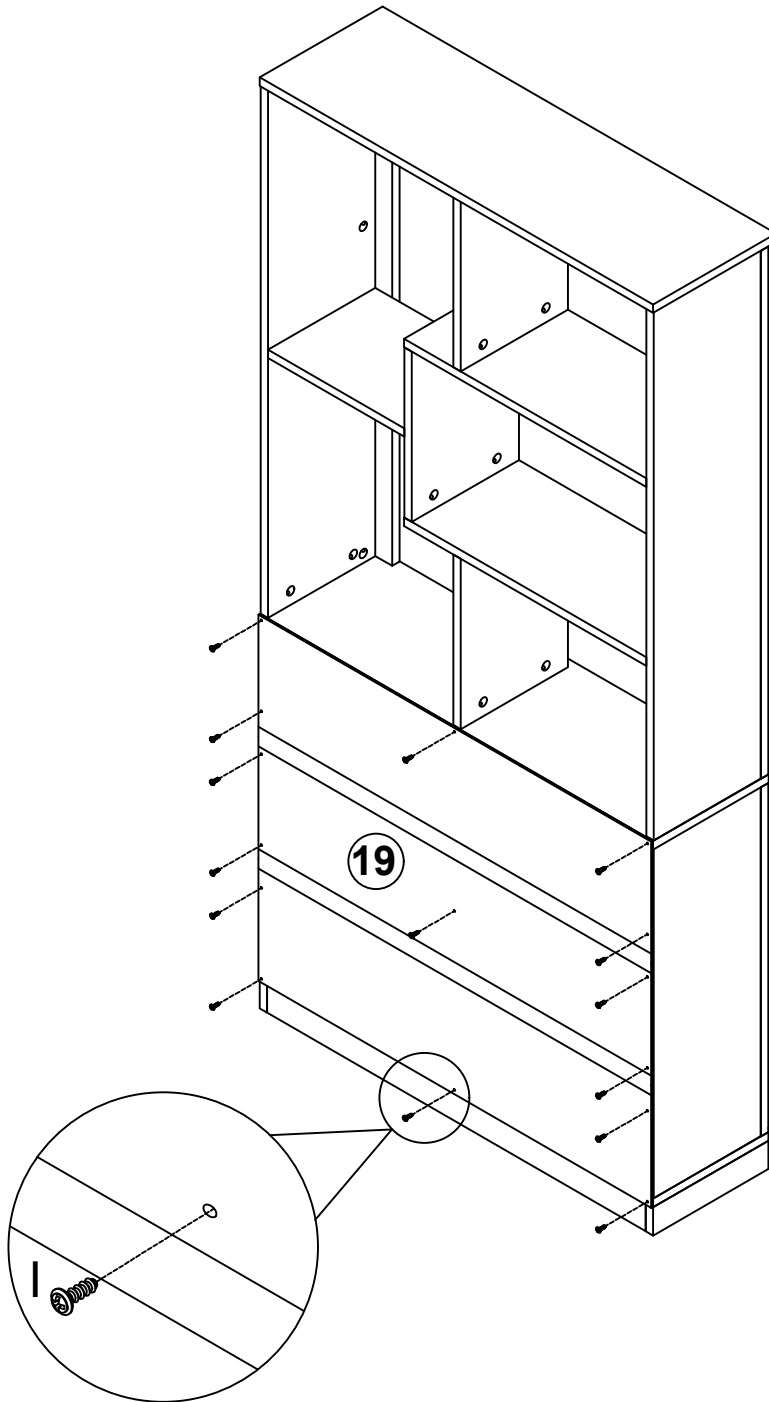

## STEP 27

I:  15PCS



# ASSEMBLY INSTRUCTION

## STEP 28

E:		6PCS
G:		3PCS

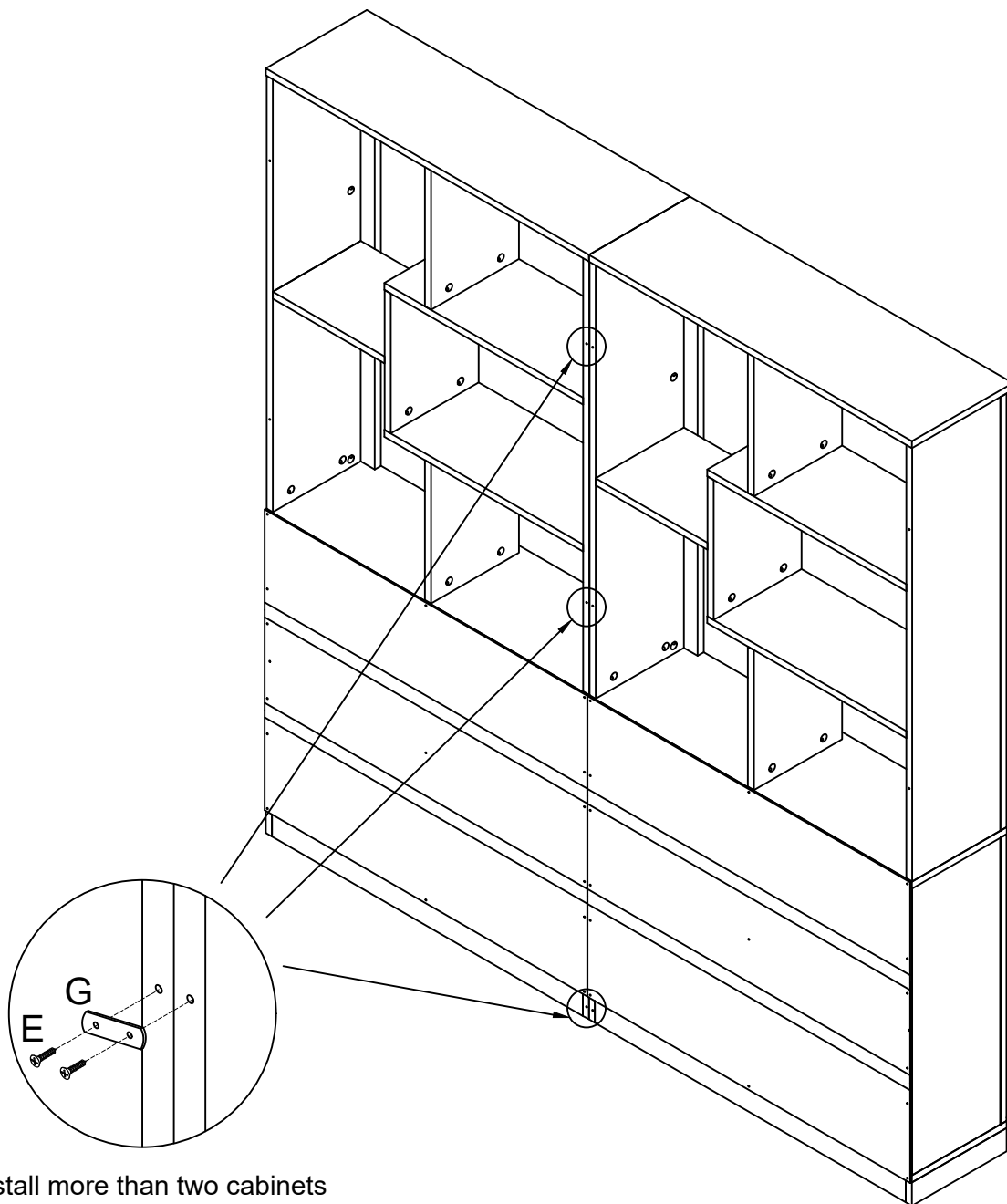

If install more than two cabinets together, fix the connecting iron sheet here.

# ASSEMBLY INSTRUCTION

## STEP 29

H: 2SET

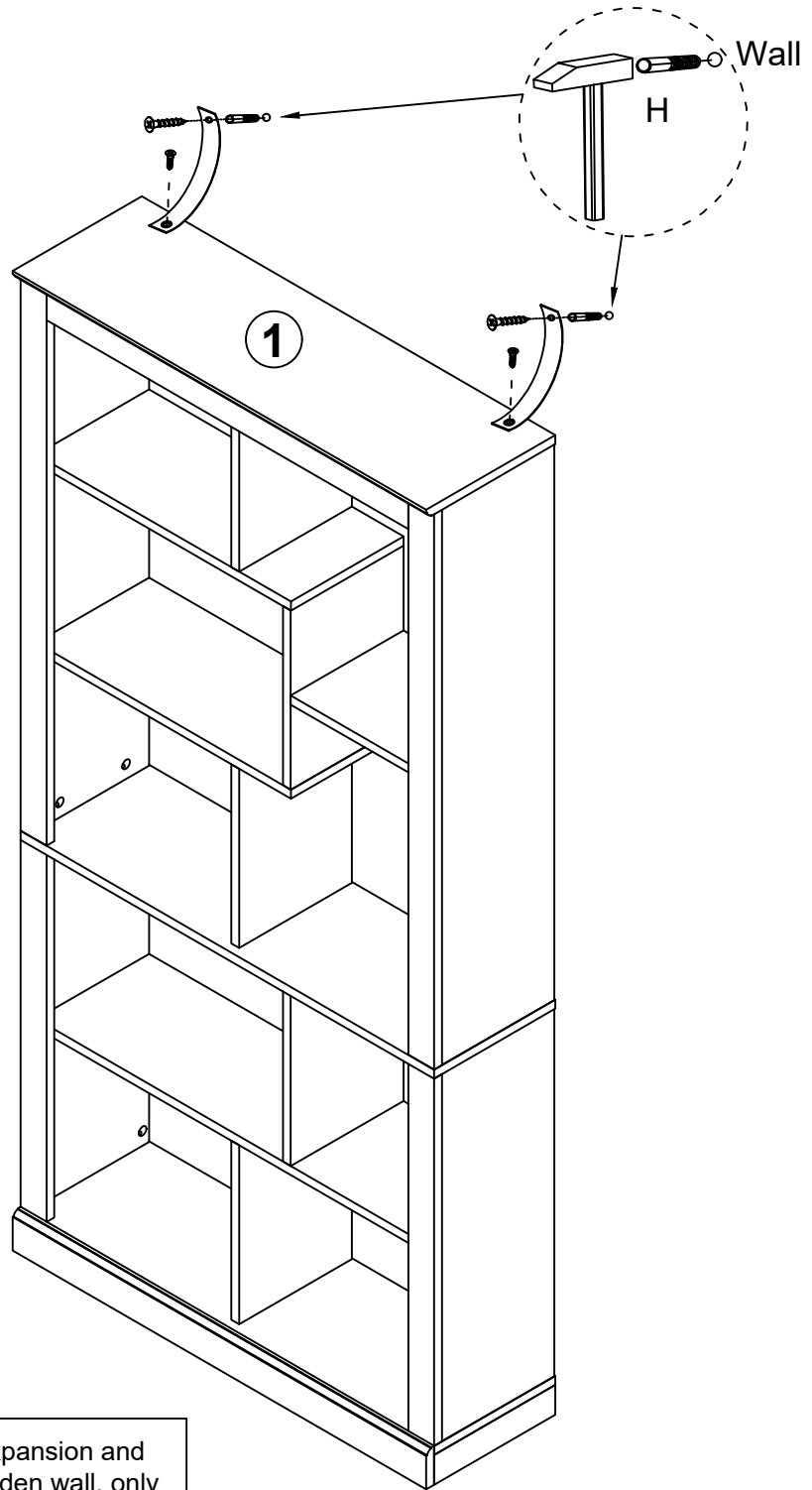
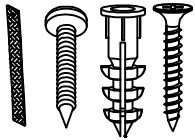

If it is a solid wall, please use expansion and self-tappingscrews, if it is a wooden wall, only use self-tapping screws, please do not overtighten the screws