

ASSEMBLY INSTRUCTIONS

ASSEMBLY TIPS :





1. Remove hardware from box and sort by size
2. Please check to see that all hardware and parts are present prior to start of assembly.
3. Please follow attached instruction in the same sequence as numbered to assure fast & easy assembly.





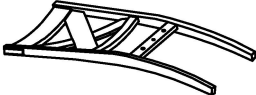

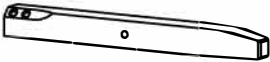

Warning !

1. Don't attempt to repair or modify parts that are broken or defective. Please contact the store immediately.
2. This product is for home use only and not intended for commercial establishment

PARTS IDENTIFICATION

A		CHAIR BACK	1 PC
B		CUSHION SEAT WITH FRAME	1 PC
C		LEFT FRONT LEG	1 PC
D		RIGHT FRONT LEG	1 PC
E		LEFT SIDE STRETCHER	1 PC
F		RIGHT SIDE STRETCHER	1 PC

HARDWARE IDENTIFICATION

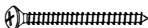
1		LONG BOLT	4 PCS
2		MEDIUM BOLT	2 PCS
3		SHORT BOLT	2 PCS
4		LOCK WASHER	8 PCS
5		FLAT WASHER	8 PCS
6		ALLEN WRENCH	1 PC
7		SCREW	4 PCS

NOTE : QUANTITIES SHOWN ARE FOR ONE CHAIR

ASSEMBLY INSTRUCTIONS

STEP 1

Align and fasten cushion seat with frame (B) to bottom rail of chair back (A) using short bolt (3), lock washer (4) and flat washer (5). DO NOT FULLY TIGHTEN AT THIS STEP.

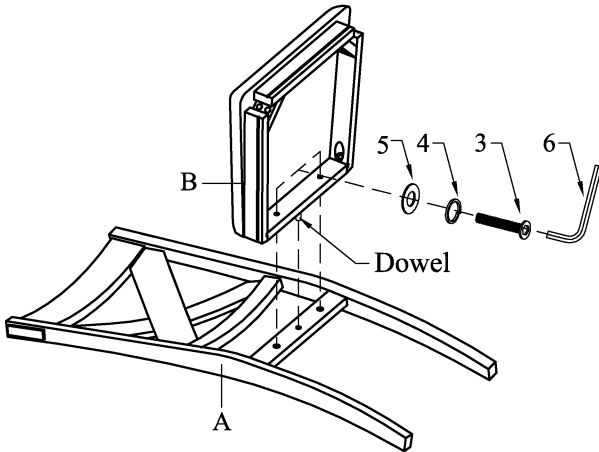

STEP 2

Align and fasten cushion seat with frame (B) to chair back leg (A) using medium bolt (2), lock washer (4) and flat washer (5). THEN FULLY TIGHTEN ALL THE BOLTS AT STEP 1 AND 2 WITH ALLEN WRENCH (6).

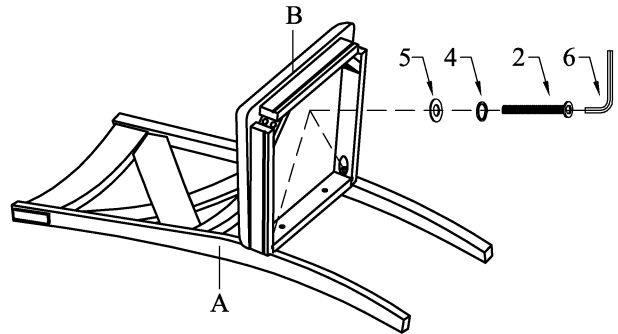

STEP 3

3.1 Align and insert left (E) and right (F) side stretcher to chair back leg (A) and left (C) and right (D) front leg.
3.2 Align and fasten left (C) and right (D) front leg to cushion seat with frame (B) using long bolt (1), lock washer (4) and flat washer (5) and fully tighten with Allen wrench (6).

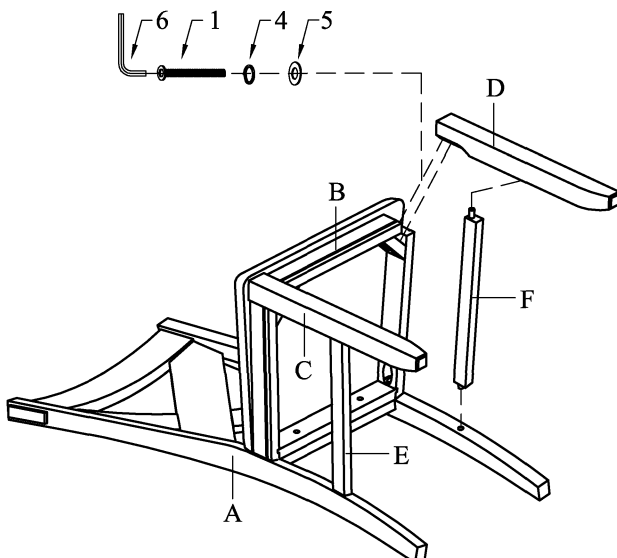

STEP 4

Insert screw (7) into bottom of stretchers and fully tighten with screw driver (NOT INCLUDED).

