



A

B1

100006

	 SX 4.5°50 RW	
--	------------------	--

B2

100016

517710

216 x 59 cm

100016	517710	11mm	

B3

100005

517710

216 x 58 cm

517710	100005	16mm	

B4

100016

517710

216 x 62 cm

517710	100016	11mm	

B5

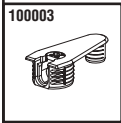
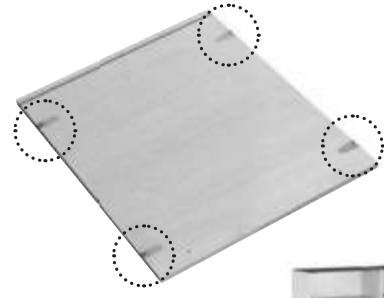
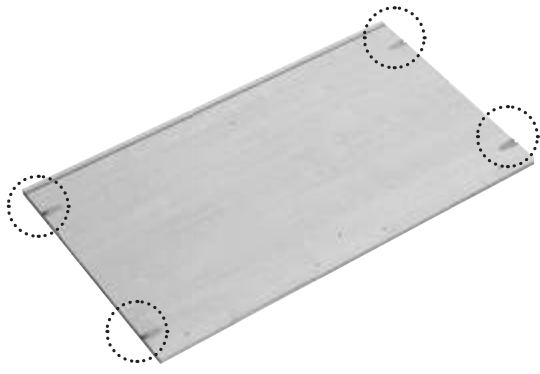
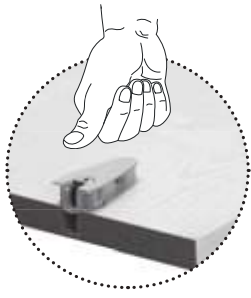



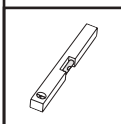
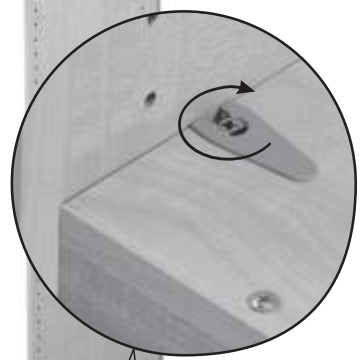
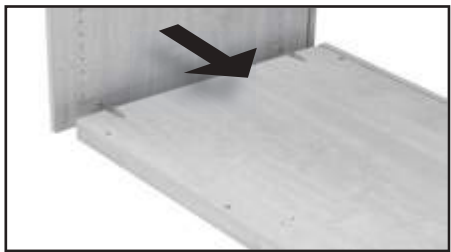

B6



B7





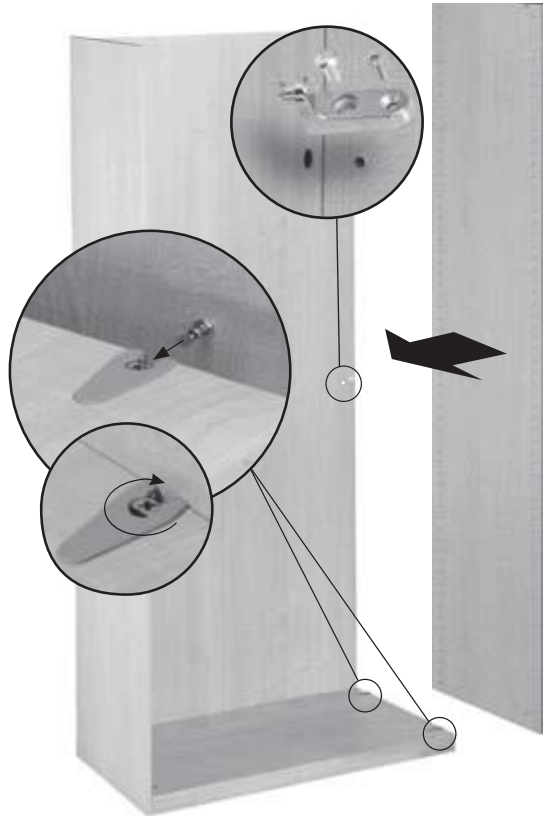
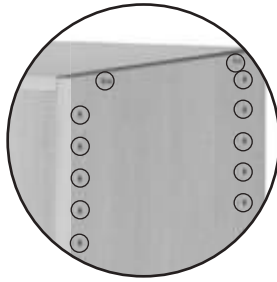

- 
- 165150**

SX 3.5*16FLAKO
- 165160**

6.3*12
- 527690**

15/42

A

B8



- 165150

SX 3.5*16FLAKO
 - 165160

6.3*12
 - 527690

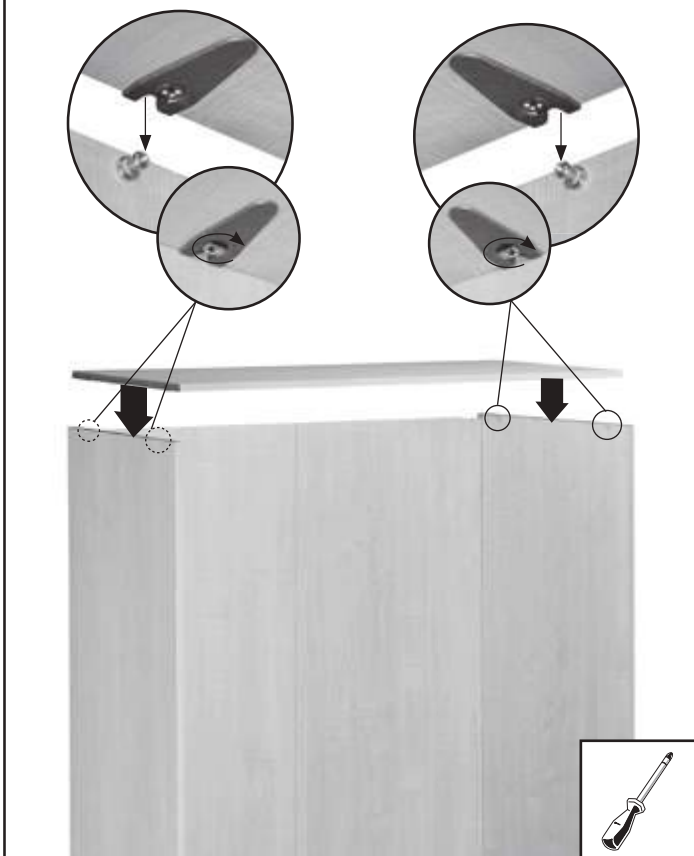
15/42
- 

A

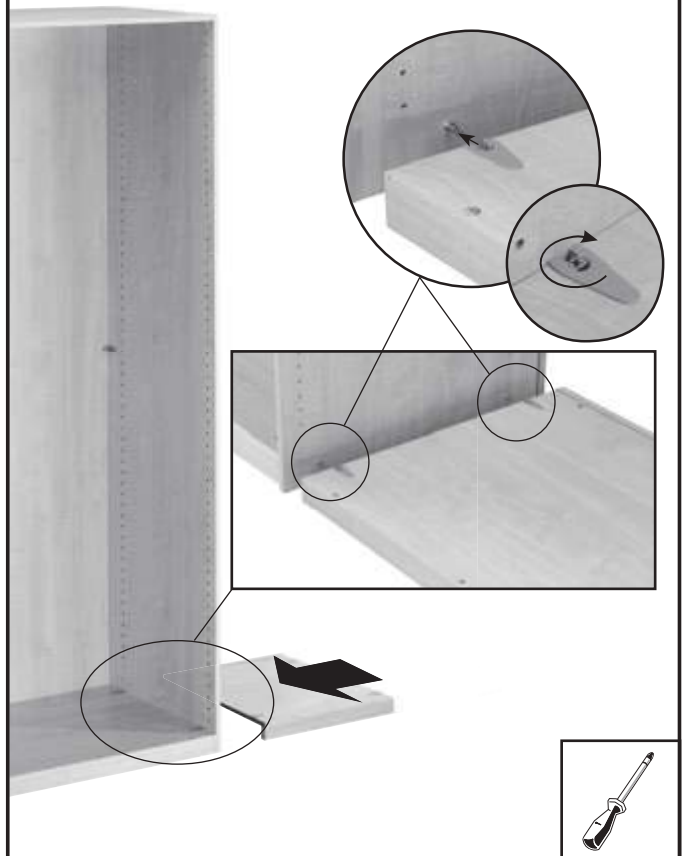
B9



B10



B11

165150 SX 3.5*16FLAKO	165160 6.3*12	527690 15/42
---------------------------------	-------------------------	------------------------

B12

527690 15/42

B13

527690 15/42

B14

517710

B15

100001	100002 M6*25	100003	100005 16mm	100006 SX 4.5*50 RW	100016 11mm	100020
---------------	------------------------	---------------	-----------------------	-------------------------------	-----------------------	---------------

100001	100002 M6*25	100003	100005 16mm	100006 SX 4.5*50 RW	100016 11mm	100020
100021	101043	165150 SX 3.5*16FLAKO	165160 6.3*12	517710	527690 15/42	



B

C1

100006

2 x

200

	100006	100003
	SX 4.5*50 RW	

C2

100016

517710

216 x 59 cm

200

100016	517710		
11mm			

C3

100005

517710

216 x 58 cm

200

517710	100005		
	16mm		

C4

100016

517710

216 x 62 cm

200

517710	100016		
	11mm		

C5

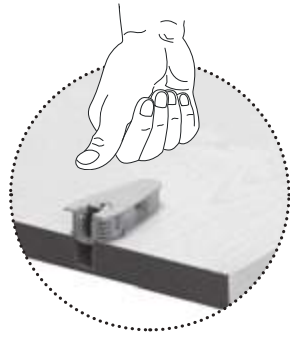

100003

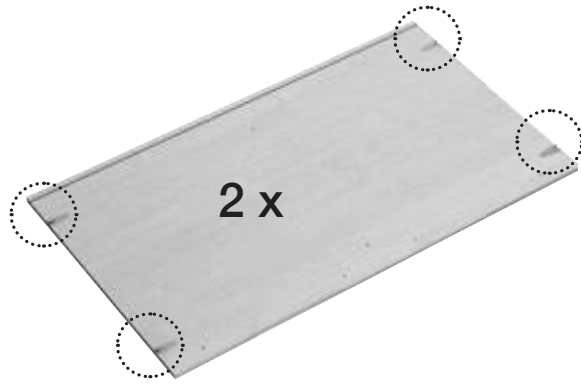



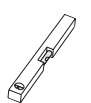
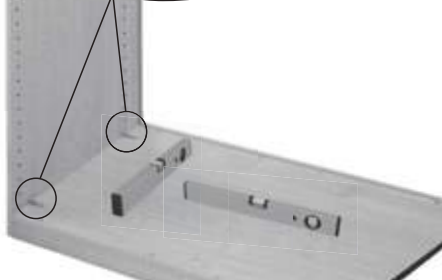
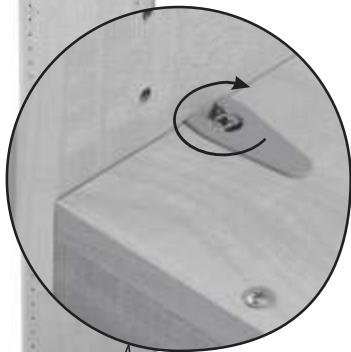
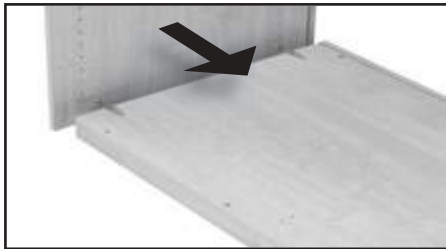

C6







C7

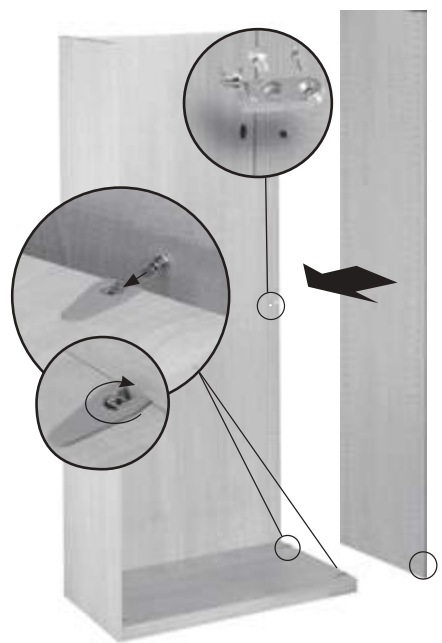
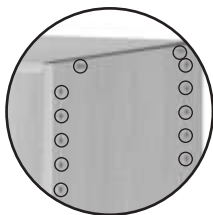

- 
- 165150**

SX 3.5*16FLAKO
- 165160**

6.3*12
- 527690**

15/42

C8



- 165150**

SX 3.5*16FLAKO
- 165160**

6.3*12
- 527690**

15/42
- 

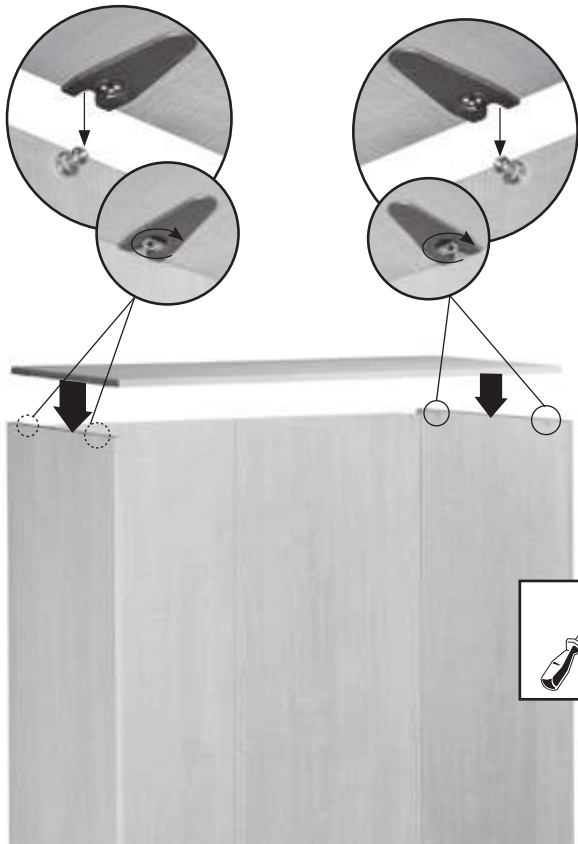
B

B

C9



C10

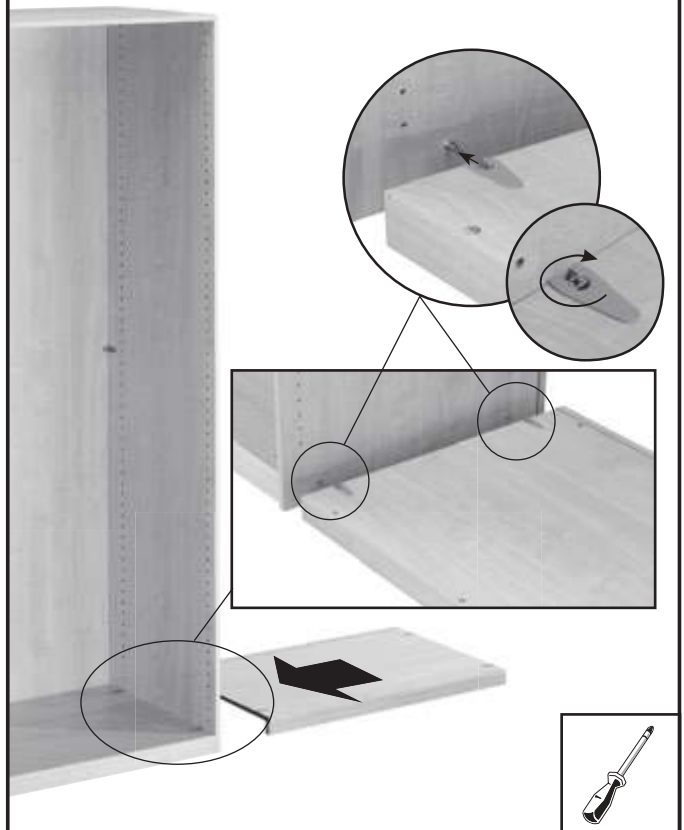

C11

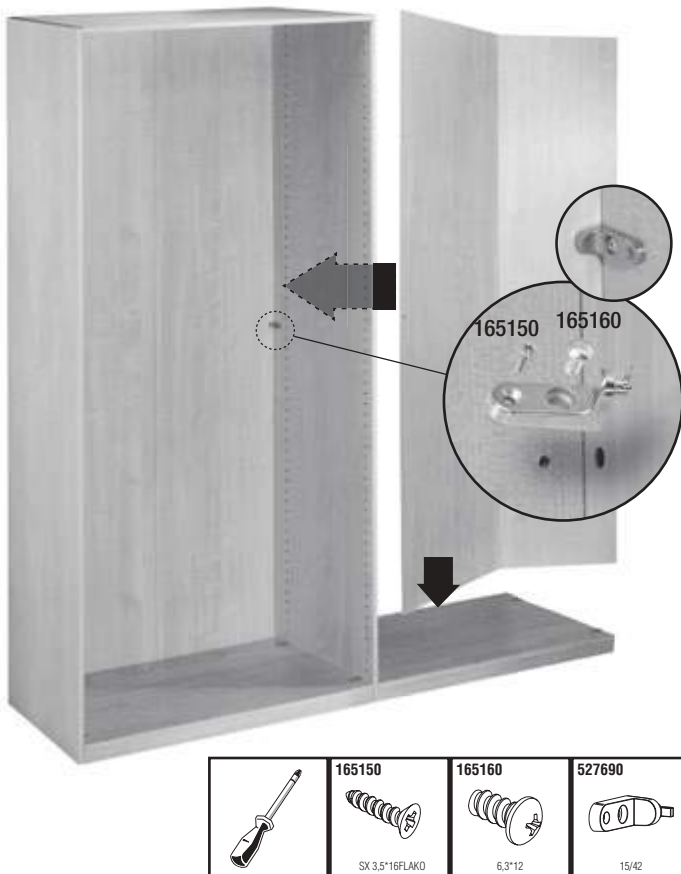

C12

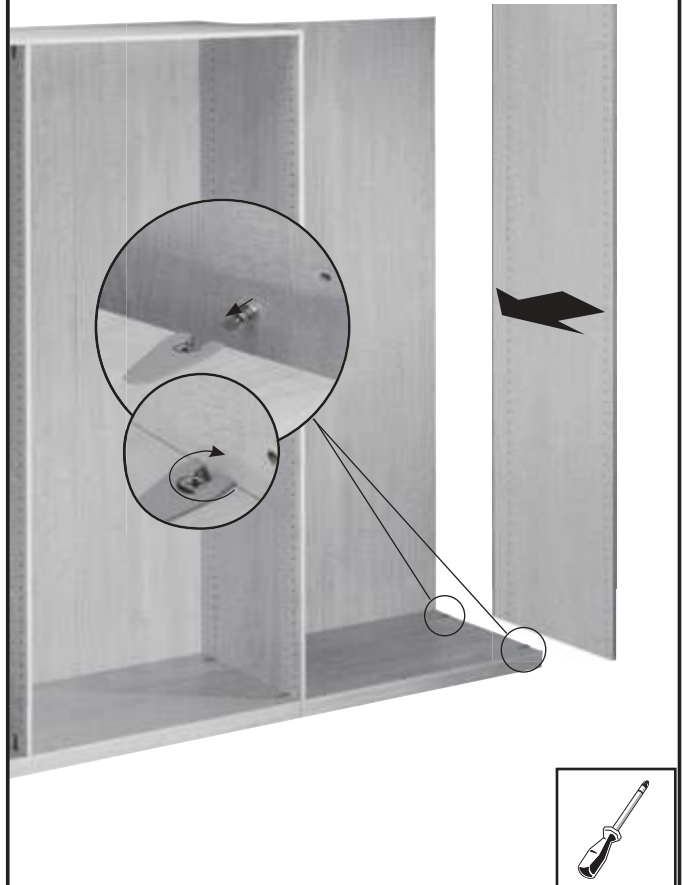

C13

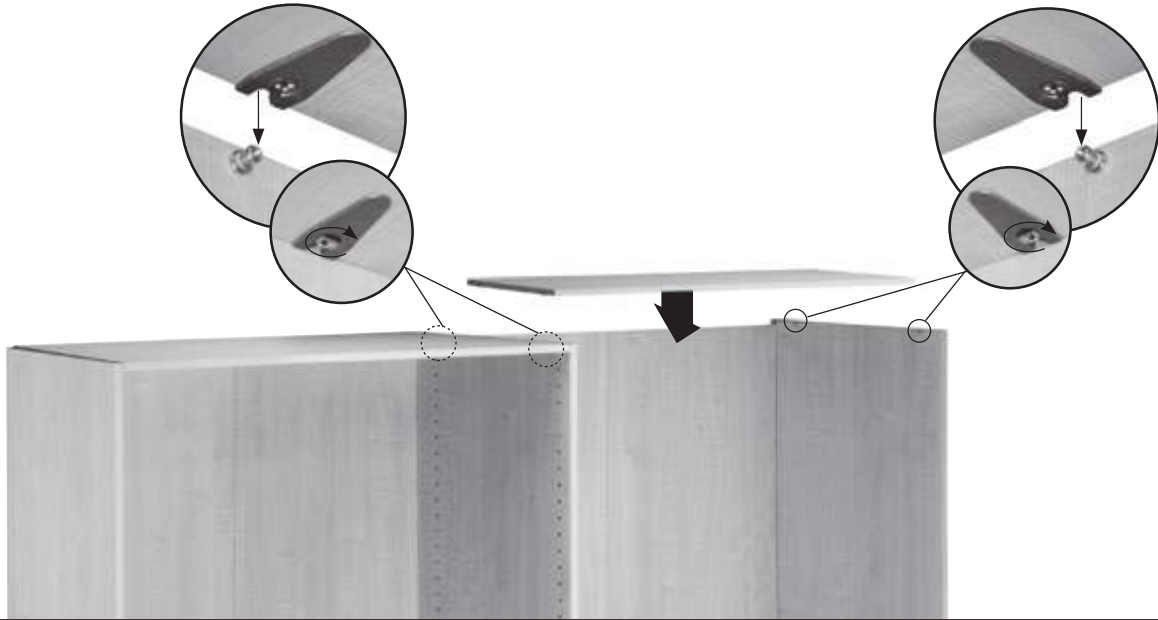

C14

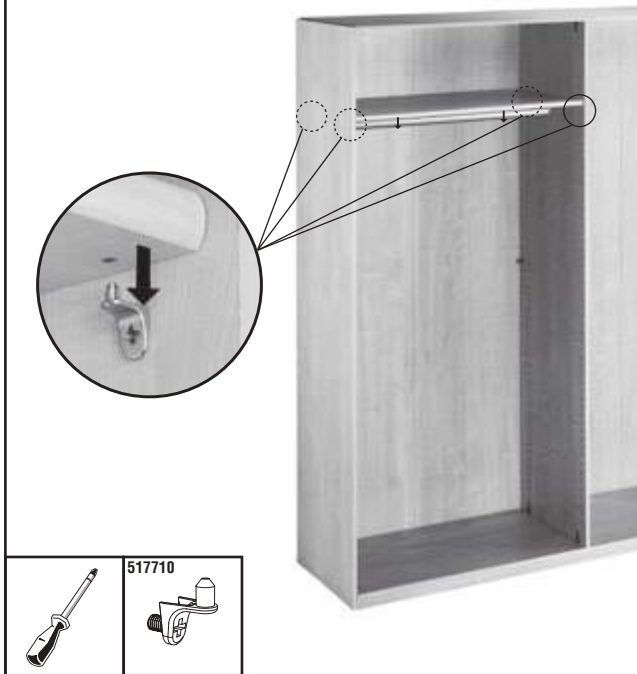

C15

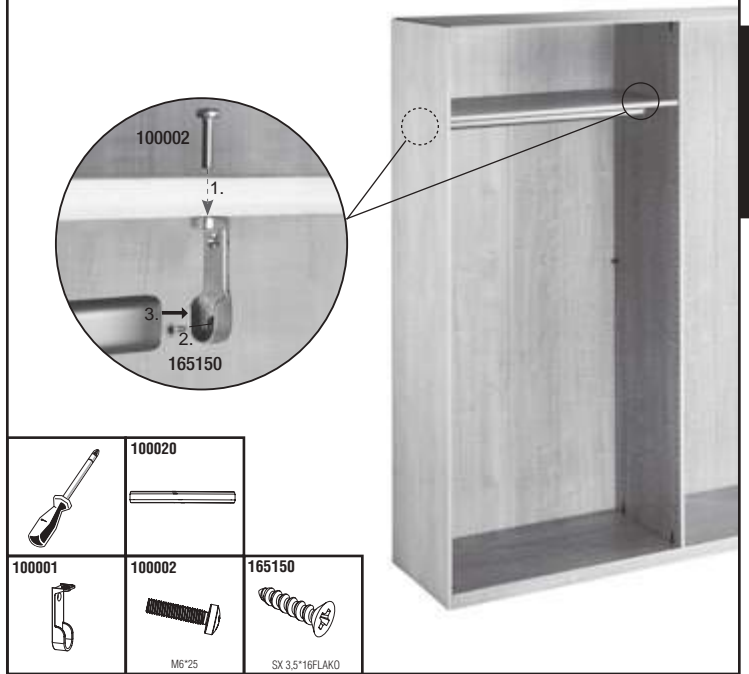

100001	100002	100003	100005	100006	100016	100020
	 M6*25		 16mm	 SX 4.5*50 RW	 11mm	
100021	101043	165150	165160	517710	527690	
		 SX 3.5*16FLAKO	 6.3*12		 15/42	

B



D1

100006

2 x

250

100006
SX 4.5*50 RW

100003

D2

100016

517710

216 x 59 cm

250

100016

517710

11mm

D3

100005

517710

216 x 58 cm

250

517710

100005
16mm

D4

100016

517710

216 x 62 cm

250

517710

100016
11mm

C

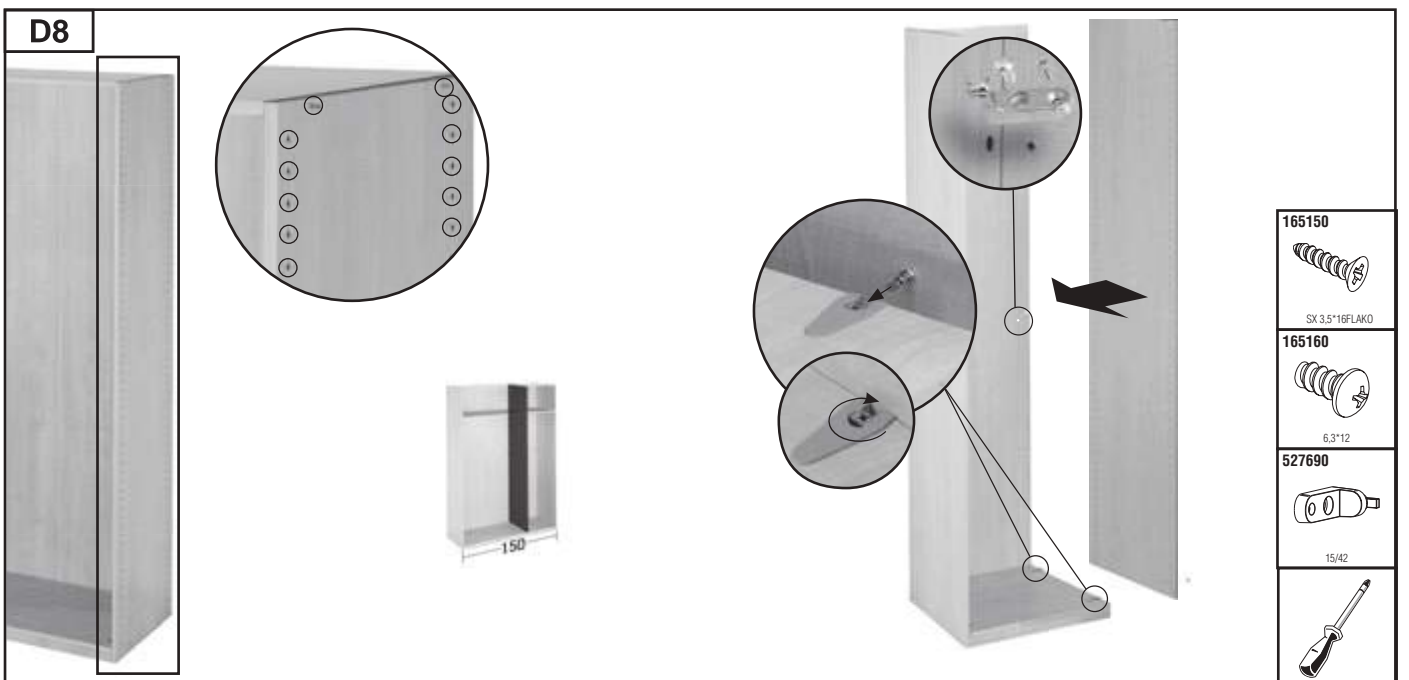
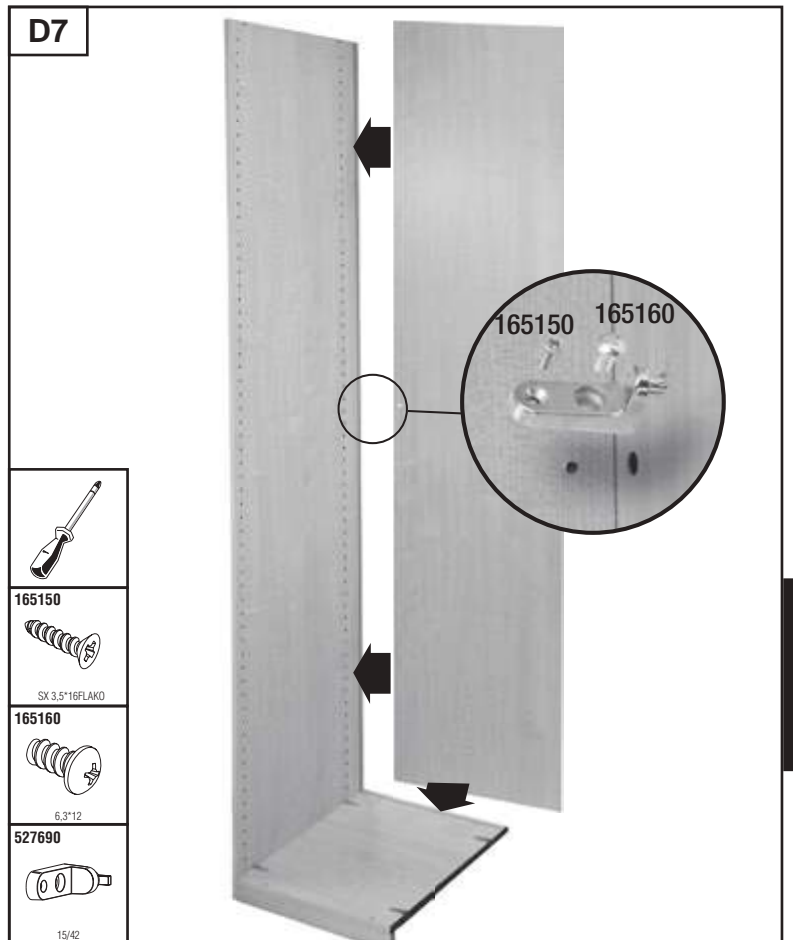
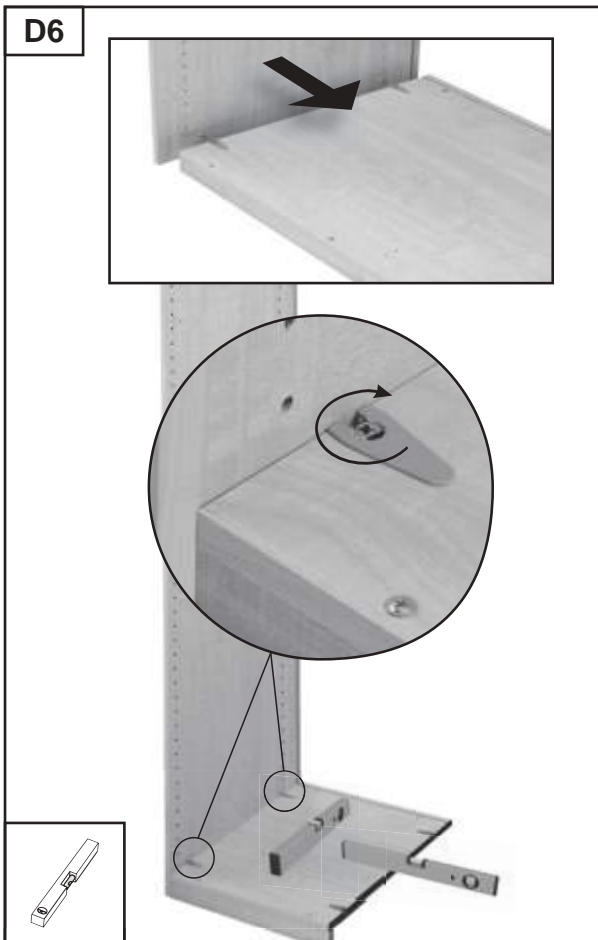
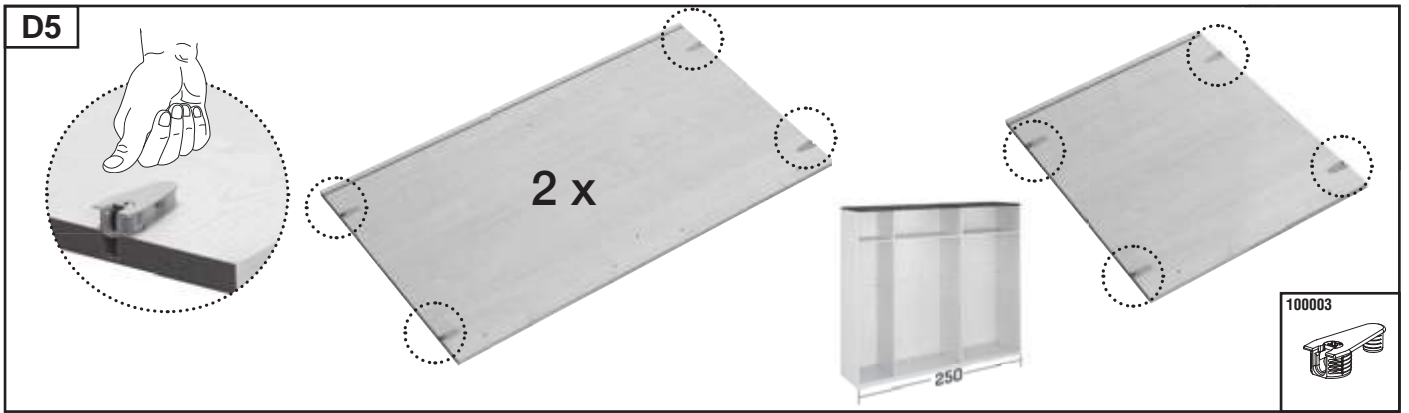

C

D9

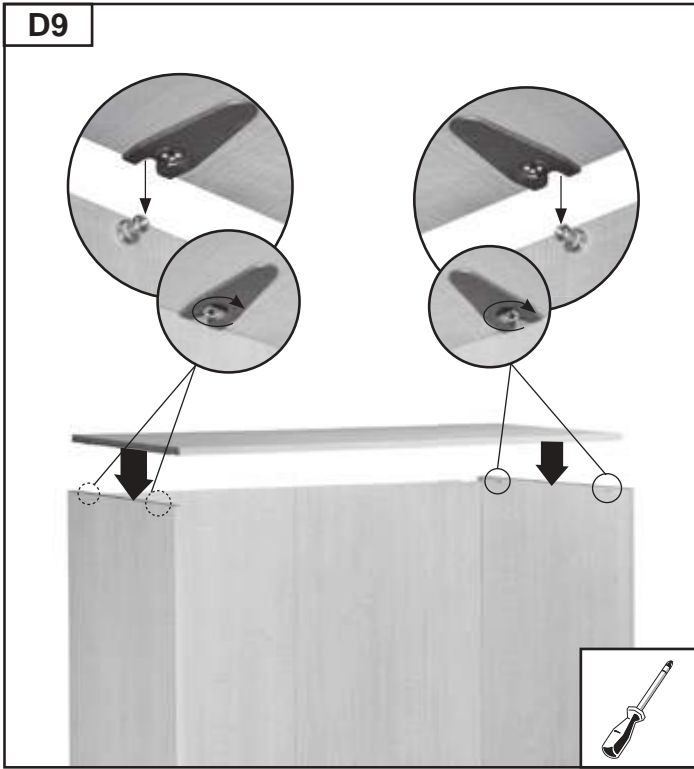

D10

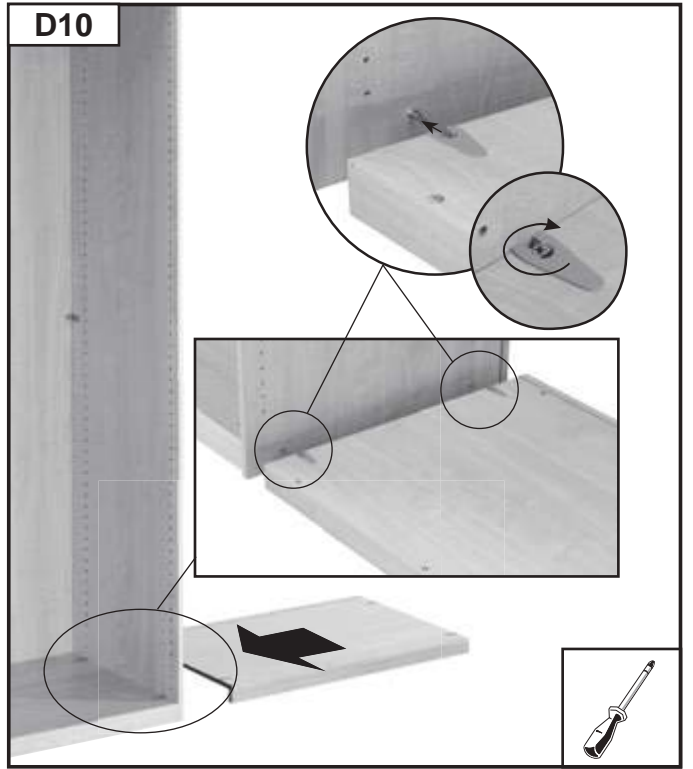

D11

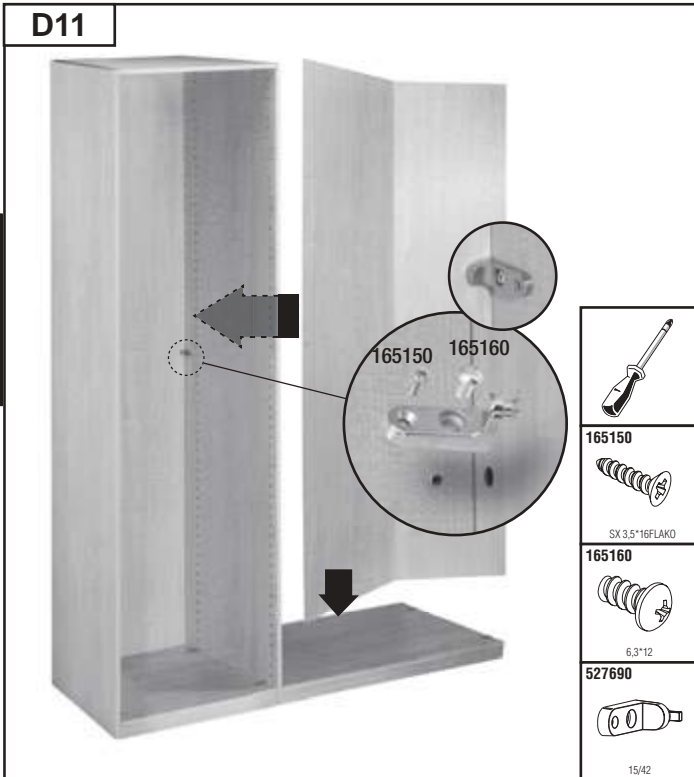

D12

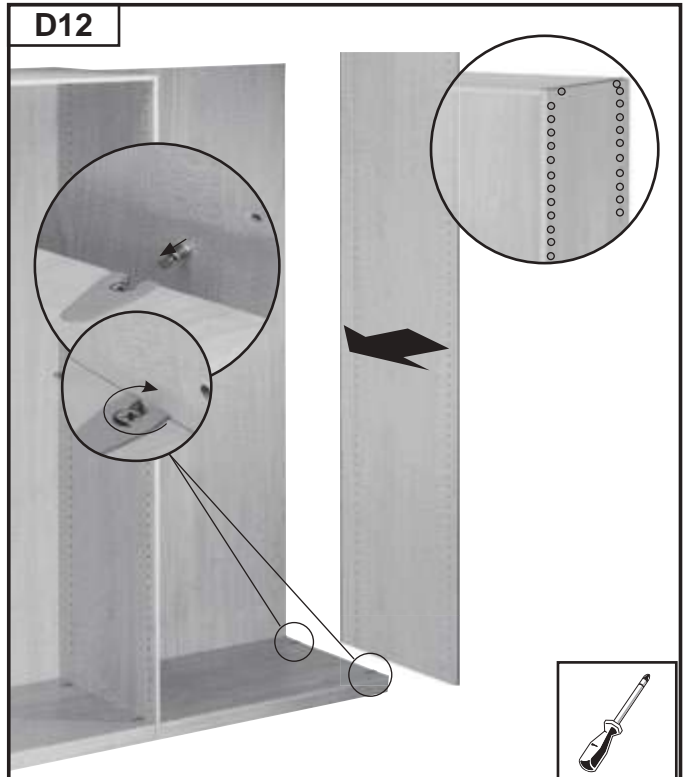

D13

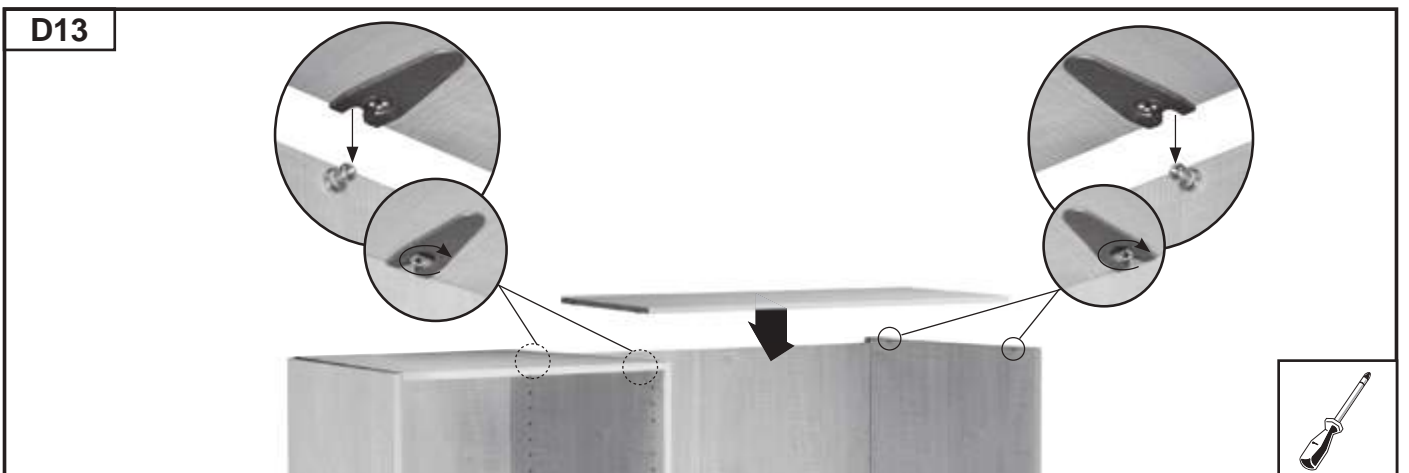

C

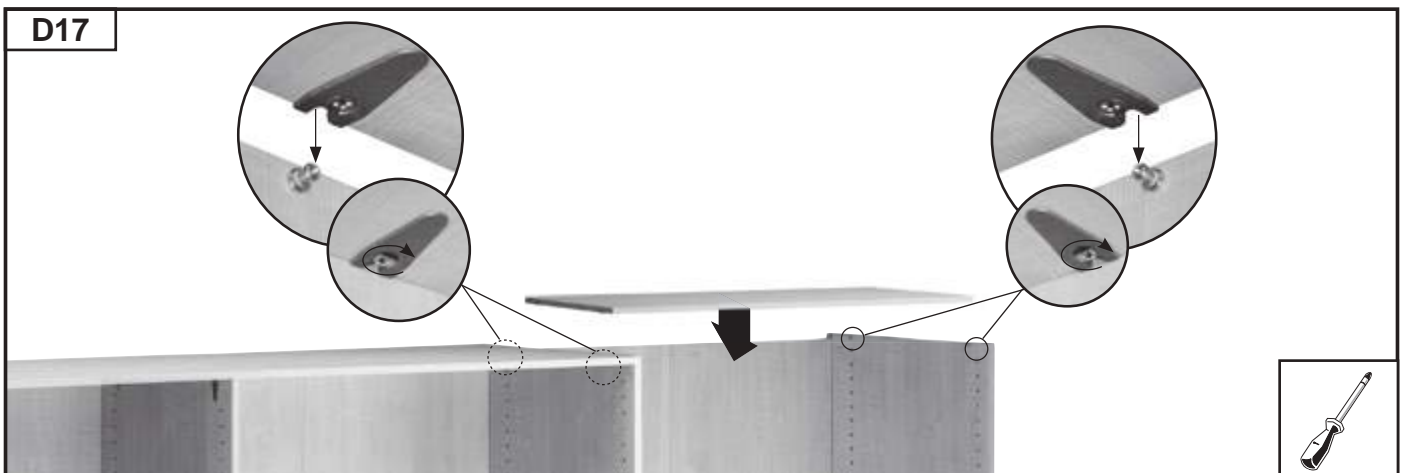
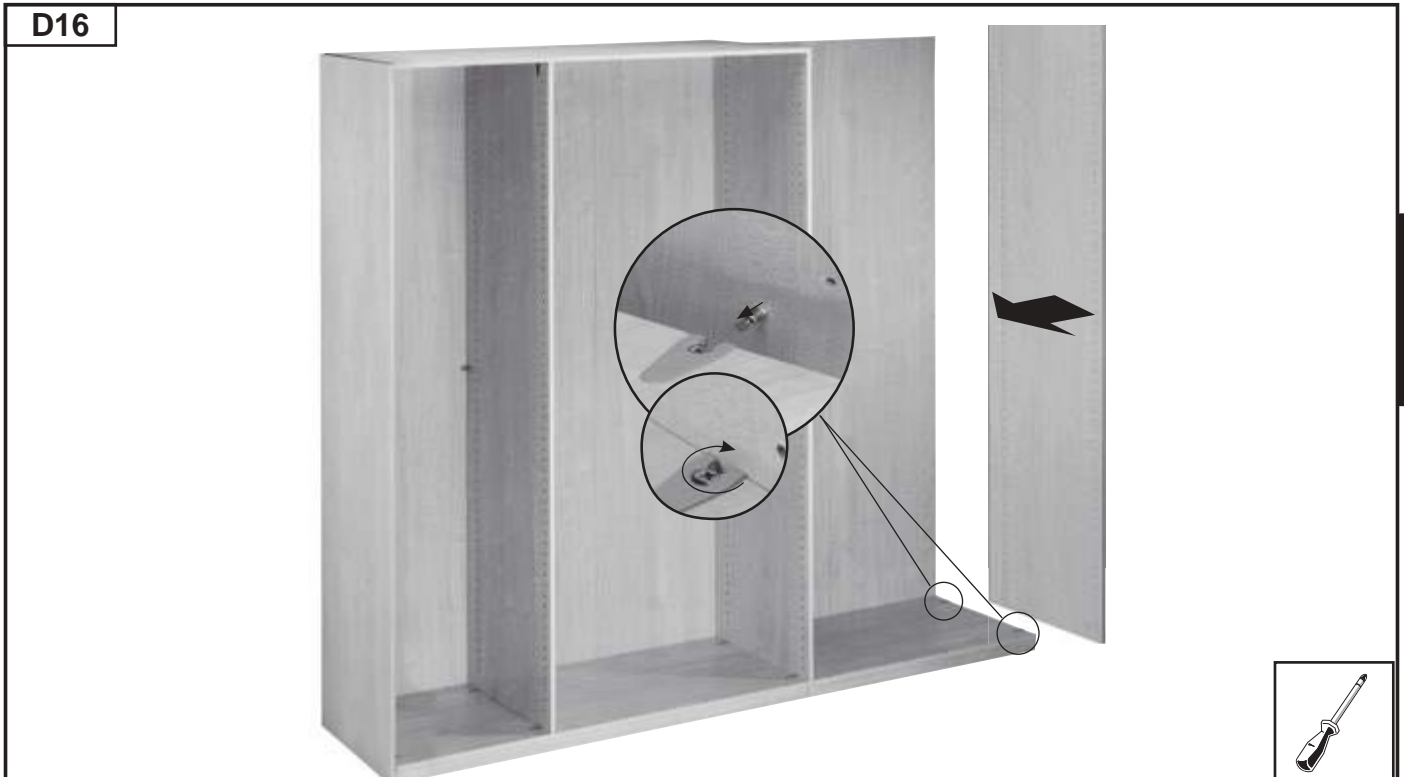
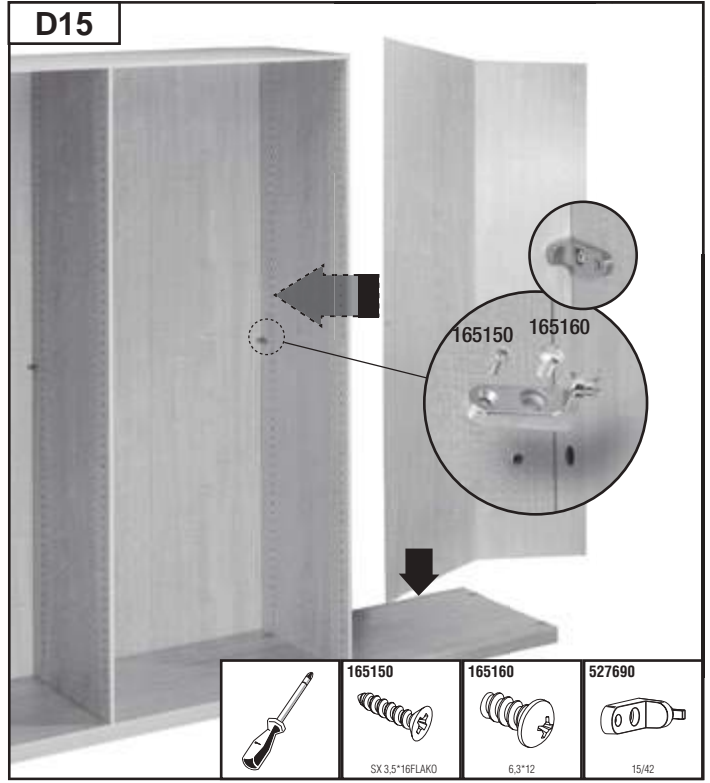
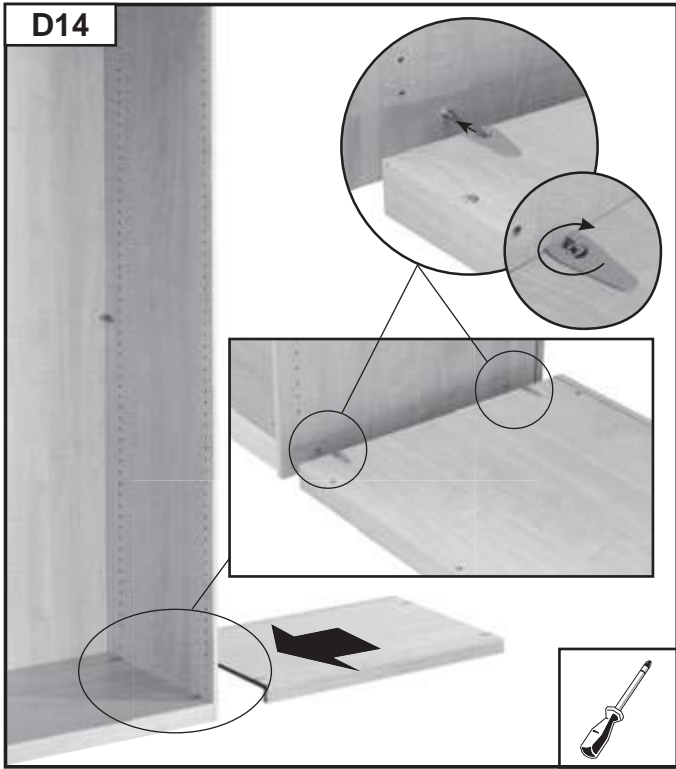

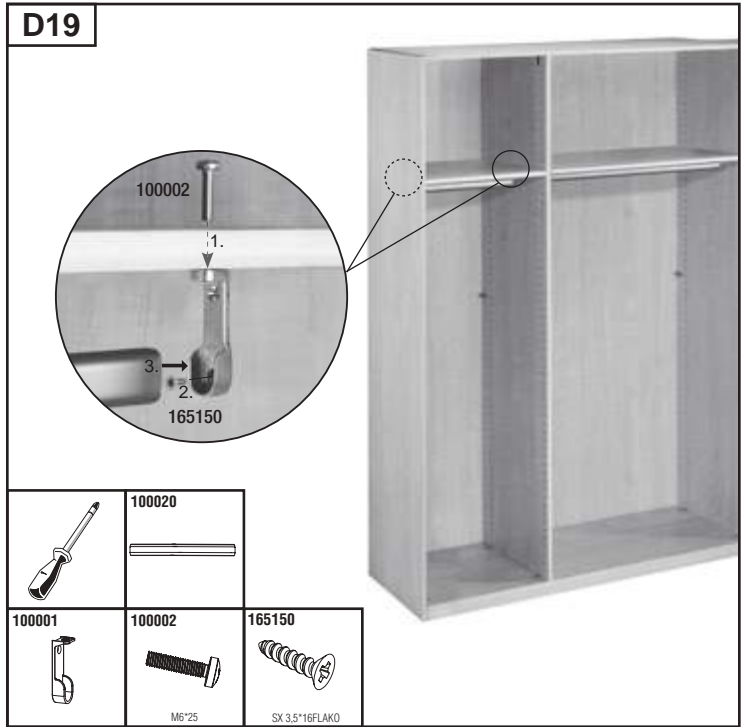
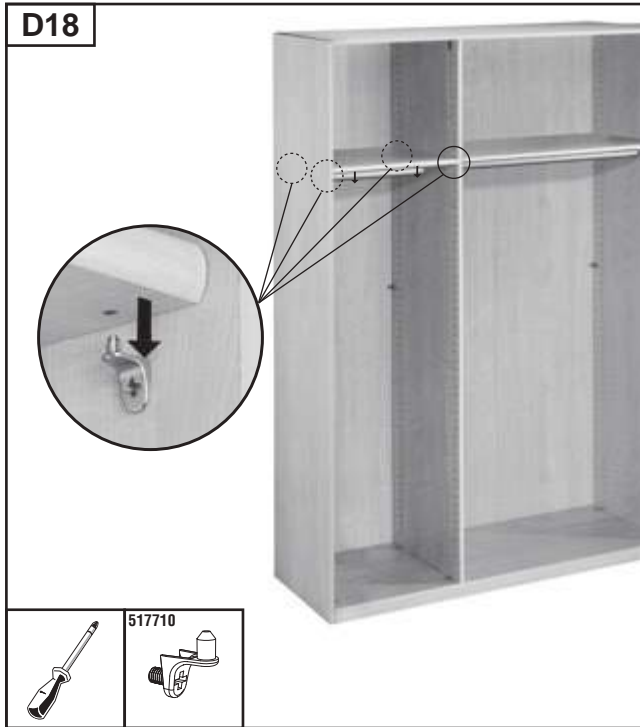

100001	100002	100003	100005	100006	100016	100020
	M6*25		16mm	SX 4.5*50 RW	11mm	
100021	101043	165150	165160	517710	527690	
		SX 3.5*16FLAKO	6.3*12		15/42	



D1

100006

2 x

2 x

300

100006
SX 4.5*50 RW

100003

D2

100016

517710

216 x 59 cm

600

100016

517710

11mm

D3

100005

517710

216 x 58 cm

300

517710

100005

16mm

D4

100016

517710

216 x 62 cm

300

517710

100016

11mm

D

D5

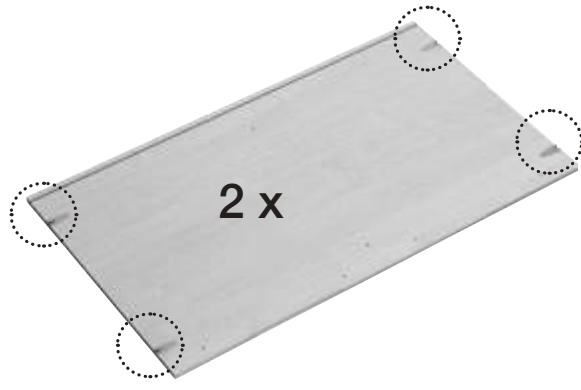
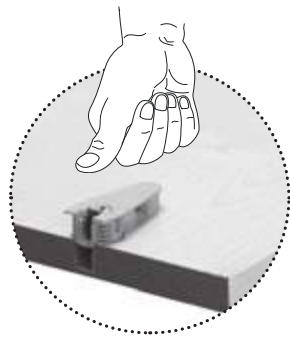

100003





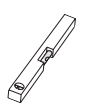
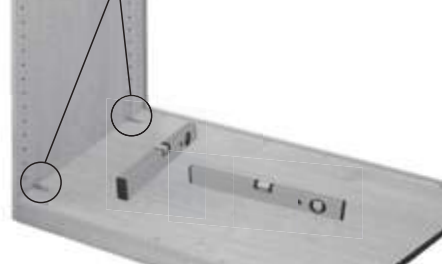
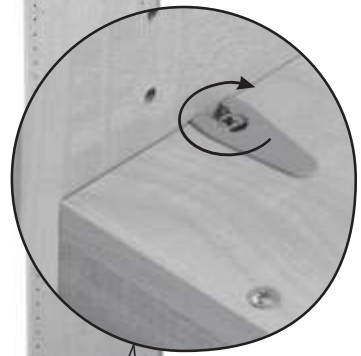
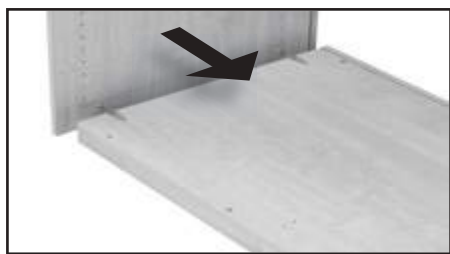

D6

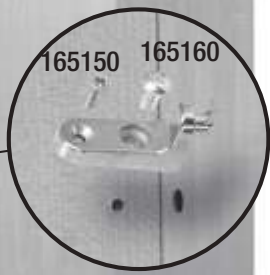

D7





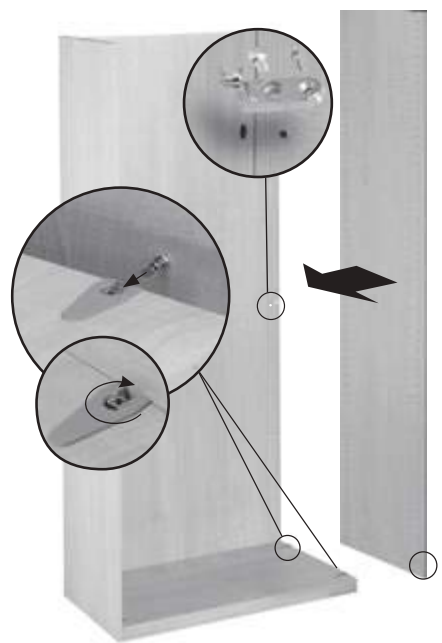
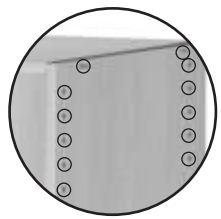

- 
- 165150**

SX 3.5*16FLAKO
- 165160**

6.3*12
- 527690**

15/42

D

D8



- 165150**

SX 3.5*16FLAKO
- 165160**

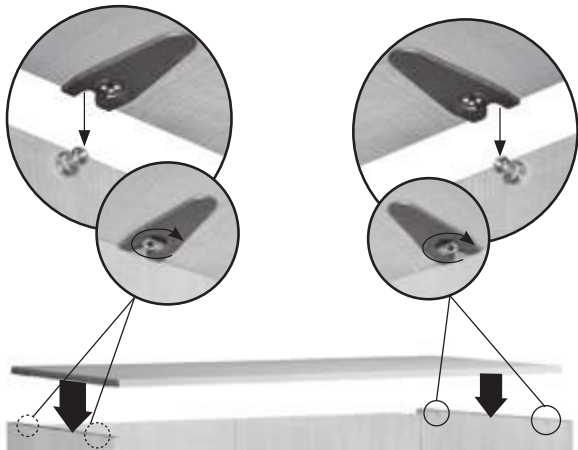
6.3*12
- 527690**

15/42
- 

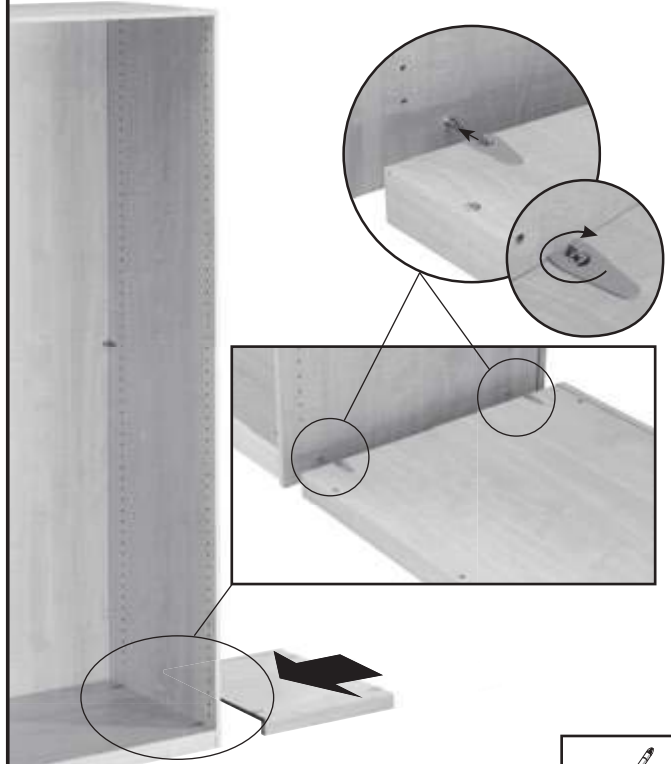
D9



D10



D11

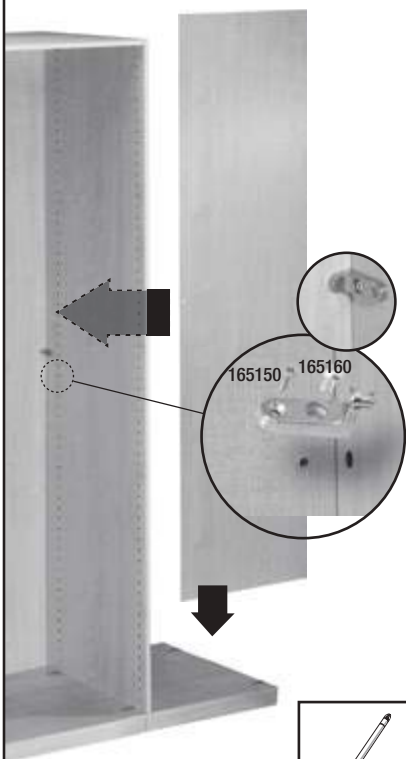

SX 3.5*16FLAKO



6.3*12



15/42

D12

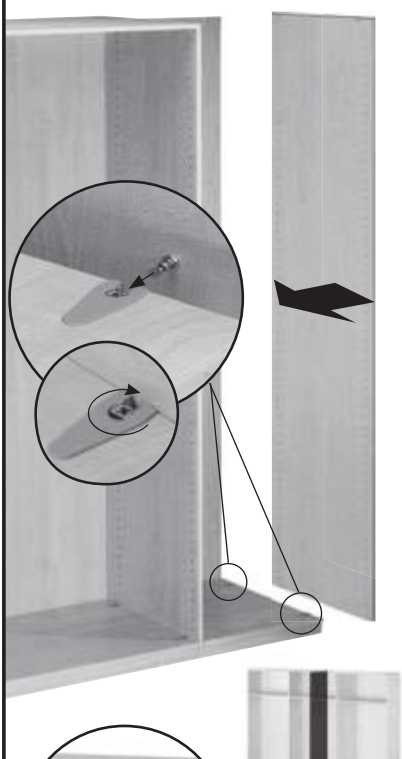

D13

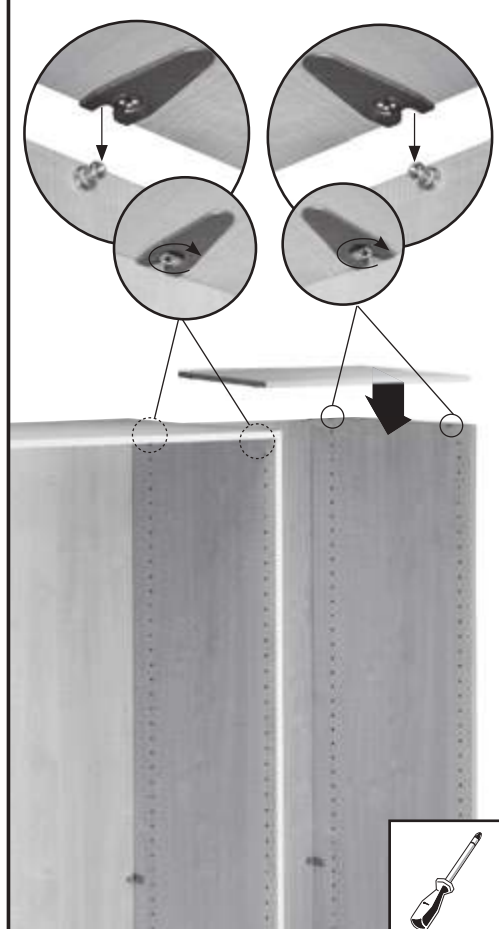



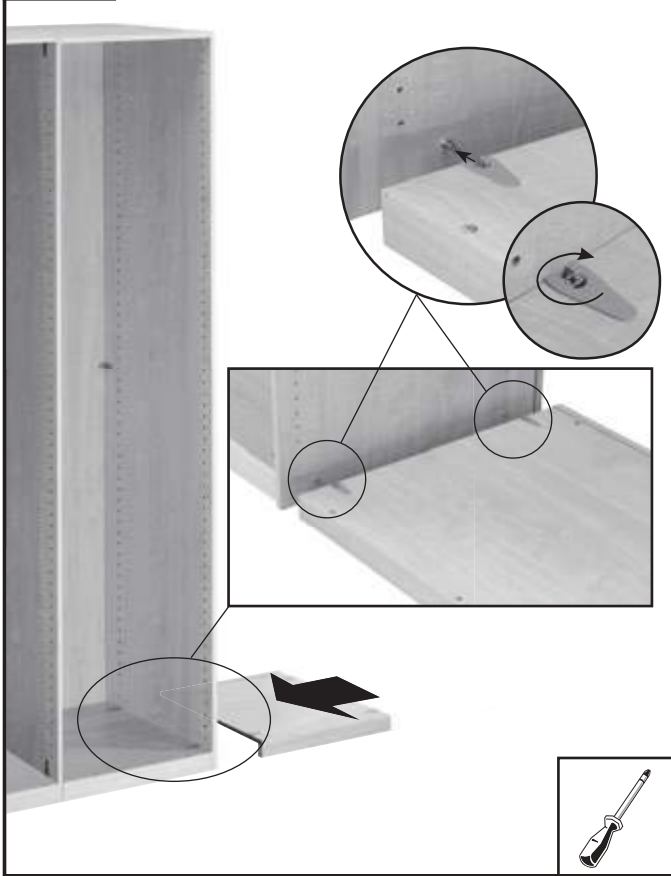

D

D14

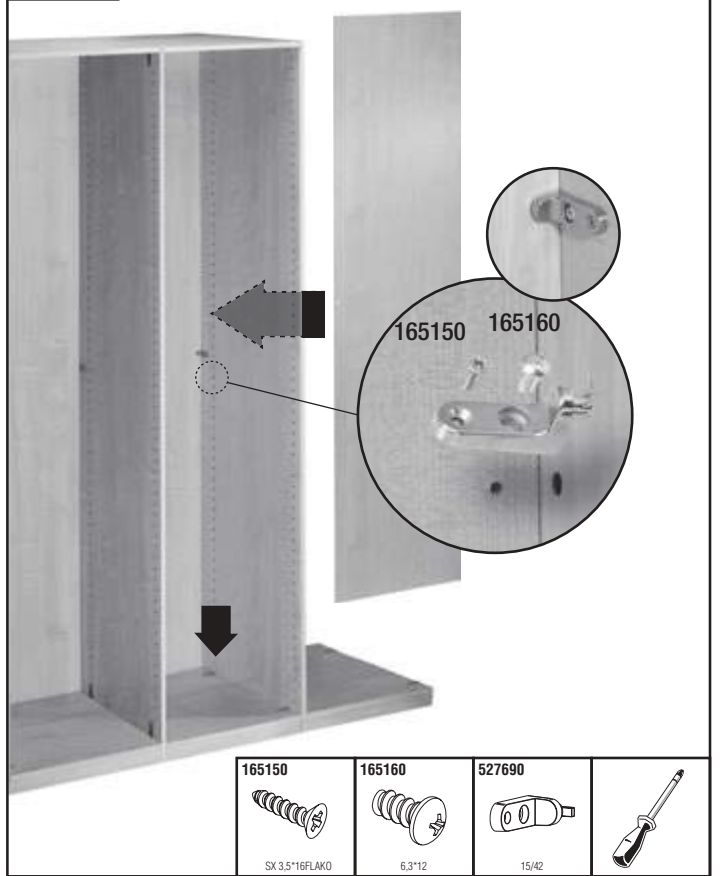

D15



<p>165150</p>  <p>SX 3.5*16FLAKO</p>	<p>165160</p>  <p>6.3*12</p>	<p>527690</p>  <p>15/42</p>	
--	--	---	--

D16



D17

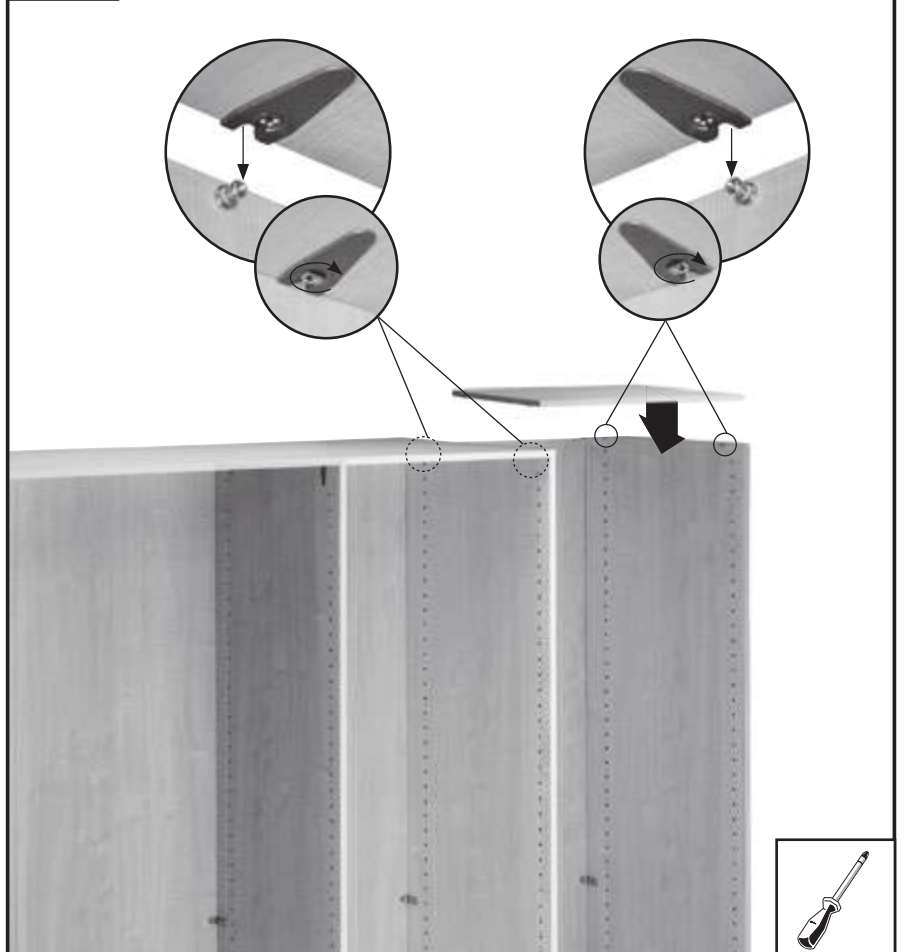

D

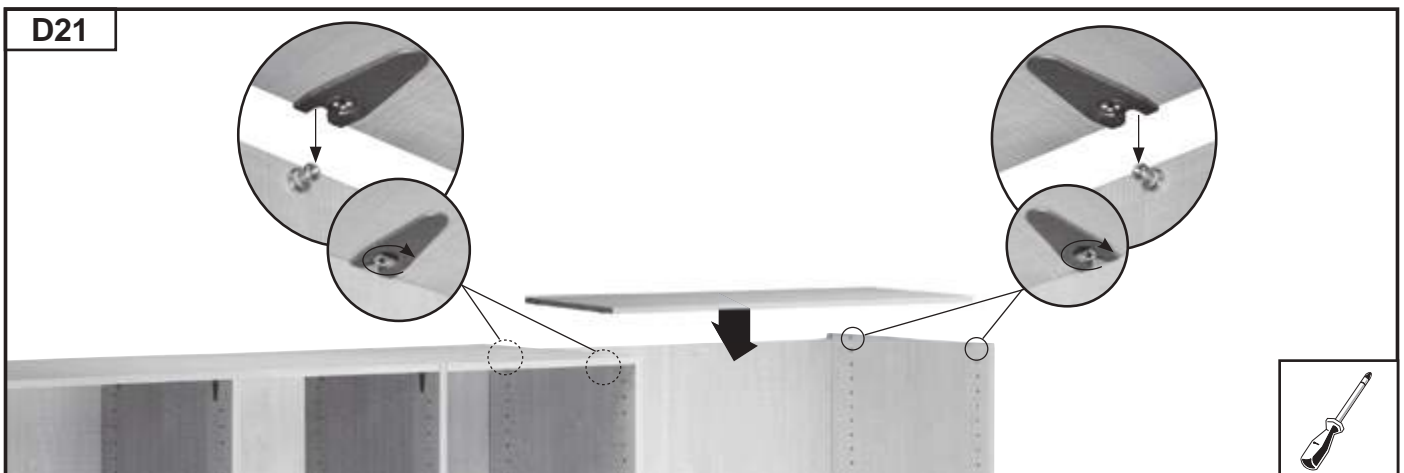
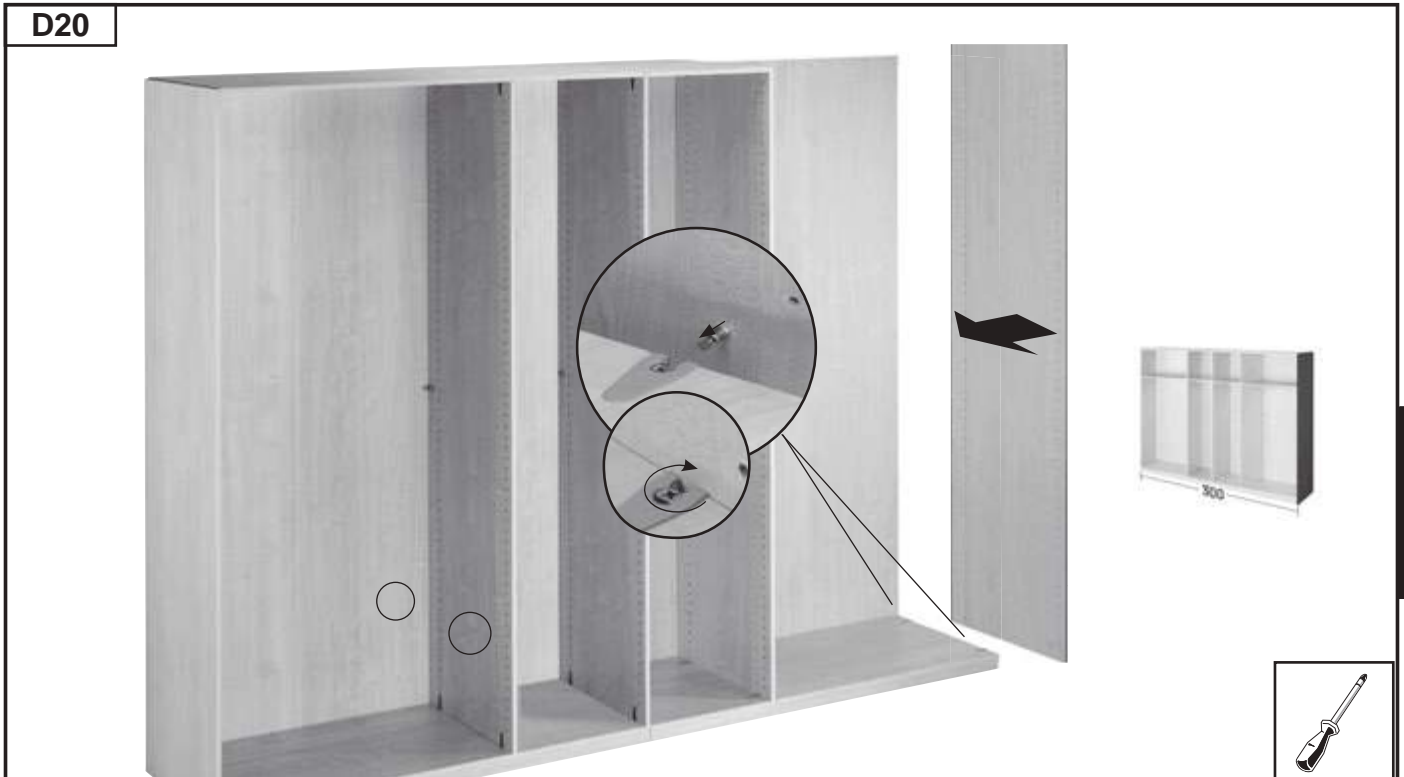
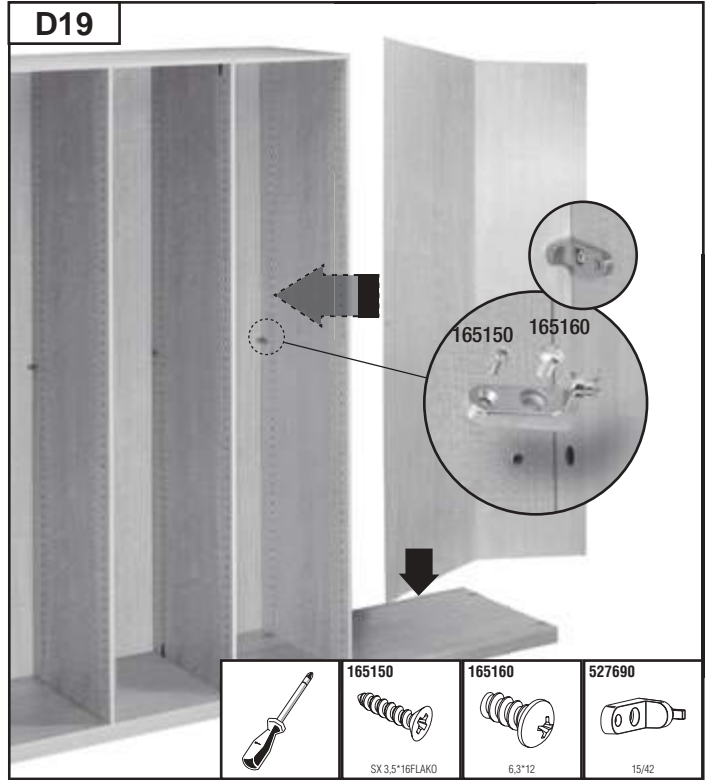
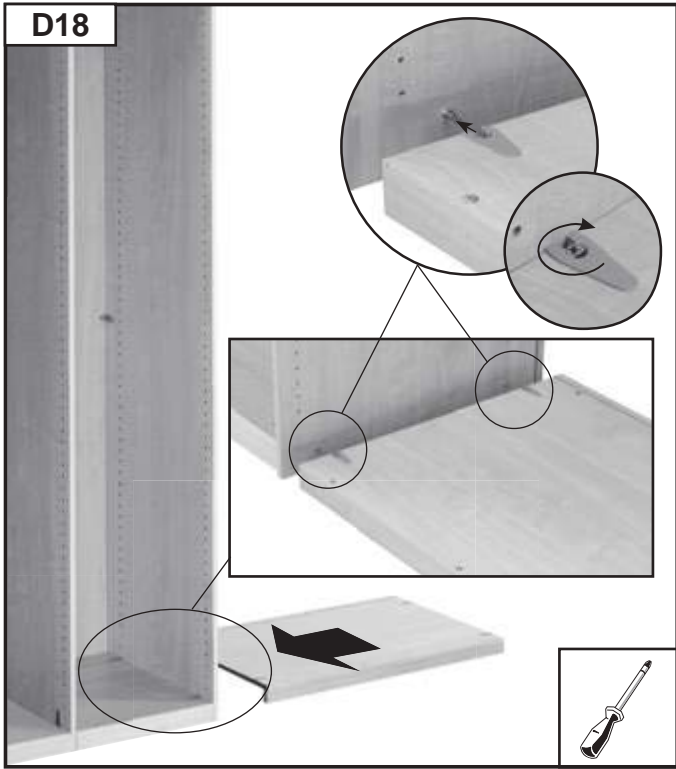

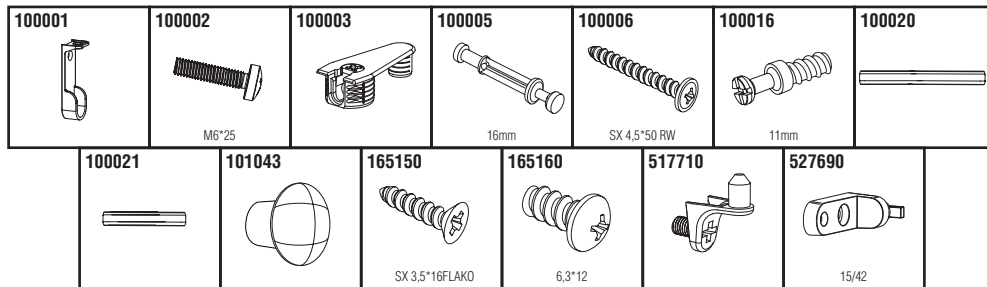
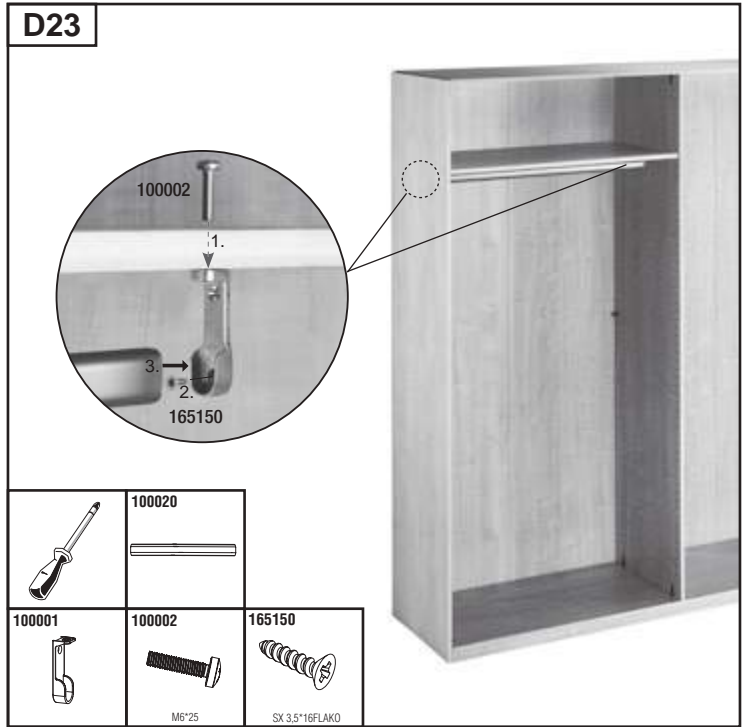
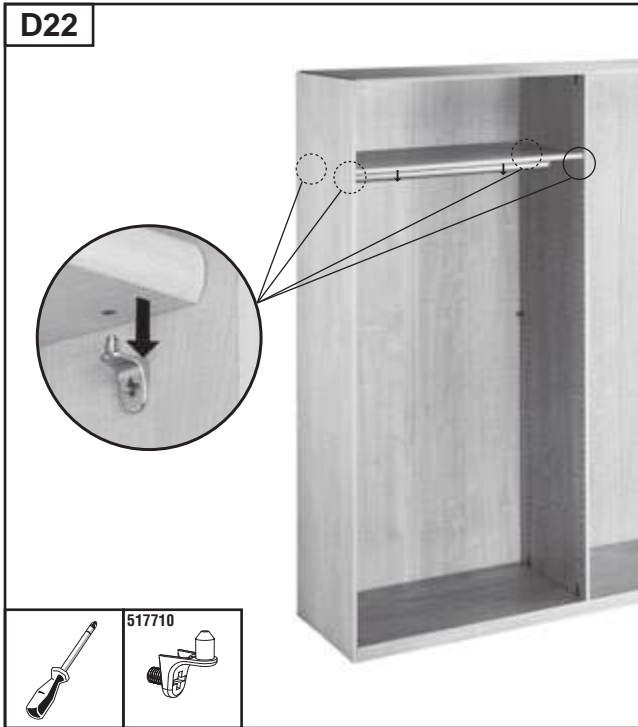

D

1

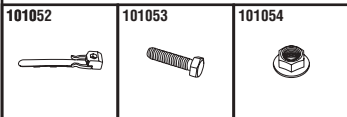

2

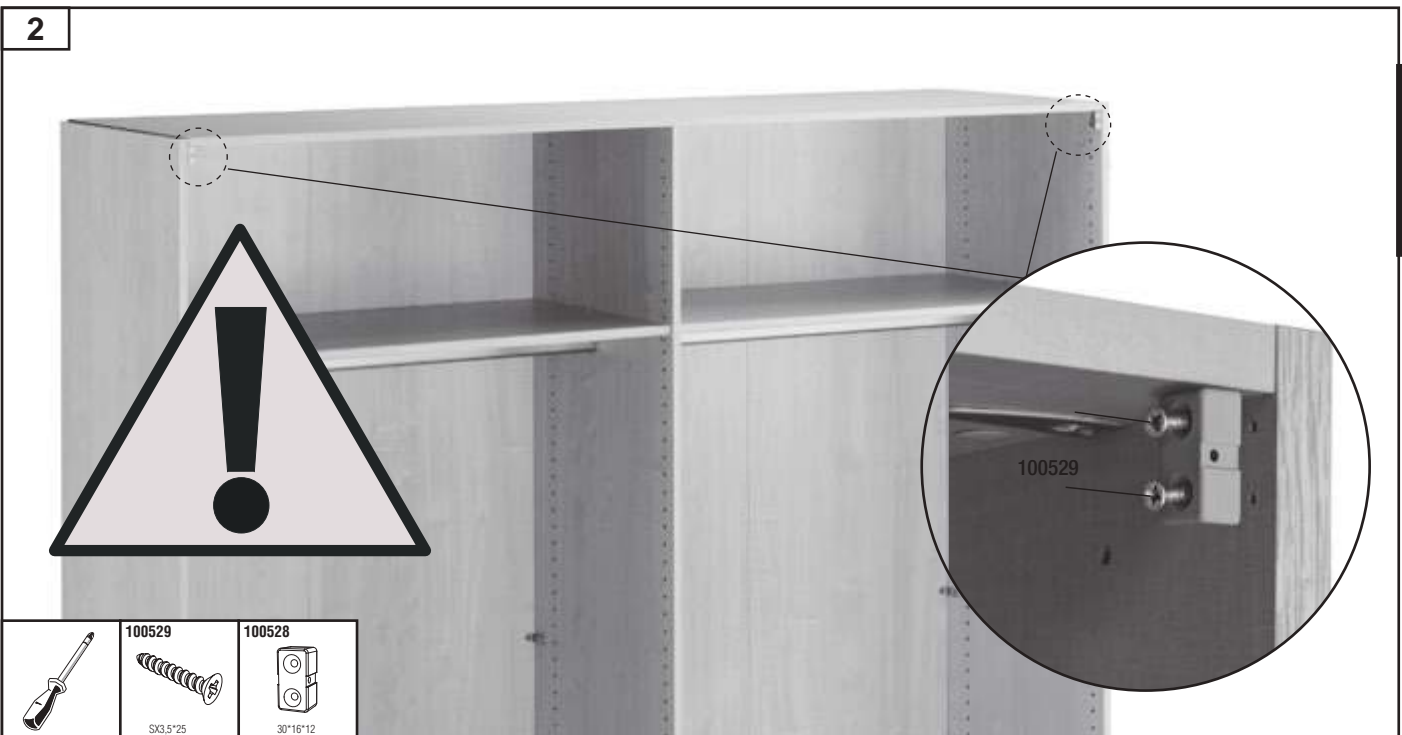

E

3

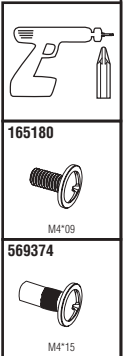
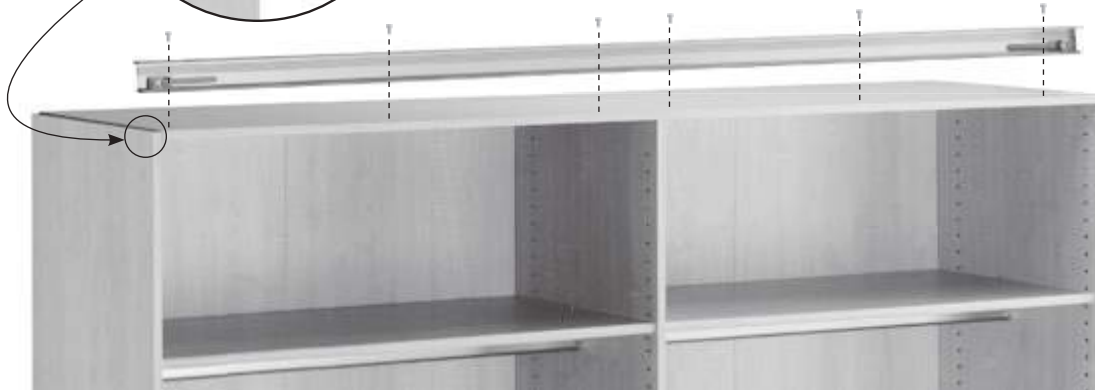
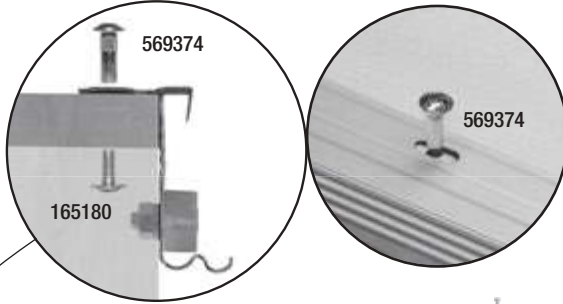

4

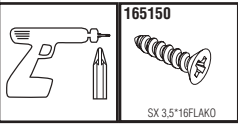
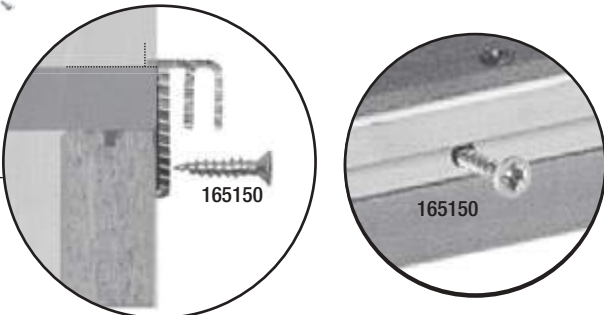
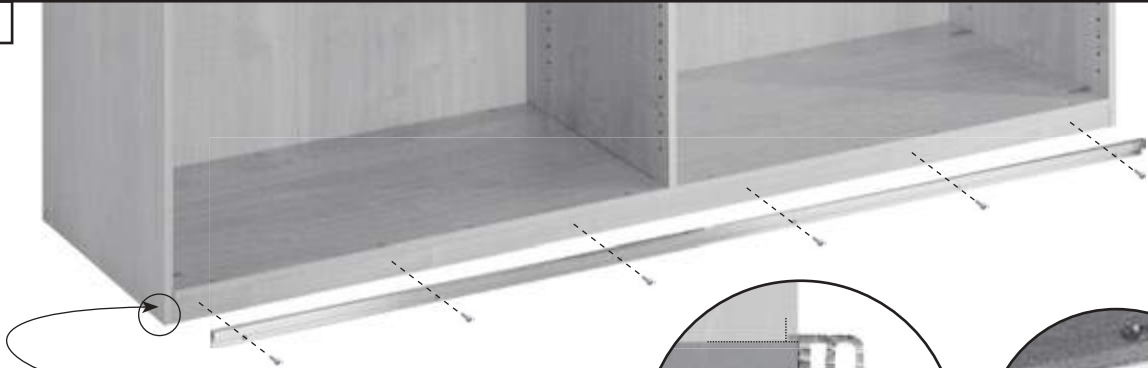

5

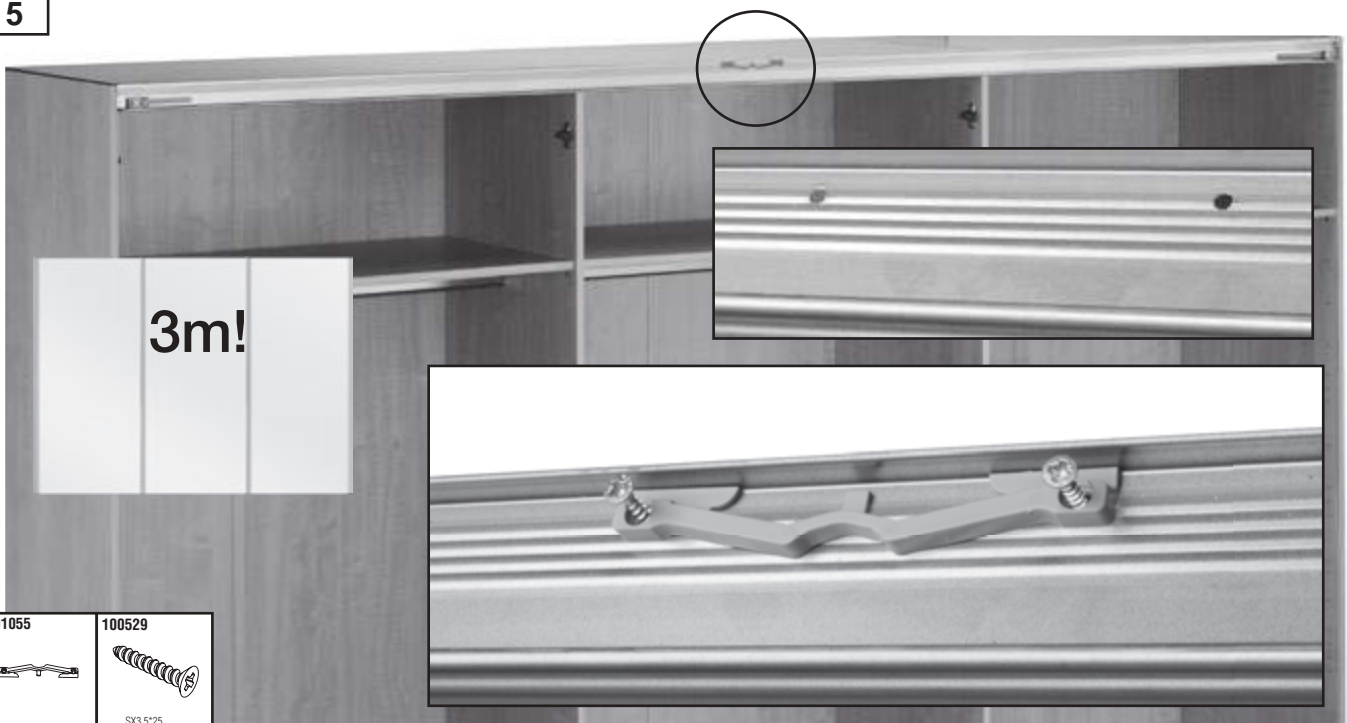

3m!

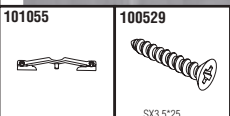

E

6

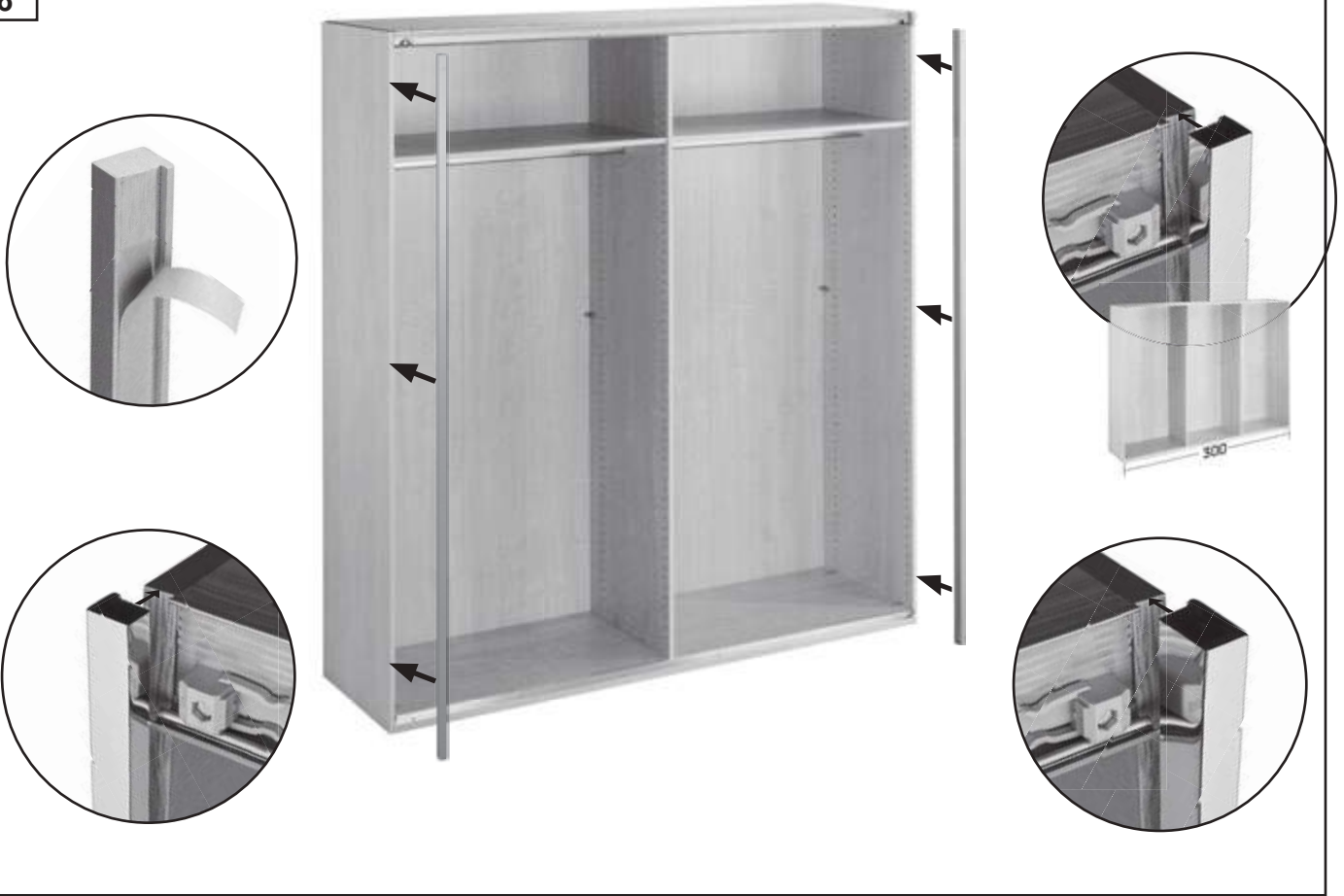

E

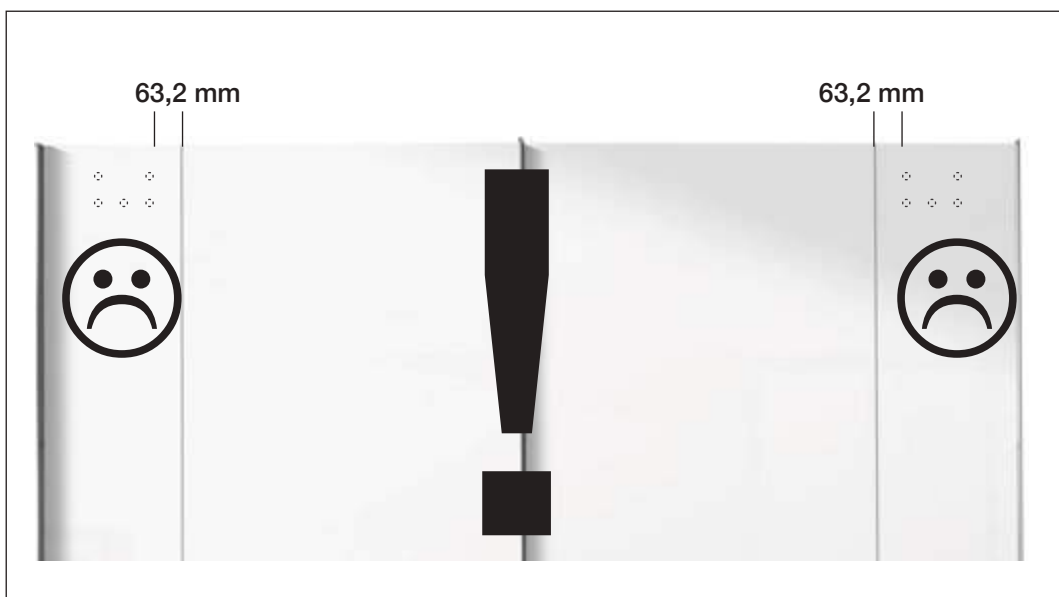
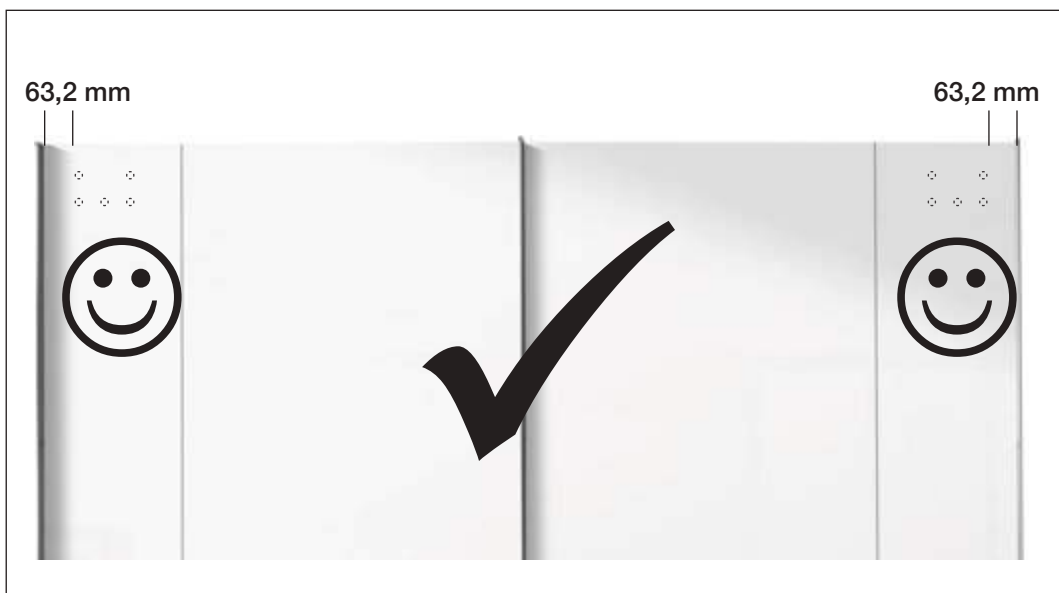
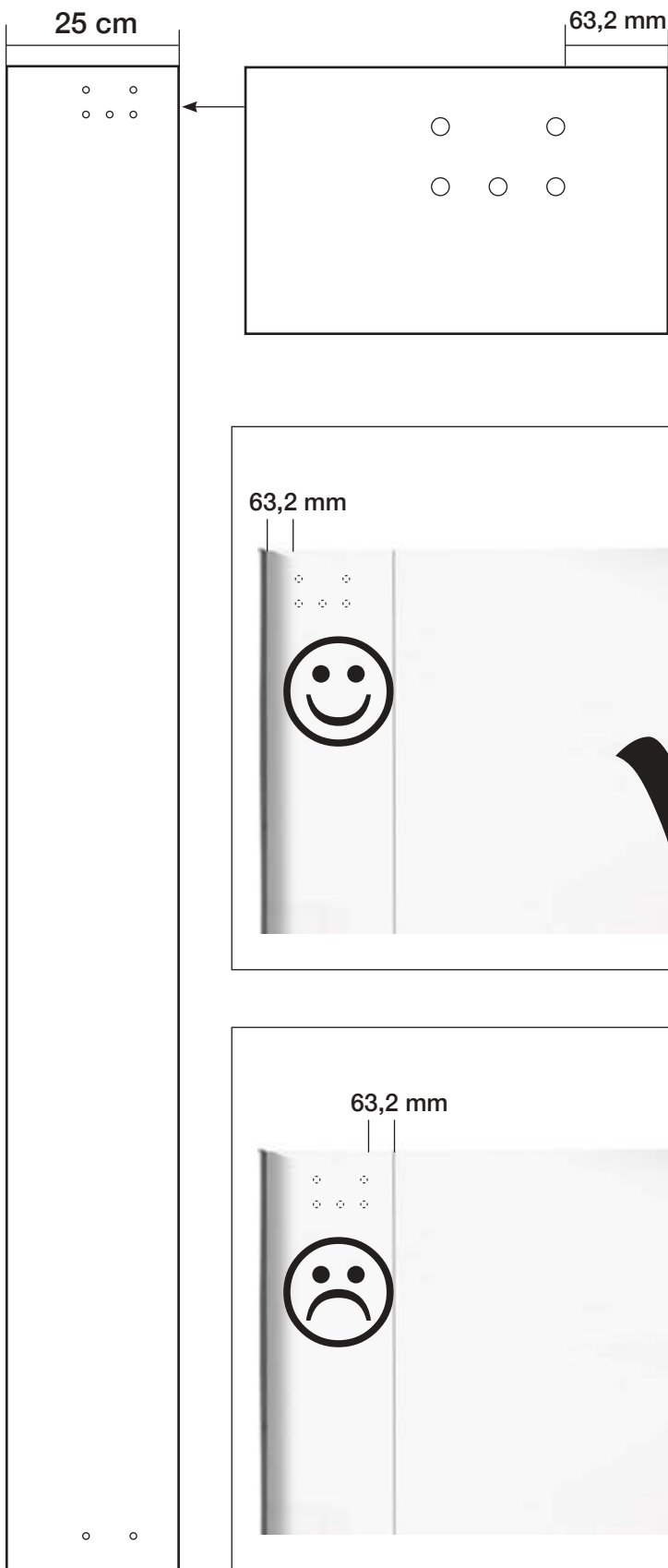

E

7

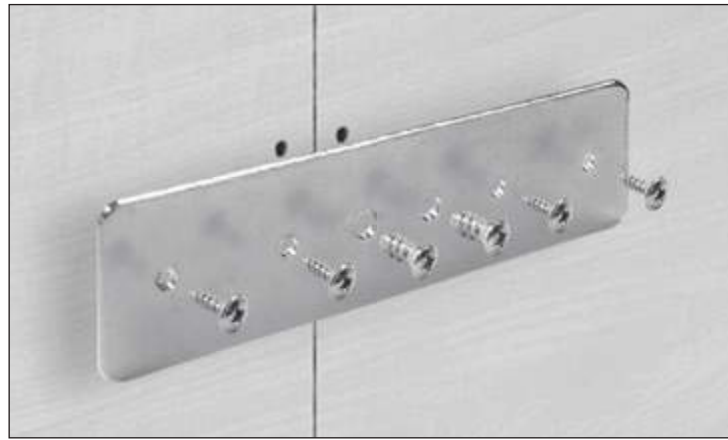
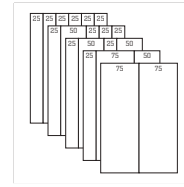
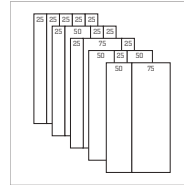
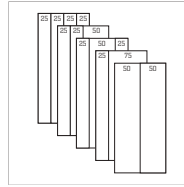
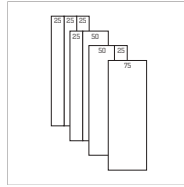

100788



100789



100918

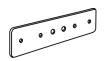

8



165200

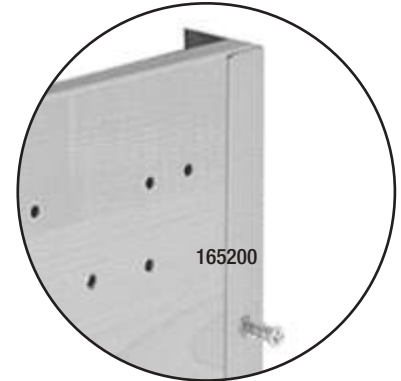
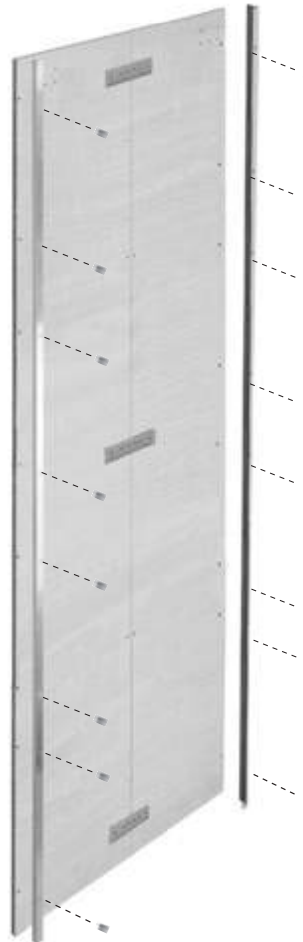

165200

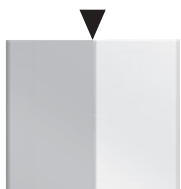

165200



6.3*13

E

9

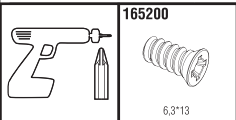
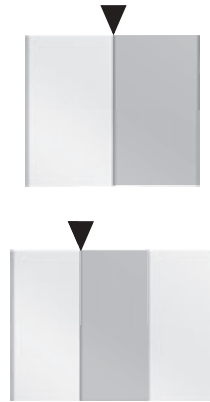
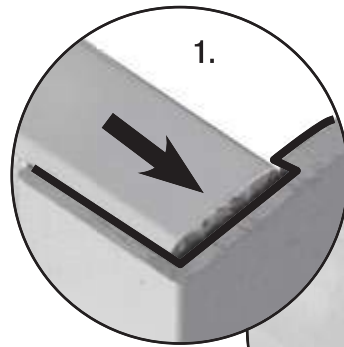
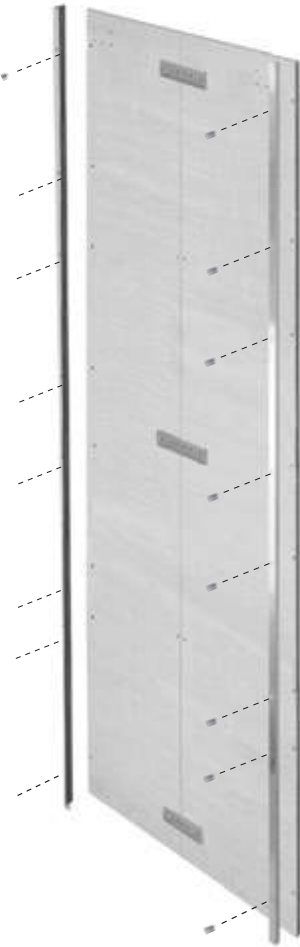
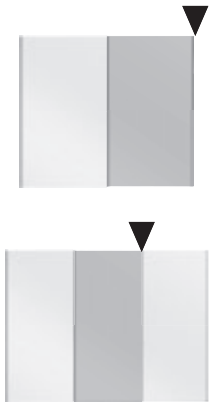
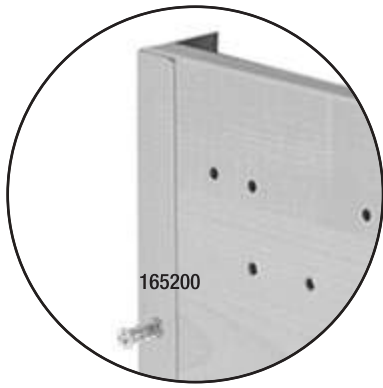

10

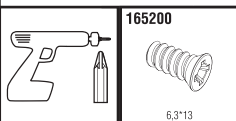
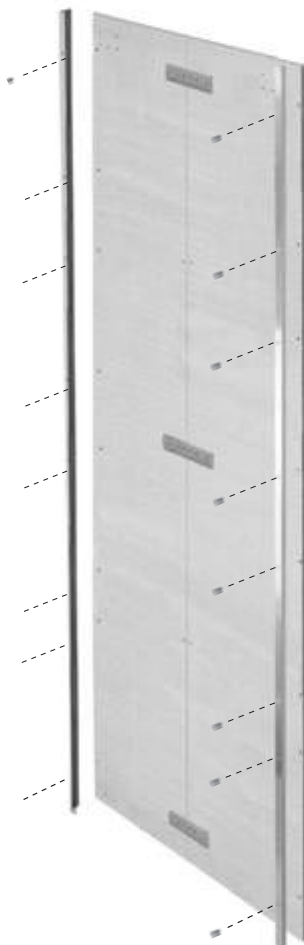

E

11

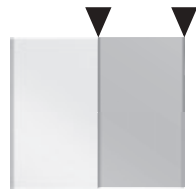
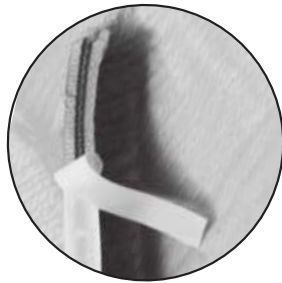

100534



11MM

12

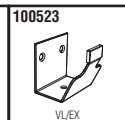
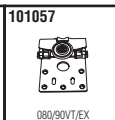
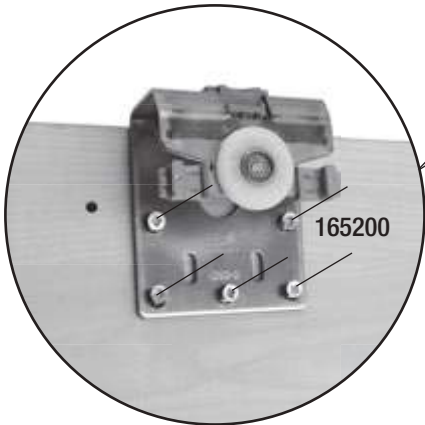

E

13

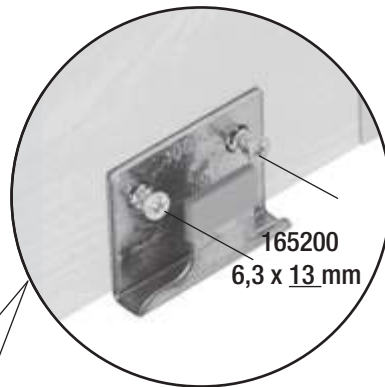
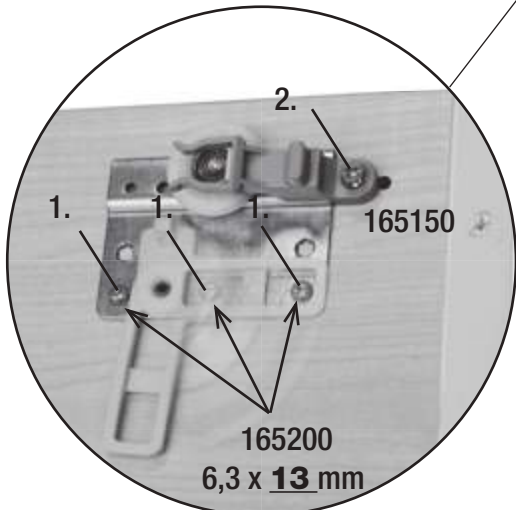
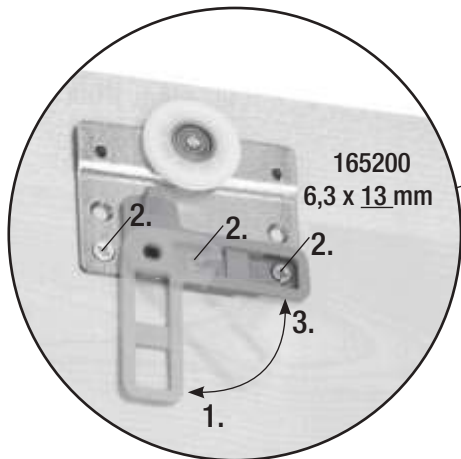

	100522 HL/EX	165150 SX 3,5*16FLAKO
101059 080/S9HT-AN-LI	100520 080/S9HT/EX	165200 6,3*13



14

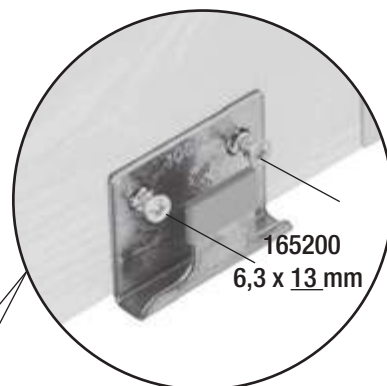
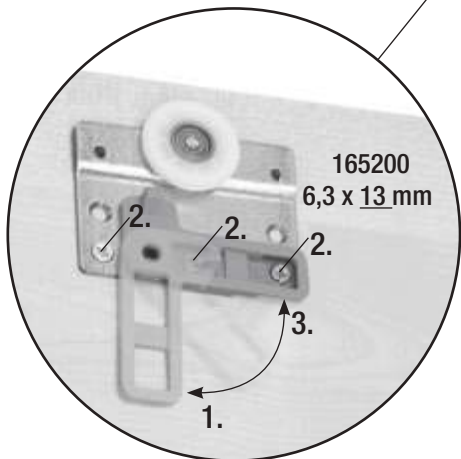
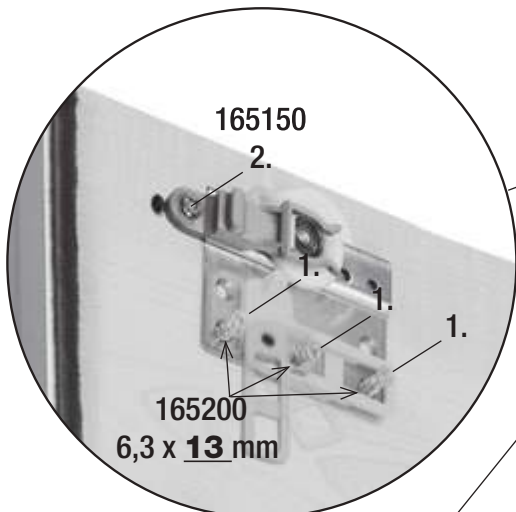

	100522 HL/EX	165150 SX 3,5*16FLAKO
101058 080/S9HT-AN-RE	100520 080/S9HT/EX	165200 6,3*13



E

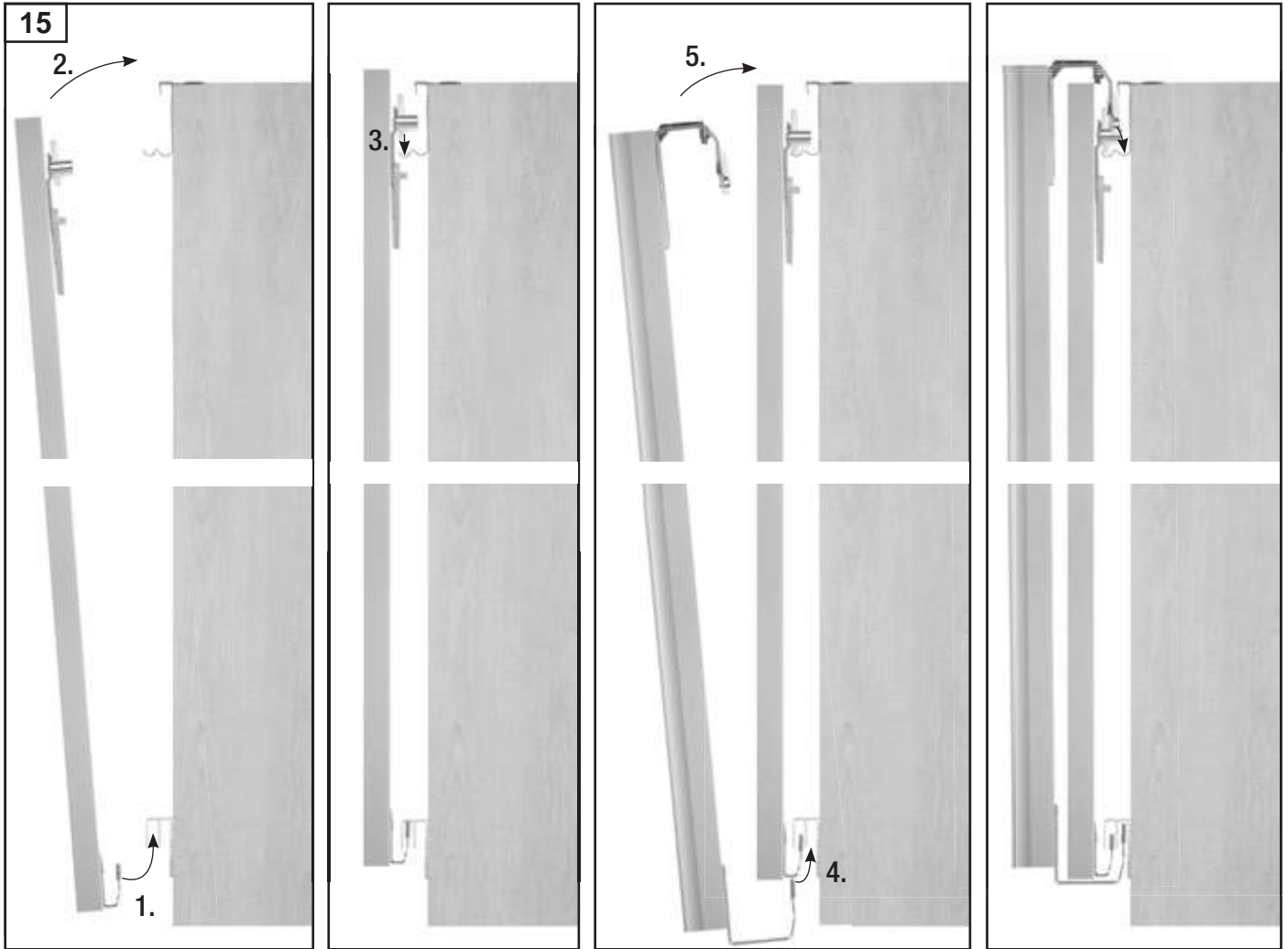

16

ACHTUNG!
 Aus Sicherheitsgründen muss das Möbelteil an der Wand befestigt werden. Beiliegendes Befestigungsmaterial eignet sich nur für Massivwände. Für andere Wände müssen Spezialdübel verwendet werden.

LET OP!
 Uit veiligheidsoverwegingen moet het meubeldeel aan de wand bevestigd worden. Bijgevoegt bevestigingsmateriaal is alleen bruikbaar voor massieve wanden. Voor andere wanden moeten speciale schroeven gebruikt worden.

ATTENTION!
 Pour des raisons de sécurité le meuble doit être fixé au mur. Le matériel ci-joint est approprié pour des murs épais. Pour d'autres murs utiliser des chevilles spéciales.





ATTENTION!
 For safety reasons please fix the unit to the walls. Enclosed fittings for stoned wall only. For other walls please use other pegs.

OBS!
 Af sikkerhedsmæssige årsager skal møblet fastgøres i væggen. Det vedlagte fastgørelsesmateriale er kun egnet til massive vægge. Til andre vægge skal der bruges special-dyvel.

UPOZORENJE!
 Iz sigurnosnih razloga ovaj dio namještaja mora biti pričvršćen za zid. Priloženi materijal za pričvršćivanje odgovara samo za masivne zidove. Za ostale zidove moraju biti primjenjeni specijalni tiplovi.

POZOR!
 Iz varnostnih razlogov je potrebno dele pohištva pritrditi na steno. Priloženi material za pritrditev je primeren samo za masivne stene. Za druge vrste sten je potrebno uporabiti posebne zatiče.

FIGYELEM!
 Biztonsági okokból a szekrényt a falhoz kell rögzíteni. A mellékelt rögzítőelemek csak masszív falak esetében alkalmazhatóak. Más fajta falak esetében speciális dübelcsapok alkalmazandók.

100501  8MM	100502  SX 5,0*45 FLAKO	100503  1.80.034	100507  SX 5,0*15
---	---	--	---



Aus Sicherheitsgründen Aushängesicherungen unbedingt montieren!

Uit veiligheidsoverwegingen is het noodzakelijk de ophangbevestigingen te monteren!

Pour des raisons de sécurité veuillez monter le clip de sécurité an d'éviter que les portes ne se décrochent!

For security reason please use the restraining clip to ensure the door remaining in the guiding rail!

Dørsikringen skal af sikkerhedshensyn altid monteres!

Iz sigurnosnih razloga sigurnosne vodilice za klizna vrata plakara moraju bezuvjetno biti namontirana!

Iz varnostnih razlogov je nujno namestiti zavarovanje za izobešanje!

Biztonsági okokból a kicsúszásgátlót mindenképpen szerelje fel!

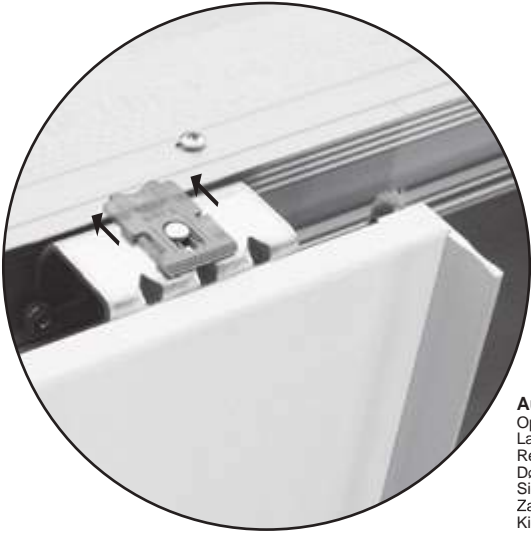

Aushängesicherung
Ophangbeveiliging
La sécurité
Restraining clip
Dørsikring
Sigurnosne vodilice
Zavarovanje za izobešanje
Kicsúszásgátló

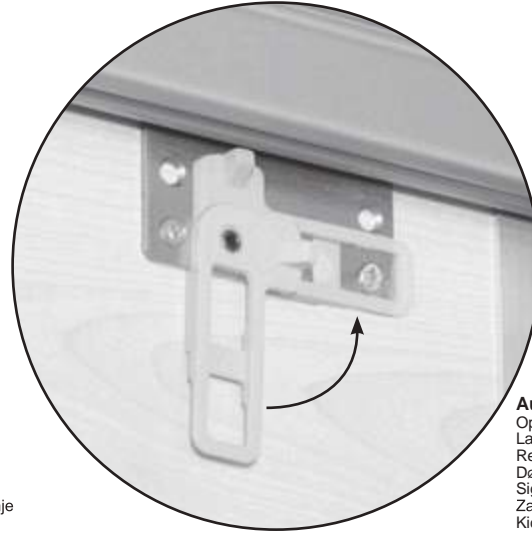

Aushängesicherung
Ophangbeveiliging
La sécurité
Restraining clip
Dørsikring
Sigurnosne vodilice
Zavarovanje za izobešanje
Kicsúszásgátló



Servicekarte

Servicekaart
 Carte de service
 Service card
 Servicekort
 Servisna karta
 Servisna kartica
 Szervíz kártya

100935_02_2015
 Express Möbel GmbH & Co. KG

Konrad-Nolte-Str. 16
 D-76726 Germersheim
 Tel.: 0049-7274-709-0
 Fax: 0049-7274-709-100
 Mail: support@express-moebel.de

Modellname	Typ	Kaufvertragsnr./Lieferscheinnr.	Datum
Modelnaam Nom de modèle Name of model Modelnavn Naziv modela Ime modela Modell neve	Type Type Type Type Tip Tip Tipus	Koopcontract nr./vervoerdokument nr. No. contrat d'achat/no. bon de livraison Purchase contract no./delivery note no. Kontrakt-nr./følgeseddel-nr. Broj prodajnog ugovora/Broj otpavnice Številka kupoprodajne pogodbe/Številka dostavnice Vételi szerződés száma/Szállítólevél száma	Date Date Date Dato Datum Datum Dátum

Fehlerursache						
Oorzaak van het gebrek	Raison de la réclamation	Reason for complaint	Fejlársag	Uzrok greške	Vzrok napake	Hiba oka

Etwaige Ersatzteilbestellungen übernimmt das Möbelhaus für Sie.
 Bij een eventuele bestelling van reserve onderdelen, neemt onze winkel deze kosten voor haar rekening.
 La commande de pièces détachées est à faire auprès du magasin de meubles.
 Should you require replacement for any parts of this product, your retailer will be pleased to pass on the order for you.
 Eventuel reservedels-bestilling foretages af møbelforretningen.
 Bilo koju narudžbu rezervnih dijelova za Vas preuzima robna kuća.
 Morebitna naročila nadomestnih delov za Vas prevzame pohištvni salon.
 Esetleges alkatrészrendelést bútórúháza átvállalja.

100001	100002	100003	100005	100006	100016	100020	100021	101043	165150	165160	100035	517710	527690
	M6*25		16mm	SX 4,5*50 RW	11mm				SX 3,5*16FLAKO	6,3*12			15/42
101058	101059	165150	100520	101057	100522	100523	101055	101052	101053	101054	100528	100529	165200
080/59HT-AN-RE	080/59HT-AN-LI	SX 3,5*16FLAKO	080/59HT-EX	080/90T/EX	HL-EX	VL-EX					30*16*12	SX3,5*25	6,3*13
165180	569374	100501	100502	100503	100534	100788	100789	100918					
M4*09	M4*15	8MM	SX 5,0*45 FLAKO	1.80.034	11MM								

- D** Oberflächen Kunststoff-Dekor Holznachbildung. Pflegehinweis: Mit leicht feuchtem Tuch reinigen, sofort trocken nachwischen. Möbel nicht für Feuchträume geeignet (Bad, Küche etc.). Nässe auf Oberfläche unverzüglich wegwischen. Aufbauanleitung aufbewahren. Das Möbel muss entsprechend der Aufbauanleitung montiert werden. Bei fehlerhafter Montage kann es zu Gefahren kommen. Das beigefügte Wandbefestigungsmaterial ist nur für Massivwände geeignet. Prüfen Sie den Untergrund und wählen Sie geeignete Befestigungsmittel entsprechend der auftretenden Kräfte und Untergründe aus. Erkundigen Sie sich gegebenenfalls beim Fachhandel.
- USA GB** The unit must be put together according to the assembly instructions. Hazards may arise in case of incorrect assembly. The enclosed wall fixings are only suitable for solid walls. Test the base and select suitable fixings in accordance with the forces which accrue at the bases. Obtain information from the specialist trade if necessary.
- F** Le meuble doit être monté conformément à l'instruction de montage. En cas d'erreur de montage, des dangers peuvent se manifester. Les accessoires de fixation au mur ci-joints ne sont appropriés que pour les murs en dur. Vérifiez le support et choisissez les moyens de fixation adéquats correspondant à la puissance et aux bases dont vous disposez. Veuillez, le cas échéant, vous en remettre au commerce spécialisé.
- NL** Het meubel moet volgens de handleiding worden gemonteerd. Door verkeerde montage kunnen gevaren ontstaan. Het bijgevoegde wandbevestigingsmateriaal is alleen voor massieve wanden geschikt. Controleer de ondergrond en kies geschikte bevestigingsmiddelen die passen bij de optredende krachten en ondergronden. Informeer eventueel bij de vakhandel.
- E** El ensamblaje del mueble tiene que ser montado respetando estrictamente las respectivas instrucciones de montaje. Un montaje inadecuado podrá provocar la ocurrencia de situaciones peligrosas. El material de sujeción para la pared suministrado junto con el mueble sólo está indicado para aplicarse en paredes macizas. Antes de aplicarlos, verifique cuál es su tipo de pared y elija entonces el material de sujeción adecuado, tomando en consideración la relación carga / material de la pared. En caso que fuera necesario, le recomendamos que hable con un vendedor en cualquier comercio especializado.
- TR** Mobilyanın montaj talimatnamesine uygun olarak monte edilmesi gereklidir. Hatalı montaj halinde tehlikeli durumlar meydana gelebilir. Verilen duvara sabitleme malzemesi, sadece masif duvarlar için uygundur. Zemini kontrol ediniz ve mevcut güç ve zemine uygun sabitleme malzemesi seçiniz. Gereklî olması halinde uzman satıcılardan bilgi ediniz.
- CZ** Nábytek musí být smontován podle návodu k montáži. U chybné montáži může dojít k nebezpečím. Příložený upevňovací materiál se hodí jen pro masivní zdi. Zkontrolujte podklad a zvolte odpovídající upevňovací prostředky podle účinkujících sil a podkladů. Nechte si popřípadě poradit v odborné prodejně.
- SK** Nábytok musí byť zmontovaný podľa návodu. Pri chybnej montáži môžu vzniknúť nebezpečenstvá. Priložený upevňovací materiál sa hodí iba pre masívne steny. Skontrolujte podklad a zvolte zodpovedajúce upevňovacie prostriedky podľa účinkujúcich síl a podkladov. Nechajte si popri prípade poradiť v odbornej predajni.
- RO** Mobilă trebuie montată conform instrucțiunilor de montare. În cazul unui montaj greșit vor putea exista pericole. Materialul destinat pentru consolidarea peretelui este adecvat numai pentru pereții masivi. Verificați materialul de fond și alegeți un mijloc de fixare adecvat corespunzător forțelor ce apar și a materialului de fond. Dacă va fi cazul informați-vă la magazinul de specialitate.
- H** A bútor összeszerelését a szerelési útmutatónak megfelelően végezze. A hibás szerelés veszélyt okozhat. A mellékelt rögzítő anyagok a falra történő erősítésre, kizárólag masszív falakra való szerelésre alkalmasak. Ellenőrizze az alapot, és válasszanak a várható terhelésnek és az alap minőségének megfelelő rögzítő anyagokat. Adott esetben érdeklődjének szaküzletben.
- PL** Mebel powinien być montowany według instrukcji montażu. Nie właściwy montaż może skutkować zagrożeniami. Dołączone części do montowania służą tylko do montowania na ścianach masywnych. Należy sprawdzić wytrzymałość podłoża i wybrać odpowiednie elementy do przymocowania w zależności od powstających sił i w zależności od podłoża. Eventualnie należy zasięgnąć porady w sklepie specjalistycznym.
- RUS** Мебель должна собираться по соответственной инструкции по сборке мебели. Неправильная сборка мебели может привести к опасным ситуациям. Прилагаемый материал для крепления к стене пригоден только для массивных стен. Проверьте поверхность для установки и выберите подходящий крепительный материал в соответствии с действительной нагрузкой и поверхностью установки. В случае необходимости наведите справки в торговой фирме.
- P** O móvel tem de ser montado seguindo-se estritamente as instruções de montagem. Procedimentos incorrectos podem provocar a ocorrência de situações perigosas. O material de fixação para a parede, fornecido junto com o móvel, só está recomendado para aplicação em paredes maciças. Verifique qual é o seu tipo de parede e escolha o material de fixação adequado, considerando o esforço a suportar e o material da parede. Recomendamos que consulte uma loja da especialidade se tiver dúvidas quanto à forma de proceder.
- I** Il mobile deve essere montato, attenendosi alle istruzioni di montaggio. Un montaggio errato potrebbe esporvi a rischi di vario tipo. Il materiale di fissaggio per pareti accluse è adatto soltanto a pareti massicce. Controllare la consistenza della parete e poi scegliere il materiale di fissaggio adatto e capace di sostenere i pesi degli elementi. A riguardo si prega di richiedere ulteriori informazioni presso un punto vendita specializzato.
- SLO** Pohoštvo mora biti montirano v skladu z navodili za sestavo. Zaradi napačne montaže lahko pride do nevarnosti. Priloženi material za pritrditev na steno je primeren samo za masivne stene. Preverite podlago in izberite primerna sredstva za pritrditev v skladu z nastajajočimi silami in podlago. Po potrebi povprašajte v strokovni trgovini.
- S** Möbeln måste monteras i enlighet med monteringsanvisningen. Om möbelen monteras felaktigt kan fara uppstå. Bifogat väggupphängningsmaterial är endast avsett för massiva väggar. Kontrollera grunden och välj lämpligt fästmaterial med hänsyn till grunden och de krafter som uppkommer. Fråga om råd i fackhandeln.
- N** Møbelet må monteres i henhold til bruksanvisningen. Ved feil montering kann det oppstå farer. Vedlagte materiale til bruk ved veggbefestigelse er bare egnet for massive vegger. Man må sjekke underlaget og så velge egnet festemiddel i henhold til de krefter som kan forekomme og som passer til underlaget. Eventuelt bør man spørre fagforhandleren om råd.
- LV** Mēbeles montāžu jāveic atbilstoši uzbūves instrukcijai. Nepareiza montāža var izraisīt bīstamību. Pievienotie piestiprināšanas materiāli ir paredzēti tikai piestiprināšanai pie masīvām sienām. Pārbaudiet pamatu un izvēlieties piemērotus piestiprināšanas līdzekļus, kas atbilst esošajam spriegojumam un pamatiem. Vajadzības gadījumā konsultējieties ar specializētajiem tirdzniecības aģentiem.
- LT** Baldą montuokite pagal montavimo instrukciją. Neteisingai sumontavus gali iškilti pavojus. Atkreipkite dėmesį į tai, kad turite naudoti sienos savybėms atitinkančius ir pakankamo stiprumo varžtus bei kaiščius. Pakuotėje esančios detalės skirtos pritvirtinimui prie sienos, yra tinkamos tik kapitalinėms sienoms. Patikrinkite pagrindą ir parinkite pritvirtinimo priemonę, tinkamą susidariusiai apkrovai ir pagrindui. Reikalui esant pasitarkaukite specializuotoje parduotuvėje.
- HR** Namještaj mora biti montiran u skladu s uputama za montažu. Pogreške u montaži mogu dovesti do raznih opasnosti. Priloženi materijal za učvršćivanje na zid pogodan je samo za masivne zidove. Provjerite podlogu i odaberite pogodna sredstva za učvršćivanje koja su primjerena nastajućim silama i podlogama. Raspitajte se po potrebi u specijaliziranim trgovinama.
- FIN** Huonekalu on koottava rakennusohjeiden mukaisesti. Vääränlaisesta asennuksesta saattaa olla seurauksena vaaratilanteita. Mukana toimitettu seinäkiinnitysmateriaali soveltuu vain massiiviseinille. Tarkista alusta ja valitse esiintyvien voimien ja alustan rakenteen mukaiset kiinnitysvälineet. Kysy tarvittaessa neuvoa alan erikoisliikkeestä.
- EST** Mööblid tuleb vastavalt kasutusjuhendile kokku monteerida. Ebaõige montaaž võib kätkeada endas ohtusid. Kaasasolev seinale kinnitamise materjal sobib üksnes monoliitseintele. Kontrollige, milline on aluspind ja valige sobiv kinnitusmaterjal vastavalt rakenduvale jõule ja aluspinnale. Küsige vajadusel nõu volitatud edasimüüjalt.
- DK** Møbelstykket skal monteres i overensstemmelse med vejledningen. Hvis montage gennemføres fejlagtigt, kan der opstå faremomenter. Det medfølgende materiale til fastgørelse i væggen er kun egnet til massive vægge. Efterprøv undergrunden og anvend egnede midler til fastgørelsen, som er passende til de kræfter, der optræder til undergrunden. I givet fald bør De indhente råd og vejledning i en specialhandel.
- BIH** Namještaj mora biti montiran prema uputstvu za montažu. Pogrešna montaža može izazvati razne opasnosti. Priloženi materijal za pričvršćivanje na zid pogodan je samo za masivne zidove. Provjerite podlogu i izaberite pogodna sredstva za učvršćivanje koja odgovaraju nastajućim silama i podlogama. Ako je potrebno, raspitajte se u specijalizovanim prodavaonicama.
- SCG** Namештај мора бити монтиран сходно упутству за монтажу. Погрешна монтажа може изазвати разне опасности. Приложени материјал за учвршћивање на зид погодан је само за масивне зидове. Проверите подлогу и одаберите погодна средства за учвршћивање која одговарају настajuћим силама и датим подлогама. Распитajte се по потреби у специјализованим продавницама.
- BG** Монтажът на мебелите да се извършва съобразно инструкцията за монтаж. Неправилният монтаж може да крие рискове. Приложеният скрепителен материал е подходящ само за масивни стени. Проверете основата и изберете подходящи скрепителни елементи съобразно възникващото напрежение и основата. Ако е необходимо, се информирайте в специализираните магазини.